

ELATION[®]

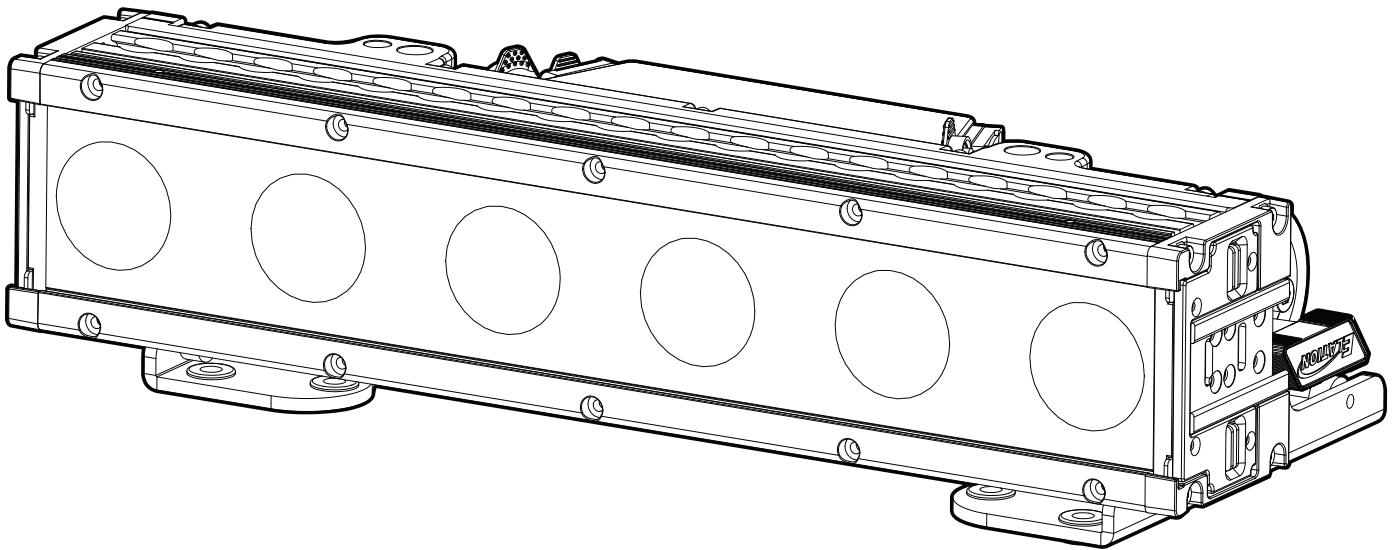

SIX+ BAR S User Manual

©2026 ELATION PROFESSIONAL all rights reserved. Information, specifications, diagrams, images, and instructions herein are subject to change without notice. ELATION PROFESSIONAL logo and identifying product names and numbers herein are trademarks of ELATION PROFESSIONAL. Copyright protection claimed includes all forms and matters of copyrightable materials and information now allowed by statutory or judicial law or hereinafter granted. Product names used in this document may be trademarks or registered trademarks of their respective companies and are hereby acknowledged. All non-ELATION brands and product names are trademarks or registered trademarks of their respective companies.

ELATION PROFESSIONAL and all affiliated companies hereby disclaim any and all liabilities for property, equipment, building, and electrical damages, injuries to any persons, and direct or indirect economic loss associated with the use or reliance of any information contained within this document, and/or as a result of the improper, unsafe, insufficient and negligent assembly, installation, rigging, and operation of this product.

Elation Professional USA | 6122 S. Eastern Ave. | Los Angeles, CA. 90040

323-582-3322 | www.elationlighting.com | info@elationlighting.com

Elation Professional B.V. | Junostraat 2 | 6468 EW Kerkrade, The Netherlands

+31 45 546 85 66 | www.elationlighting.eu | info@elationlighting.eu

Elation Professional Mexico | AV Santa Ana 30 | Parque Industrial Lerma, Lerma, Mexico 52000

+52 (728) 282-7070

DOCUMENT VERSION



Due to additional product features and/or enhancements, an updated version of this document may be available online. Please scan the QR Code with your mobile device or visit www.elationlighting.com for the latest revision/update of this manual, before installation and/or programming.

Date	Document Version	Software Version	DMX Channel Mode	Notes
09/23/24	1.0	1.01	1/3/6/9/13/16/16/22/22/34/46/82/36	Initial Release
10/14/24	1.1	N/C	No change	Corrected DMX Traits
03/07/25	1.2	N/C	No change	Updated Emulation DMX Traits, Specifications
04/17/25	1.3	N/C	No Change	Updated IP65 Rated, Installation Guidelines, Safety Guidelines, System Menu
09/22/25	1.4	N/C	No Change	Updated Installation Guidelines, Specifications, Ordering Information
12/04/25	1.5	N/C	No Change	Updated: General Info, IP65 Rated, Installation Guidelines, Specifications, Dimensional Drawings; Added Aria Setup and Guidelines
04/13/26	1.6	N/C	No Change	Update Specifications
06/18/26	1.7	N/C	No Change	Updated: General Info, Installation Guidelines, Specifications; Added Index

CONTENTS

General Information	4
IP65 Rated	5
Safety Guidelines	6
Overview	8
Torque Settings for Screws	9
IP Test Parameters	10
Installation Guidelines	11
Accessory Installation	19
Aria Setup and Guidelines	21
Remote Device Management (RDM)	24
System Menu/Software Updates	25
Dimmer Modes & Curves	28
DMX Traits	29
Emulation DMX Traits for SixBar 500	35
Pixel Grouping & Flip Diagram	38
Color Temperature	39
Virtual Colors	40
Error Codes	41
Maintenance Guidelines	42
Specifications	43
Dimensional Drawings	44
Ordering Information Error Codes	46
Index	47

GENERAL INFORMATION

INTRODUCTION

Please read and understand the instructions in this manual carefully and thoroughly before attempting to operate this device. These instructions contain important safety and use information. **This device is intended for professional use only.**

UNPACKING

Every device has been thoroughly tested and has been shipped in perfect operating condition. Carefully check the shipping carton for damage that may have occurred during shipping. If the carton is damaged, carefully inspect the device for damage, and be sure all accessories necessary to install and operate the device have arrived intact. In the event damage has been found or parts are missing, please contact our customer support team for further instructions. Please do not return this device to your dealer without first contacting customer support. Please do not discard the shipping carton in the trash. Please recycle whenever possible.

BOX CONTENTS

Safety Cable
IP65 Locking Power Cable
Frost Filter
Glare Shield
Fixture Interconnect Splice

CUSTOMER SUPPORT

Contact ELATION Service for any product related service and support needs. Also visit forums.elationlighting.com with questions, comments or suggestions.

ELATION SERVICE USA - Monday - Friday 8:00am to 4:30pm PST

323-582-3322 | support@elationlighting.com

ELATION SERVICE EUROPE - Monday - Friday 08:30 to 17:00 CET

+31 45 546 85 63 | support@elationlighting.eu

REPLACEMENT PARTS please visit parts.elationlighting.com

LIMITED WARRANTY

For up-to-date warranty information regarding your device, please visit Elation's warranty information page online or scan the QR codes below.



USA: <https://www.elationlighting.com/warranty-information>



EU: https://www.elationlighting.eu/terms_and_conditions

THERE ARE NO USER SERVICEABLE PARTS INSIDE THIS UNIT. DO NOT ATTEMPT ANY REPAIRS YOURSELF, AS DOING SO WILL VOID YOUR MANUFACTURER'S WARRANTY. DAMAGES RESULTING FROM MODIFICATIONS TO THIS FIXTURE AND/OR THE DISREGARD OF SAFETY INSTRUCTIONS AND GUIDELINES IN THIS MANUAL VOID THE MANUFACTURER'S WARRANTY AND ARE NOT SUBJECT TO ANY WARRANTY CLAIMS AND/OR REPAIRS.

IP65 RATED

The International Protection (IP) rating system is commonly expressed as “IP” (Ingress Protection) followed by two numbers (i.e. IP65), where the numbers define the degree of protection. The first digit (Foreign Bodies Protection) indicates the extent of protection against particles entering the fixture, and the second digit (Water Protection) indicates the extent of protection against water entering the fixture. An **IP65** rated lighting fixture is designed and tested to protect against the ingress of dust (**6**), and low-pressure water jets from any direction (**5**).

THIS FIXTURE IS INTENDED FOR TEMPORARY OUTDOOR USE ONLY!

Maritime/Seaside Environment Installations: A maritime/seaside environment is adjacent to the sea and caustic to electronics through exposure to atomized salt water and humidity, whereas a coastal environment extends 5 miles inland.

Maritime installations require additional preparation, and additional service intervals may be needed given the maritime use. In general, IP ratings presuppose freshwater conditions VS maritime conditions, which are typically more “caustic” to IP fixtures (both internally and externally). A duty-cycle may also be needed when units are not in use. During times of high humidity and colder temperatures, condensation may occur internally so the fixture may require a duty-cycle to bring it up to running temperature, allowing any accumulation of moisture to be expelled via the vent valve. Recommendations can change based on installation environmental circumstances.

NOTE: NOT ALL FEATURES LISTED ARE AVAILABLE ON ALL FIXTURES; THE FOLLOWING INSTRUCTIONS MAY NOT APPLY. CONTACT SUPPORT FOR ADDITIONAL DETAILS.

Exterior Maintenance: Inspect the exterior every 30-days. The unit must be powered off/disconnected. The chassis should be inspected for any signs of contaminants. Inspect optics to determine if the lens is obstructed, then clean optics and chassis accordingly. Based on initial finding, schedule maintenance accordingly, keeping in mind that exterior maintenance will be required. Even if the luminaires are NOT in use, maintenance will still be needed given its location (exterior use). The use of a durable type of wax on the chassis is recommended since it will help prevent contaminant build up. Inspect both power and data lines for any signs of contaminants or corrosion. Periodically reapplying di-electric grease, especially in coastal environments. If any signs of corrosion/contaminants are present, clean thoroughly, and/or replace connectors, then reapply di-electric grease. Typically, this should be done annually, or any time an opportunity presents itself. As a preventive measure, annual replacement of both vent valves is recommended. The vent valve membrane can become contaminated and/or clogged causing improper venting of humidity within the luminaire. Inspect all mounting hardware as a precaution.

Interior Maintenance: Inspect the interior every 30-days. The unit must be powered off/disconnected.

- Inspect zoom/focus mechanism, clean optics, lubricate linear bearings (Krytox oil) as needed, inspect belts for wear
- Inspect all rotating effect wheels, manually rotate them, note any resistance
- Inspect all remaining rotating belts for any wear
- Inspect all fans, clean as needed, check rotation, check connections
- Inspect CMY module, manually move flags and check for signs of resistance, and if needed, clean guide rods first, then reapply a thin layer of grease (moly lube)
- Clean interior with low-volume compressed air, then clean optics prior to reassembly of head covers

Although the base has limited moving parts, the pan belt should also be inspected for wear. Remember to always perform an IP test anytime a cover is removed.

There is no specific time frame regarding the routine replacement of parts such as belts/stepper motors, PCBs, or LEDs. These items should only be replaced on an as needed bases, except for cooling fans, which should be replaced once the luminaries reach 10,000-hours. This is a prophylactic measure intended to keep the unit running as cool as possible, insuring proper function of all internal components. A complete service breakdown is available, please contact service@elationlighting.com for any needed parts or manuals.

SAFETY GUIDELINES

This fixture is a sophisticated piece of electronic equipment. To guarantee smooth operation, it is important to follow all instructions and guidelines in this manual. Elation Professional is not responsible for injury and/or damages resulting from the misuse of this fixture due to the disregard of the information printed in this manual. Only qualified and/or certified personnel should perform installation of this fixture and only the original rigging parts included with this fixture should be used for installation. Any modifications to the fixture and/or the included mounting hardware will void the original manufacturer's warranty and increase the risk of damage and/or personal injury.



PROTECTION CLASS 1 - FIXTURE MUST BE PROPERLY GROUNDED.



THERE ARE NO USER SERVICEABLE PARTS INSIDE THIS UNIT. DO NOT ATTEMPT ANY REPAIRS YOURSELF. DOING SO WILL VOID YOUR MANUFACTURER'S WARRANTY. DAMAGES RESULTING FROM MODIFICATIONS TO THIS DEVICE AND/OR THE DISREGARD OF SAFETY INSTRUCTIONS AND GUIDELINES IN THIS MANUAL VOID THE MANUFACTURER'S WARRANTY AND ARE NOT SUBJECT TO ANY WARRANTY CLAIMS AND/OR REPAIRS.



**DO NOT PLUG THIS UNIT INTO A DIMMER PACK
DO NOT REMOVE THE COVER UNDER ANY CONDITIONS
NEVER OPERATE THIS UNIT WITH THE CASING REMOVED
UNPLUG FROM POWER DURING LONG PERIODS OF NON-USE
DISCONNECT POWER BEFORE PERFORMING MAINTENANCE**

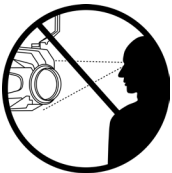

**NEVER LOOK DIRECTLY INTO THE LIGHT SOURCE!
RETINA INJURY RISK - MAY INDUCE BLINDNESS!
SENSITIVE PERSONS MAY SUFFER AN EPILEPTIC SHOCK!**



**FIXTURE SHOULD BE PLACED A MINIMUM OF 1.0 FOOT (0.3 METERS) FROM ANY NEARLY OBJECTS OR SURFACES.
FIXTURE SHOULD BE PLACED A MINIMUM OF 1.6 FEET (0.5 METERS) FROM ANY FLAMMABLE MATERIALS.
MAXIMUM AMBIENT OPERATING TEMPERATURE IS 113°F (45°C)**

SAFETY GUIDELINES

! CAUTION

HIGH INTENSITY ULTRAVIOLET LIGHT



AVOID DIRECT EYE & SKIN EXPOSURE.
WEAR PROPER EYE & SKIN PROTECTION.
SEE MANUAL FOR SAFETY INSTRUCTIONS.

RISK GROUP 3 - RISK OF EXPOSURE TO ULTRAVIOLET UV RADIATION! FIXTURE EMITS HIGH INTENSITY WAVELENGTH OF ULTRAVIOLET UV LIGHT FROM THE UV COLOR FILTER. WEAR PROPER EYE AND SKIN PROTECTION. AVOID PROLONGED PERIODS OF EXPOSURE TO UV COLOR FILTER. AVOID WEARING WHITE COLOR CLOTHING AND/OR USING UV PAINTS ON SKIN. AVOID DIRECT EYE AND/OR SKIN EXPOSURE AT DISTANCES LESS THAN 10 feet (3m). DO NOT OPERATE FIXTURE WITH DAMAGED/MISSING EXTERNAL COVERS. DO NOT LOOK DIRECTLY INTO THE UV LIGHT AND/OR VIEW UV LIGHT DIRECTLY WITH OPTICAL INSTRUMENTS THAT MAY CONCENTRATE THE LIGHT/RADIATION OUTPUT. INDIVIDUALS SUFFERING FROM A RANGE OF EYE CONDITIONS, SUNLIGHT EXPOSURE DISORDERS, OR INDIVIDUALS USING PHOTSENSITIVE MEDICATION, MAY RECEIVE DISCOMFORT IF EXPOSED TO THE ULTRAVIOLET UV LIGHT EMITTED FROM THE UV LED.

- **DO NOT TOUCH** the fixture housing during operation. Turn OFF the power and allow approximately 15 minutes for the fixture to cool down before serving.
- **DO NOT** shake fixture, avoid brute force when installing and/or operating fixture.
- **DO NOT** operate fixture if the power cord is frayed, crimped damaged and/or if any of the power cord connectors are damaged and do not insert into the fixture securely with ease.
- **NEVER** force a power cord connector into the fixture. If the power cord or any of its connectors are damaged, replace it immediately with a new one of similar power rating.
- Allow approx.6"(15cm) between fixture and other devices or a wall for proper cooling.
- Always disconnect fixture from main power source before performing any type of service and/or cleaning procedure. Only handle the power cord by the plug end, never pull out the plug by tugging the wire portion of the cord.
- During the initial operation of this fixture, a light smoke or smell may emit from the interior of the fixture. This is a normal process and is caused by excess paint in the interior of the casing burning off from the heat associated with the lamp and will decrease gradually over time.
- Consistent operational breaks will ensure the fixture will function properly for many years.
- **ONLY** use the original packaging and materials to transport the fixture in for service.

OVERVIEW

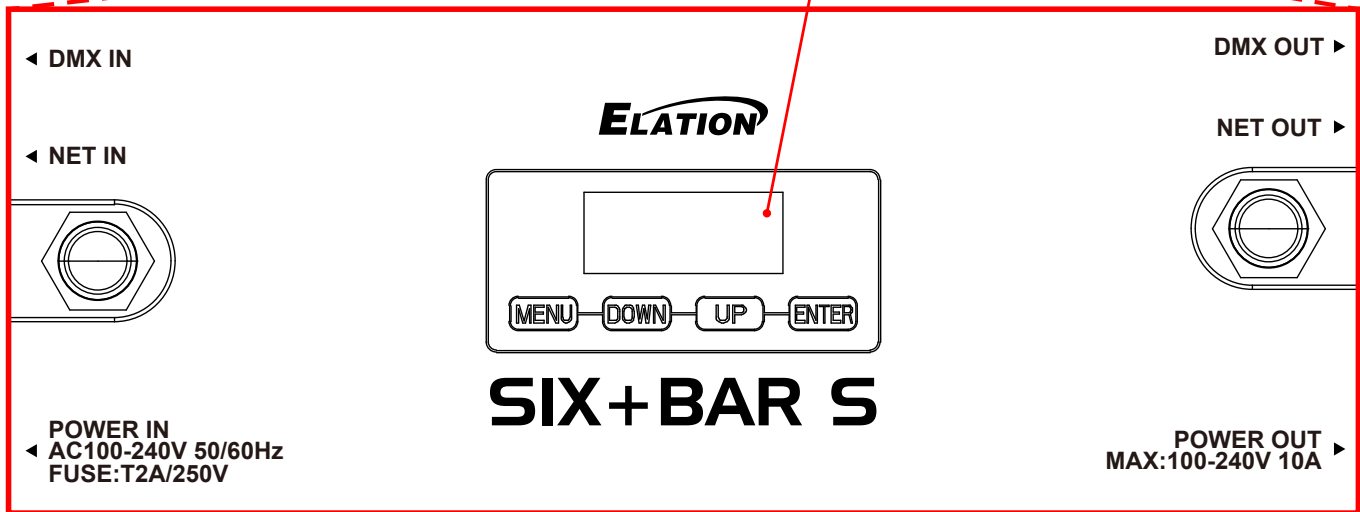
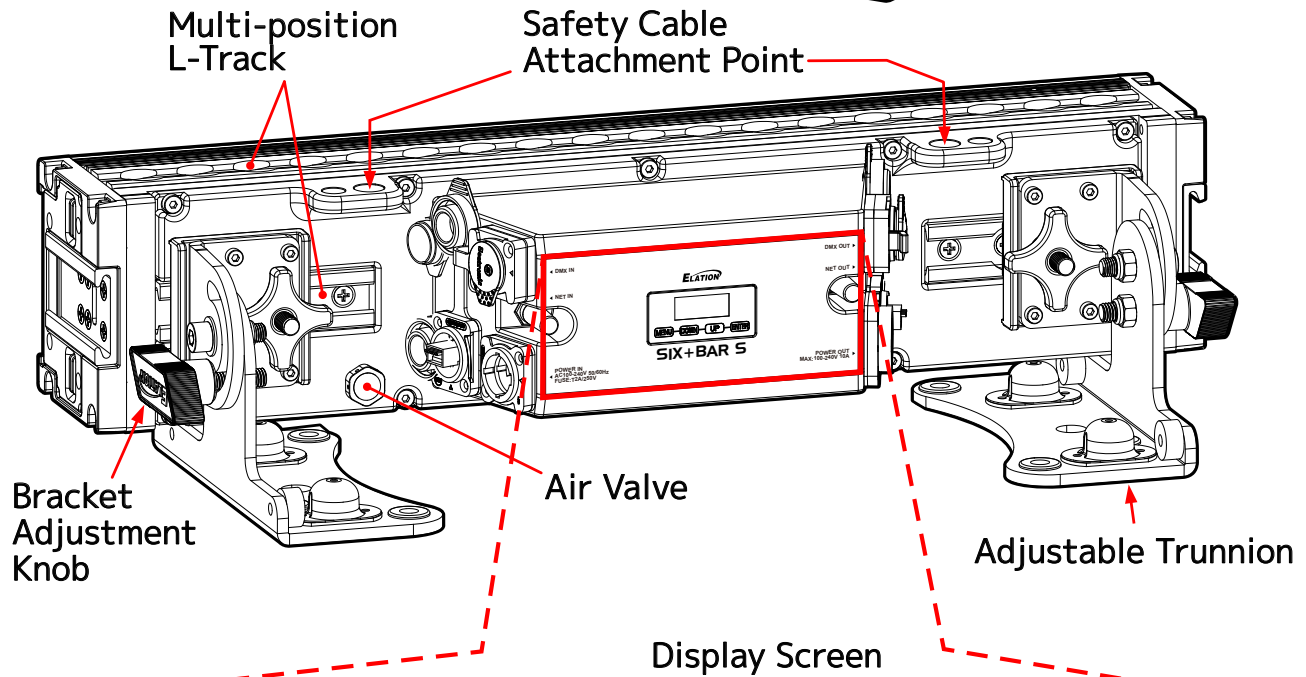
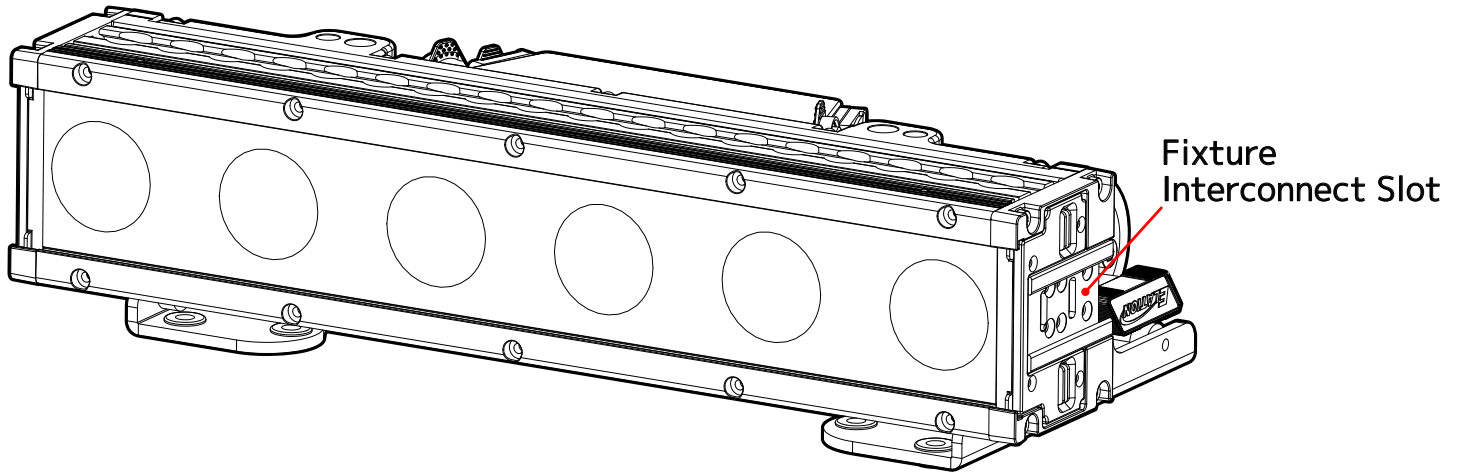

TORQUE SETTINGS FOR SCREWS

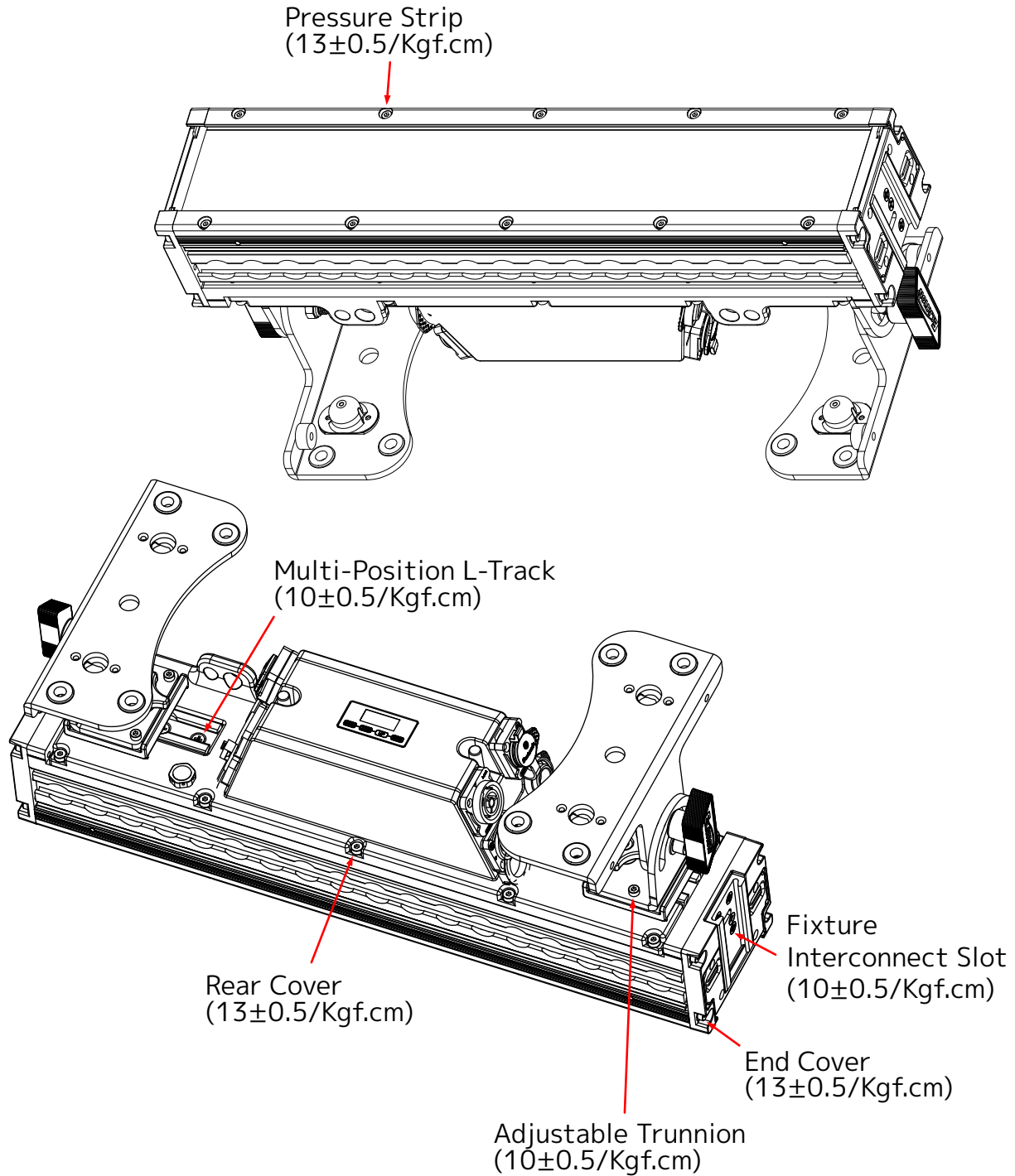

**CAUTION! DO NOT OVER TORQUE SCREWS AS THIS CAN CAUSE LEAKAGE ISSUES!
TO CONFIRM THE IP65 INTEGRITY, TEST FIXTURE USING THE ELATION IP TESTER. CONTACT
ELATION SERVICE FOR MORE DETAILS.**

IP TEST PARAMETERS

Following any repair or maintenance procedure that requires disassembly of the fixture, use Elation's IP Tester to confirm the IP integrity of the fixture. The air valve is located on the back panel next to the display screen, as shown in the diagram below. Please contact Elation Service for information regarding the Elation IP Tester, or visit the product information page online at: <https://www.elationlighting.com/ip-tester>



CAUTION! THE USE OF PROTECTIVE GLOVES AND SAFETY GOGGLES IS STRONGLY RECOMMENDED WHILE PERFORMING THE IP PRESSURE TEST! AVOID PLACING YOUR FACE, EYES, HANDS, ETC IN PROXIMITY TO THE LENS OF THE FIXTURE WHILE PERFORMING THE TEST!

DE-HUMIDIFICATION: IP65 fixtures operating in high-humidity environments may experience residual fogging or condensation. Such fogging will not affect the fixture, and can be removed using the following procedure: position the unit with the air valve pointing upwards, then open the air valve and run the unit for 1-2 hours after reaching operating temperature. Then, while the fixture is still hot, re-install the air valve and allow the unit to cool down. Please note: this procedure should be performed in a dry, climate-controlled environment. Avoid additional fogging by drying the fixture completely before placing into a road case.

Elation Product	Minimum Value		Maximum Value		Inflation Time	Balance Time	Inspection Time	Leakage
	Kpa	Psi	Kpa	Psi	S	S	S	Pa
Elation SIX+ BAR S	20	3	23	3	30	15	15	>100

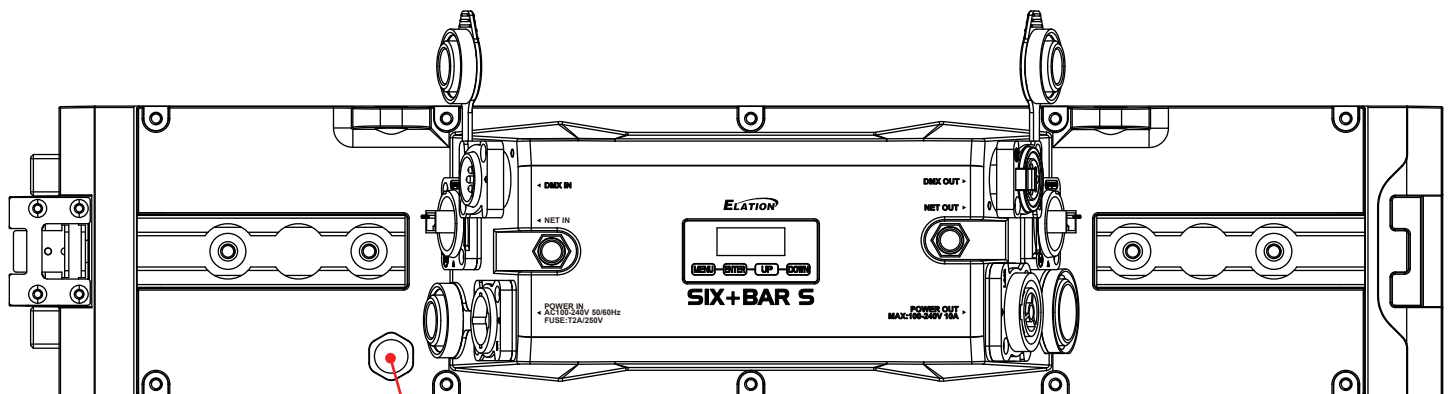

Air Valve



INSTALLATION GUIDELINES



FLAMMABLE MATERIAL WARNING

Keep fixture minimum 5.0 feet (1.5m) away from flammable materials and/or pyrotechnics.



ELECTRICAL CONNECTIONS

A qualified electrician should be used for all electrical connections and/or installations.



MINIMUM DISTANCE TO OBJECTS/SURFACES IS 1 FOOT (0.3 METERS)



MINIMUM DISTANCE OF FLAMMABLE MATERIALS FROM THE SURFACE IS 1.6 FEET (0.5 METER)



MAXIMUM AMBIENT TEMPERATURE 113° F (45°C)



DO NOT INSTALL THE FIXTURE IF YOU ARE NOT QUALIFIED TO DO SO!

Fixture **MUST** be installed following all local, national, and country commercial electrical and construction codes and regulations.

Before rigging/mounting a single fixture or multiple fixtures to any metal truss/structure or placing the fixture(s) on any surface, a professional equipment installer **MUST** be consulted to determine if the metal truss/structure or surface is properly certified to safely hold the combined weight of the fixture(s), clamps, cables, and accessories.

Fixture(s) should be installed in areas outside walking paths, seating areas, or away from areas where unauthorized personnel might reach the fixture by hand.

NEVER stand directly below the fixture(s) when rigging, removing, or servicing.

Overhead fixture installation must always be secured with a secondary safety attachment, such as an appropriately rated safety cable.

Allow approximately 15 minutes for the fixture to cool down before servicing.

ATTENTION: WHEN INSTALLING MULTIPLE FIXTURES IN ANY CONFIGURATION—WHETHER VERTICAL, HORIZONTAL, OR CUSTOM-SHAPED—IT IS ESSENTIAL TO SECURE THEM ADEQUATELY. THEY MUST BE FIRMLY ANCHORED TO WITHSTAND LATERAL FORCES, INCLUDING WIND OR JARRING IMPACTS FROM PEOPLE OR OBJECTS, TO PREVENT ANY DISPLACEMENT.

INSTALLATION GUIDELINES

CLAMP INSTALLATION

This device features a mounting clamp attachment point built into the Adjustable Trunnion, as well as a safety cable attachment point located on the bottom of the fixture.

OMEGA BRACKETS WITH CLAMP INSTALLATION

Insert the Omega Brackets into the matching holes in the Adjustable Trunnion. Secure the Omega Brackets to the fixture by turning each quick-lock fastener ¼ turn clockwise; making sure the fastener is completely locked.

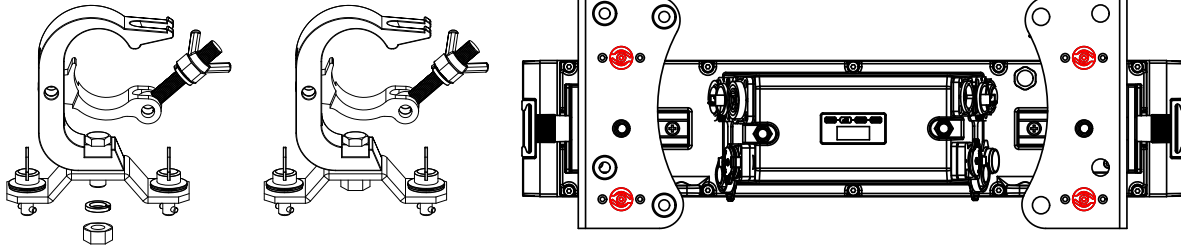

SAFETY CABLE

ALWAYS ATTACH AN APPROPRIATELY RATED SAFETY CABLE WHENEVER INSTALLING THIS FIXTURE IN A SUSPENDED ENVIRONMENT TO ENSURE THE FIXTURE WILL NOT FALL IF THE CLAMP FAILS.

IF THE FIXTURES ARE PART OF A LARGER ARRAY, ATTACH A SAFETY CABLE TO THE SAFETY CABLE ATTACHMENT POINT ON THE BACK OF EACH FIXTURE. FOR RIGGING PURPOSES, SECURE THE TOP SAFETY CABLE TO A FIXED POINT AND LOOP EACH SUBSEQUENT SAFETY CABLE THROUGH THE ONE ABOVE IT.

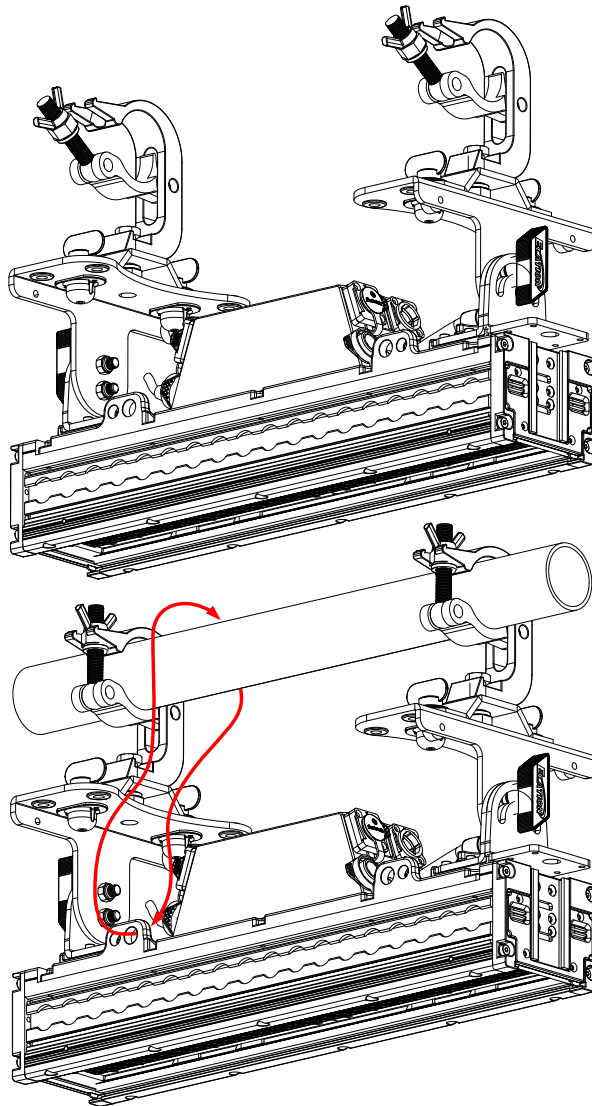

MOUNTING THE FIXTURE ON A TRUSS USING CLAMPS WITH OMEGA BRACKETS

When mounting the fixture to a truss, be sure to secure an appropriately rated professional grade rigging clamp to the included **Omega Brackets** using an M10 or M12 screw fitted through the center hole of the **Omega Brackets**. The fixture provides a built-in rigging point for a **SAFETY CABLE**. Be sure to use the designated rigging points for the safety cable.

INSTALLATION GUIDELINES

L-TRACK MOUNTING

The L-track mounting system enables the user to slide the mounting clamps along the tracks and secure them in the desired position. The L-tracks are situated on the rear, and along the sides of the fixture. Special L-track mounting clamps, which feature an L-track attachment rail instead of a mounting bolt hole, are available in both standard and extended lengths. Similarly, L-track adapters are also available, which can be fitted to any standard mounting clamp.

To attach an L-track clamp or adapter, simply insert the attachment rail into the matching track on the fixture, slide it to the desired location, and tighten the fastener knob on the attachment to ensure it is securely in place.

When utilizing the L-track for rigging, the maximum capacity is 12 fixtures, or 187 lbs (84.82 kg).

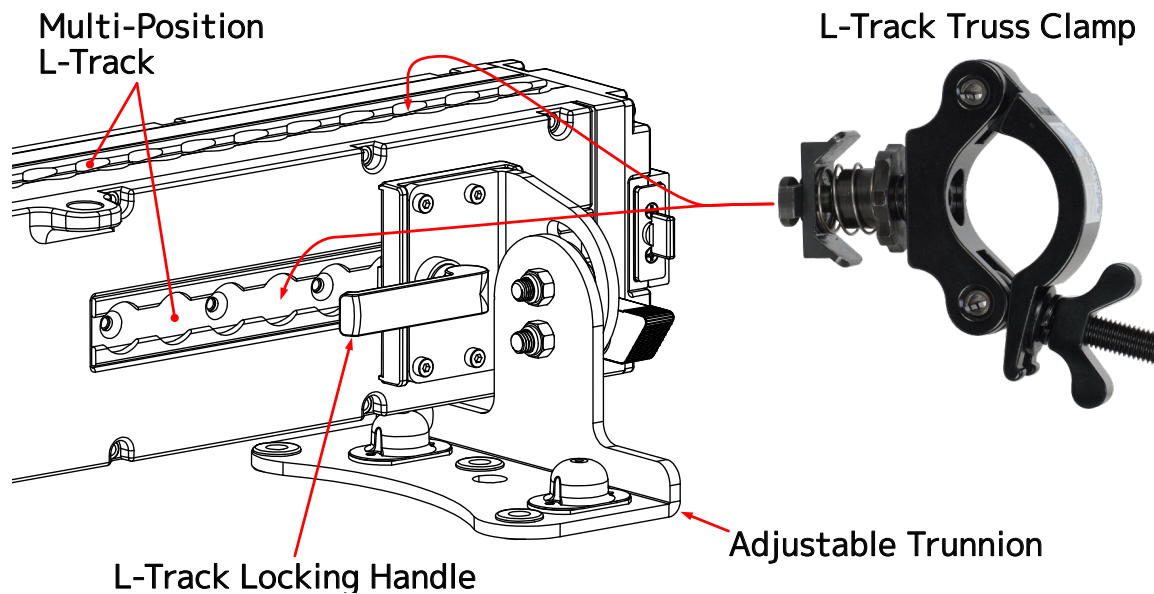

INSTALLATION GUIDELINES

FIXTURE INSTALLATION

The Elation SIX+ BAR S is fully operational in three different mounting positions, hanging upside-down, mounted sideways on trussing, or set on a flat level surface. Always use and install the supplied safety cable as a safety measure to prevent accidental damage and/or injury in the event the clamp fails.

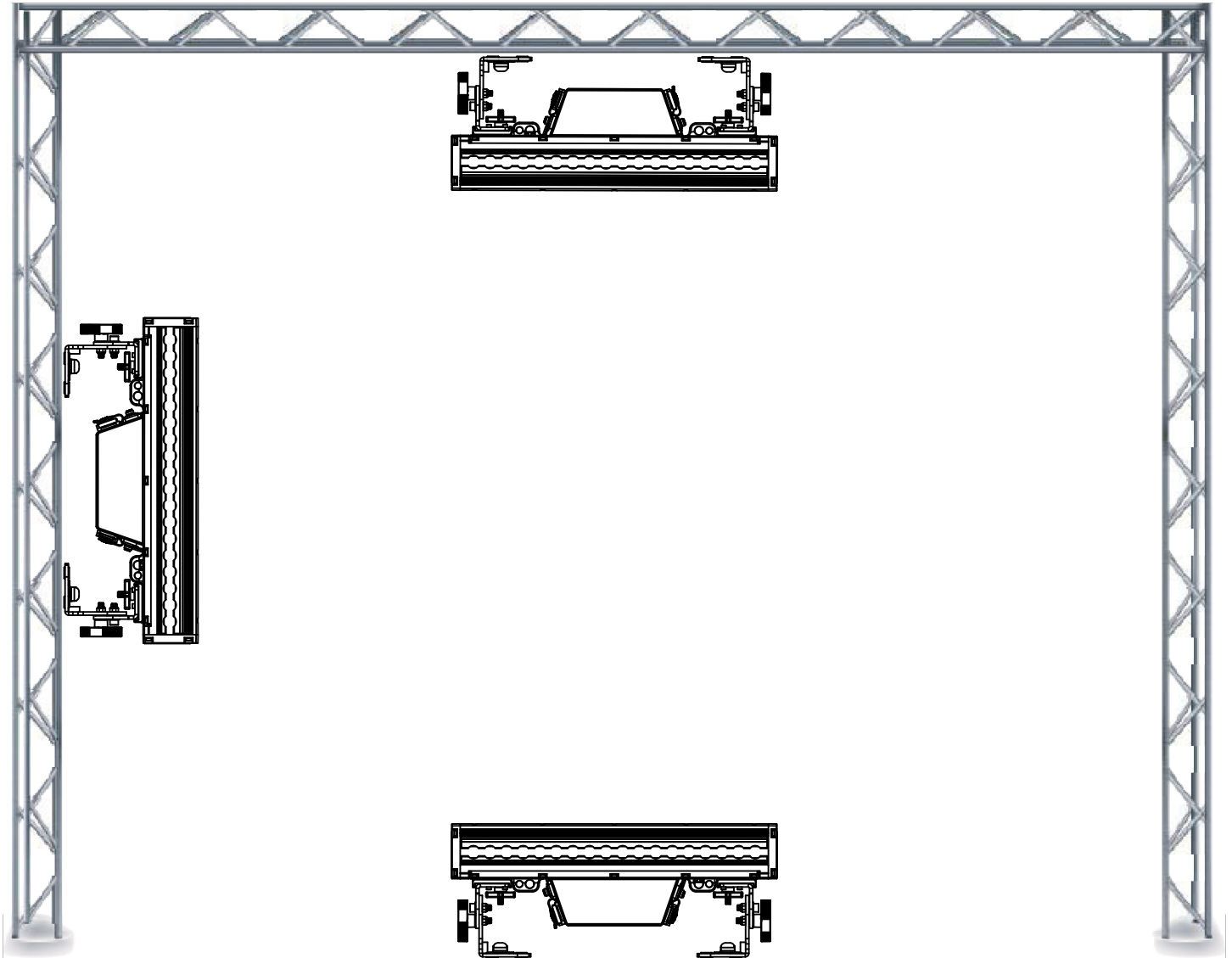

FALLING FIXTURES CAN CAUSE SEVERE INJURY OR SERIOUS EQUIPMENT DAMAGE! FOR THIS REASON, FIXTURES SHOULD BE INSTALLED AND INSPECTED ONLY BY QUALIFIED PERSONNEL. DO NOT INSTALL THE UNIT IF YOU LACK THE QUALIFICATIONS TO DO SO, OR IF YOU HAVE DOUBTS ABOUT THE SAFETY AND SECURITY OF THE INSTALLATION SETUP OR LOCATION!



ALWAYS ATTACH A SAFETY CABLE WHENEVER INSTALLING THIS FIXTURE IN A SUSPENDED ENVIRONMENT TO ENSURE THE FIXTURE WILL NOT FALL IF THE CLAMP FAILS.

INSTALLATION GUIDELINES

FIXTURE INTERCONNECTORS

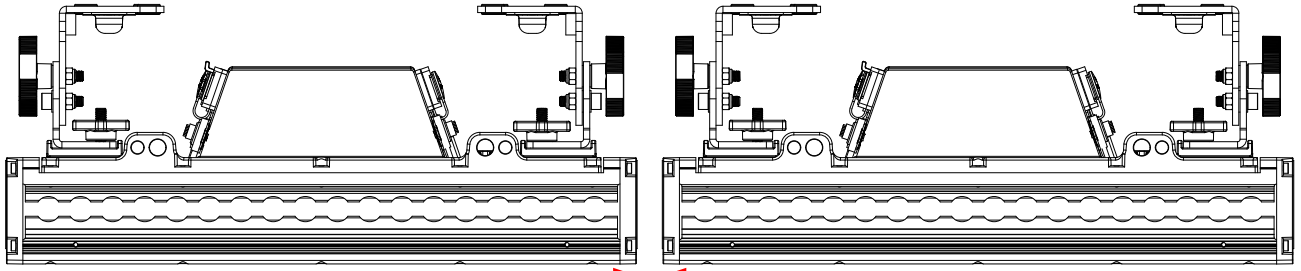

To connect the fixtures end-to-end, ensure that the interconnect slots are flush.

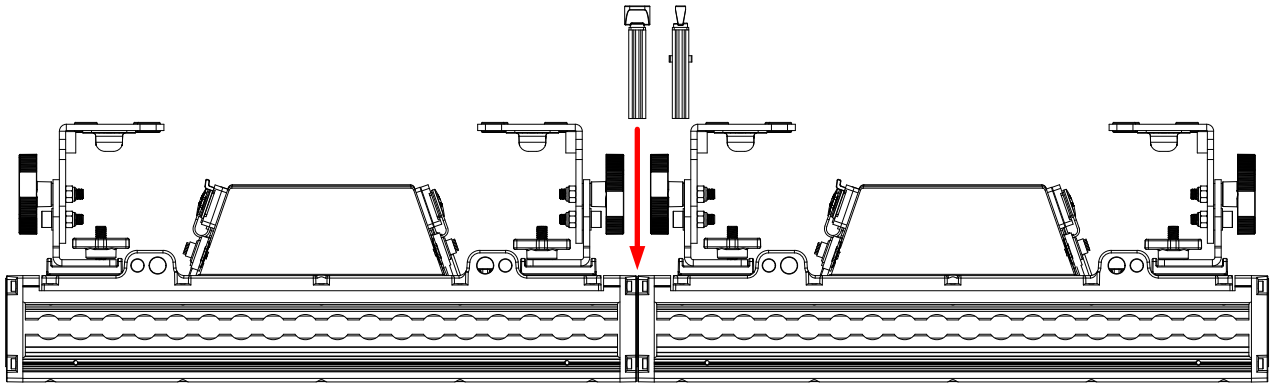

Fully insert the splice lock. Once the splice lock is fully seated, turn the lock tab to engage it, rotating the lock tab into the interconnect lock slot.

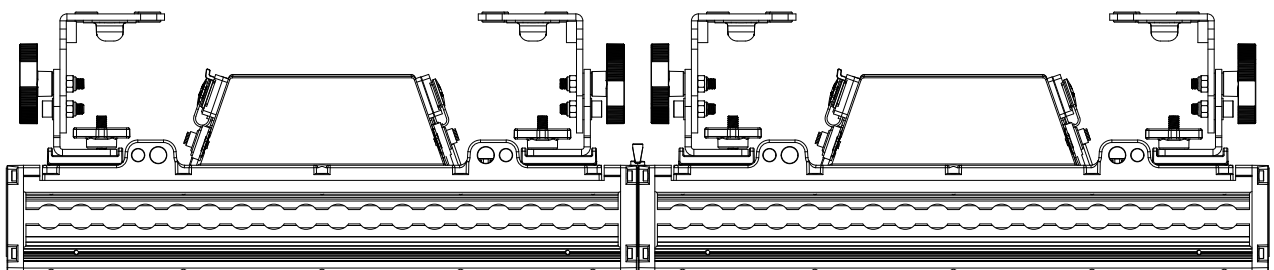
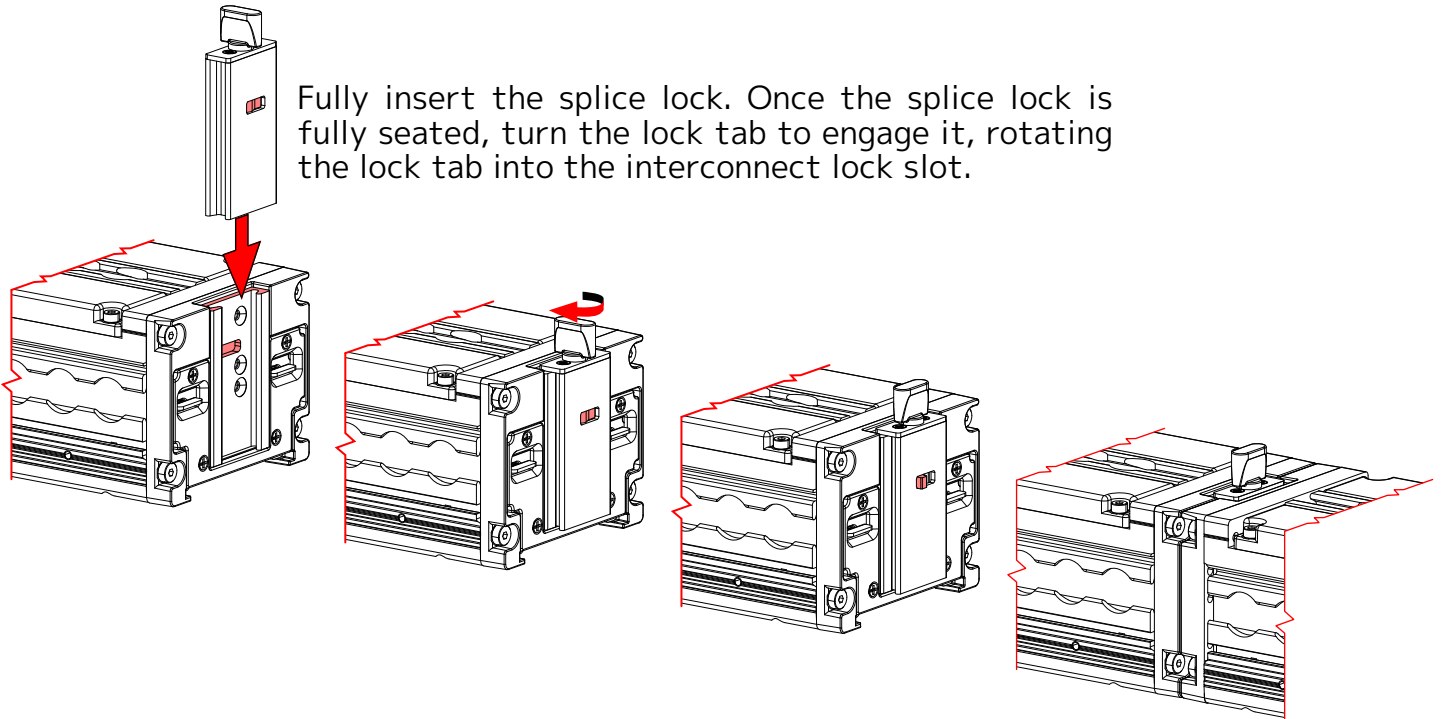

INSTALLATION GUIDELINES

RIGGING LIMIT

HORIZONTAL SUSPENSION

When utilizing the provided Trunnions for rigging in a horizontal array orientation, the maximum capacity 96 lbs (43.54 kg), which is sufficient for 6 fixtures. However, if employing the L-Track for rigging in the same orientation, the maximum capacity increases to 187 lbs (84.82 kg), which is sufficient for 12 fixtures.

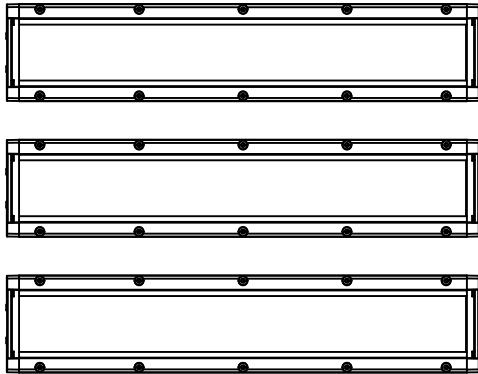

VERTICAL SUSPENSION

When rigging vertically with Interconnect Splices to connect fixtures, the maximum capacity is 187 lbs (84.82 kg), which is sufficient for 12 fixtures.



ATTENTION! It is crucial to ensure that any arrangement consisting of multiple interconnected fixtures, whether in a vertical, horizontal, or shaped configuration, is securely and properly supported and fixed to prevent any movement that may arise from lateral forces, such as wind or physical contact with a person or other object.



IF THE FIXTURES ARE PART OF A LARGER ARRAY, ATTACH A SAFETY CABLE TO THE SAFETY CABLE ATTACHMENT POINT ON THE BACK OF EACH FIXTURE. FOR RIGGING PURPOSES, SECURE THE TOP SAFETY CABLE TO A FIXED POINT AND LOOP EACH SUBSEQUENT SAFETY CABLE THROUGH THE ONE ABOVE IT.

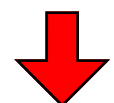

INSTALLATION GUIDELINES

POWER AND DATA CABLES



REGARDLESS OF FIXTURE ORIENTATION, TO MAINTAIN THE IP65 RATING INTEGRITY OF THE FIXTURE, ALL CABLES MUST BE ROUTED TOWARDS THE GROUND TO PREVENT WATER ACCUMULATION AROUND THE CONNECTIONS.

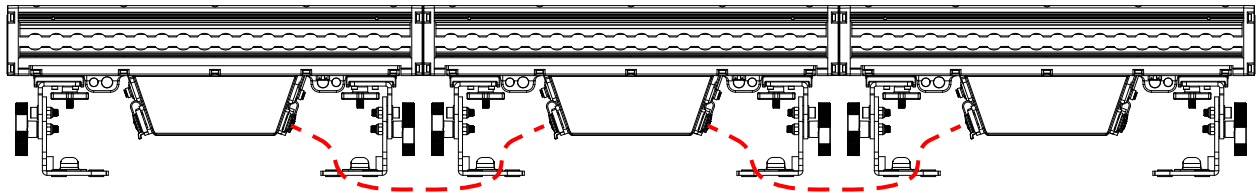
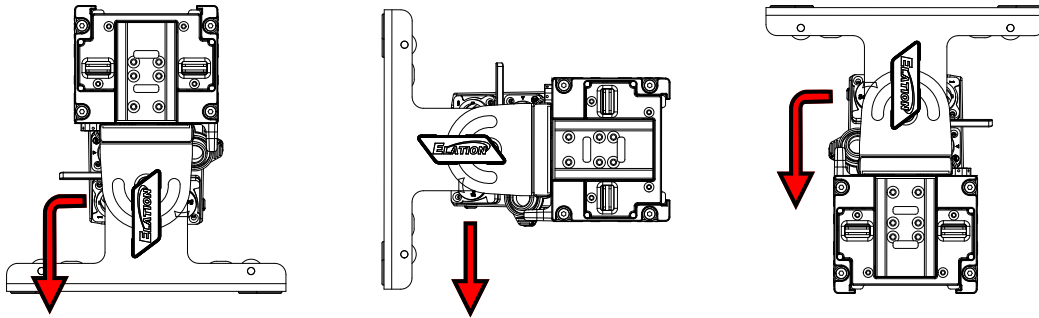

INSTALLATION GUIDELINES

POTENTIAL INTERNAL FIXTURE DAMAGE FROM EXTERNAL SOURCES OF LIGHT BEAMS

External sources of light beams from direct sunlight, lighting moving head fixtures, and lasers, which are focused directly towards the exterior housing and/or penetrate the front lens opening of ELATION lighting fixtures, can cause severe internal damage including burning to optics, dichroic color filters, glass and metal gobos, prisms, animation wheels, frost filters, iris, shutters, motors, belts, wiring, discharge lamps, and LEDs. **NOTE: NOT ALL FEATURES LISTED ARE AVAILABLE ON ALL FIXTURES.**

This issue is not specific only to ELATION lighting fixtures, it is a common issue with lighting fixtures from all manufacturers. Although there is no true way to fully prevent this issue from happening, the guidelines below can prevent any potential damage from occurring if followed. Contact ELATION Service for more details.

DO NOT EXPOSE THE FIXTURE AND/OR FRONT LENS OPENING TO LIGHT BEAMS FROM DIRECT SUNLIGHT, OTHER LIGHTING MOVING HEAD FIXTURES, AND LASERS WHILE UNPACKING, INSTALLATION, USE, AND EXTENDED IDLE TIMES OUTDOORS. DO NOT FOCUS A LIGHT BEAM FROM ONE LIGHTING FIXTURE DIRECTLY TOWARDS ANOTHER.

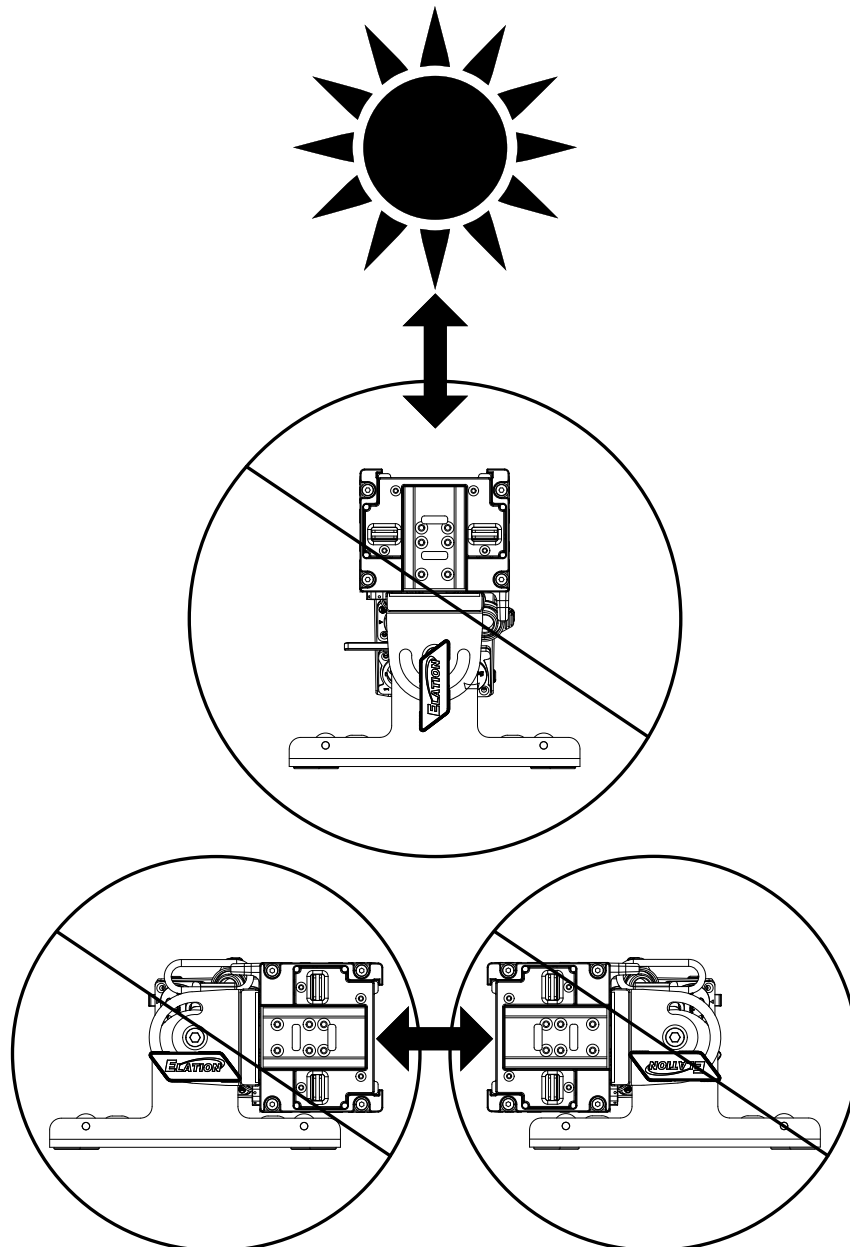

ACCESSORY INSTALLATION - FROST LENS

1. Slide lock levers downward to retract the locking tabs.

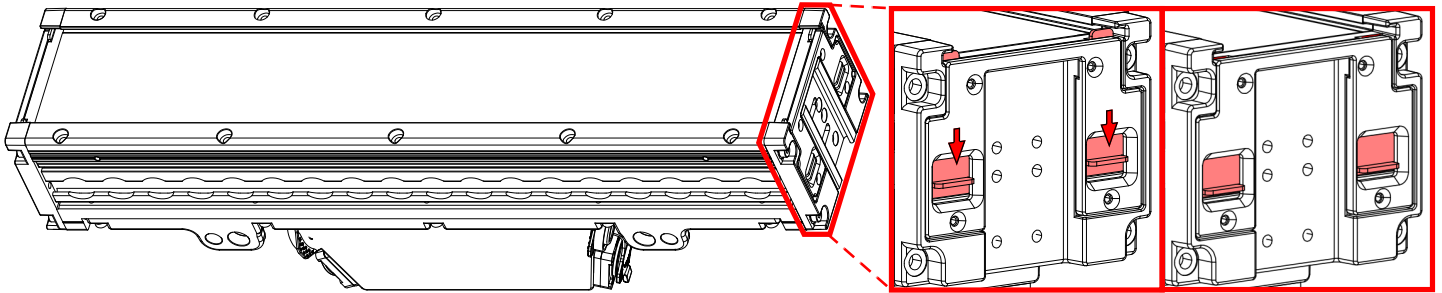

2. Install the Frost Lens by sliding it into the lens groove.

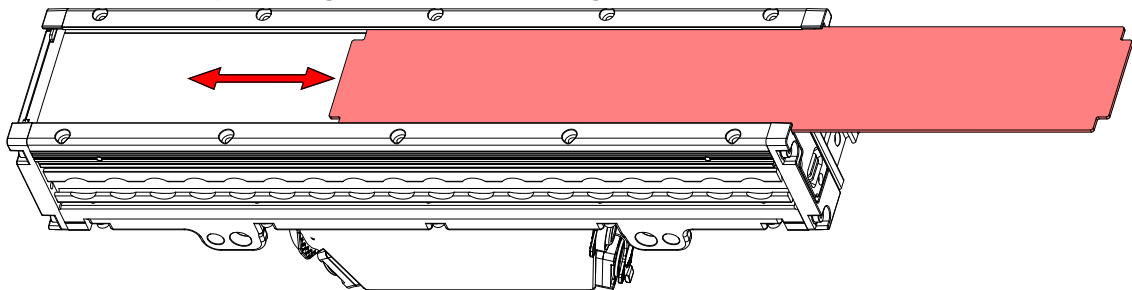

3. With the Frost Lens installed, slide levers upward to lock it in place.

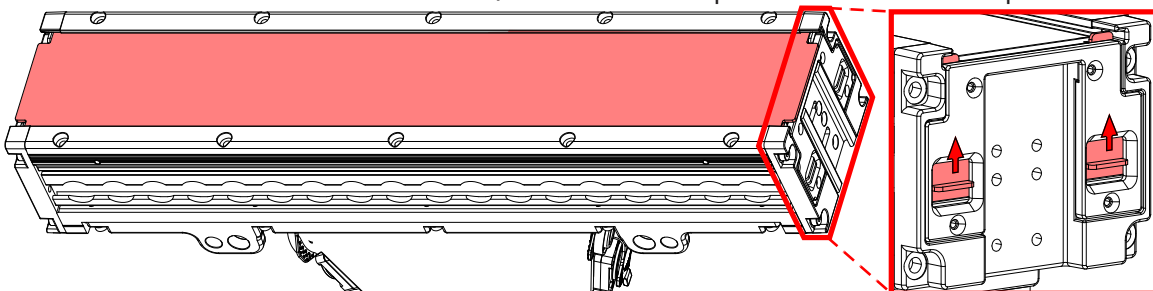

ACCESSORY INSTALLATION - GLARE SHIELD

1. Locate two Glare Shield mounting screw holes on side of fixture.

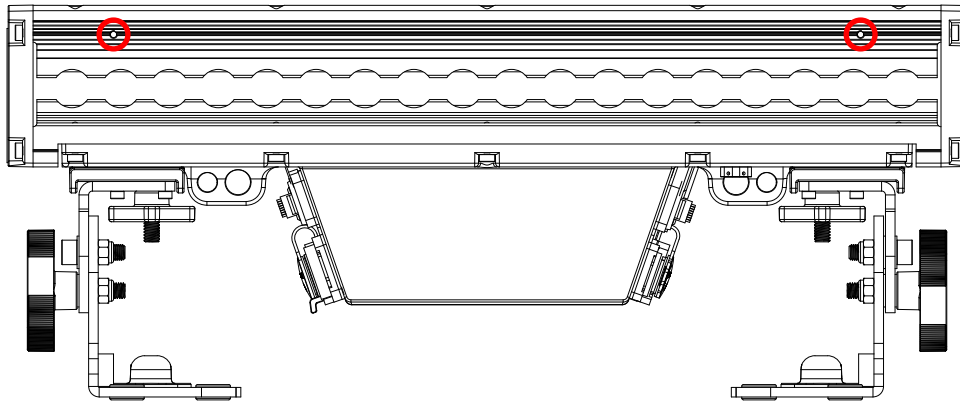

2. Align the thumbscrews of the Glare Shield with the mounting screw holes and insert them.

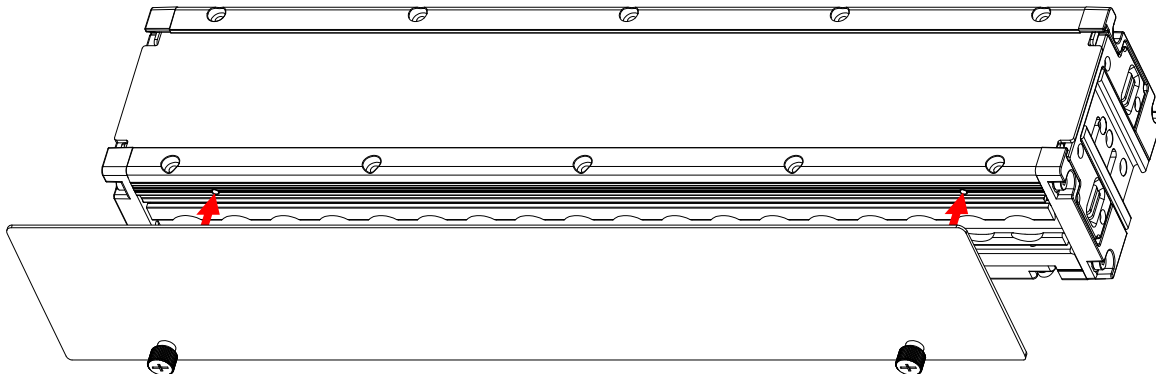

3. Tighten the two thumbscrews to secure Glare Shield. Thumbscrews can also be tightened with a Phillips screw driver.

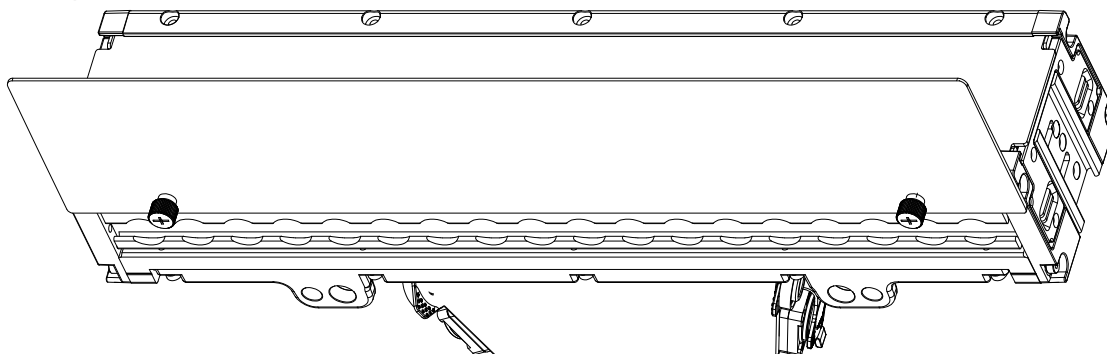

ARIA SETUP AND GUIDELINES

2GHZ Versus Sub-Gig (GHz) Frequencies:

Sub-GHz frequencies provide superior reliability and range compared to higher frequencies, making them perfect for consistent communication across vast distances or in difficult conditions. Devices operating in the sub-GHz range, which refers to frequencies below 1 GHz, can transmit signals over significant distances and can penetrate physical barriers such as walls and buildings more effectively. Additionally, these frequencies experience less interference compared to those in the heavily congested 2.4-GHz band, which is commonly used by wireless devices.

In the United States, the 900 MHz band is a versatile frequency range that is utilized by various services, with the FCC overseeing its allocation and regulation.

In the European Union, the 868 MHz frequency is designated by ETSI as the Sub-Gig frequency.

In summary, if an application demands high data rates and more bandwidth in urban or densely populated areas where interference management is feasible, the 2.4 GHz frequency is a suitable choice. On the other hand, for applications requiring long-range communication and better obstacle penetration, particularly in rural or industrial settings with fewer regulatory constraints, a sub-GHz frequency (<1 GHz) is a better option.

Installation Recommendations:

With the many factors that affect and/or interrupt a wireless signal such as walls, glass, metal, objects, and people, it is highly recommended to:

- Install devices a minimum of 9.8 ft. (3m) above audiences and/or ground level where practical.
- Adjust the wireless antenna in a vertical upright position
- Position devices in direct line of sight of the controlling device

Careful planning and testing of the selected installation location is critical to ensure optimum and reliable wireless operation.

**9.8 ft (3m)
Above Ground**

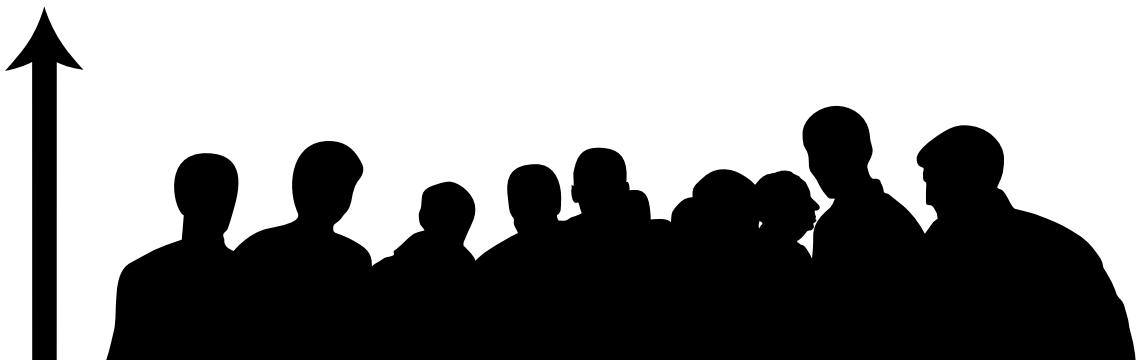

ARIA SETUP AND GUIDELINES

GENERAL INFORMATION

The Aria Bluetooth app has the ability to connect wirelessly to any device that has Aria wireless DMX installed and has Bluetooth enabled.

Before installing the fixture in a remote location, double check that the fixture's main power is switched on, and that the Bluetooth function has been enabled in the fixture's system menu. Certain fixtures may have Bluetooth disabled by default. If this function is disabled, then the fixture cannot be configured remotely using the Aria app, and will have to be configured directly from the fixture's control screen.

Additionally, the user should consider setting the fixture's No DMX setting to "Hold Last". This will allow the fixture to continue running using the current settings, even if the Aria app device moves out of range, the app is closed, or the signal is otherwise interrupted, minimizing disruption in the operation of the fixtures.

LEGACY DEVICES

Please note that legacy connected devices, such as those using Wifly, E-Fly, or Magfly, are not compatible with this app. For such legacy devices, the use of a bridge is recommended, as the bridge can communicate with these devices via its SM220 protocol.

The Aria X2 BLE app is currently available from the Apple app store.

FIXTURE IDENTIFICATION

Aria compatible devices can be identified and connected via the **Fixtures** tab in the app. This tab displays a field of twenty-four buttons that can be assigned to Aria compatible devices that are within range, and the buttons will automatically be assigned to devices in the order in which they are discovered. If more than twenty-four units are within range, it may be necessary to use the filter feature to search for the desired fixture. Button location can be edited by selecting the configuration key, then the user can drag and drop the buttons to the desired location and hit save to keep changes. Once a device is known to the app, it can also be assigned to a particular button. From that point forward, the assigned device will always be assigned to that button location.

IMPORTANT NOTE: For version 0.65 or higher, a shared system password is required to connect to any device.

Unlike wireless DMX, Bluetooth is a connect first protocol. To connect to a device or fixture, tap the assigned button in the **Fixtures** tab. If the connection is successful, a green frame will appear around the button, indicating that the app was able to retrieve the current channel values from the fixture. The app must be connected to a fixture in order to use its channel controls or view and change settings. Please note that not all Aria devices have channel controls.

Additionally, each fixture can only be connected to one device with the app at any given time. Once a fixture is connected to the app installed on one device, any other devices will be blocked from connecting. As a result, when setting up a new fixture for the first time, best practice is to have only a single user with the app open within range, in order to ensure that the fixture pairs to the intended user's device.

ARIA SETUP AND GUIDELINES

The second table section shows all Aria devices detected in range. A checkmark indicates the device is currently assigned to a button. If more than 24 devices are within range, the user may remove or add devices to the buttons list by tapping a row to check or uncheck a device. If all buttons are full, it will be necessary to uncheck a device before adding another.

Filter: The user can filter which Aria devices get button assignments by tapping “filter” at the top of the view. A popup will appear where the user can enter text to filter devices by username, model name, or manufacturer. **Please note that these searches are case sensitive.**

Note: If a device shows an asterisk (*) it means that there is no fixture profile currently available, and therefore there will be limited support available for that device. The user will still be able to connect and adjust channels if the device supports that feature, but the user will not be able to view how many channels the device has or the channel names.

SECURITY

Each fixture must have a password saved to be secure. When a new fixture is installed for the first time, its password will automatically be set to the app’s system password on first connection. Once the password has been entered, the user will need to exit out to the main page containing the fixture buttons, then de-select and re-select the fixture to lock in the password. From that point forward only, controlling devices that use the correct password can connect to this fixture. **This security is now required by law in most jurisdictions.**

The app will detect any Aria capable fixture within range, even if the app does not have the password to that fixture and therefore cannot access that fixture. If that fixture is selected in the app, the green frame will momentarily appear around that fixture’s button, but then disappear. This indicates that the fixture is visible but inaccessible.

REMOTE DEVICE MANAGEMENT (RDM)

NOTE: In order for RDM to work properly, RDM enabled equipment must be used throughout the entire system, including DMX data splitters and wireless systems.

Remote Device Management (RDM) is a protocol that sits on top of the DMX512 data standard for lighting, and allows the DMX systems of the fixtures to be modified and monitored remotely. This protocol is ideal for instances in which a unit is installed in a location that is not easily accessible.

With RDM, the DMX512 system becomes bi-directional, allowing a compatible RDM enabled controller to send out a signal to devices on the wire, as well as allowing the fixture to respond (known as a GET command). The controller can then use its SET command to modify settings that would typically have to be changed or viewed directly via the unit's display screen, including the DMX Address, DMX Channel Mode, and Temperature Sensors.

FIXTURE RDM INFORMATION:

Device ID	Device Model ID	RDM Code	Personality ID
0x0049	0x0049 XXXX	22A6	Dimmer 1CH RGB 3CH Color 6CH Color & Dimmer 9CH CMY 13CH CMY Extended 16CH Standard 16CH Extended 22CH 2 Cell Standard 22CH 2 Cell Extended 34CH 6 Cell Standard 46CH 6 Cell Extended 82CH Raw 6 Cell 36CH

Please be aware that **not all RDM devices support all RDM features**, and therefore it is important to check beforehand to ensure that the equipment that you are considering includes all of the features that you require.

The following parameters are accessible in RDM on this device:

[0x0001]	Discovery Unique Branch
[0x0050]	Supported Parameters
[0x0060]	Device Info
[0x0070]	Product Detail ID List
[0x0080]	Device Model Description
[0x0081]	Manufacturer Label
[0x0082]	Device Label
[0x00C0]	Software Version Label
[0x00E0]	DMX Personality
[0x00E1]	DMX Personality Description
[0x00F0]	DMX Start Address
[0x0200]	Sensor Definition
[0x0201]	Sensor Value
[0x0400]	Device Hours
[0x1000]	Identify Device

SYSTEM MENU

The fixture includes an easy to navigate system menu. The control panel display is located on the rear panel of the fixture (see image below) and provides access to the main system menu, where all necessary system adjustments are made to the fixture. During normal operation, pressing the MODE button once will access the fixture's main menu. Once in the main menu you can navigate through the different functions and access the sub-menus with the DOWN and UP buttons. Once you reach a field that requires adjusting, press the ENTER button to activate that field and use the DOWN and UP buttons to adjust the field. Pressing the ENTER button once more will confirm the setting. Exit the main menu at any time without making any adjustments by pressing the MODE button.

PERMANENT INSTALLATION SETTING AND PHANTOM TOUCH

A phantom touch on an LCD screen is an unexpected, unprompted touch that seems to occur without any physical contact, like a raindrop. When installing any fixture in a permanent setting, we recommend setting your display to lock after 10-seconds and not the **OFF** setting. Units in a permanent setting are exposed to various conditions, if a unit is set to **OFF**, the display may interpret a raindrop as a command and change the fixture's setting through a phantom touch. Setting the display to lock after 10-seconds, and not setting a the display to **OFF**, prevents this scenario. To unlock the screen, press UP, DOWN, UP, DOWN, ENTER.

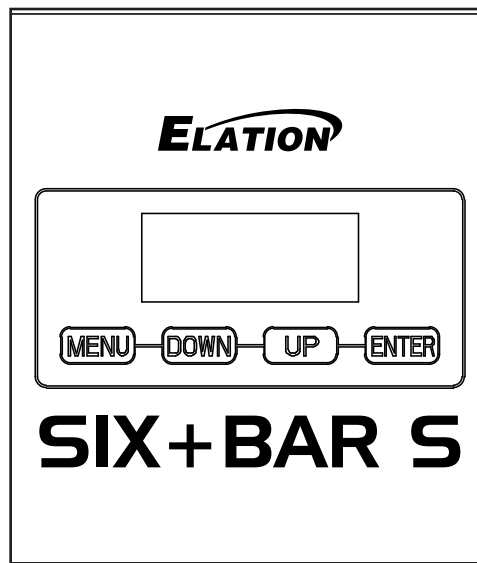

AN ELATION C-LOADER II CAN ALSO BE USED TO UPDATE THE FIXTURE TO THE LATEST SOFTWARE. To order this device, please contact Elation Support for further details.

Detailed instructions can be found online at www.elationlighting.com.

ELATION SERVICE USA - Monday - Friday 8:00am to 4:30pm PST
323-582-3322 | support@elationlighting.com

ELATION SERVICE EUROPE - Monday - Friday 08:30 to 17:00 CET
+31 45 546 85 63 | support@elationlighting.eu

SYSTEM MENU

MAIN MENU		OPTIONS / VALUES (Default Settings in BOLD)		
DMX	DMX Address	001 - 512		
	DMX Mode	1CH Dimmer		
		3CH RGB		
		6CH Color		
		9CH Color & Dimmer		
		13CH CMY		
		16CH CMY Extended		
		16CH Standard		
		22CH Extended		
		22CH 2 Cell Standard		
		34CH 2 Cell Extended		
		46CH 6 Cell Standard		
		82CH 6 Cell Extended		
		36CH Raw 6 Cell		
		SixBar 500 Emulation (See Emulated DMX Traits on page 30)	6 Channel	
7 Channel				
11 Channel				
13 Channel				
36 Channel				
No DMX Status	Hold Last , Fade to Black, Standalone			
Protocol	Select Signal	DMX / Art-Net / sACN / Klingnet /Aria In - DMX Out / DMX In - Aria Out		
	Universe	0 - 32767 (Default = 1)		
	IP Address	2.x.x.x		
	Subnet Mask	255.0.0.0		
	Ethernet DMX Out	Off / On		
Aria	Aria Channel	0 -14		
Control	Manual Control	Dimmer	000% - 100%	
		Red	0 - 255	
		Green	0 - 255	
		Blue	0 - 255	
		Lime	0 - 255	
		Amber	0 - 255	
		UV	0 - 255	
		CCT	2400K - 8500K (Default = 6000K).	
	Virtual Color	See Color Macros		
	Primary	On / Off		
	Secondary	On / Off		
	Self Test	All		
		Dimmer		
Color				
Settings	Dim Modes	Standard , Stage, TV, Architectural, Theatre, Stage 2		
		Dim Speed	0s - 10s (Default = 0.1s)	
	Dim to Warm	On / Off		
	Dim Curves	Linear, Square, Square Inverse, S-Curve		
	LED Refresh Rate	900Hz - 1500Hz (1200 Hz), 2500Hz, 4000Hz, 5000Hz, 6000Hz, 10KHz, 15KHz, 20KHz, 25KHz		
	LED Power Limit	50%, 60%, 70%, 80%, 90%, 100%		
	Pixel Flip	Yes / No		
	Display	Screen Delay	10s - 5min (Default = 1 min)	
		Screen Lock	Off , 10s - 5 min, Key Lock	
Rotate Display		Yes / No / Auto		
Reset Defaults	Yes / No			

SYSTEM MENU

MAIN MENU		OPTIONS / VALUES (Default Settings in BOLD)	
Information	Time	Current Run Time	
		Total Run Time	
		Last Run Time	
	Temperature	Current	
		Max Resettable	
	Humidity	Current	
		Max Resettable	
	DMX Values	Red	
		Green	
		...	
Product IDs	RDM UID		
Error Logs	Fixture Errors		
Software Version	Vx.x		
Service (Passcode = 50)	Calibration	All Red 0 - 255	
		All Green 0 - 255	
		All Blue 0 - 255	
		All Lime 0 - 255	
		All Amber 0 - 255	
		All UV 0 - 255	
		Red 1 0 - 255	
		Green 1 0 - 255	
		Blue 1 0 - 255	
		Lime 1 0 - 255	
		Amber 1 0 - 255	
		UV 1 0 - 255	
		
		Red 6 0 - 255	
		Green 6 0 - 255	
		Blue 6 0 - 255	
		Lime 6 0 - 255	
		Amber 6 0 - 255	
		UV 6 0 - 255	
		Reset Last Run	Yes / No
	Reset Error Logs	Yes / No	

NOTE ON EMULATION DMX TRAITS (see page 30)

To ensure the SIX+ BAR S can be integrated seamlessly alongside original SixBar fixtures, great care has been taken to ensure that the new LED array colors match the original. A unique SixBar Emulation DMX mode has been developed, so that the new fixtures can be controlled with the same DMX mapping as the original. The color mixing has also been calibrated to virtually emulate the White LED included in the SixPar array and an output limit master setting has been added so your new lights don't overpower any older fixtures in the rig.

DIMMER MODES & CURVES

DIMMER

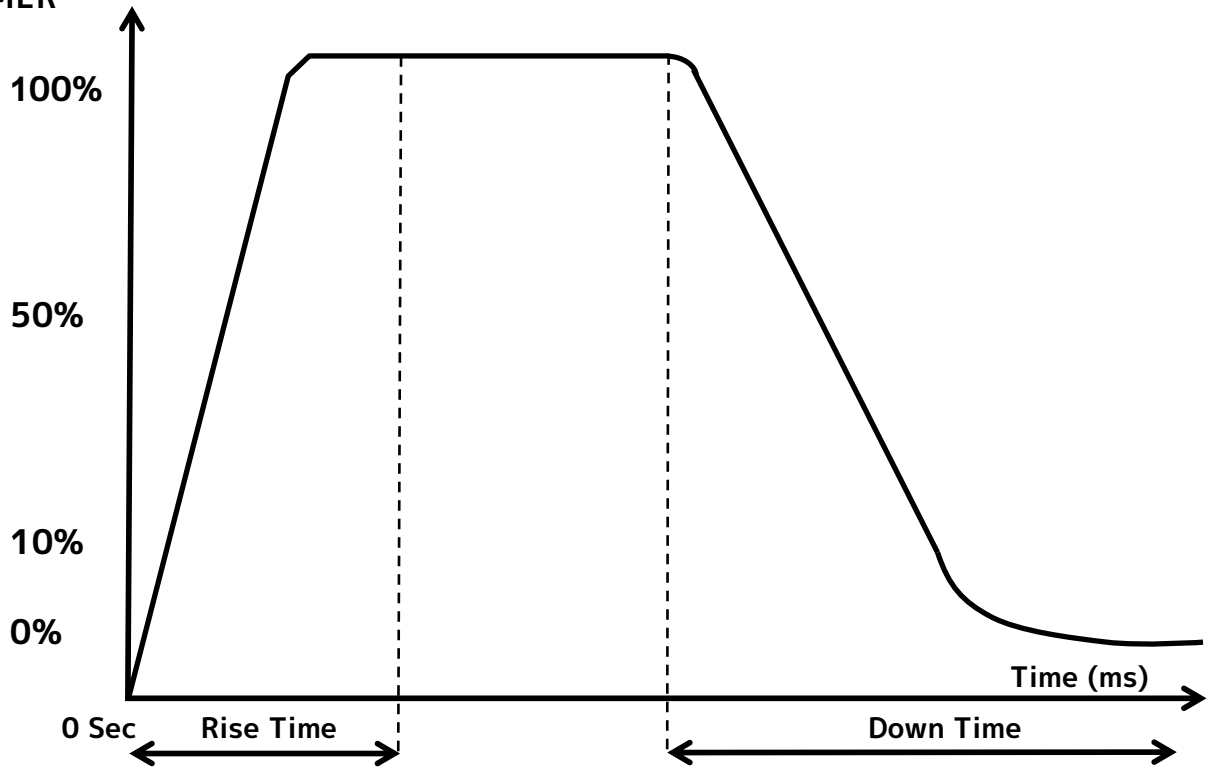

Dimming Curve Ramp Effect	0 sec Fade Time		1 sec Fade Time	
	Rise Time (ms)	Down Time (ms)	Rise Time (ms)	Down Time (ms)
Standard (default)	0	0	0	0
Stage	780	1100	1540	1660
TV	1180	1520	1860	1940
Architectural	1380	1730	2040	2120
Theatre	1580	1940	2230	2280
Stage 2	0	1100	0	1660

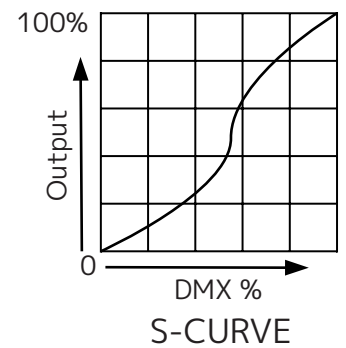
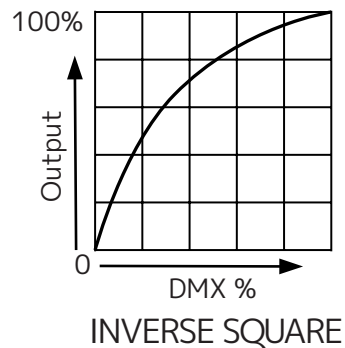
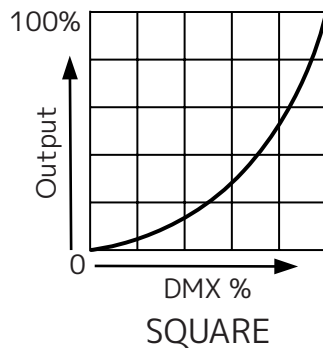
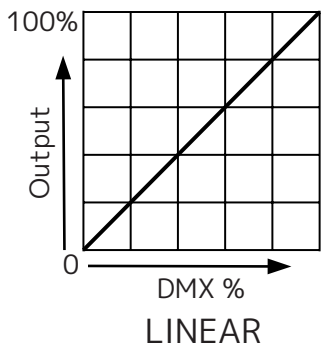

DMX TRAITS

Dim. 1CH	RGB 3CH	Col 6CH	Col & Dim 9CH	CMY 13CH	CMY Ext 16CH	Std. 16CH	Ext. 22CH	2 Cell Std 22CH	2 Cell Ext 34CH	6 Cell Std 46CH	6 Cell Ext 82CH	Raw 6 Cell 36CH	DMX Values	Function	Snap	Default Value
1			1	1	1	1	1	1	1	1	1		0-255	Dimmer Intensity 0 → 100%		0
			2	2	2	2	2	2	2	2	2		0-255	Dimmer Fine Fine Intensity Control		0
			3	3	3	3	3	3	3	3	3			Shutter/Strobe	X	50
		0-31												Shutter closed		
		32-63												No function (shutter open)		
		64-95												Strobe effect slow to fast		
		96-127												No function (shutter open)		
		128-159												Pulse-effect in sequences		
		160-191												No function (shutter open)		
		192-223												Random strobe effect slow to fast		
		224-255	No function (shutter open)													
	1	1	4			4	4	4	4	4	4	1	0-255	Red Red Saturation 0 → 100%		0
							5	5	5	5	5		0-255	Red Fine Find Red Control		0
	2	2	5			5	6	5	6	5	6	2	0-255	Green Green Saturation 0 → 100%		0
							7	7	7	7	7		0-255	Green Fine Fine Green Control		0
	3	3	6			6	8	6	8	6	8	3	0-255	Blue Blue Saturation 0 → 100%		0
							9	9	9	9	9		0-255	Blue Fine Fine Blue Control		0
		4	7			7	10	7	10	7	10	4	0-255	Lime Lime Saturation 0 → 100%		0
							11	11	11	11	11		0-255	Lime Fine Fine Lime Control		0
		5	8			8	12	8	12	8	12	5	0-255	Amber Amber Saturation 0 → 100%		0
							13	13	13	13	13		0-255	Amber Fine Fine Amber Control		0
		6	9			9	14	9	14	9	14	6	0-255	UV UV Saturation 0 → 100%		0
							15	15	15	15	15		0-255	UV Fine Fine UV Control		0
								10	16	10	16	7	0-255	Red 2 Red Saturation 0 → 100%		0
									17		17		0-255	Red Fine 2 Fine Red Control		0
								11	18	11	18	8	0-255	Green 2 Green Saturation 0 → 100%		0
									19		19		0-255	Green Fine 2 Fine Green Control		0
								12	20	12	20	9	0-255	Blue 2 Blue Saturation 0 → 100%		0
									21		21		0-255	Blue Fine 2 Fine Blue Control		0
								13	22	13	22	10	0-255	Lime 2 Lime Saturation 0 → 100%		0
									23		23		0-255	Lime Fine 2 Fine Lime Control		0
								14	24	14	24	11	0-255	Amber 2 Amber Saturation 0 → 100%		0
									25		25		0-255	Amber Fine 2 Fine Amber Control		0
								15	26	15	26	12	0-255	UV 2 UV Saturation 0 → 100%		0
									27		27		0-255	UV Fine 2 Fine UV Control		0

DMX TRAITS

Dim. 1CH	RGB 3CH	Col 6CH	Col & Dim 9CH	CMY 13CH	CMY Ext 16CH	Std. 16CH	Ext. 22CH	2 Cell Std 22CH	2 Cell Ext 34CH	6 Cell Std 46CH	6 Cell Ext 82CH	Raw 6 Cell 36CH	DMX Values	Function	Snap	Default Value
										16	28	13	0-255	Red 3 Red Saturation 0 → 100%		0
											29		0-255	Red Fine 3 Fine Red Control		0
										17	30	14	0-255	Green 3 Green Saturation 0 → 100%		0
											31		0-255	Green Fine 3 Fine Green Control		0
										18	32	15	0-255	Blue 3 Blue Saturation 0 → 100%		0
											33		0-255	Blue Fine 3 Fine Blue Control		0
										19	34	16	0-255	Lime 3 Lime Saturation 0 → 100%		0
											35		0-255	Lime Fine 3 Fine Lime Control		0
										20	36	17	0-255	Amber 3 Amber Saturation 0 → 100%		0
											37		0-255	Amber Fine 3 Fine Amber Control		0
										21	38	18	0-255	UV 3 UV Saturation 0 → 100%		0
											39		0-255	UV Fine 3 Fine UV Control		0
										22	40	19	0-255	Red 4 Red Saturation 0 → 100%		0
											41		0-255	Red Fine 4 Fine Red Control		0
										23	42	20	0-255	Green 4 Green Saturation 0 → 100%		0
											43		0-255	Green Fine 4 Fine Green Control		0
										24	44	21	0-255	Blue 4 Blue Saturation 0 → 100%		0
											45		0-255	Blue Fine 4 Fine Blue Control		0
										25	46	22	0-255	Lime 4 Lime Saturation 0 → 100%		0
											47		0-255	Lime Fine 4 Fine Lime Control		0
										26	48	23	0-255	Amber 4 Amber Saturation 0 → 100%		0
											49		0-255	Amber Fine 4 Fine Amber Control		0
										27	50	24	0-255	UV 4 UV Saturation 0 → 100%		0
											51		0-255	UV Fine 4 Fine UV Control		0

DMX TRAITS

Dim. 1CH	RGB 3CH	Col 6CH	Col & Dim 9CH	CMY 13CH	CMY Ext 16CH	Std. 16CH	Ext. 22CH	2 Cell Std 22CH	2 Cell Ext 34CH	6 Cell Std 46CH	6 Cell Ext 82CH	Raw 6 Cell 36CH	DMX Values	Function	Snap	Default Value
										28	52	25	0-255	Red 5 Red Saturation 0 → 100%		0
											53		0-255	Red Fine 5 Fine Red Control		0
										29	54	26	0-255	Green 5 Green Saturation 0 → 100%		0
											55		0-255	Green Fine 5 Fine Green Control		0
										30	56	27	0-255	Blue 5 Blue Saturation 0 → 100%		0
											57		0-255	Blue Fine 5 Fine Blue Control		0
										31	58	28	0-255	Lime 5 Lime Saturation 0 → 100%		0
											59		0-255	Lime Fine 5 Fine Lime Control		0
										32	60	29	0-255	Amber 5 Amber Saturation 0 → 100%		0
											61		0-255	Amber Fine 5 Fine Amber Control		0
										33	62	0	0-255	UV 5 UV Saturation 0 → 100%		0
											63		0-255	UV Fine 5 Fine UV Control		0
										34	64	31	0-255	Red 6 Red Saturation 0 → 100%		0
											65		0-255	Red Fine 6 Fine Red Control		0
										35	66	32	0-255	Green 6 Green Saturation 0 → 100%		0
											67		0-255	Green Fine 6 Fine Green Control		0
										36	68	33	0-255	Blue 6 Blue Saturation 0 → 100%		0
											69		0-255	Blue Fine 6 Fine Blue Control		0
										37	70	34	0-255	Lime 6 Lime Saturation 0 → 100%		0
											71		0-255	Lime Fine 6 Fine Lime Control		0
										38	72	35	0-255	Amber 6 Amber Saturation 0 → 100%		0
											73		0-255	Amber Fine 6 Fine Amber Control		0
										39	74	36	0-255	UV 6 UV Saturation 0 → 100%		0
											75		0-255	UV Fine 6 Fine UV Control		0

DMX TRAITS

Dim. 1CH	RGB 3CH	Col 6CH	Col & Dim 9CH	CMY 13CH	CMY Ext 16CH	Std. 16CH	Ext. 22CH	2 Cell Std 22CH	2 Cell Ext 34CH	6 Cell Std 46CH	6 Cell Ext 82CH	Raw 6 Cell 36CH	DMX Values	Function	Snap	Default Value
				4	4								0-255	Cyan Cyan Saturation 0 → 100%		0
					5								0-255	Cyan Fine Fine Cyan Control		0
				5	6								0-255	Magenta Magenta Saturation 0 → 100%		0
					7								0-255	Magenta Fine Fine Magenta Control		0
				6	8								0-255	Yellow Yellow Saturation 0 → 100%		0
					9								0-255	Yellow Fine Fine Yellow Control		0
				7	10	10	16	16	28	40	76			Variable CCT		
													0-23	Open		
													24-85	2400K → 8500K (See Sheet)		0
													86-255	8500K		
				8	11	11	17	17	29	41	77			Color Wheel		
													0	Open		
													1-179	Virtual Swatch Book (See Table)		
														Color Scroll		
													180-201	Clockwise Fast → Slow		
													202-207	Stop		
													208-229	Counter-clockwise Slow → Fast		0
													230-234	Open		
														Random Slots		
													235-239	Fast		
													240-244	Medium		
													245-249	Slow		
													250-255	Open		
				9	12	12	18	18	30	42	78		0-255	Effect Selection FX Selection 1 → 255	X	0
				10	13	13	19	19	31	43	79			Effect Speed		
													0-126	Slow → Fast		0
													127-128	Stop		
													129-255	Rev Fast → Slow		
				11	14	14	20	20	32	44	80			Effect Offset		
													0	Idle		
													1	Fixture Offset 10 Degrees		
													2	Fixture Offset 20 Degrees		
													3-34	Fixture Offset...		
													35	Fixture Offset 350 Degrees		
													36	Synchronized		
													37-49	Random Fixture Offset		
													50-59	Random Pixel Order		
													60-69	Random Steps		
													70-79	Idle	X	0
														Effect Fade		
													80-89	Sinewave- Cross		
													90-99	Sinewave- Full		
													100-109	Sawtooth- Cross		
													110-119	Sawtooth- Full		
													120-129	Ramp Up		
													130-139	Ramp Down		
													140-149	Steps		
													150-255	Idle		

DMX TRAITS

Dim. 1CH	RGB 3CH	Col 6CH	Col & Dim 9CH	CMY 13CH	CMY Ext 16CH	Std. 16CH	Ext. 22CH	2 Cell Std 22CH	2 Cell Ext 34CH	6 Cell Std 46CH	6 Cell Ext 82CH	Raw 6 Cell 36CH	DMX Values	Function	Snap	Default Value
														Dim Modes		
													0-20	Standard		
													21-40	Stage		
													41-60	TV		
													61-80	Architectural		
													81-100	Theatre		
													101-120	Stage 2		
														Dimmer Delay Time		
													121	0s		
													122	0.1s		
													123	0.2s		
													124	0.3s		
													125	0.4s		
													126	0.5s		
													127	0.6s		
													128	0.7s		
				12	15	15	21	21	33	45	81		129	0.8s	X	0
													130	0.9s		
													131	1.0s		
													132	1.5s		
													133	2.0s		
													134	3.0s		
													135	4.0s		
													136	5.0s		
													137	6.0s		
													138	7.0s		
													139	8.0s		
													140	9.0s		
													141	10s		
													142-149	Idle		
														Dim to Warm		
													150-154	DTW On		
													155-159	DTW Off		
													160-255	Idle		
														Control		
													0-59	Idle		
													60-69	Flip Pixel Order		
													70-79	Default Pixel Order		
													80-99	Idle		
														Refresh Rate (Hz)		
													100	900		
													101	910		
													102	920		
													103	930		
													104	940		
				13	16	16	22	22	34	46	82		105	950	X	0
													106	960		
													107	970		
													108	980		
													109	990		
													110	1000		
													111	1010		
													112	1020		
													113	1030		
													114	1040		
													115	1050		

DMX TRAITS

Dim. 1CH	RGB 3CH	Col 6CH	Col & Dim 9CH	CMY 13CH	CMY Ext 16CH	Std. 16CH	Ext. 22CH	2 Cell Std 22CH	2 Cell Ext 34CH	6 Cell Std 46CH	6 Cell Ext 82CH	Raw 6 Cell 36CH	DMX Values	Function	Snap	Default Value
													116	1060		
													117	1070		
													118	1080		
													119	1090		
													120	1100		
													121	1110		
													122	1120		
													123	1130		
													124	1140		
													125	1150		
													126	1160		
													127	1170		
													128	1180		
													129	1190		
													130	1200		
													131	1210		
													132	1220		
													133	1230		
													134	1240		
													135	1250		
													136	1260		
													137	1270		
													138	1280		
													139	1290		
													140	1300		
													141	1310		
													142	1320		
													143	1330		
													144	1340		
				13	16	16	22	22	34	46	82		145	1350	X	0
													146	1360		
													147	1370		
													148	1380		
													149	1390		
													150	1400		
													151	1410		
													152	1420		
													153	1430		
													154	1440		
													155	1450		
													156	1460		
													157	1470		
													158	1480		
													159	1490		
													160	1500		
													161	2500		
													162	4000		
													163	5000		
													164	6000		
													165	10000		
													166	15000		
													167	20000		
													168	25000		
													169-200	Idle		
														Dimmer Curves		
													201-210	Dimmer Curve: Linear (Default)		
													211-220	Dimmer Curve: Square		
													221-230	Dimmer Curve: Inverse Square		
													231-240	Dimmer Curve: S-Curve		
													241-255	Idle		

EMULATION DMX TRAITS FOR SIXBAR 500

6CH	7CH	11CH	13CH	36CH	DMX Values	Function	Snap	Default Value
1	1	1	1	1	0-255	Red Red Saturation 0 → 100%		0
2	2	2	2	2	0-255	Green Green Saturation 0 → 100%		0
3	3	3	3	3	0-255	Blue Blue Saturation 0 → 100%		0
4	4	4	4	4	0-255	White White Saturation 0 → 100%		0
5	5	5	5	5	0-255	Amber Amber Saturation 0 → 100%		0
6	6	6	6	6	0-255	UV UV Saturation 0 → 100%		0
				7	0-255	Red 2 Red Saturation 0 → 100%		0
				8	0-255	Green 2 Green Saturation 0 → 100%		0
				9	0-255	Blue 2 Blue Saturation 0 → 100%		0
				10	0-255	White 2 White Saturation 0 → 100%		0
				11	0-255	Amber 2 Amber Saturation 0 → 100%		0
				12	0-255	UV 2 UV Saturation 0 → 100%		0
				13	0-255	Red 3 Red Saturation 0 → 100%		0
				14	0-255	Green 3 Green Saturation 0 → 100%		0
				15	0-255	Blue 3 Blue Saturation 0 → 100%		0
				16	0-255	White 3 White Saturation 0 → 100%		0
				17	0-255	Amber 3 Amber Saturation 0 → 100%		0
				18	0-255	UV 3 UV Saturation 0 → 100%		0
				19	0-255	Red 4 Red Saturation 0 → 100%		0
				20	0-255	Green 4 Green Saturation 0 → 100%		0
				21	0-255	Blue 4 Blue Saturation 0 → 100%		0
				22	0-255	White 4 White Saturation 0 → 100%		0
				23	0-255	Amber 4 Amber Saturation 0 → 100%		0
				24	0-255	UV 4 UV Saturation 0 → 100%		0

EMULATION DMX TRAITS FOR SIXBAR 500

6CH	7CH	11CH	13CH	36CH	DMX Values	Function	Snap	Default Value
				25	0-255	Red 5 Red Saturation 0 → 100%		0
				26	0-255	Green 5 Green Saturation 0 → 100%		0
				27	0-255	Blue 5 Blue Saturation 0 → 100%		0
				28	0-255	White 5 White Saturation 0 → 100%		0
				29	0-255	Amber 5 Amber Saturation 0 → 100%		0
				30	0-255	UV 5 UV Saturation 0 → 100%		0
				31	0-255	Red 6 Red Saturation 0 → 100%		0
				32	0-255	Green 6 Green Saturation 0 → 100%		0
				33	0-255	Blue 6 Blue Saturation 0 → 100%		0
				34	0-255	White 6 White Saturation 0 → 100%		0
				35	0-255	Amber 6 Amber Saturation 0 → 100%		0
				36	0-255	UV 6 UV Saturation 0 → 100%		0
	7	7	7		0-255	Dimmer Intensity 0 → 100%		0
		8	8			Shutter/Strobe		
					0-31	Shutter closed		
					32-63	No function (shutter open)		
					64-95	Strobe effect slow to fast		
					96-127	No function (shutter open)		
					128-159	Pulse-effect in sequences	X	50
					160-191	No function (shutter open)		
					192-223	Random strobe effect slow to fast		
					224-255	No function (shutter open)		
			9			Color Macros		
					0-3	OFF		
					4-7	RED		
					8-11	GREEN		
					12-15	BLUE		
					16-19	WHITE		
					20-23	AMBER		
					24-27	UV		
					28-31	RED + GREEN		
					32-35	RED + BLUE		
					36-39	RED + WHITE		
					40-43	RED + AMBER		
					44-47	RED + UV		
					48-51	GREEN + BLUE		
					52-55	GREEN + WHITE		
					56-59	GREEN + AMBER		
					60-63	GREEN + UV		
					64-67	BLUE + WHITE		
					68-71	BLUE + AMBER		
					72-75	BLUE + UV		
					76-79	WHITE + AMBER		
					80-83	WHITE + UV		
					84-87	AMBER + UV		
					88-91	RED + GREEN + BLUE		
					92-95	RED + GREEN + WHITE		
					96-99	RED + GREEN + AMBER		
					100-103	RED + GREEN + UV		
					104-107	RED + BLUE + WHITE		
					108-111	RED + BLUE + AMBER		
					112-115	RED + BLUE + UV		
					116-119	RED + WHITE + AMBER		
					120-123	RED + WHITE + UV		
							X	0

EMULATION DMX TRAITS FOR SIXBAR 500

6CH	7CH	11CH	13CH	36CH	DMX Values	Function	Snap	Default Value
						Color Macros		
					124-127	RED + AMBER + UV		
					128-131	GREEN + BLUE + WHITE		
					132-135	GREEN + BLUE + AMBER		
					136-139	GREEN + BLUE + UV		
					140-143	GREEN + WHITE + AMBER		
					144-147	GREEN + WHITE + UV		
					148-151	GREEN + AMBER + UV		
					152-155	BLUE + WHITE + AMBER		
					156-159	BLUE + WHITE + UV		
					160-163	BLUE + AMBER + UV		
					164-167	WHITE + AMBER + UV		
					168-171	RED + GREEN + BLUE + WHITE		
					172-175	RED + GREEN + BLUE + AMBER		
					176-179	RED + GREEN + BLUE + UV		
					180-183	RED + GREEN + WHITE + AMBER		
			9		184-187	RED + GREEN + WHITE + UV	X	0
					188-191	RED + GREEN + AMBER + UV		
					192-195	RED + BLUE + WHITE + AMBER		
					196-199	RED + BLUE + WHITE + UV		
					200-203	RED + BLUE + AMBER + UV		
					204-207	RED + WHITE + AMBER + UV		
					208-211	GREEN + BLUE + WHITE + AMBER		
					212-215	GREEN + BLUE + WHITE + UV		
					216-219	GREEN + BLUE + AMBER + UV		
					220-223	GREEN + WHITE + AMBER + UV		
					224-227	BLUE + WHITE + AMBER + UV		
					228-231	RED + GREEN + BLUE + WHITE + AMBER		
					232-235	RED + GREEN + BLUE + WHITE + UV		
					236-239	RED + GREEN + BLUE + AMBER + UV		
					240-243	RED + GREEN + WHITE + AMBER + UV		
					244-247	RED + BLUE + WHITE + AMBER + UV		
					248-251	GREEN + BLUE + WHITE + AMBER + UV		
					252-255	RED + GREEN + BLUE + WHITE + AMBER + UV		
						Program Macros		
					0-10	No Function		
					11-26	Program 01 - Dream		
					27-43	Program 02 - Meteor		
					44-60	Program 03 - Fade		
					61-76	Program 04 - Change		
					77-93	Program 05 - Flow 1		
					94-110	Program 06 - Flow 2		
					111-126	Program 07 - Flow 3		
					127-143	Program 08 - Flow 4		
					144-160	Program 09 - Flow 5		
					161-176	Program 10 - Flow 6		
					177-193	Program 11 - Flow 7		
					194-210	Program 12 - Flow 8		
					211-226	Program 13 - Flow 9		
					227-255	No Function		
						Program Speed		
					0-255	Slow → Fast		0
						Program Fade		
					0-255	Slow → Fast		0
						Dimming Modes		
					0-20	Standard		
					21-40	Stage		
					41-60	TV		
					61-80	Architectural		
					81-100	Theatre		
					101-255	No Function	X	0

PIXEL GROUPING & FLIP DIAGRAM

Pixel Grouping



Flip Diagram



COLOR TEMPERATURE

DMX VALUE	COLOR TEMPERATURE (K)	DMX VALUE	COLOR TEMPERATURE (K)
24	2400	63	6300
25	2500	64	6400
26	2600	65	6500
27	2700	66	6600
28	2800	67	6700
29	2900	68	6800
30	3000	69	6900
31	3100	70	7000
32	3200	71	7100
33	3300	72	7200
34	3400	73	7300
35	3500	74	7400
36	3600	75	7500
37	3700	76	7600
38	3800	77	7700
39	3900	78	7800
40	4000	79	7900
41	4100	80	8000
42	4200	81	8100
43	4300	82	8200
44	4400	83	8300
45	4500	84	8400
46	4600	85	8500
47	4700		
48	4800		
49	4900		
50	5000		
51	5100		
52	5200		
53	5300		
54	5400		
55	5500		
56	5600		
57	5700		
58	5800		
59	5900		
60	6000		
61	6100		
62	6200		

VIRTUAL COLORS

VALUE	FILTER #	COLOR	VALUE	FILTER #	COLOR
1	7	Pale Yellow	31	126	Mauve
2	103	Straw	32	49	Medium Purple
3	151	Gold Tint	33	58	Lavender
4	100	Spring Yellow	34	199	Palace Blue
5	10	Medium Yellow	35	119	Dark Blue
6	101	Yellow	36	132	Medium Blue
7	104	Deep Amber	37	120	Deep Blue
8	15	Deep Straw	38	165	Daylight Blue
9	179	Loving Amber	39	161	Slate Blue
10	21	Gold Amber	40	118	Light Blue
11	105	Orange	41	68	Sky Blue
12	158	Deep Orange	42	143	Pale Navy Blue
13	22	Dark Amber	43	131	Marine Blue
14	778	Millennium Gold	44	115	Peacock Blue
15	135	Deep Golden Amber	45	172	Lagoon Blue
16	24	Scarlet	46	116	Medium Blue Green
17	106	Primary Red	47	90	Dark Yellow Green
18	26	Bright Red	48	139	Primary Green
19	27	Medium Red	49	122	Fern Green
20	19	Fire	50	89	Moss Green
21	157	Pink	51	124	Dark Green
22	36	Medium Pink	52	88	Lime Green
23	111	Dark Pink	53	138	Pale Green
24	128	Bright Pink	54	203	Quarter CT Blue
25	148	Bright Rose	55	202	Half CT Blue
26	332	Special Rose Pink	56	201	FULL CT Blue
27	793	Vanity Fair	57	200	Double CT Blue
28	113	Magenta	58	206	Quarter CT Orange
29	46	Dark Magenta	59	205	Half CT Orange
30	48	Rose Purple	60	204	FULL CT Orange

ERROR CODES

Error Codes subject to change without notice	
ERROR CODES	DESCRIPTION
Temp Error	This message appears when there is a heating error.

MAINTENANCE GUIDELINES



DISCONNECT POWER BEFORE PERFORMING ANY MAINTENANCE!

CLEANING

Frequent cleaning is recommended to ensure proper function, optimized light output, and an extended life. The frequency of cleaning depends on the environment in which the fixture operates: damp, smoky or particularly dirty environments can cause greater accumulation of dirt on the fixture's optics. Clean periodically with a soft cloth to avoid dirt/debris accumulation.

NEVER use alcohol, solvents, or ammonia-based cleaners.

MAINTENANCE

Regular inspections are recommended to insure proper function and extended life. There are no user serviceable parts inside this fixture. Please refer all other service issues to an authorized Elation service technician. Should you need any spare parts, please order genuine parts from an authorized Elation dealer.

Please refer to the following points during routine inspections:

- A detailed electrical check by an approved electrical engineer every three months, to make sure the circuit contacts are in good condition and prevent overheating.
- Be sure all screws and fasteners are securely tightened at all times. Loose screws may fall out during normal operation, resulting in damage or injury as larger parts could fall.
- Check for any deformations on the housing, color lenses, rigging hardware and rigging points (ceiling, suspension, trussing). Deformations in the housing could allow for dust to enter into the fixture. Damaged rigging points or unsecured rigging could cause the fixture to fall and seriously injure a person(s).
- Electric power supply cables must not show any damage, material fatigue or sediments.

SPECIFICATIONS

SOURCE

(6) x 20W RGBLA+ UV LEDs
30,000 Hour Average LED Life*

*May vary depending on several factors including but not limited to: Environmental Conditions, Power/Voltage, Usage Patterns (On-Off Cycling), Control and Dimming.

PHOTOMETRIC DATA

Total Lumen Output:
4,435 (Goniometer)
CRI- 90.9
TLCI- 80

No Lens

Beam Angle: 20°
Field Angle: 33°

Included Frost

Beam Angle: 30°
Field Angle: 60°

EFFECTS

Full Pixel Control
Electronic Dimmer and Strobe
Variable 16-bit Dimming Modes and Curves

COLOR

RGBLA+ UV Color Array
CMY Emulation
Variable CCT 2400K - 8500K
Dim-to-Warm Fade
Virtual Gel Swatch Book

CONTROL / CONNECTIONS

13 DMX Channel Modes (1ch, 3ch, 6ch, 9ch, 13ch, 16ch, 22ch, 22ch, 34ch, 46ch, 82ch, 36ch)
5 Six Bar 500 Emulation DMX Channel Modes (6ch, 7ch, 11ch, 13ch, 36ch)
4 Button Control Panel, LED Display
DMX, RDM, Art-NET, sACN Protocol Support
Aria x2 Wireless Device Management
RDM (Remote Device Management)
IP65 RJ45 Ethernet In/Out (Art-Net, sACN, KlingNet)
IP65 5pin XLR DMX In/Out
IP65 Locking Power Cable In/Out

SIZE / WEIGHT

Length: 19.7" (501mm)
Width: 6.9" (176mm)
Vertical Height: 8.1" (206mm)
Weight: 14.88 lbs / 6.75kg

ELECTRICAL / THERMAL

AC 100-240V - 50/60Hz
110W Max Power Consumption
Power Thru Capacity: 10A (10 units @110V;
21 units @240V)
5°F to 113°F (-15°C to 45°C)
BTU/hr (+/- 10%) 375.1

INCLUDED ITEMS

Safety Cable
IP65 Locking Power Cable
Frost Filter
Glare Shield
Fixture Interconnect Splice

OPTIONAL ITEMS

BAR S NSP Lens (BLS021)
BAR S WFL Lens (BLS061)
BAR S XFL Lens (BLS101)
BAR S L140 Lens (BLS141)
BAR S L1060 Lens (BLS161)
BAR S Dome Frost Lens (BLS181)
BAR S Black Lens (BLS125)
8050000053 - Omega Bracket (Qty.2)
Fixture Interconnect Splice Package (FISP06)
L-Track to M10 Adapter, 70mm (LTR001)
L-Track to M10 Adapter, 44.5mm (LTR008)
L Track C-Clamp & Adapter Assembly, 70mm (LTR100)
L Track C-Clamp & Adapter Assembly, 44.5mm (LTR112)
Interconnect Clamp Adapter (FICA01)

APPROVALS / RATINGS

CE | cETLus | IP65 | FCC | UKCA

Specifications and documentation subject to change without notice.

DIMENSIONAL DRAWINGS

Drawings not to scale

INTERCONNECT CLAMP ADAPTOR

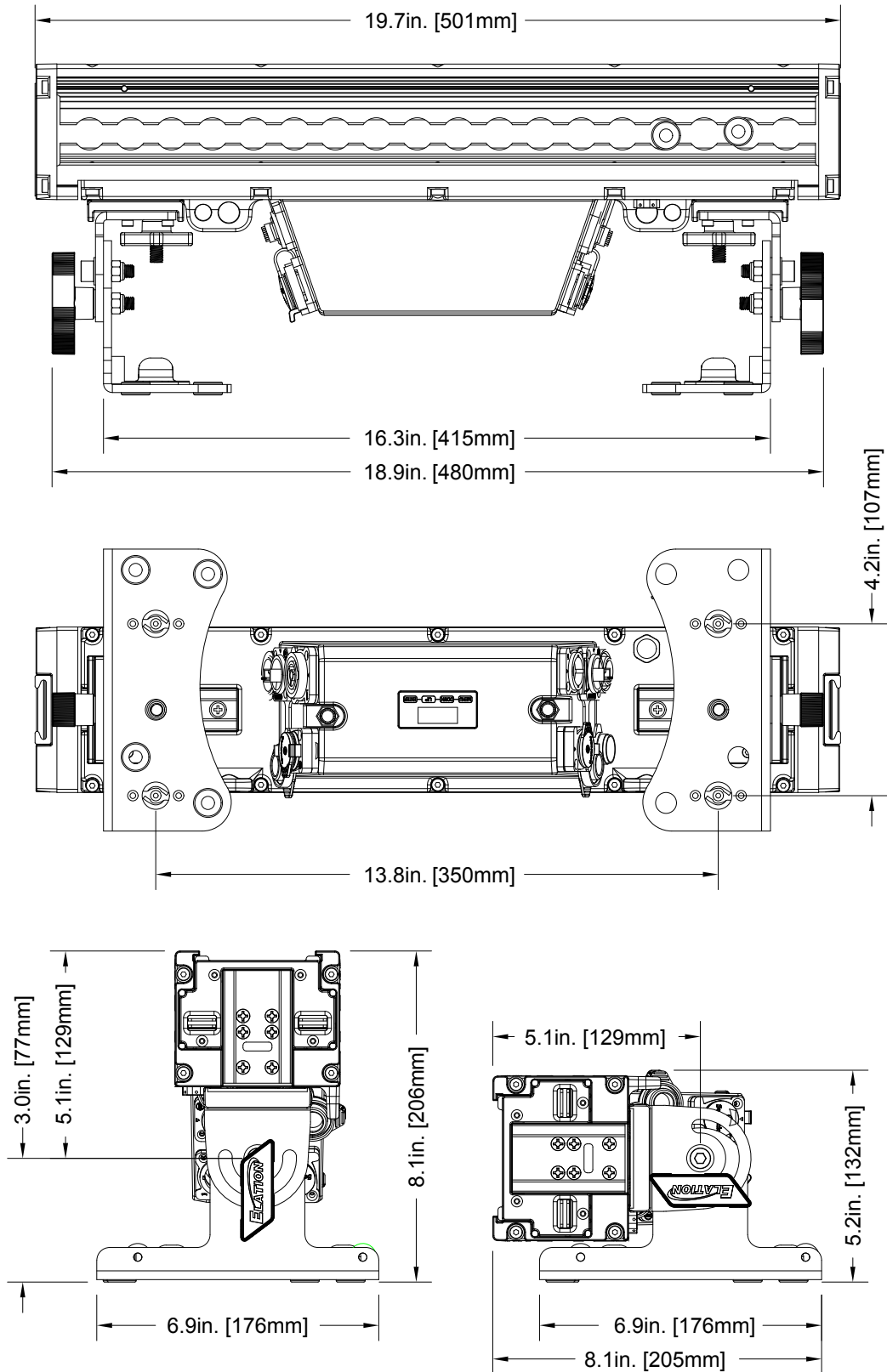

DIMENSIONAL DRAWINGS

Drawings not to scale

INTERCONNECT CLAMP ADAPTOR

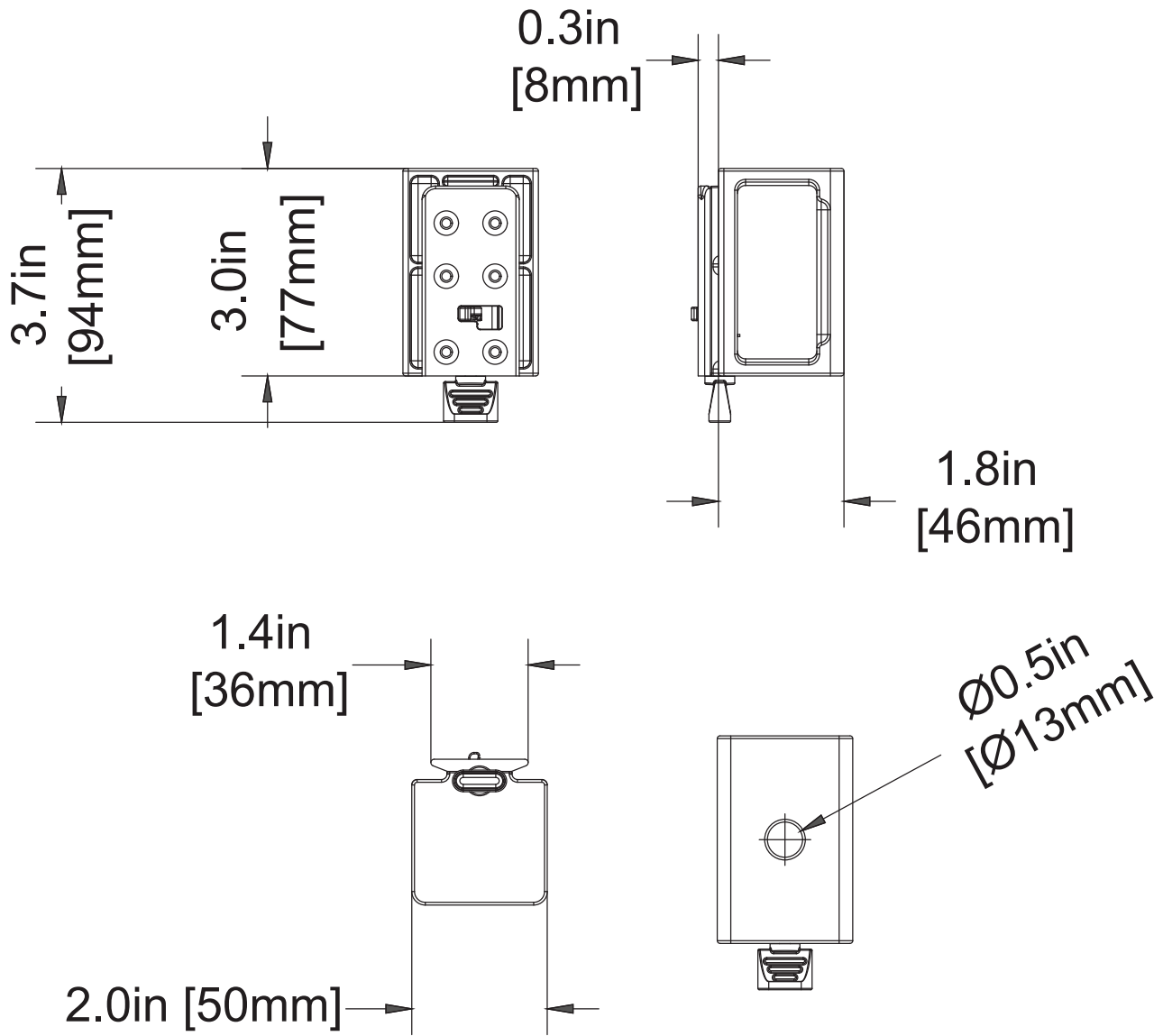

ORDERING INFORMATION

SKU US/EU		ITEM DESCRIPTION
SIX226	1237000341	SIX+ BAR S
BLS061	1223200108	BAR S WFL
BLS021	1223200117	BAR S NSP
BLS101	1223200116	BAR S XFL
BLS141	1223200115	BAR S L140
BLS161	1223200114	BAR S L1060
BLS181	PENDING	BAR S Dome Frost Lens
BLS125	PENDING	BAR S Black Lens
SPHDY	1236300112	SÖL/PULSE HD YOKE
FISP06	1236300110	Fixture Interconnect Splice Package
LTR001	1744000021	L-Track to M10 Adapter, 70mm
LTR008	1744000022	L-Track to M10 Adapter, 44.5mm
LTR100	1744000023	L-Track C-Clamp & Adapter Assembly, 70mm
LTR112	1744000025	L-Track C-Clamp & Adapter Assembly, 44.5mm
TRIGGER CLAMP	1741000032	Heavy Duty Wrap Around Hook Style Clamp
STR527	N/A	5 ft. (1.5m) IP65 5pin XLR Cable



FCC STATEMENT

This device complies with Part 15 of the FCC Rules. Operation is subject to the following two conditions: (1) this device may not cause harmful interference, and (2) this device must accept any interference received, including interference that may cause undesired operation.

FCC RADIO FREQUENCY INTERFERENCE WARNINGS & INSTRUCTIONS

This product has been tested and found to comply with the limits as per Part 15 of the FCC Rules. These limits are designed to provide reasonable protection against harmful interference in a residential installation. This device uses and can radiate radio frequency energy and, if not installed and used in accordance with the included instructions, may cause harmful interference to radio communications. However, there is no guarantee that interference will not occur in a particular installation. If this device does cause harmful interference to radio or television reception, which can be determined by turning the device off and on, the user is encouraged to try to correct the interference by one or more of the following methods:

- Reorient or relocate the device.
- Increase the separation between the device and the receiver.
- Connect the device to an electrical outlet on a circuit different from which the radio receiver is connected.
- Consult the dealer or an experienced radio/TV technician for help.

Energy Saving Matters (EuP 2009/125/EC)

Saving electric energy is a key to help protecting the environment. Please turn off all electrical products when they are not in use. To avoid power consumption in idle mode, disconnect all electrical equipment from power when not in use. Thank you!

INDEX

- Accessory installation, 19–20
- Air valve, 8, 10
- Aria channel, 26
- Aria setup, 21–23
- Art-Net, 26, 43

- Beam angle, 43
- Box contents, 4
- BTU/hr, 43

- Calibration, 27
- CCT, 26, 32, 39, 43
- CMY emulation, 26, 27, 32, 43
- Color temperature, 39
- Color wheel, 32, 40
- Control panel, 25, 43
- CRI, 43
- Customer support, 4, 25

- De-humidification, 10
- Dimensional drawings, 44
- Dimmer curves, 26, 28
- Dimmer modes, 26, 28
- Dimmer speed, 26
- Dim-to-warm, 26, 43
- Display settings, 25–26
- DMX address, 24, 26
- DMX channel modes, 24, 26, 29–35, 43
- DMX traits, 29–34

- Electrical specifications, 43
- Error codes, 27, 41
- Ethernet, 26, 43

- FCC statement, 46
- Field angle, 43
- Fixture interconnect splice, 4, 8, 9, 15, 43, 46
- Frost filter, 4, 19, 43, 46

- Glare shield, 4, 20, 43

- Humidity, 5, 10, 27

- IP65 rating, 5, 10, 17, 43
- IP test parameters, 10

- KlingNet, 26, 43

- LED power limit, 26
- LED refresh rate, 26
- Lime, 26, 29–32
- L-track mounting, 8, 9, 13, 16, 46

- Maintenance, 5, 42
- Manual control, 26
- Maritime installations, 5
- Mounting clamps, 12, 46

- No DMX status, 22, 26

- Omega brackets, 12, 46
- Operating temperature, 6, 11, 43
- Optional items, 43, 46
- Ordering information, 46

- Pixel flip, 26, 38
- Pixel grouping, 38
- Power connections, 8, 17, 43
- Power thru capacity, 43

- RDM, 24, 43
- Rigging limits, 13, 16

- sACN, 26, 43
- Safety cable, 4, 8, 12, 14, 16, 43
- Safety guidelines, 6–7
- Screen lock, 25–26
- Service menu, 27
- Shutter/strobe, 29, 43
- SixBar 500 emulation, 26–27, 35–37
- Specifications, 43
- Sub-GHz frequencies, 21
- System menu, 25–27

- TLCI, 43
- Torque settings, 9
- Trunion bracket, 8, 9, 12–14, 16

- UV, 7, 26, 29–32

- Virtual colors, 26, 32, 40, 43

- Warranty, 4
- Wireless device management, 21–23, 43

