

ELATION[®]



Rebel Profile

Photometric &
Chromaticity Test Reports

CONTENTS

Testing Procedures	3
Photometric Output Reports	4
Zoom Wide.....	4
Zoom 50%.....	6
Zoom Narrow	8
Zoom 50%-CRI 80	10
Zoom 50%-CRI 90	12
Zoom 50%-CRI 80-CTO	14
Zoom 50%-CRI 90-CTO	16
Zoom 50%-Low Fan Mode	18
Zoom 50%-Studio Fan Mode	20
Zoom 50%-Mute Fan Mode	22
Color Quality Reports	24
Full Output.....	24
CRI 80	26
CRI 90	28
CRI 80-CTO	30
CRI 90-CTO	32
Color Reports	34
Cyan.....	34
Magenta	35
Yellow.....	36

©2026 ELATION PROFESSIONAL all rights reserved. Information, specifications, diagrams, images, and instructions herein are subject to change without notice. ELATION PROFESSIONAL logo and identifying product names and numbers herein are trademarks of ELATION PROFESSIONAL. Copyright protection claimed includes all forms and matters of copyrightable materials and information now allowed by statutory or judicial law or hereinafter granted. Product names used in this document may be trademarks or registered trademarks of their respective companies and are hereby acknowledged. All non-ELATION brands and product names are trademarks or registered trademarks of their respective companies.

Elation Professional USA | 6122 S. Eastern Ave. | Los Angeles, CA. 90040
323-582-3322 | 323-832-9142 fax | www.elationlighting.com | info@elationlighting.com

Elation Professional B.V. | Junostraat 2 | 6468 EW Kerkrade, The Netherlands
+31 45 546 85 66 | +31 45 546 85 96 fax | www.elationlighting.eu | info@elationlighting.eu

Elation Professional Mexico | AV Santa Ana 30 | Parque Industrial Lerma, Lerma, Mexico 52000 +52 (728) 282-7070

Testing Process

Total Lumen Measurements

Lumens are measured using a Viso Systems Lab Spion. As a goniophotometer, the Viso calculates the field lumens of the fixture by taking multiple measurements across the light beam.

Many lumens figures provided for entertainment lighting fixtures are only 2π sphere values, some even emphasize the LED engine lumens. All Elation product photometric data is the actual light output from the fixture lens, never a theoretical value based on calculation or using the source lumens as the fixtures output. We advise to always compare total fixture lumens acquired with identical measurement systems when comparing lighting fixtures.

Test Lab Equipment and Process

Elation operates an optical testing laboratory at its Los Angeles, CA headquarters to provide accurate photometric data for its lighting products. The testing lab is both light and climate- controlled and contains a variety of precise lighting measurement systems. Fixtures are analyzed with the sophisticated [Viso Systems Lab Spion](#) equipment, which measures all light and color parameters by panning the light beam at a precise speed and from different angles through a calibrated, laser aligned light and color sensor. Test data is collected and summarized by the Viso Light Inspector software. This type of measurement system is referred to as a Goniophotometer.

The Viso software calculates all relevant types of measurements, from beam angles, candela to center light intensity at a variety of distances to the latest color quality measurements like TM30 or CQS as well as accurate color temperature. This wealth of data is then processed by an Elation specific template which is included in the photometric test report for various fixture conditions such as zoom angles and color correction filters.

The Viso software also creates IES (Illuminating Engineering Society) files for each test report. IES is an industry standard file format created for the easy electronic transfer of photometric test data, which is widely used by lighting manufacturers for photometric data distribution.

Additionally, fixtures are periodically rechecked for accuracy using various hand-held light meters including one or more of the devices listed below. This is done to ensure the test data contained in this report is as accurate as possible.

[Asenstek Lighting Passport](#) | [Konica Minolta T-10](#) | [Sekonic C800U](#)

Key Measurements

Output

Total Lumen Output: 20570 lm

Peak Intensity: 39848 cd

Beam

Beam Angle (50%): 50.1°

Field Angle (10%): 53.4°

Cutoff Angle (2.5%): 54.2°

Color

Color Temperature: 6560 K

CRI: 70.9

TLCI: 49

TM30 R_F: 72.1

TM30 R_g: 92.5

Power Details

Efficacy: 27 Lumen/Watt

Power: 774.3 W

Supply Voltage: 230 V

Current: 3.39 A

Beam Details

Distance	3 m	5 m	10 m	15 m	20 m
Beam Width	2.8 m	4.7 m	9.3 m	14 m	18.7 m

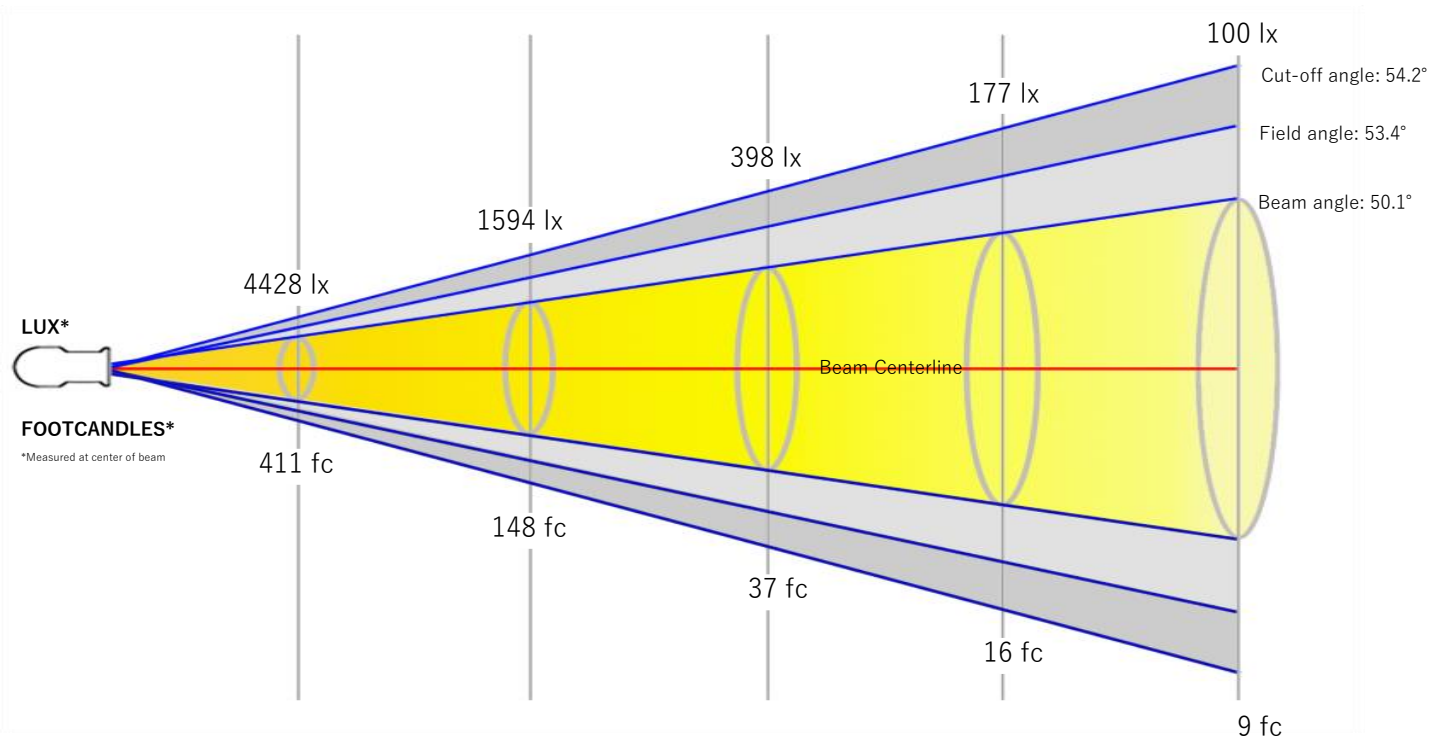

Distance	9.8 ft	16.4 ft	32.8 ft	49.2 ft	65.6 ft
Beam Width	9.2 ft	15.3 ft	30.7 ft	46 ft	61.3 ft

Beam Intensities from 1-20m

M	1	2	3	4	5	6	7	8	9	10	11	12	13	14	15	16	17	18	19	20
LX	39848	9962	4428	2491	1594	1107	813	623	492	398	329	277	236	203	177	156	138	123	110	100
FT	3.3	6.6	9.8	13.1	16.4	19.7	23	26.2	29.5	32.8	36.1	39.4	42.7	45.9	49.2	52.5	55.8	59.1	62.3	65.6
FC	3702	925.5	411.3	231.4	148.1	102.8	75.6	57.8	45.7	37	30.6	25.7	21.9	18.9	16.5	14.5	12.8	11.4	10.3	9.3

Angular Distribution

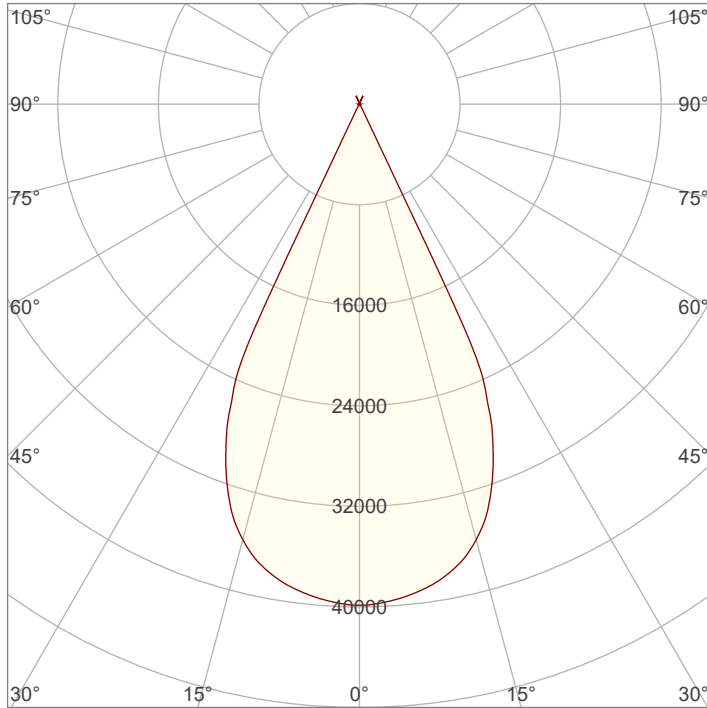

Beam Angle - 50%
50.1°
Field Angle - 10%
53.4°
Cutoff Angle - 2.5%
54.2°

ISO Diagrams

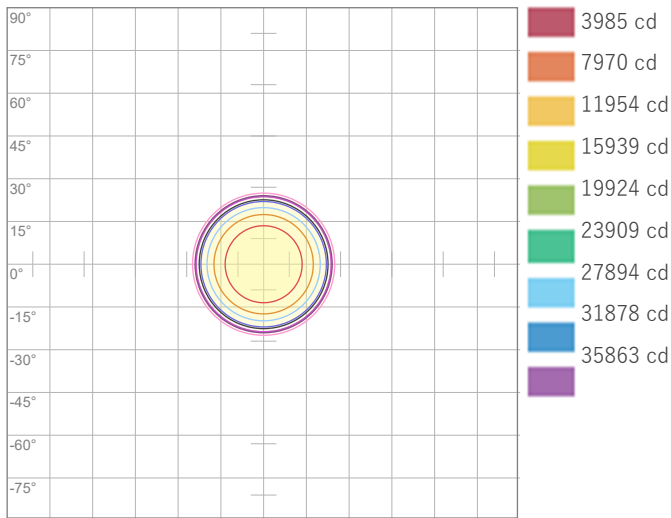

ISO Candela Diagram

Conditions:

Number of c-planes: 2

Candela at center: 39848 cd

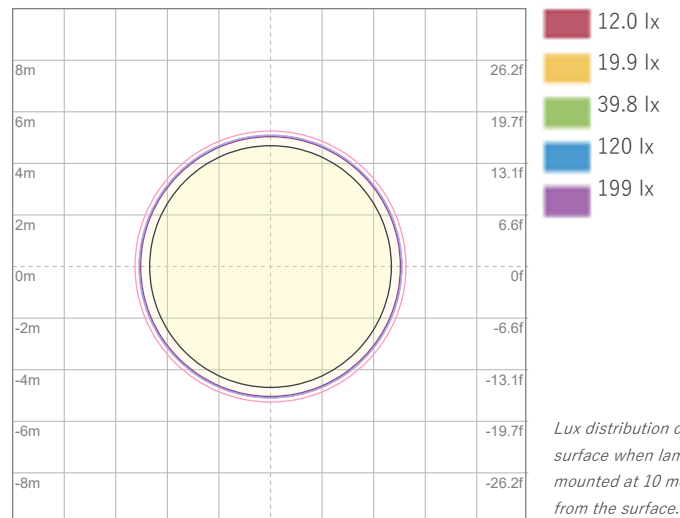

ISO LUX Diagram

Conditions:

Number of c-planes: 2

LUX at center: 398 lx

Lux distribution on a surface when lamp is mounted at 10 meters from the surface.

Linear Distribution

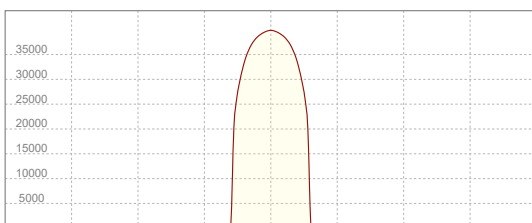

Peak Candela
39848 cd

Calculate Center Beam Intensities

$$\text{lux} = 39848 / \text{distance(m)}^2$$

$$\text{fc} = 39848 / \text{distance(ft)}^2$$

Key Measurements

Output

Total Lumen Output: 20228 lm

Peak Intensity: 321522 cd

Beam

Beam Angle (50%): 17.4°

Field Angle (10%): 19.2°

Cutoff Angle (2.5%): 19.4°

Color

Color Temperature: 6509 K

CRI: 71.0

TLCI: 49

TM30 R_F: 72.2

TM30 R_g: 92.8

Power Details

Efficacy: 26 Lumen/Watt

Power: 775.8 W

Supply Voltage: 230 V

Current: 3.39 A

Beam Details

Distance	3 m	5 m	10 m	15 m	20 m
Beam Width	0.9 m	1.5 m	3.1 m	4.6 m	6.1 m

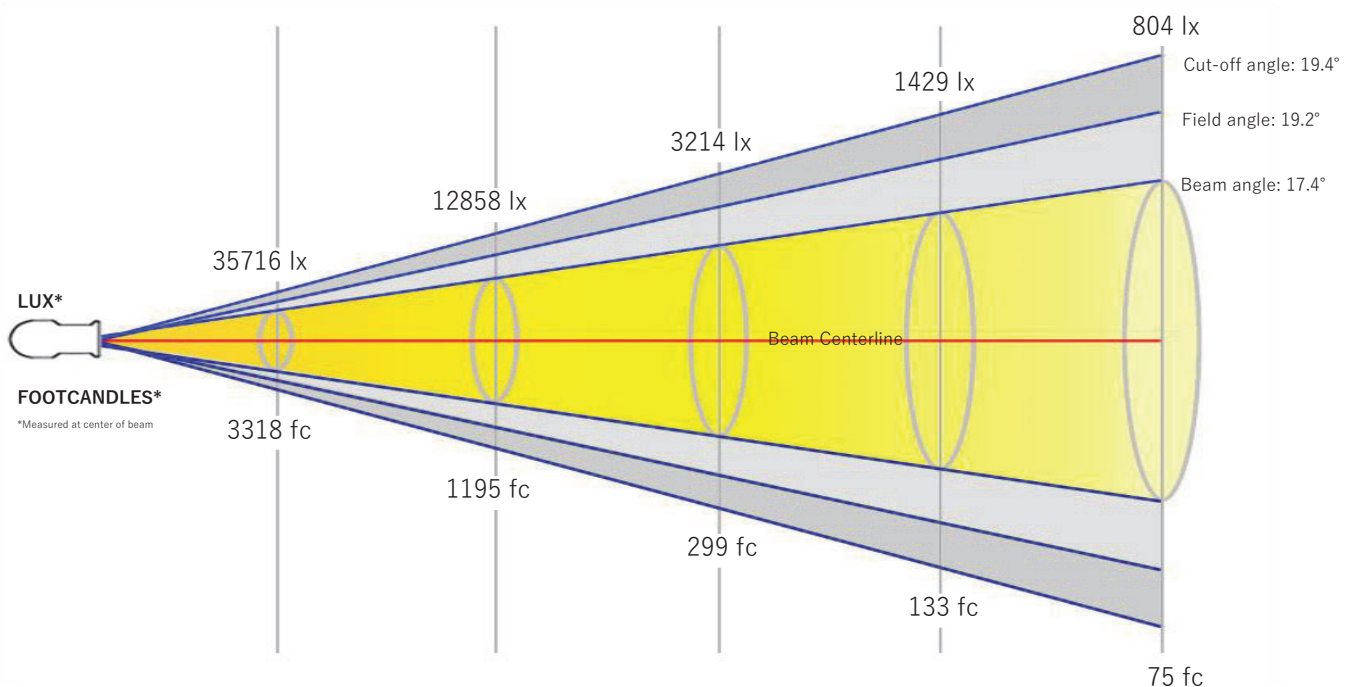

Distance	9.8 ft	16.4 ft	32.8 ft	49.2 ft	65.6 ft
Beam Width	3 ft	5 ft	10 ft	15.1 ft	20.1 ft

Beam Intensities from 1-20m

M	1	2	3	4	5	6	7	8	9	10	11	12	13	14	15	16	17	18	19	20
LX	321442	80360	35716	20090	12858	8929	6560	5023	3968	3214	2657	2232	1902	1640	1429	1256	1112	992	890	804
FT	3.3	6.6	9.8	13.1	16.4	19.7	23	26.2	29.5	32.8	36.1	39.4	42.7	45.9	49.2	52.5	55.8	59.1	62.3	65.6
FC	29862.9	7465.7	3318.1	1866.4	1194.5	829.5	609.4	466.6	368.7	298.6	246.8	207.4	176.7	152.4	132.7	116.7	103.3	92.2	82.7	74.7

Angular Distribution

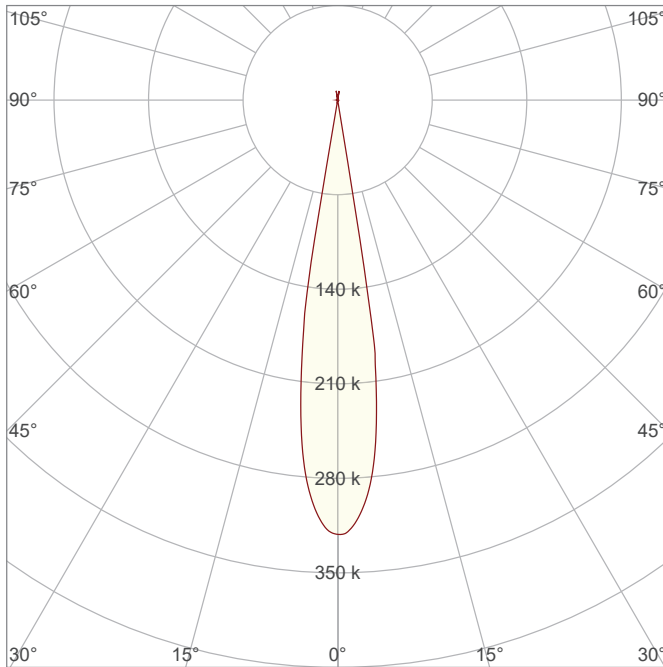

Beam Angle - 50%
17.4°
Field Angle - 10%
19.2°
Cutoff Angle - 2.5%
19.4°

ISO Diagrams

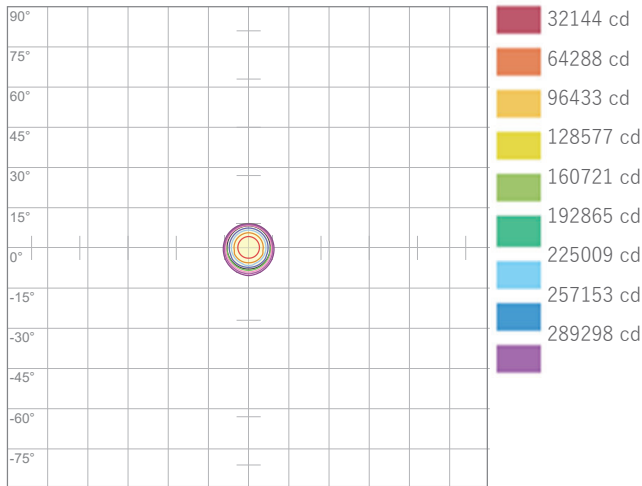

ISO Candela Diagram

Conditions:
Number of c-planes: 2
Candela at center: 321442 cd

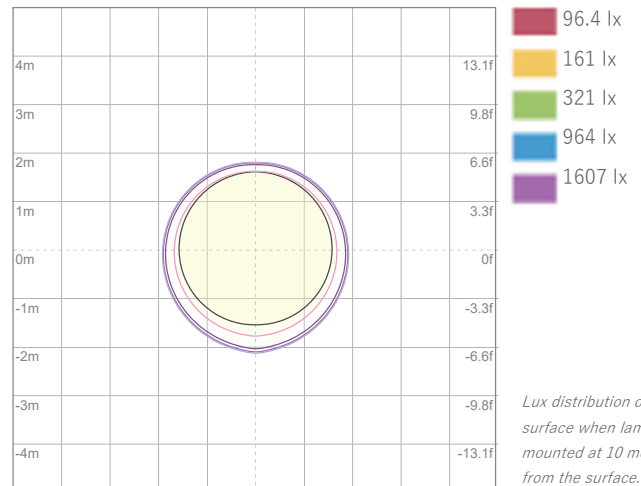

ISO LUX Diagram

Conditions:
Number of c-planes: 2
LUX at center: 3214 lx

Lux distribution on a surface when lamp is mounted at 10 meters from the surface.

Linear Distribution

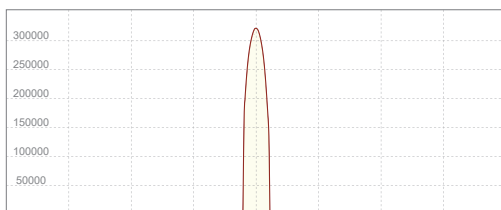

Peak Candela
321522 cd

Calculate Center Beam Intensities

$$\text{lux} = 321522 / \text{distance(m)}^2$$

$$\text{fc} = 321522 / \text{distance(ft)}^2$$

Key Measurements

Output

Total Lumen Output: 9139 lm

Peak Intensity: 3218110 cd

Beam

Beam Angle (50%): 3.6°

Field Angle (10%): 3.9°

Cutoff Angle (2.5%): 4°

Color

Color Temperature: 6620 K

CRI: 71.7

TLCI: 49

TM30 R_F: 72.2

TM30 R_g: 93.3

Power Details

Efficacy: 12 Lumen/Watt

Power: 779.1 W

Supply Voltage: 230 V

Current: 3.40 A

Beam Details

Distance	3 m	5 m	10 m	15 m	20 m
Beam Width	0.2 m	0.3 m	0.6 m	0.9 m	1.2 m

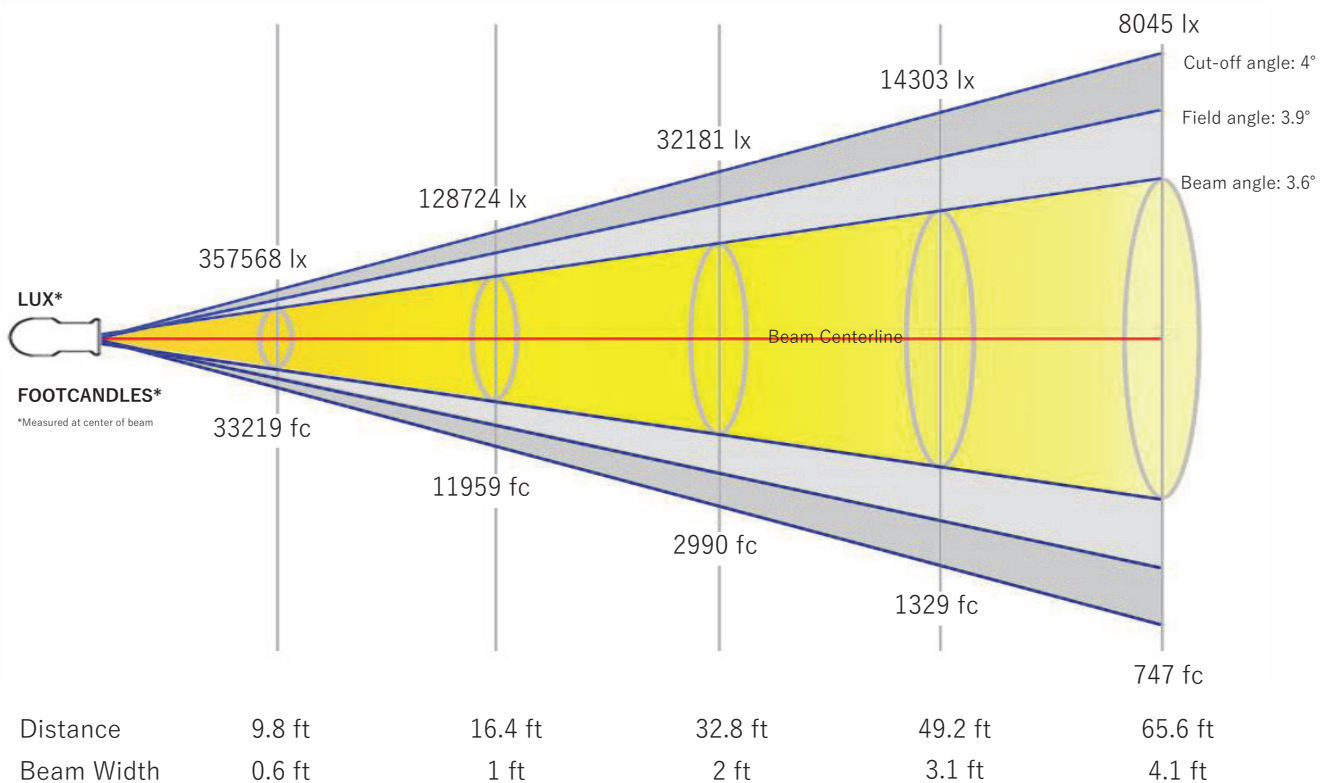

Beam Intensities from 1-20m

M	1	2	3	4	5	6	7	8	9	10	11	12	13	14	15	16	17	18	19	20
LX	3218109	804527	357568	201132	128724	89392	65676	50283	39730	32181	26596	22348	19042	16419	14303	12571	11135	9932	8914	8045
FT	3.3	6.6	9.8	13.1	16.4	19.7	23	26.2	29.5	32.8	36.1	39.4	42.7	45.9	49.2	52.5	55.8	59.1	62.3	65.6
FC	298972.2	74743	33219.1	18685.8	11958.9	8304.8	6101.5	4671.4	3691	2989.7	2470.8	2076.2	1769.1	1525.4	1328.8	1167.9	1034.5	922.8	828.2	747.4

Angular Distribution

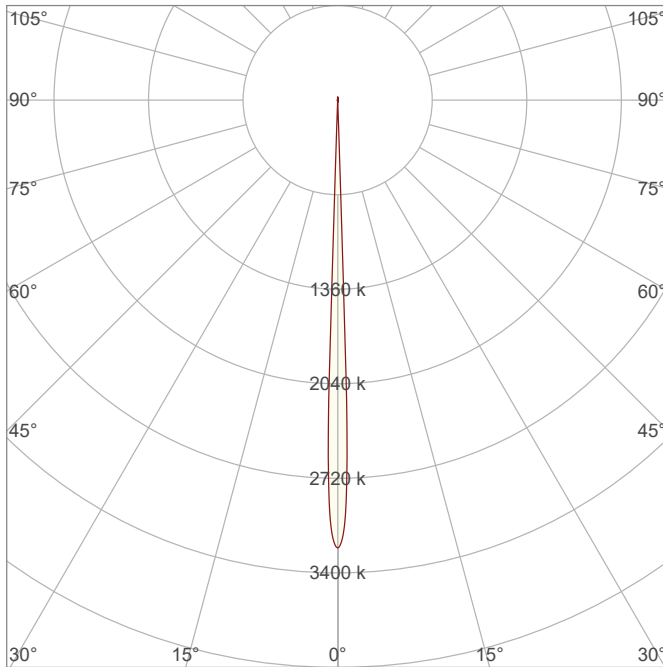

Beam Angle - 50%
3.6°
Field Angle - 10%
3.9°
Cutoff Angle - 2.5%
4°

ISO Diagrams

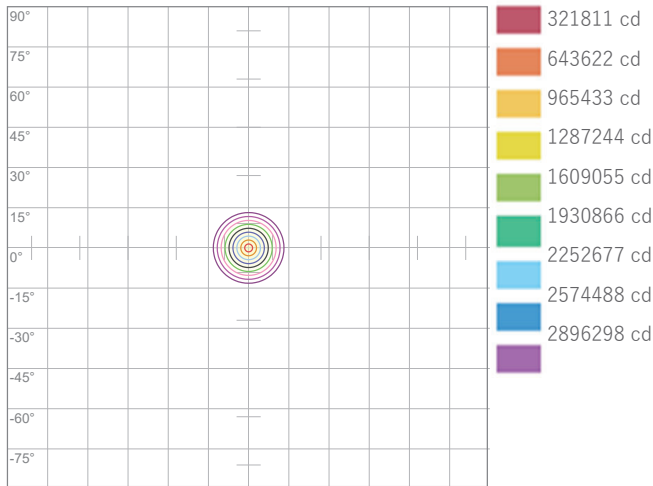

ISO Candela Diagram

Conditions:
Number of c-planes: 2
Candela at center: 3218109 cd

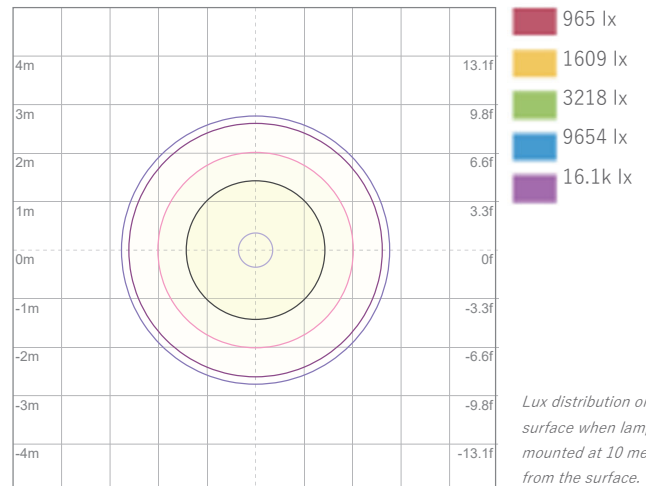

ISO LUX Diagram

Conditions:
Number of c-planes: 2
LUX at center: 32.2k lx

Lux distribution on a surface when lamp is mounted at 10 meters from the surface.

Linear Distribution

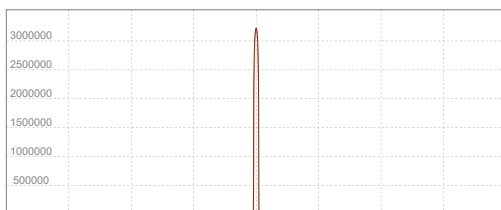

Peak Candela
3218110 cd

Calculate Center Beam Intensities

$$\text{lux} = 3218110 / \text{distance(m)}^2$$

$$\text{fc} = 3218110 / \text{distance(ft)}^2$$

Key Measurements

Output

Total Lumen Output: 14396 lm

Peak Intensity: 227439 cd

Beam

Beam Angle (50%): 17.5°

Field Angle (10%): 19.2°

Cutoff Angle (2.5%): 19.4°

Color

Color Temperature: 6625 K

CRI: 88.0

TLCI: 78

TM30 R_F: 83.9

TM30 R_g: 100.7

Power Details

Efficacy: 19 Lumen/Watt

Power: 775.3 W

Supply Voltage: 230 V

Current: 3.39 A

Beam Details

Distance	3 m	5 m	10 m	15 m	20 m
Beam Width	0.9 m	1.5 m	3.1 m	4.6 m	6.2 m

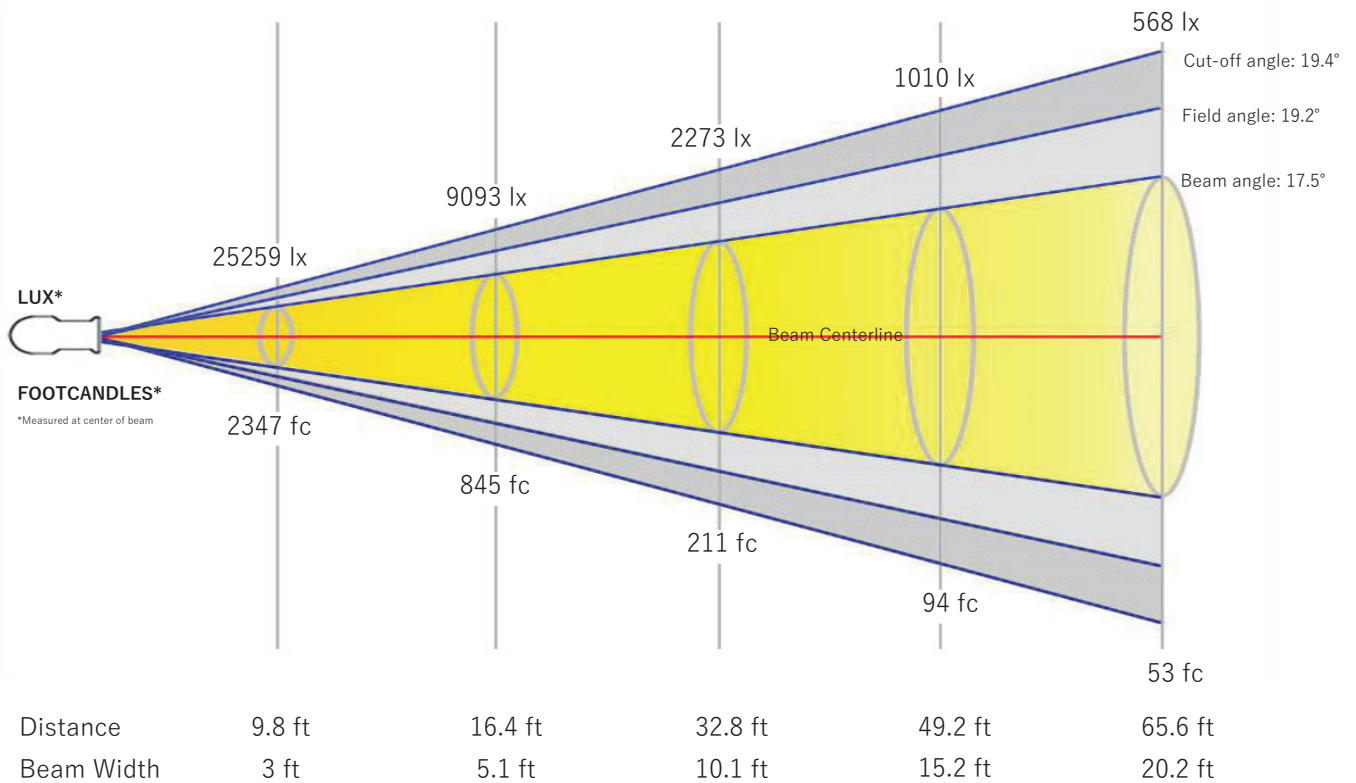

Beam Intensities from 1-20m

M	1	2	3	4	5	6	7	8	9	10	11	12	13	14	15	16	17	18	19	20
LX	227335	56834	25259	14208	9093	6315	4639	3552	2807	2273	1879	1579	1345	1160	1010	888	787	702	630	568
FT	3.3	6.6	9.8	13.1	16.4	19.7	23	26.2	29.5	32.8	36.1	39.4	42.7	45.9	49.2	52.5	55.8	59.1	62.3	65.6
FC	21120.2	5280	2346.7	1320	844.8	586.7	431	330	260.7	211.2	174.5	146.7	125	107.8	93.9	82.5	73.1	65.2	58.5	52.8

Angular Distribution

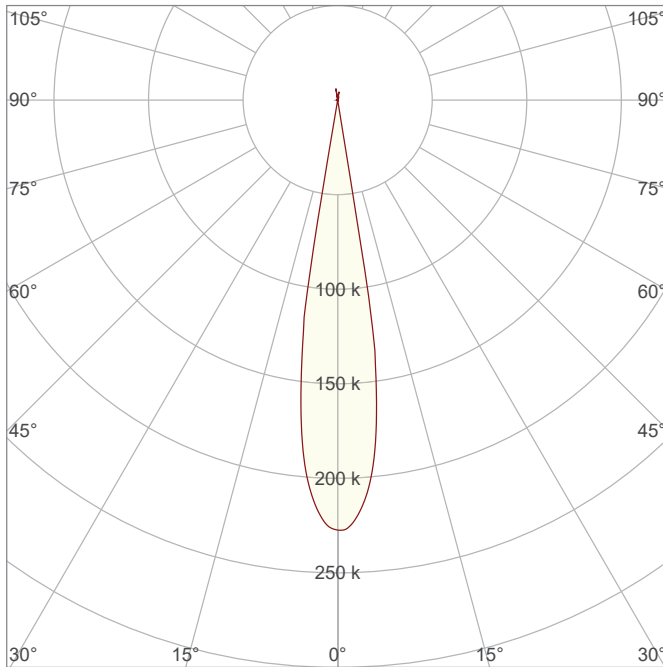

Beam Angle - 50%
17.5°
Field Angle - 10%
19.2°
Cutoff Angle - 2.5%
19.4°

ISO Diagrams

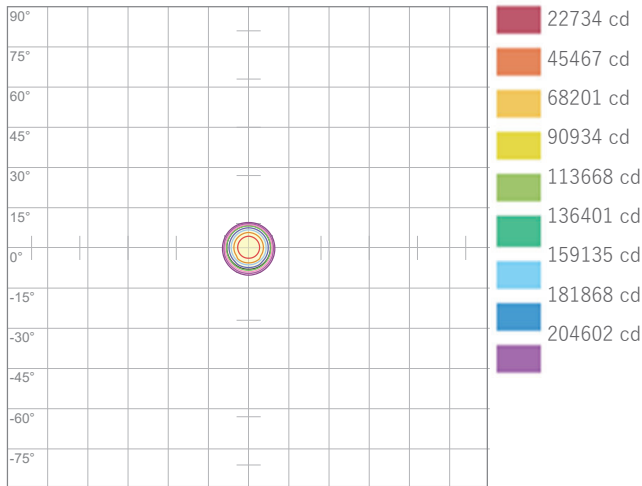

ISO Candela Diagram

Conditions:
Number of c-planes: 2
Candela at center: 227335 cd

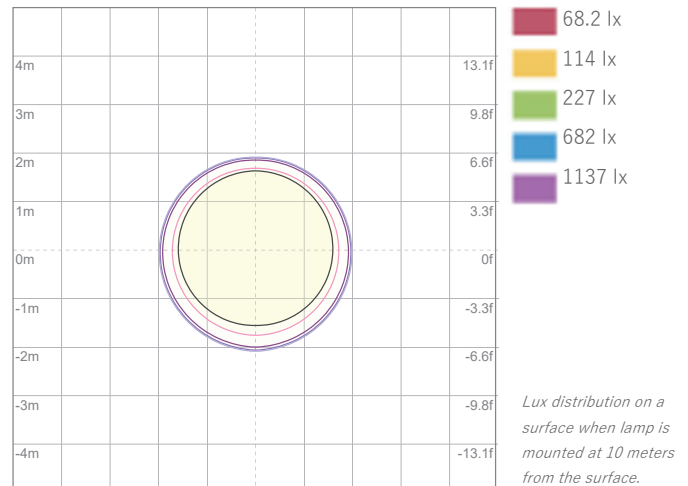

ISO LUX Diagram

Conditions:
Number of c-planes: 2
LUX at center: 2273 lx

Lux distribution on a surface when lamp is mounted at 10 meters from the surface.

Linear Distribution

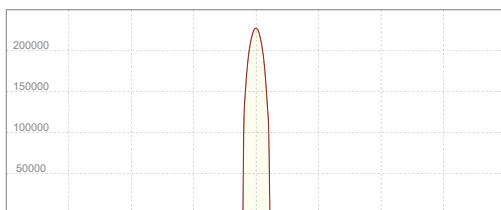

Peak Candela
227439 cd

Calculate Center Beam Intensities

$$\text{lux} = 227439 / \text{distance(m)}^2$$

$$\text{fc} = 227439 / \text{distance(ft)}^2$$

Key Measurements

Output

Total Lumen Output: 9591 lm

Peak Intensity: 151087 cd

Beam

Beam Angle (50%): 17.6°

Field Angle (10%): 19.2°

Cutoff Angle (2.5%): 19.4°

Color

Color Temperature: 5539 K

CRI: 92.5

TLCI: 90

TM30 R_F: 88.9

TM30 R_g: 99.8

Power Details

Efficacy: 12 Lumen/Watt

Power: 774.7 W

Supply Voltage: 230 V

Current: 3.38 A

Beam Details

Distance	3 m	5 m	10 m	15 m	20 m
Beam Width	0.9 m	1.5 m	3.1 m	4.6 m	6.2 m

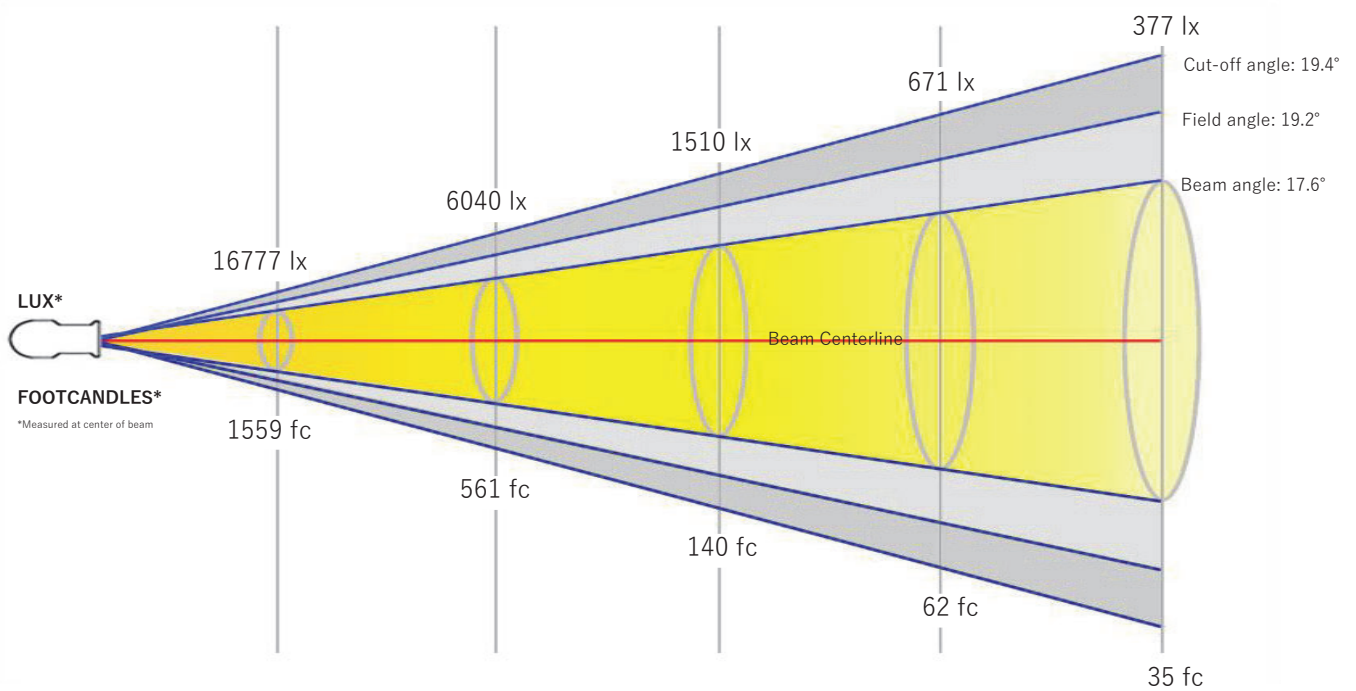

Distance	9.8 ft	16.4 ft	32.8 ft	49.2 ft	65.6 ft
Beam Width	3 ft	5.1 ft	10.2 ft	15.2 ft	20.3 ft

Beam Intensities from 1-20m

M	1	2	3	4	5	6	7	8	9	10	11	12	13	14	15	16	17	18	19	20
LX	150993	37748	16777	9437	6040	4194	3081	2359	1864	1510	1248	1049	893	770	671	590	522	466	418	377
FT	3.3	6.6	9.8	13.1	16.4	19.7	23	26.2	29.5	32.8	36.1	39.4	42.7	45.9	49.2	52.5	55.8	59.1	62.3	65.6
FC	14027.7	3506.9	1558.6	876.7	561.1	389.7	286.3	219.2	173.2	140.3	115.9	97.4	83	71.6	62.3	54.8	48.5	43.3	38.9	35.1

Angular Distribution

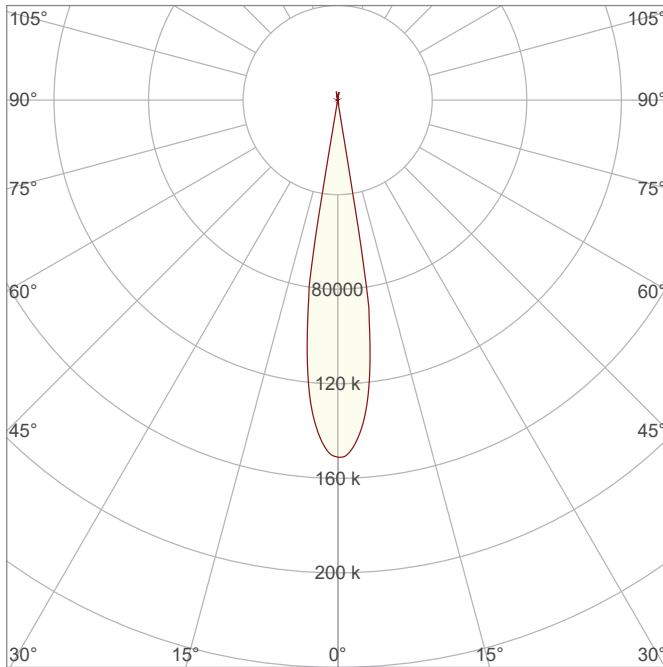

Beam Angle - 50%
17.6°
Field Angle - 10%
19.2°
Cutoff Angle - 2.5%
19.4°

ISO Diagrams

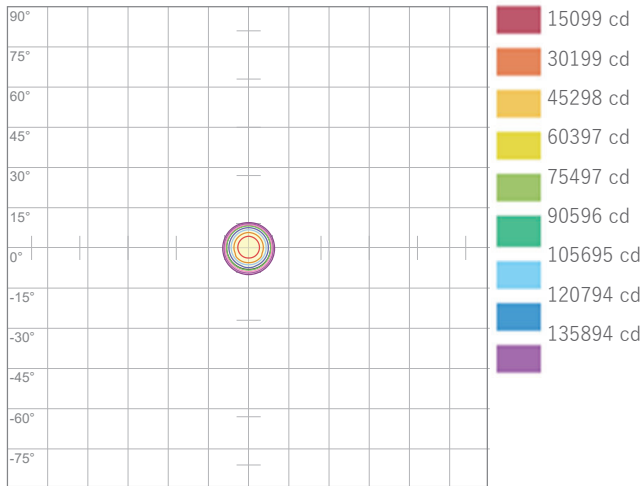

ISO Candela Diagram

Conditions:
Number of c-planes: 2
Candela at center: 150993 cd

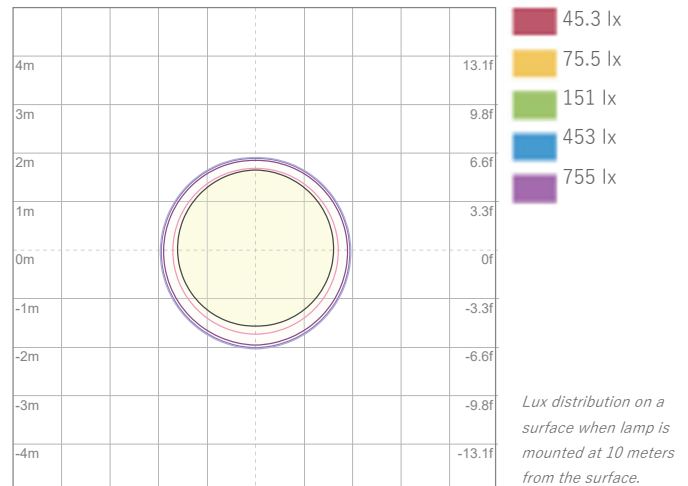

ISO LUX Diagram

Conditions:
Number of c-planes: 2
LUX at center: 1510 lx

Lux distribution on a surface when lamp is mounted at 10 meters from the surface.

Linear Distribution

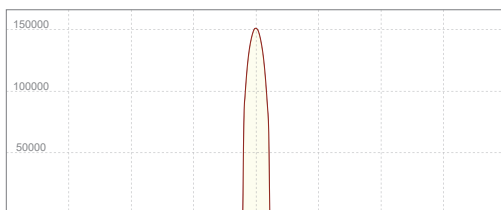

Peak Candela
151087 cd

Calculate Center Beam Intensities

$$\text{lux} = 151087 / \text{distance(m)}^2$$

$$\text{fc} = 151087 / \text{distance(ft)}^2$$

Key Measurements

Output

Total Lumen Output: 3973 lm
Peak Intensity: 62488 cd

Beam

Beam Angle (50%): 17.9°
Field Angle (10%): 19.2°
Cutoff Angle (2.5%): 19.7°

Color

Color Temperature: 2428 K
CRI: 90.9
TLCI: 67
TM30 R_F: 89.2
TM30 R_g: 101.5

Power Details

Efficacy: 5 Lumen/Watt
Power: 769.5 W
Supply Voltage: 230 V
Current: 3.36 A

Beam Details

Distance	3 m	5 m	10 m	15 m	20 m
Beam Width	0.9 m	1.6 m	3.1 m	4.7 m	6.3 m

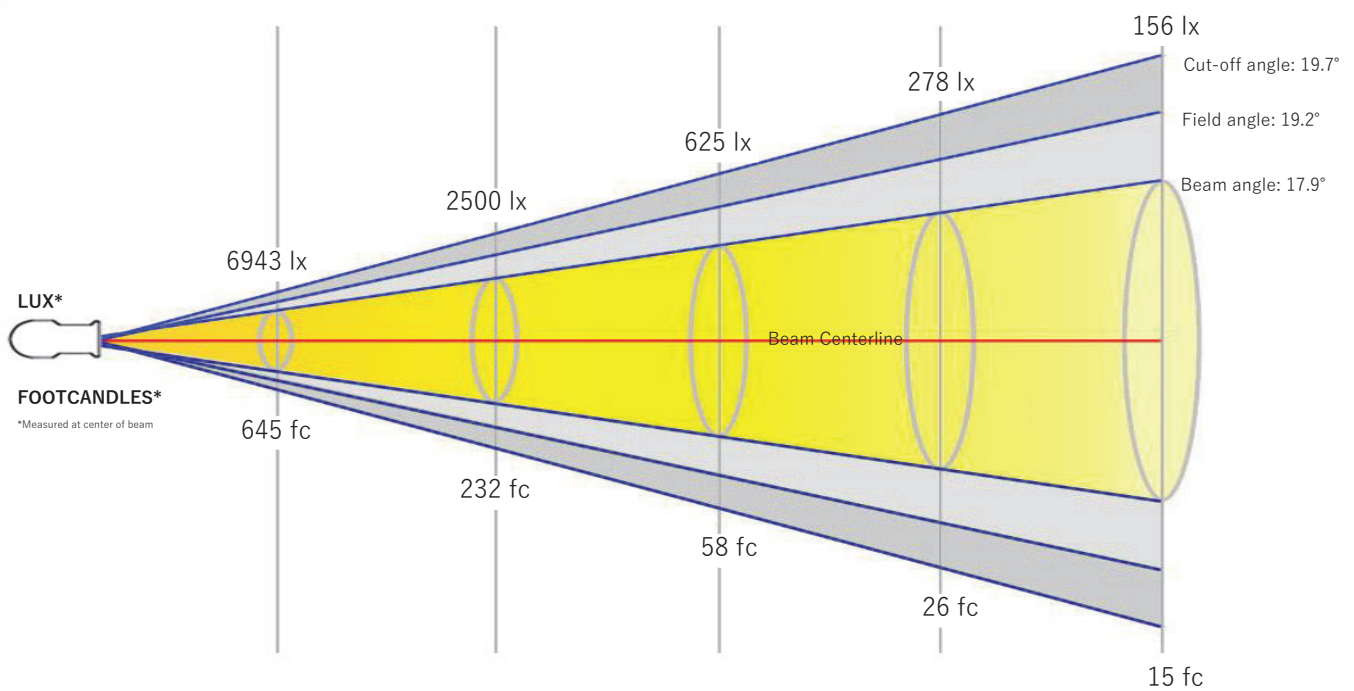

Distance	9.8 ft	16.4 ft	32.8 ft	49.2 ft	65.6 ft
Beam Width	3.1 ft	5.2 ft	10.3 ft	15.5 ft	20.6 ft

Beam Intensities from 1-20m

M	1	2	3	4	5	6	7	8	9	10	11	12	13	14	15	16	17	18	19	20
LX	62488	15622	6943	3906	2500	1736	1275	976	771	625	516	434	370	319	278	244	216	193	173	156
FT	3.3	6.6	9.8	13.1	16.4	19.7	23	26.2	29.5	32.8	36.1	39.4	42.7	45.9	49.2	52.5	55.8	59.1	62.3	65.6
FC	5805.3	1451.3	645	362.8	232.2	161.3	118.5	90.7	71.7	58.1	48	40.3	34.4	29.6	25.8	22.7	20.1	17.9	16.1	14.5

Angular Distribution

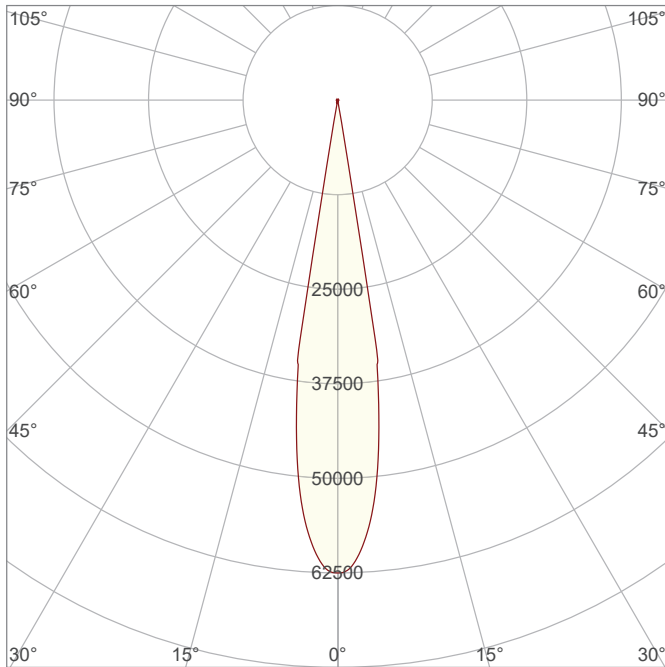

Beam Angle - 50%
17.9°
Field Angle - 10%
19.2°
Cutoff Angle - 2.5%
19.7°

ISO Diagrams

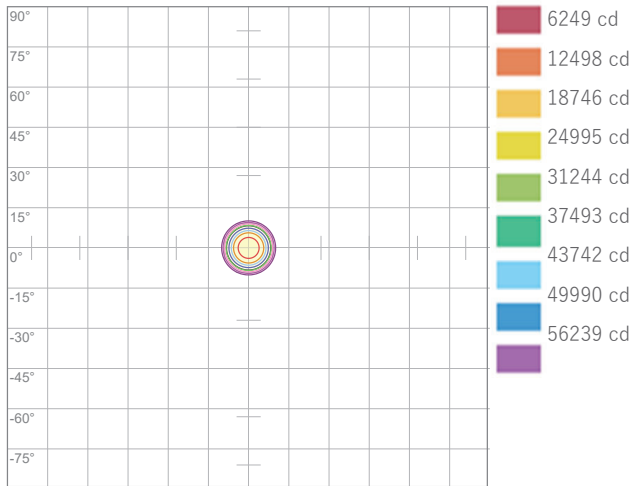

ISO Candela Diagram

Conditions:
Number of c-planes: 2
Candela at center: 62488 cd

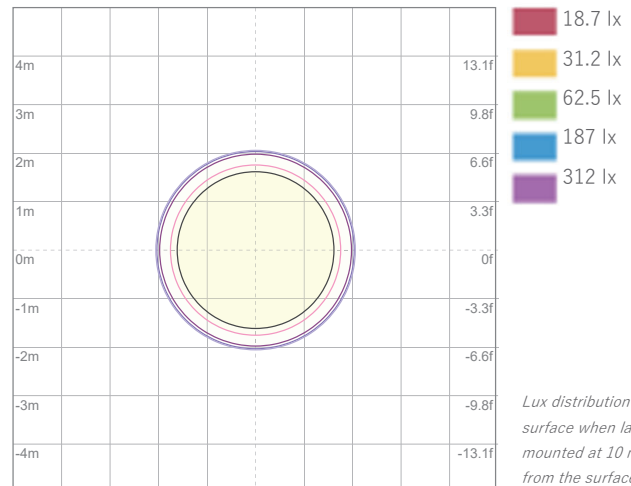

ISO LUX Diagram

Conditions:
Number of c-planes: 2
LUX at center: 625 lx

Lux distribution on a surface when lamp is mounted at 10 meters from the surface.

Linear Distribution

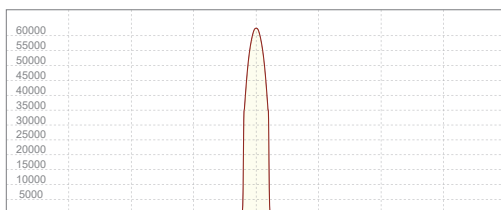

Peak Candela
62488 cd

Calculate Center Beam Intensities

$$\text{lux} = 62488 / \text{distance(m)}^2$$

$$\text{fc} = 62488 / \text{distance(ft)}^2$$

Key Measurements

Output

Total Lumen Output: 3171 lm

Peak Intensity: 49342 cd

Beam

Beam Angle (50%): 17.7°

Field Angle (10%): 19.1°

Cutoff Angle (2.5%): 19.9°

Color

Color Temperature: 2320 K

CRI: 89.1

TLCI: 66

TM30 R_F: 87.7

TM30 R_g: 103.9

Power Details

Efficacy: 4 Lumen/Watt

Power: 772.4 W

Supply Voltage: 230 V

Current: 3.37 A

Beam Details

Distance	3 m	5 m	10 m	15 m	20 m
Beam Width	0.9 m	1.6 m	3.1 m	4.7 m	6.2 m

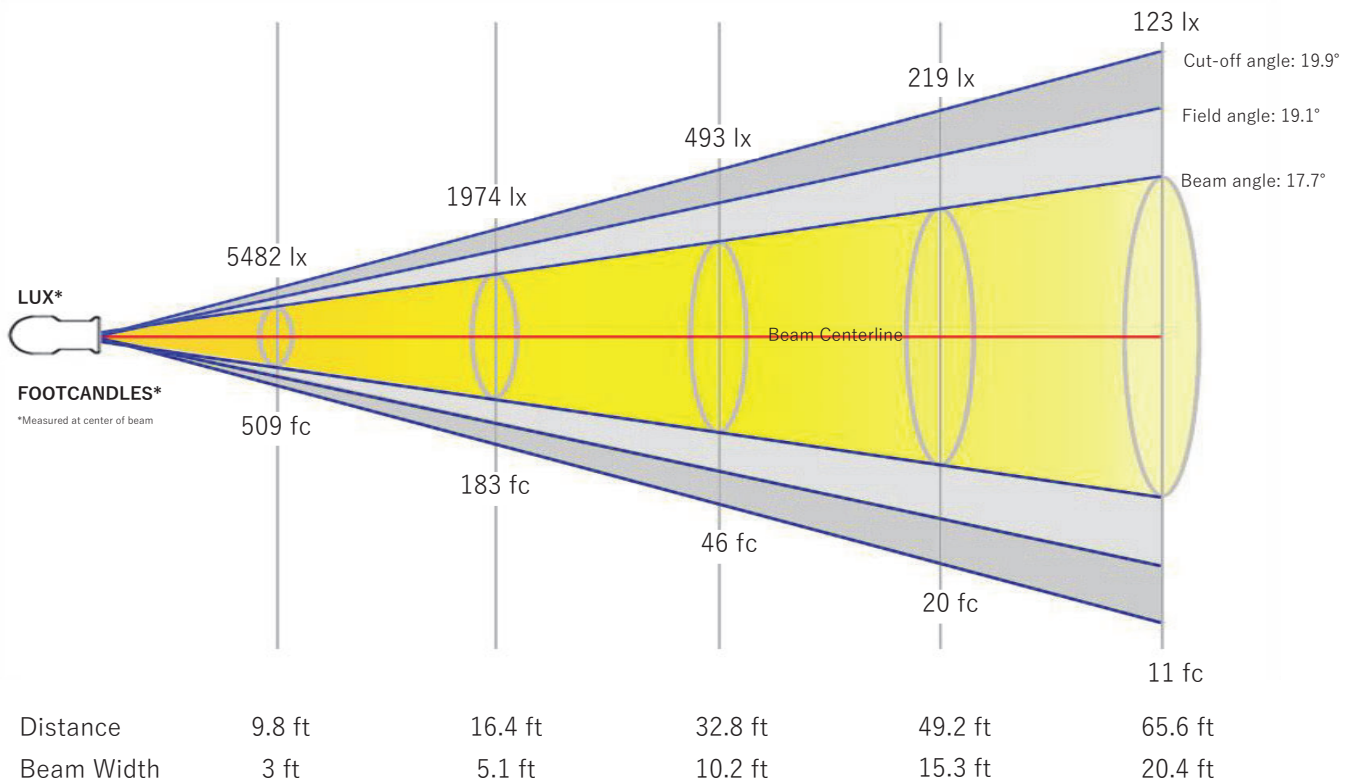

Beam Intensities from 1-20m

M	1	2	3	4	5	6	7	8	9	10	11	12	13	14	15	16	17	18	19	20
LX	49342	12336	5482	3084	1974	1371	1007	771	609	493	408	343	292	252	219	193	171	152	137	123
FT	3.3	6.6	9.8	13.1	16.4	19.7	23	26.2	29.5	32.8	36.1	39.4	42.7	45.9	49.2	52.5	55.8	59.1	62.3	65.6
FC	4584.1	1146	509.3	286.5	183.4	127.3	93.6	71.6	56.6	45.8	37.9	31.8	27.1	23.4	20.4	17.9	15.9	14.1	12.7	11.5

Angular Distribution

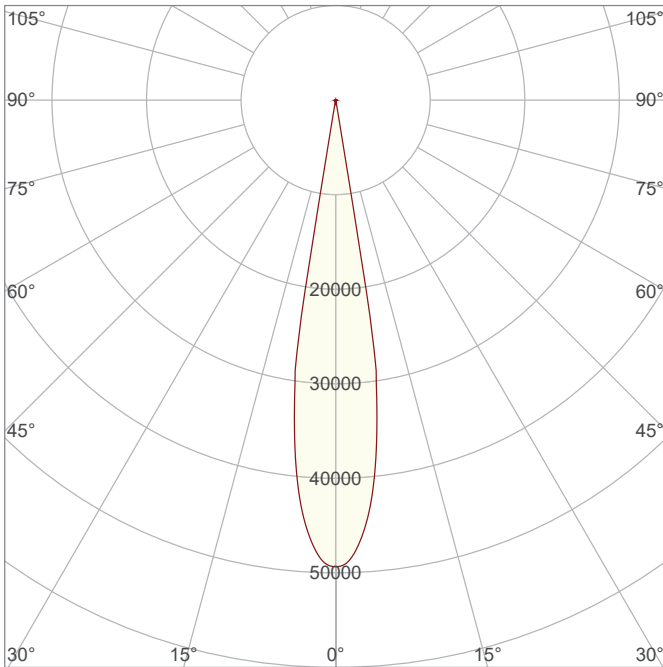

Beam Angle - 50%
17.7°
Field Angle - 10%
19.1°
Cutoff Angle - 2.5%
19.9°

ISO Diagrams

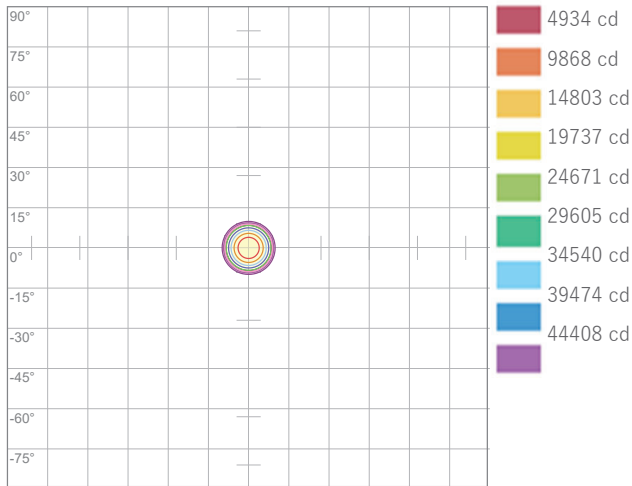

ISO Candela Diagram

Conditions:
Number of c-planes: 2
Candela at center: 49342 cd

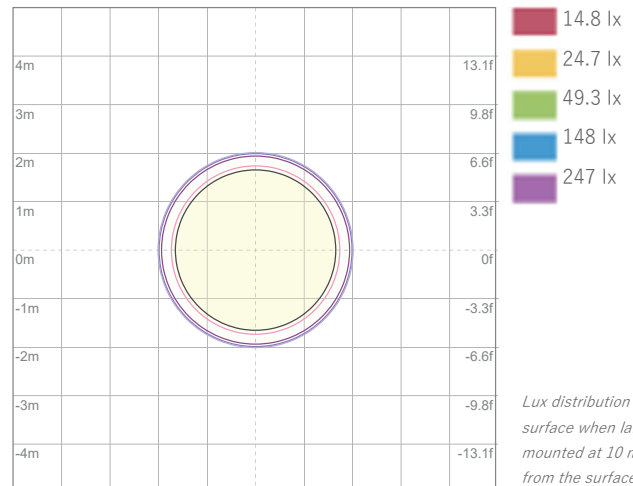

ISO LUX Diagram

Conditions:
Number of c-planes: 2
LUX at center: 493 lx

Lux distribution on a surface when lamp is mounted at 10 meters from the surface.

Linear Distribution

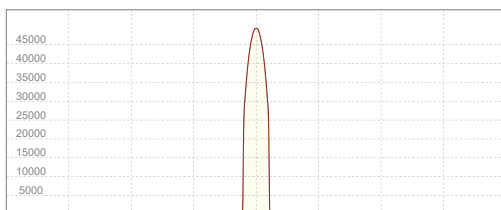

Peak Candela
49342 cd

Calculate Center Beam Intensities

$$\text{lux} = 49342 / \text{distance(m)}^2$$

$$\text{fc} = 49342 / \text{distance(ft)}^2$$

Key Measurements

Output

Total Lumen Output: 16393 lm

Peak Intensity: 260447 cd

Beam

Beam Angle (50%): 17.5°

Field Angle (10%): 19.1°

Cutoff Angle (2.5%): 19.7°

Color

Color Temperature: 6463 K

CRI: 70.6

TLCI: 49

TM30 R_F: 71.9

TM30 R_g: 93.1

Power Details

Efficacy: 26 Lumen/Watt

Power: 640.3 W

Supply Voltage: 229 V

Current: 2.81 A

Beam Details

Distance	3 m	5 m	10 m	15 m	20 m
Beam Width	0.9 m	1.5 m	3.1 m	4.6 m	6.2 m

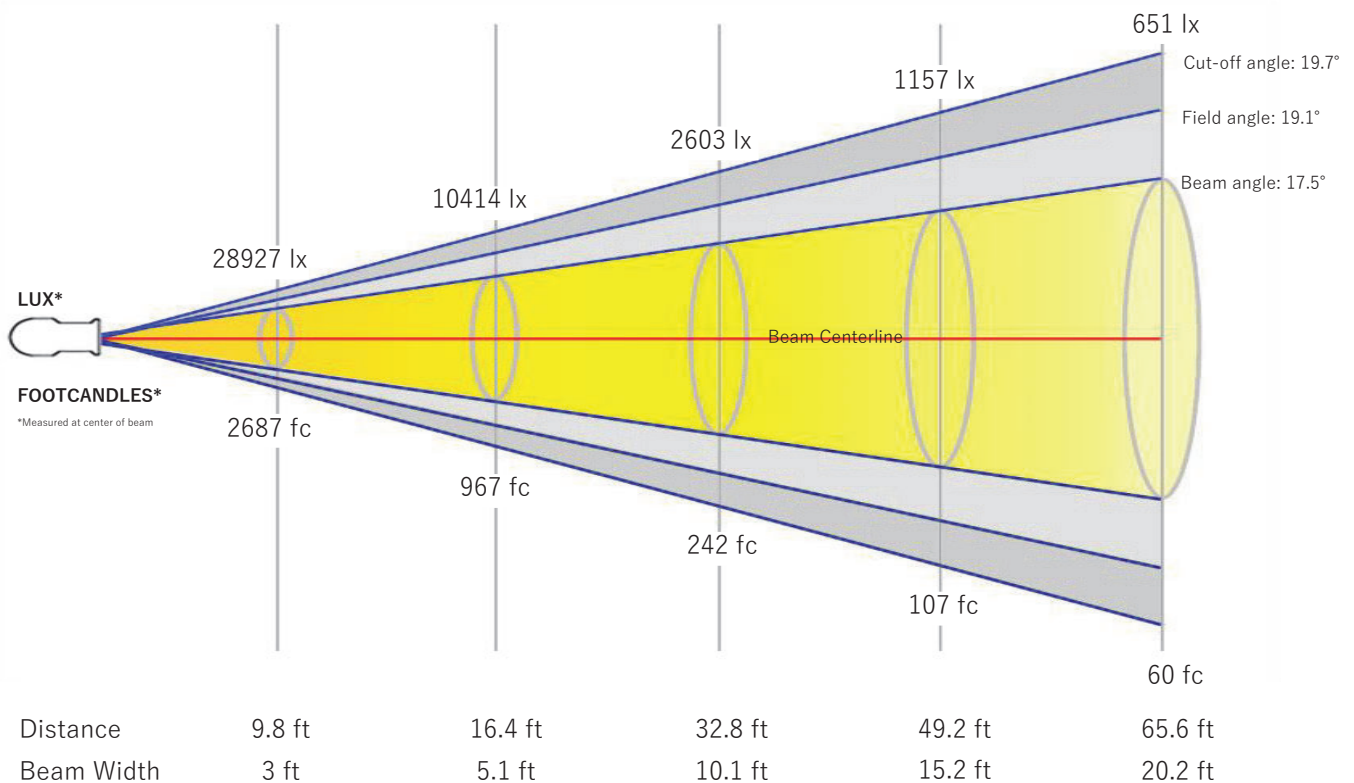

Beam Intensities from 1-20m

M	1	2	3	4	5	6	7	8	9	10	11	12	13	14	15	16	17	18	19	20
LX	260339	65085	28927	16271	10414	7232	5313	4068	3214	2603	2152	1808	1540	1328	1157	1017	901	804	721	651
FT	3.3	6.6	9.8	13.1	16.4	19.7	23	26.2	29.5	32.8	36.1	39.4	42.7	45.9	49.2	52.5	55.8	59.1	62.3	65.6
FC	24186.3	6046.6	2687.4	1511.6	967.5	671.8	493.6	377.9	298.6	241.9	199.9	168	143.1	123.4	107.5	94.5	83.7	74.6	67	60.5

Angular Distribution

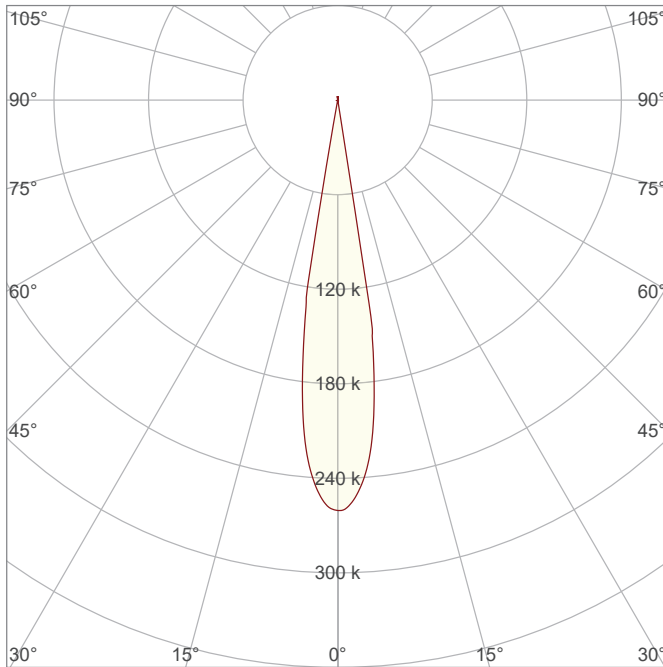

Beam Angle - 50%
17.5°
Field Angle - 10%
19.1°
Cutoff Angle - 2.5%
19.7°

ISO Diagrams

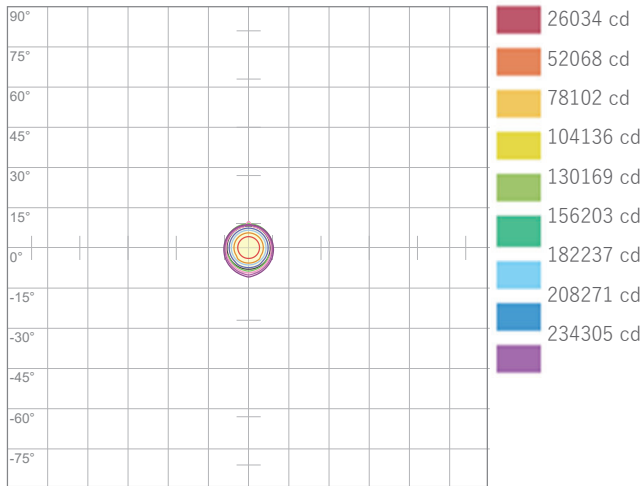

ISO Candela Diagram

Conditions:
Number of c-planes: 2
Candela at center: 260339 cd

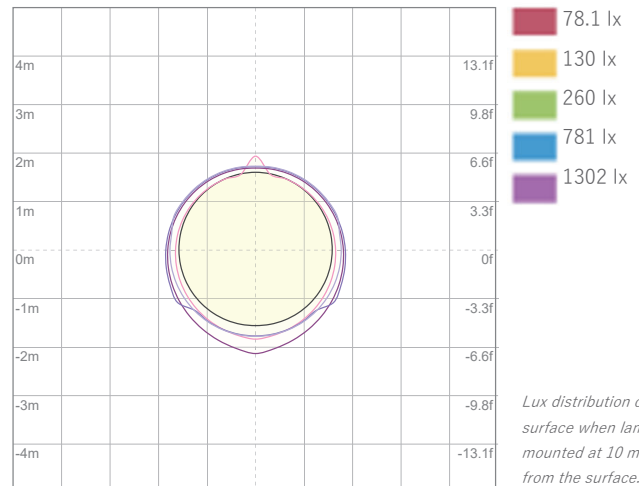

ISO LUX Diagram

Conditions:
Number of c-planes: 2
LUX at center: 2603 lx

Lux distribution on a surface when lamp is mounted at 10 meters from the surface.

Linear Distribution

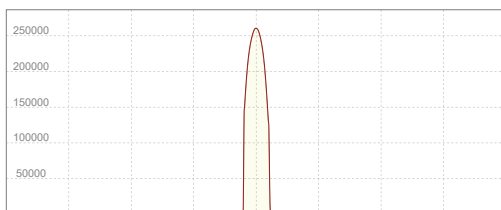

Peak Candela
260447 cd

Calculate Center Beam Intensities

$$\text{lux} = 260447 / \text{distance(m)}^2$$

$$\text{fc} = 260447 / \text{distance(ft)}^2$$

Key Measurements

Output

Total Lumen Output: 12490 lm

Peak Intensity: 198658 cd

Beam

Beam Angle (50%): 17.4°

Field Angle (10%): 19.1°

Cutoff Angle (2.5%): 19.7°

Color

Color Temperature: 6429 K

CRI: 70.3

TLCI: 48

TM30 R_F: 71.6

TM30 R_g: 93.2

Power Details

Efficacy: 24 Lumen/Watt

Power: 512.7 W

Supply Voltage: 232 V

Current: 2.23 A

Beam Details

Distance	3 m	5 m	10 m	15 m	20 m
Beam Width	0.9 m	1.5 m	3.1 m	4.6 m	6.1 m

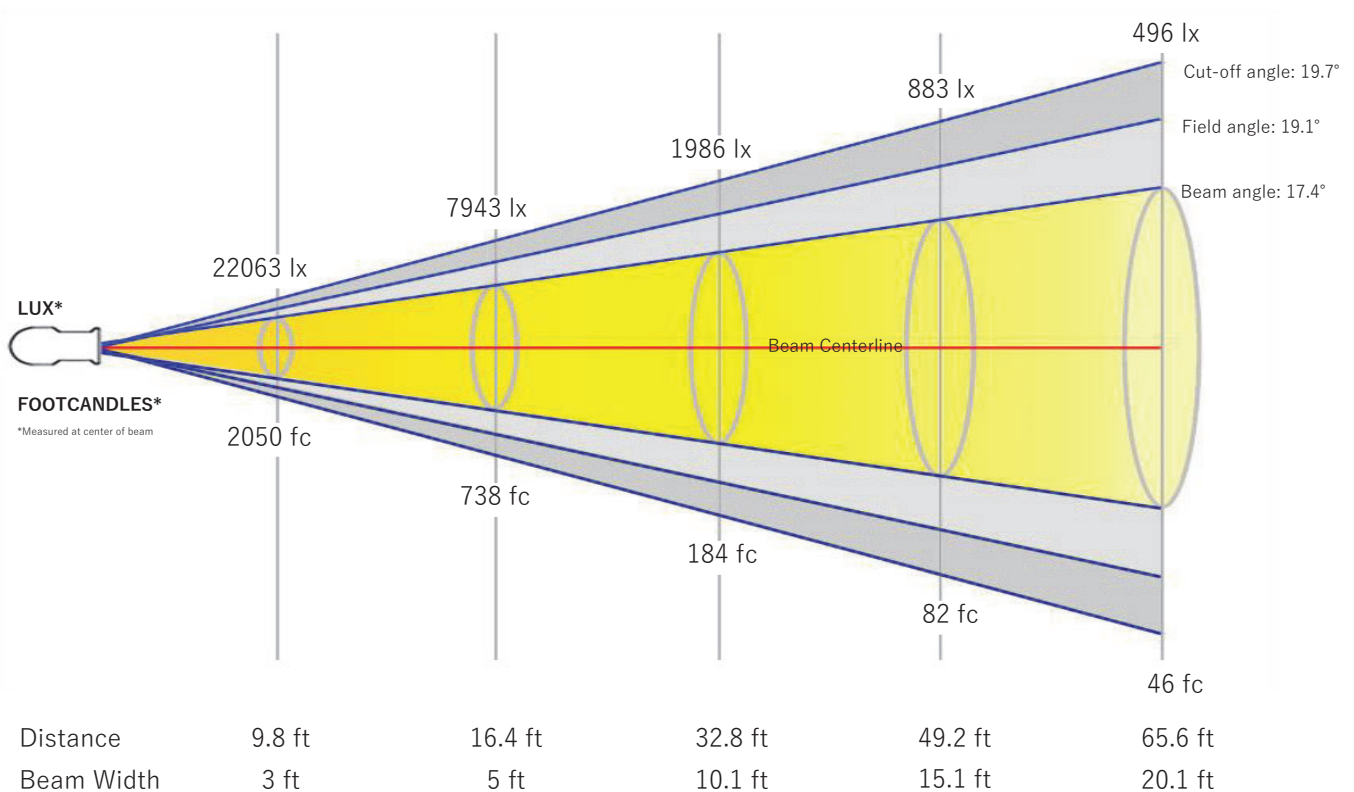

Beam Intensities from 1-20m

M	1	2	3	4	5	6	7	8	9	10	11	12	13	14	15	16	17	18	19	20
LX	198570	49642	22063	12411	7943	5516	4052	3103	2451	1986	1641	1379	1175	1013	883	776	687	613	550	496
FT	3.3	6.6	9.8	13.1	16.4	19.7	23	26.2	29.5	32.8	36.1	39.4	42.7	45.9	49.2	52.5	55.8	59.1	62.3	65.6
FC	18447.7	4611.9	2049.7	1153	737.9	512.4	376.5	288.2	227.7	184.5	152.5	128.1	109.2	94.1	82	72.1	63.8	56.9	51.1	46.1

Angular Distribution

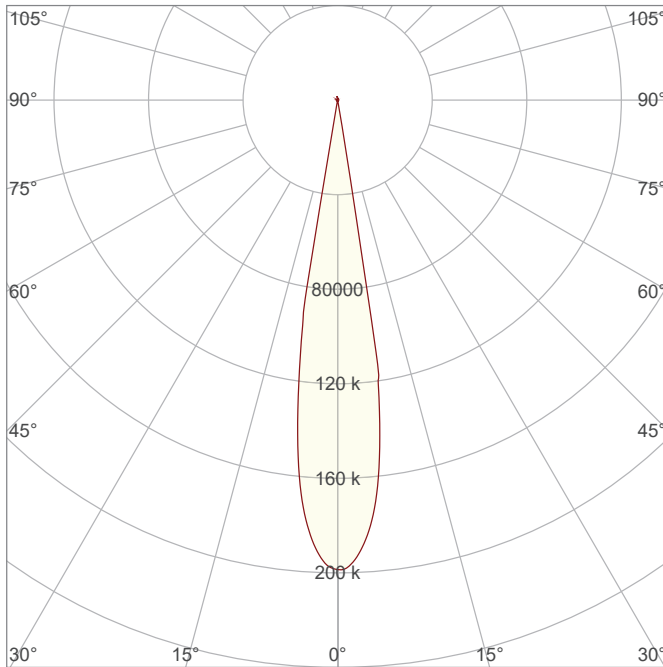

Beam Angle - 50%
17.4°
Field Angle - 10%
19.1°
Cutoff Angle - 2.5%
19.7°

ISO Diagrams

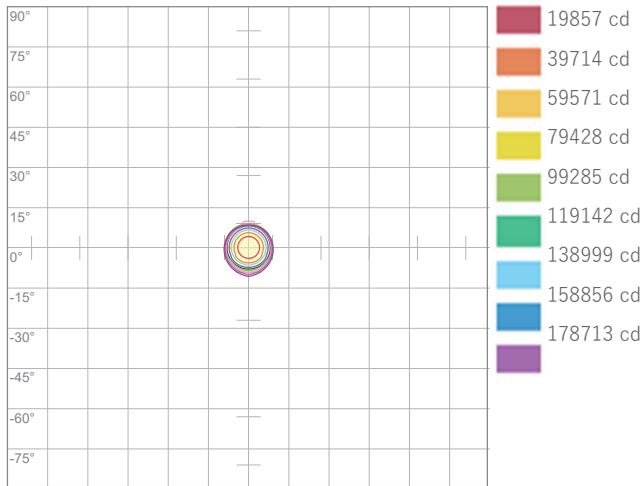

ISO Candela Diagram

Conditions:
Number of c-planes: 2
Candela at center: 198570 cd

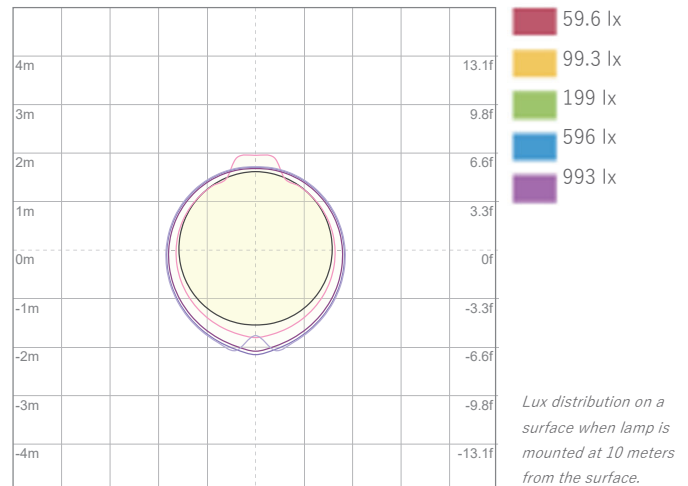

ISO LUX Diagram

Conditions:
Number of c-planes: 2
LUX at center: 1986 lx

Lux distribution on a surface when lamp is mounted at 10 meters from the surface.

Linear Distribution

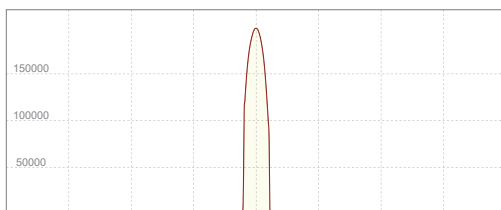

Peak Candela
198658 cd

Calculate Center Beam Intensities

$$\text{lux} = 198658 / \text{distance(m)}^2$$

$$\text{fc} = 198658 / \text{distance(ft)}^2$$

Key Measurements

Output

Total Lumen Output: 3120 lm

Peak Intensity: 46690 cd

Beam

Beam Angle (50%): 17.8°

Field Angle (10%): 19.3°

Cutoff Angle (2.5%): 19.7°

Color

Color Temperature: 6357 K

CRI: 70.1

TLCI: 48

TM30 R_F: 71.6

TM30 R_g: 93.1

Power Details

Efficacy: 15 Lumen/Watt

Power: 212.7 W

Supply Voltage: 233 V

Current: 0.957 A

Beam Details

Distance	3 m	5 m	10 m	15 m	20 m
Beam Width	0.9 m	1.6 m	3.1 m	4.7 m	6.3 m

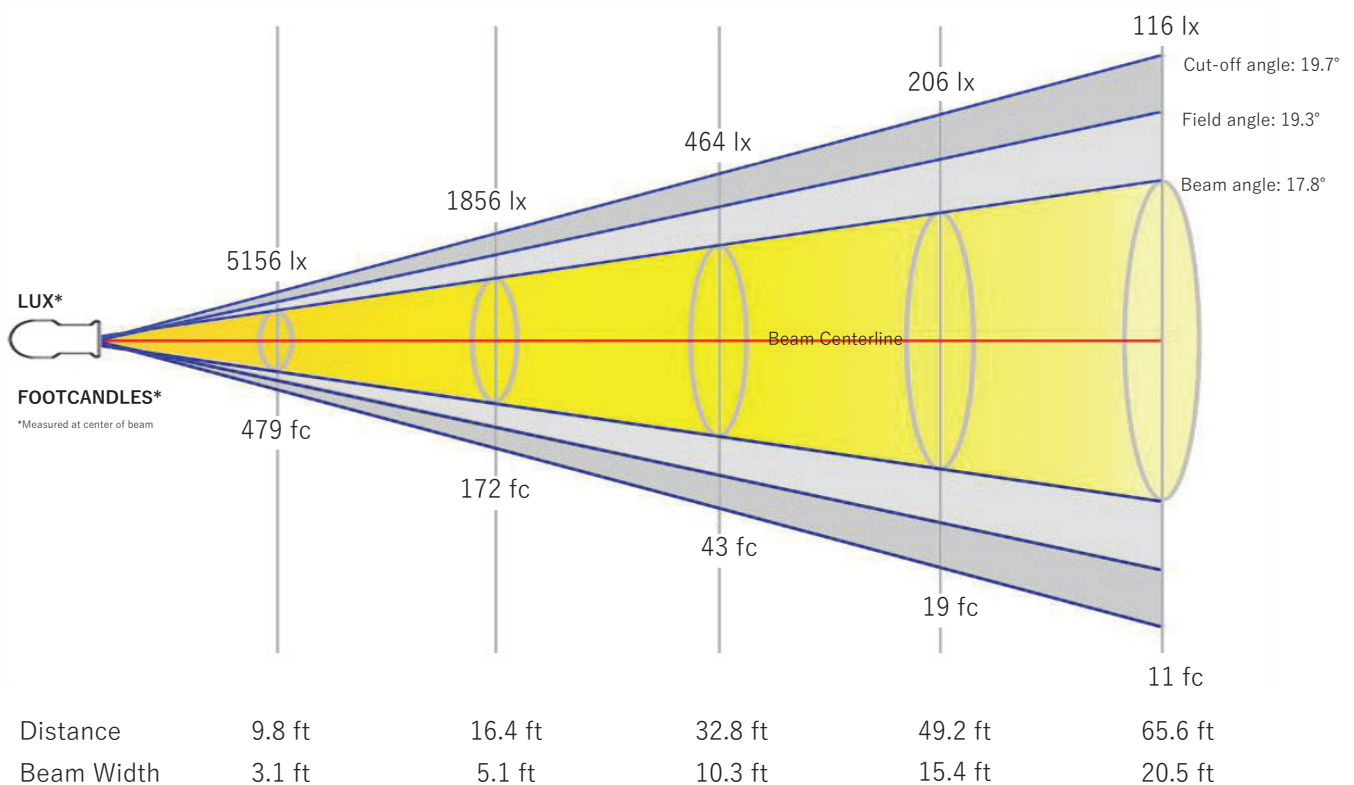

Beam Intensities from 1-20m

M	1	2	3	4	5	6	7	8	9	10	11	12	13	14	15	16	17	18	19	20
LX	46407	11602	5156	2900	1856	1289	947	725	573	464	384	322	275	237	206	181	161	143	129	116
FT	3.3	6.6	9.8	13.1	16.4	19.7	23	26.2	29.5	32.8	36.1	39.4	42.7	45.9	49.2	52.5	55.8	59.1	62.3	65.6
FC	4311.4	1077.8	479	269.5	172.5	119.8	88	67.4	53.2	43.1	35.6	29.9	25.5	22	19.2	16.8	14.9	13.3	11.9	10.8

Angular Distribution

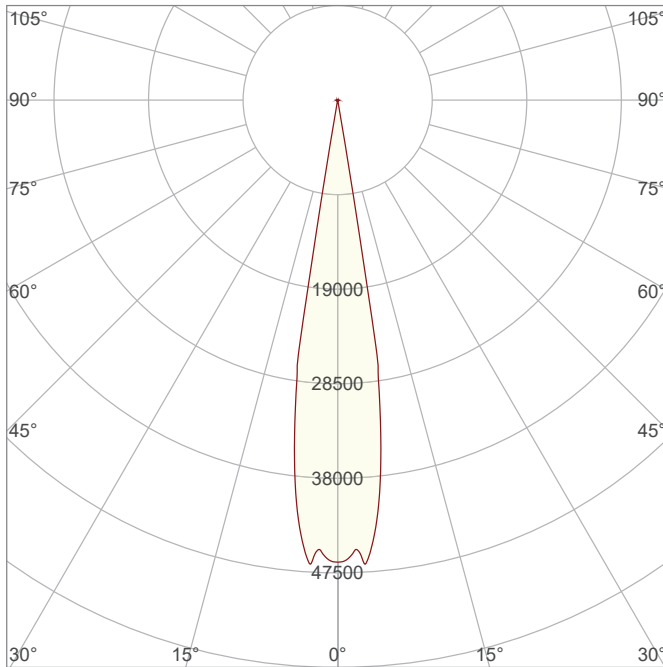

Beam Angle - 50%
17.8°
Field Angle - 10%
19.3°
Cutoff Angle - 2.5%
19.7°

ISO Diagrams

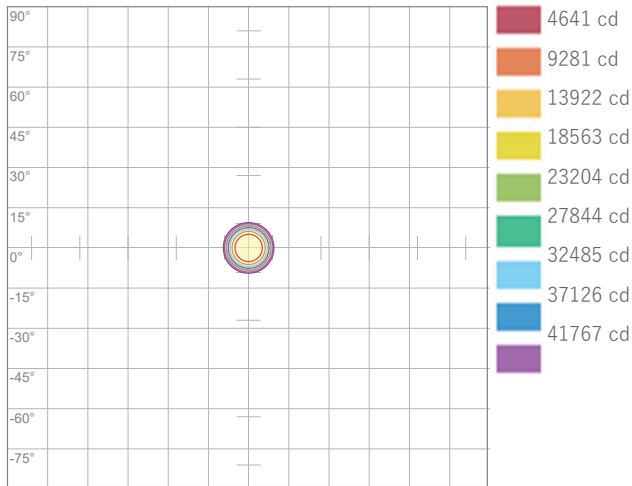

ISO Candela Diagram

Conditions:
Number of c-planes: 2
Candela at center: 46407 cd

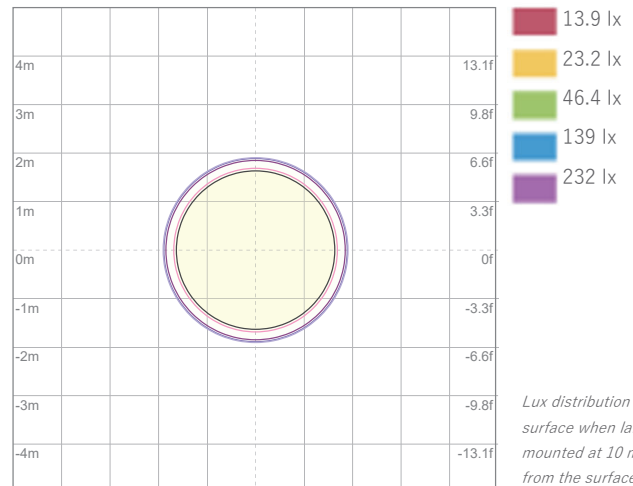

ISO LUX Diagram

Conditions:
Number of c-planes: 2
LUX at center: 464 lx

Lux distribution on a surface when lamp is mounted at 10 meters from the surface.

Linear Distribution

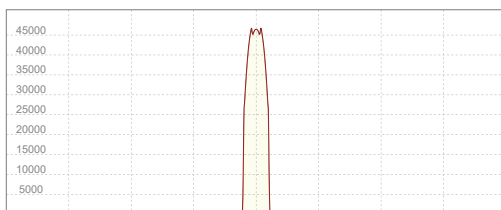

Peak Candela
46690 cd

Calculate Center Beam Intensities

$$\text{lux} = 46690 / \text{distance(m)}^2$$

$$\text{fc} = 46690 / \text{distance(ft)}^2$$

Color Temperature: 6651K

Accuracy Metric Overview

Color Rendering Index	Color Rendering Index, R9 (Red Component)	TM-30 Color Fidelity	TM-30 Color Gamut	Television Lighting Consistency Index	Color Quality Scale	Color Coordinate- CIE 1931	Color Coordinate- CIE 1931	Deviation from Black Body	SSI [CIE A] Tungsten	SSI [CIE D65] Daylight
CRI	CRI R9	TM30 R _f	TM30 R _g	TLCI	CQS	x	Y	Δuv	SSIt	SSId
71.8	-31.1	72.3	93.1	48	69.3	0.311	0.325	0.0020	13	52

CIE 1931

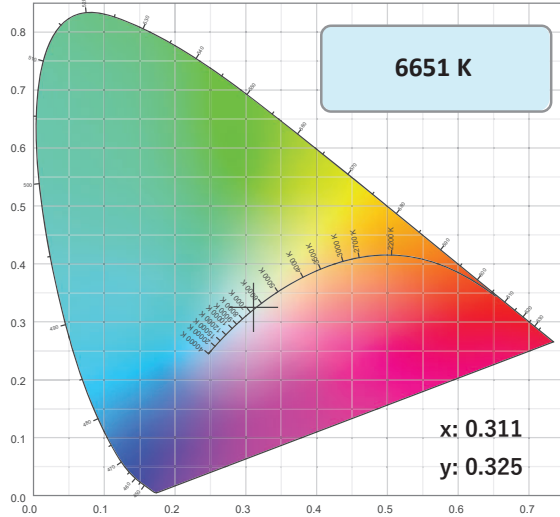

CIE 1931 ZOOMED

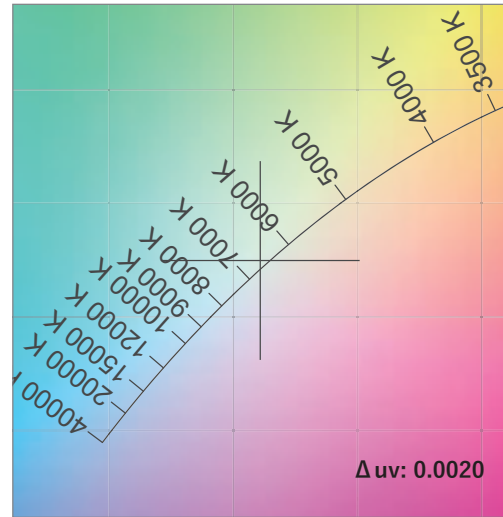

CRI: 71.8 (R1-R8)

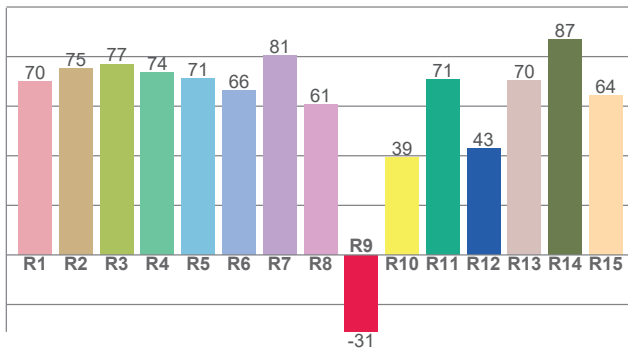

Spectral Power Distribution (SPD)

Dominant Wavelength 434 nm

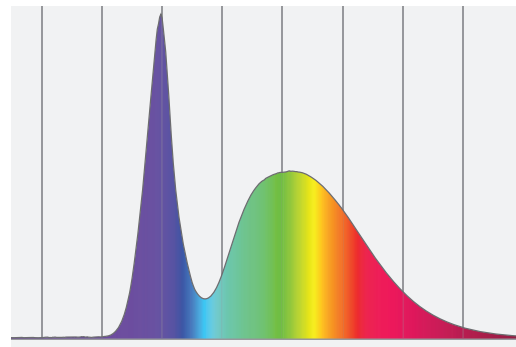

SSI Spectral Variance Graph- Tungsten

SSI [CIE A] 13

Spectral variance

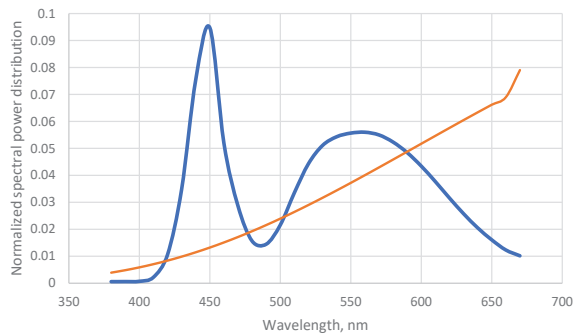

— Test Source — CIE Illuminant A - Tungsten

SSI Spectral Variance Graph- Daylight

SSI [CIE D65] 52

Spectral variance

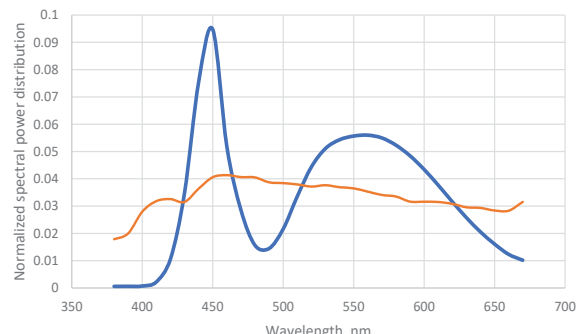

— Test Source — CIE Illuminant D65 - Daylight

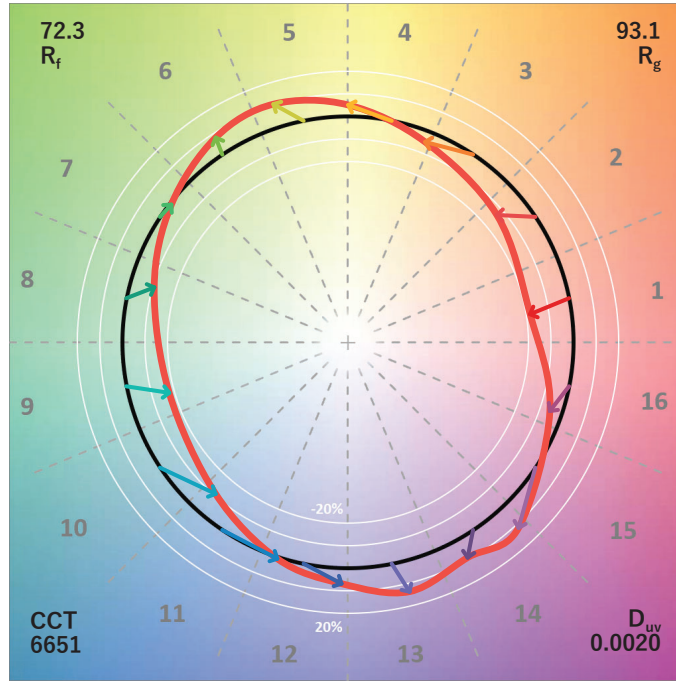

TM30-18 R_f Values per Hue Bin

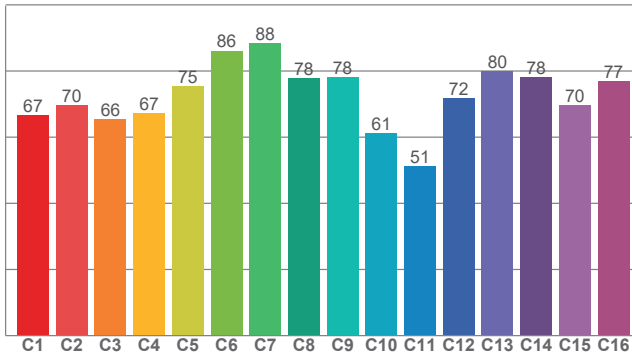

TM30 Chroma Shift per Hue Bin

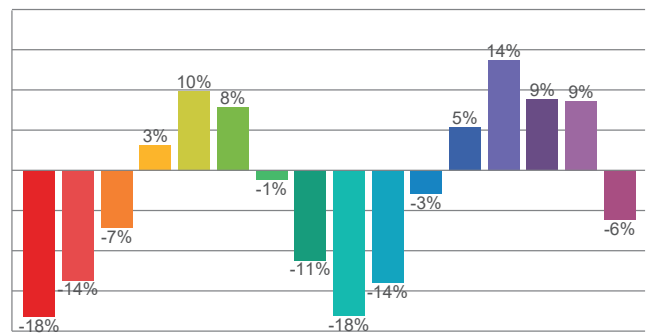

TM30-18 R_f Values per Reference Color (CES)

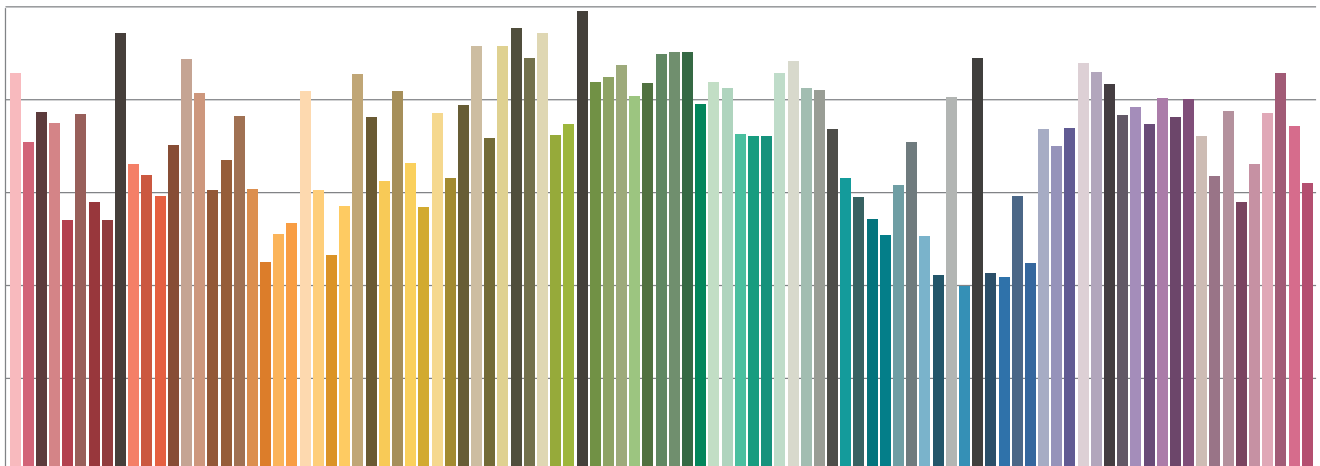

Color Temperature: 6626K

Accuracy Metric Overview

Color Rendering Index	Color Rendering Index, R9 (Red Component)	TM-30 Color Fidelity	TM-30 Color Gamut	Television Lighting Consistency Index	Color Quality Scale	Color Coordinate- CIE 1931	Color Coordinate- CIE 1931	Deviation from Black Body	SSI [CIE A] Tungsten	SSI [CIE D65] Daylight
CRI	CRI R9	TM30 R _f	TM30 R _g	TLCI	CQS	x	Y	Δuv	SSIt	SSId
88.0	41.0	83.9	100.7	78	82.9	0.313	0.313	-0.0054	14	53

CIE 1931

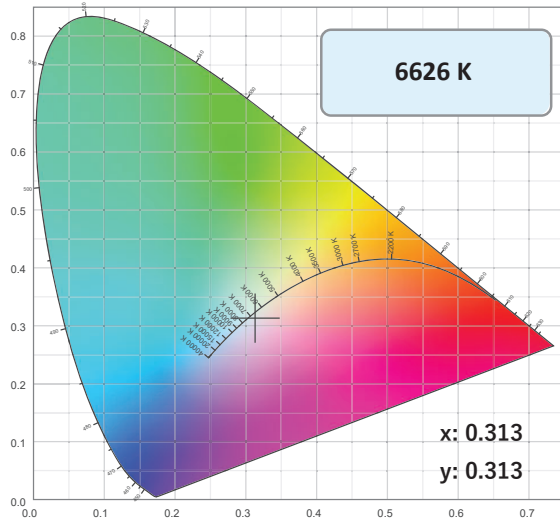

CIE 1931 ZOOMED

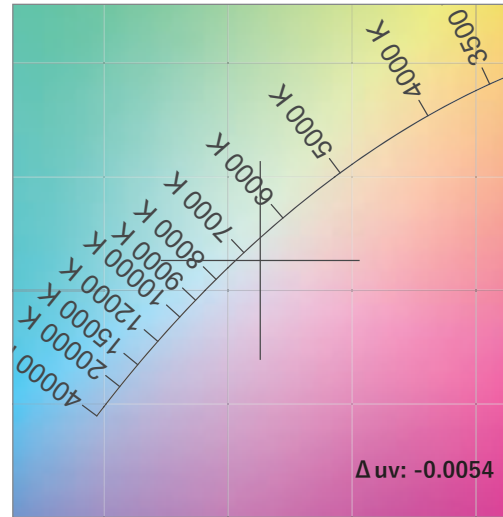

CRI: 88.0 (R1-R8)

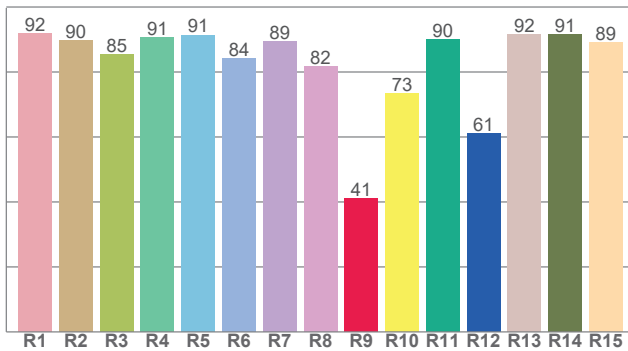

Spectral Power Distribution (SPD)

Dominant Wavelength 550 nm

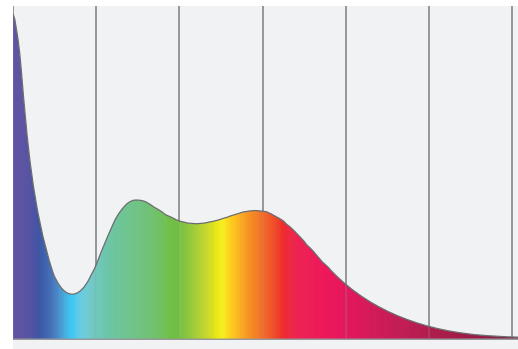

SSI Spectral Variance Graph- Tungsten

SSI [CIE A] 14

Spectral variance

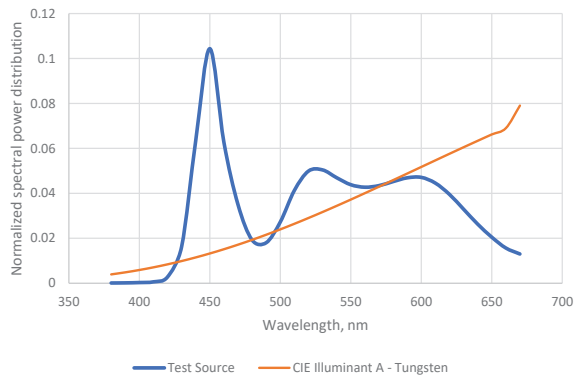

SSI Spectral Variance Graph- Daylight

SSI [CIE D65] 53

Spectral variance

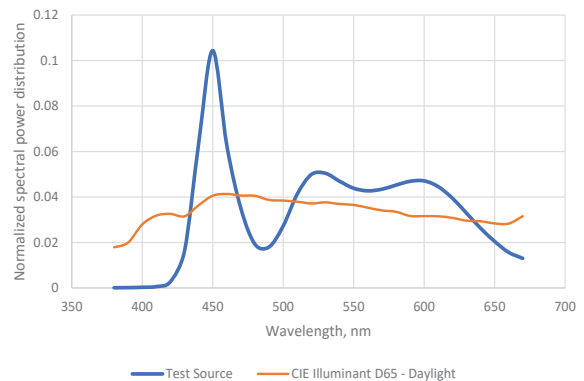

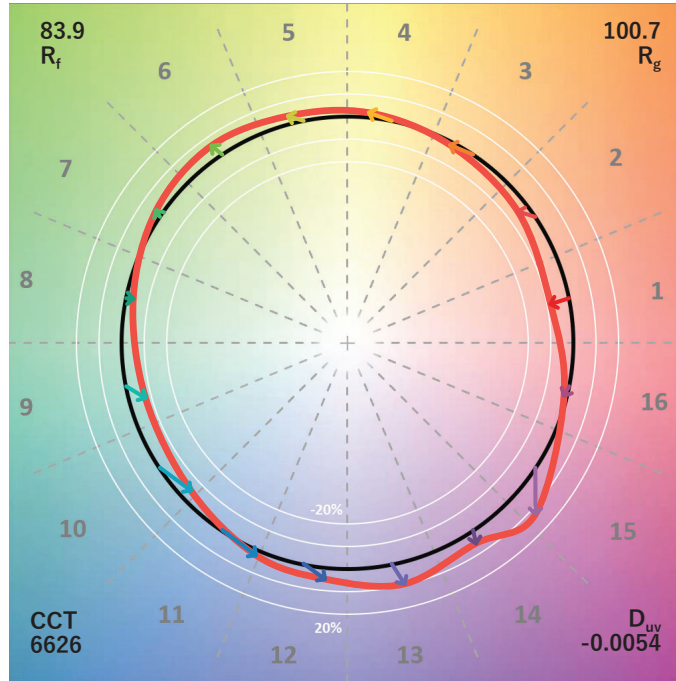

TM30-18 R_f Values per Hue Bin

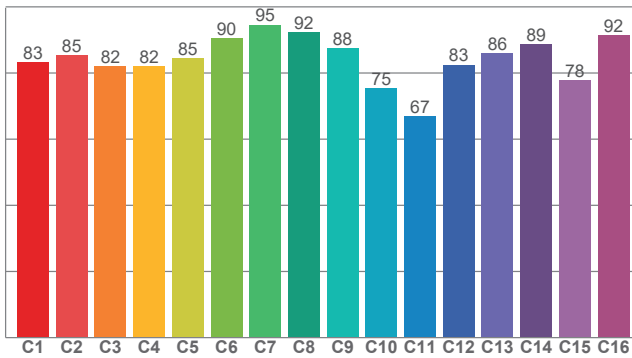

TM30 Chroma Shift per Hue Bin

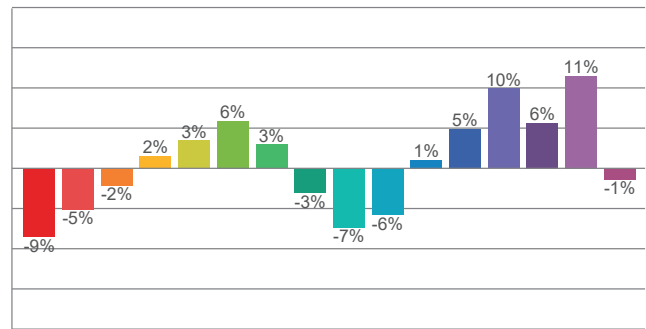

TM30-18 R_f Values per Reference Color (CES)

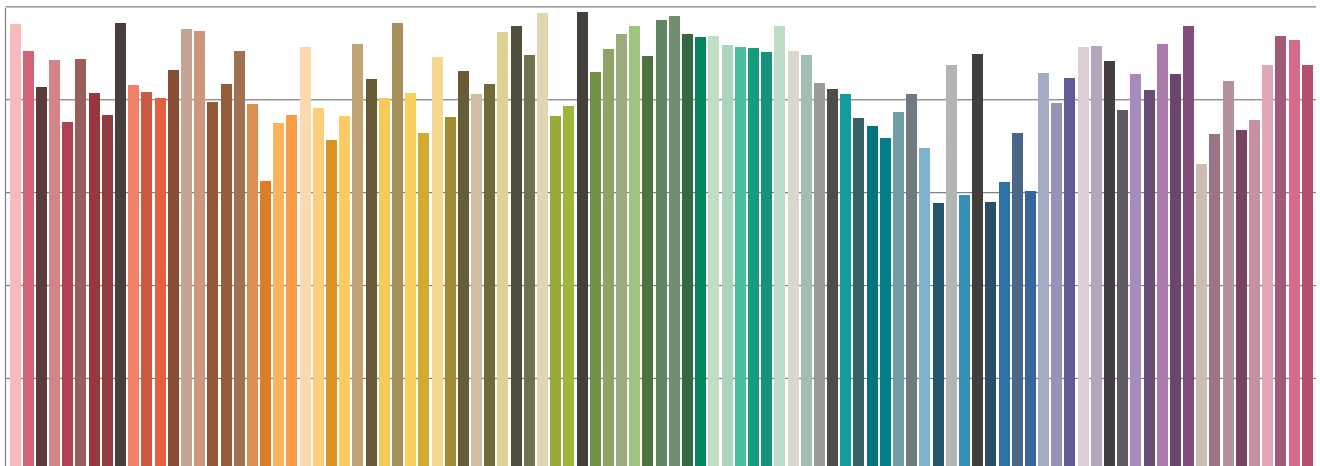

Color Temperature: 5540K

Accuracy Metric Overview

Color Rendering Index	Color Rendering Index, R9 (Red Component)	TM-30 Color Fidelity	TM-30 Color Gamut	Television Lighting Consistency Index	Color Quality Scale	Color Coordinate- CIE 1931	Color Coordinate- CIE 1931	Deviation from Black Body	SSI [CIE A] Tungsten	SSI [CIE D65] Daylight
CRI	CRI R9	TM30 R _f	TM30 R _g	TLCI	CQS	x	Y	Δuv	SSI _t	SSI _d
92.5	65.4	88.9	99.8	90	87.1	0.332	0.329	-0.0058	37	67

CIE 1931

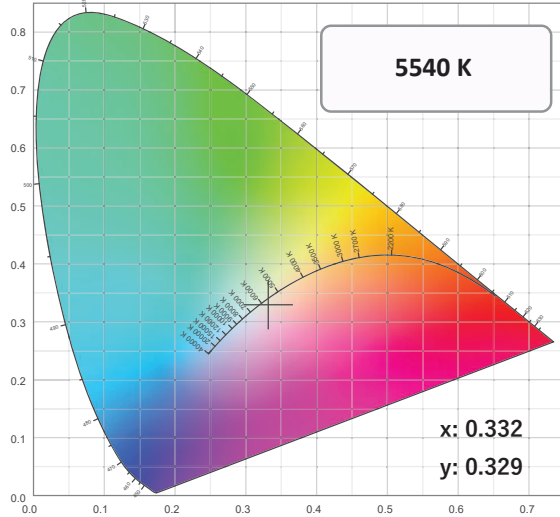

CIE 1931 ZOOMED

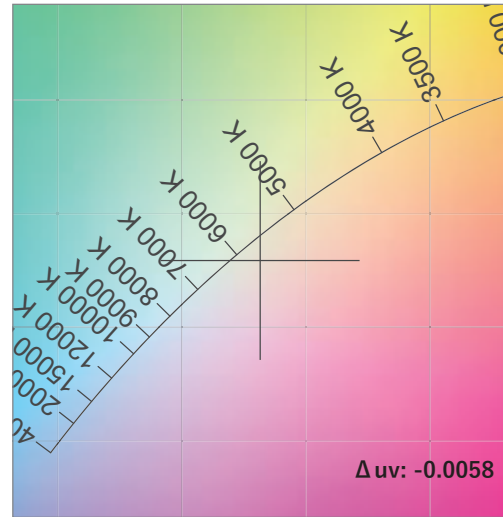

CRI: 92.5 (R1-R8)

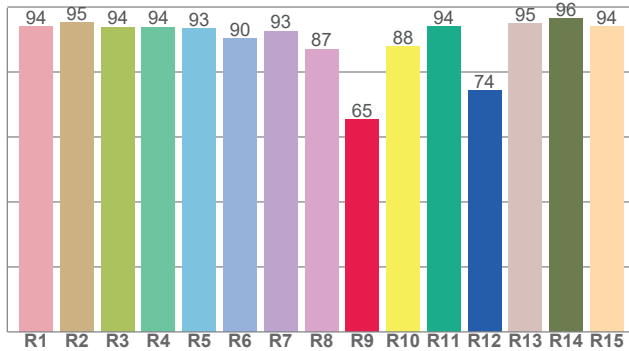

Spectral Power Distribution (SPD)

Dominant Wavelength 610 nm

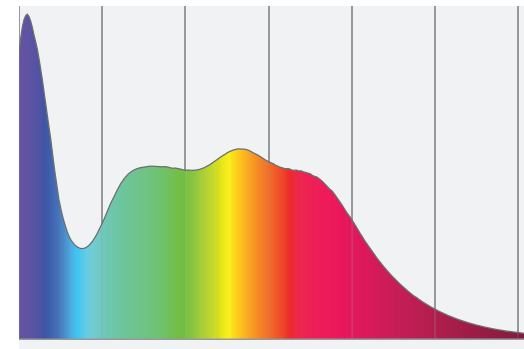

SSI Spectral Variance Graph- Tungsten

SSI [CIE A] 37

Spectral variance

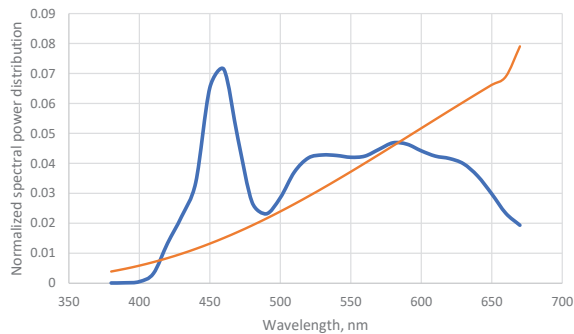

— Test Source — CIE Illuminant A - Tungsten

SSI Spectral Variance Graph- Daylight

SSI [CIE D65] 67

Spectral variance

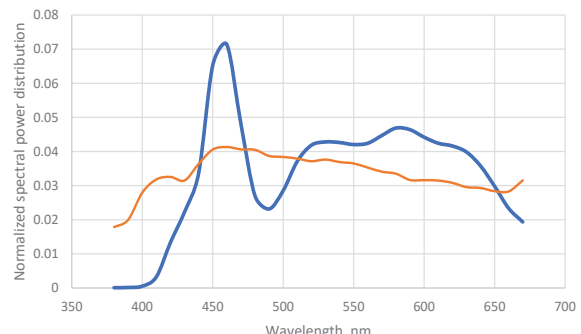

— Test Source — CIE Illuminant D65 - Daylight

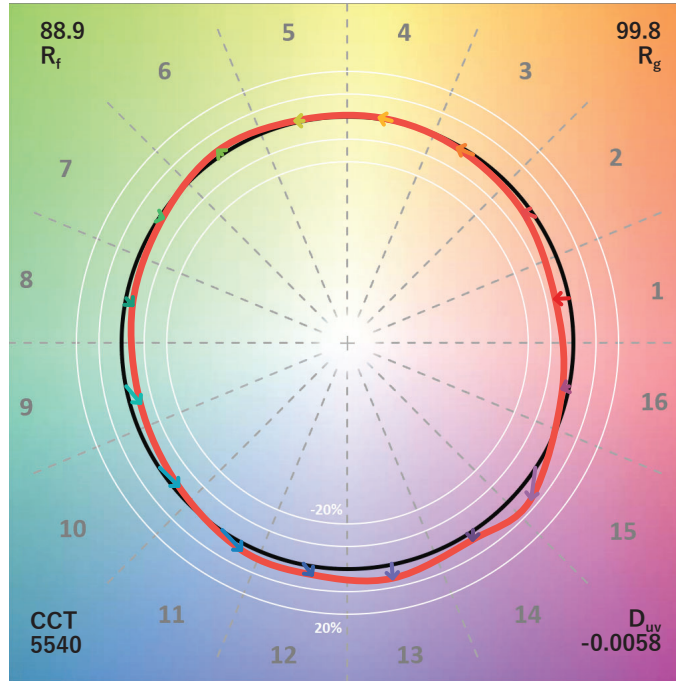

TM30-18 R_f Values per Hue Bin

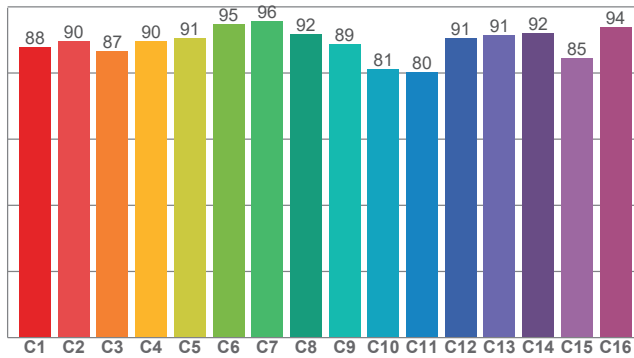

TM30 Chroma Shift per Hue Bin

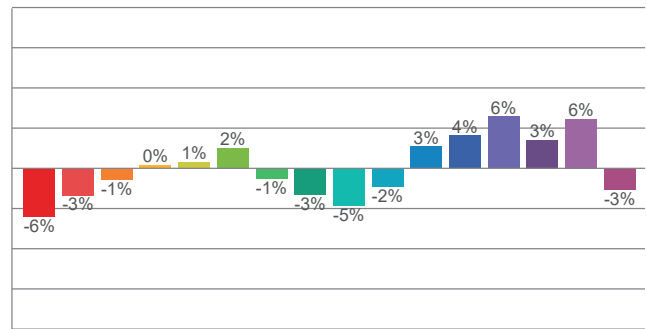

TM30-18 R_f Values per Reference Color (CES)

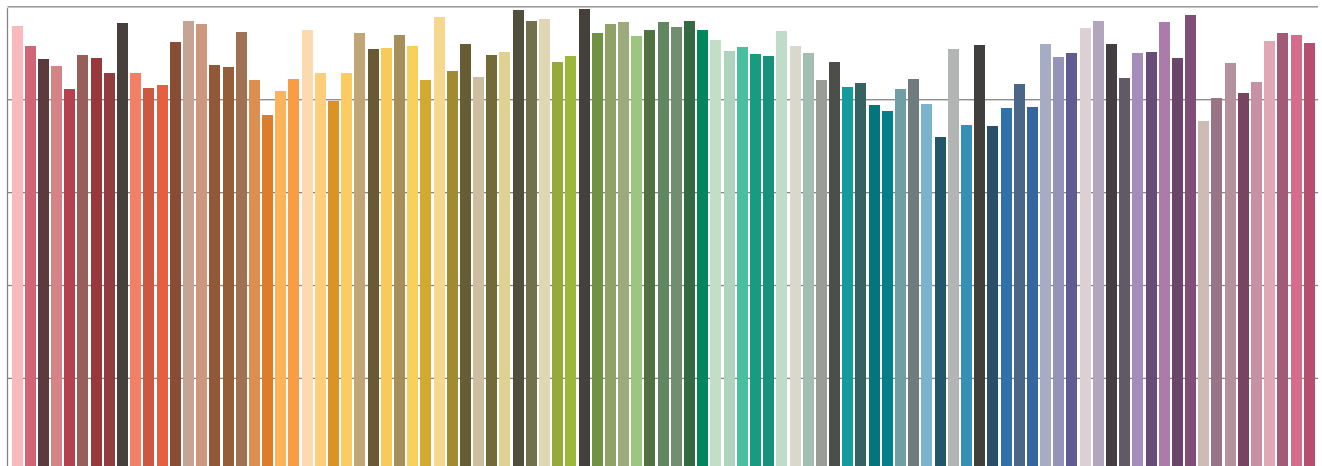

Color Temperature: 2428K

Accuracy Metric Overview

Color Rendering Index	Color Rendering Index, R9 (Red Component)	TM-30 Color Fidelity	TM-30 Color Gamut	Television Lighting Consistency Index	Color Quality Scale	Color Coordinate- CIE 1931	Color Coordinate- CIE 1931	Deviation from Black Body	SSI [CIE A] Tungsten	SSI [CIE D65] Daylight
CRI	CRI R9	TM30 R _f	TM30 R _g	TLCI	CQS	x	Y	Δuv	SSIt	SSId
90.9	77.7	89.2	101.5	67	84.3	0.487	0.419	0.0016	74	25

CIE 1931

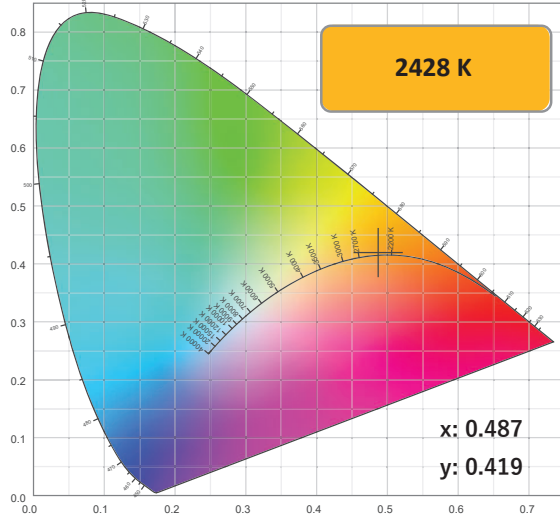

CIE 1931 ZOOMED

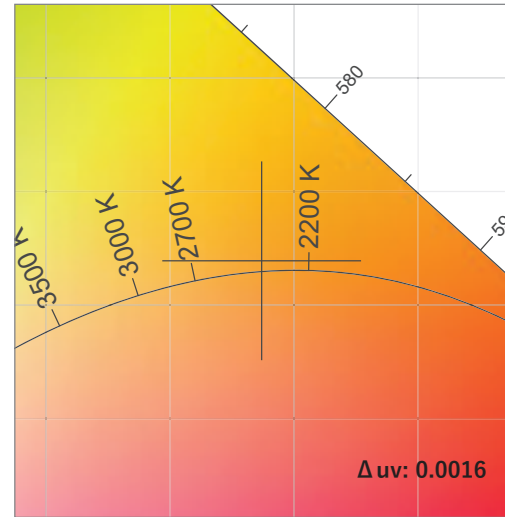

CRI: 90.9 (R1-R8)

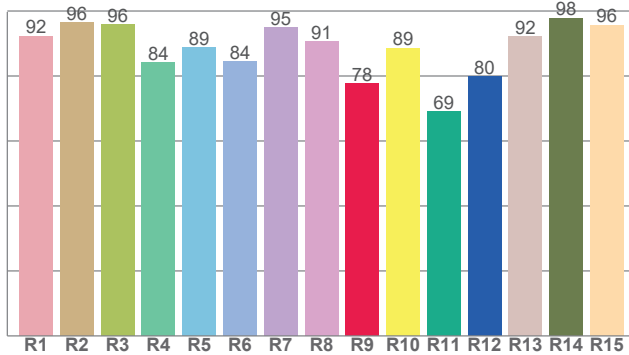

Spectral Power Distribution (SPD)

Dominant Wavelength 586 nm

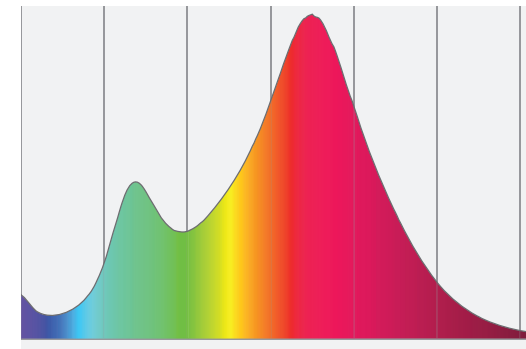

SSI Spectral Variance Graph- Tungsten

SSI [CIE A] 74

Spectral variance

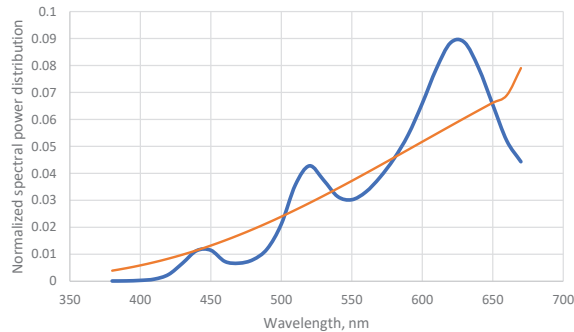

— Test Source — CIE Illuminant A - Tungsten

SSI Spectral Variance Graph- Daylight

SSI [CIE D65] 25

Spectral variance

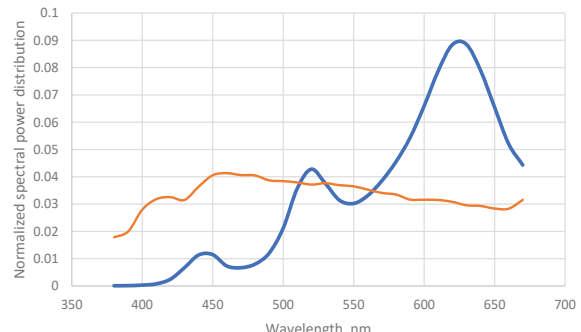

— Test Source — CIE Illuminant D65 - Daylight

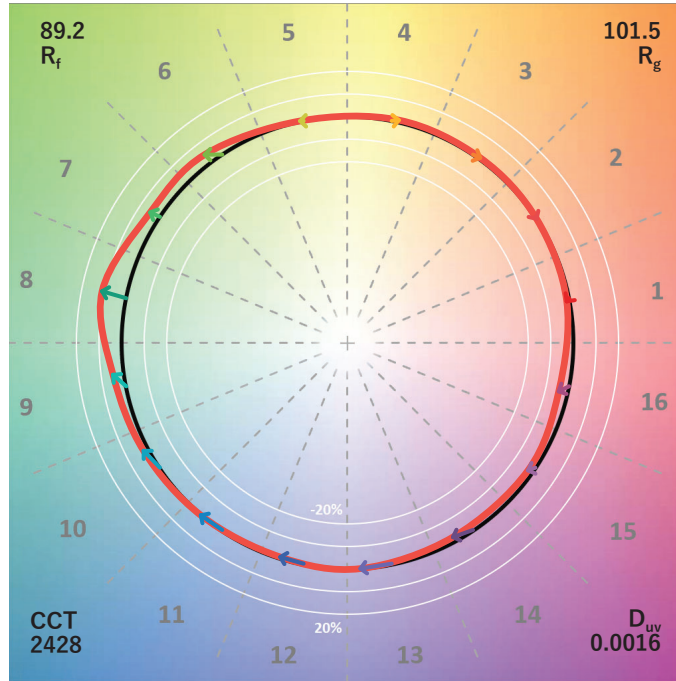

TM30-18 R_f Values per Hue Bin

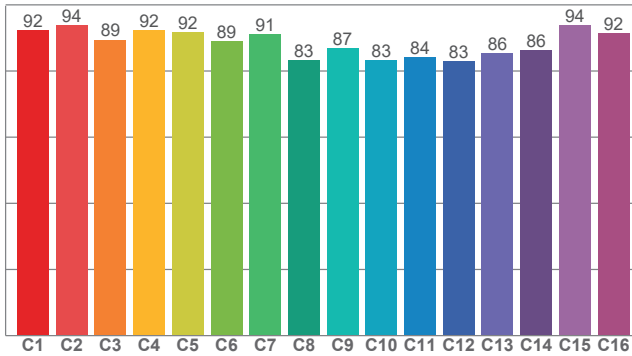

TM30 Chroma Shift per Hue Bin

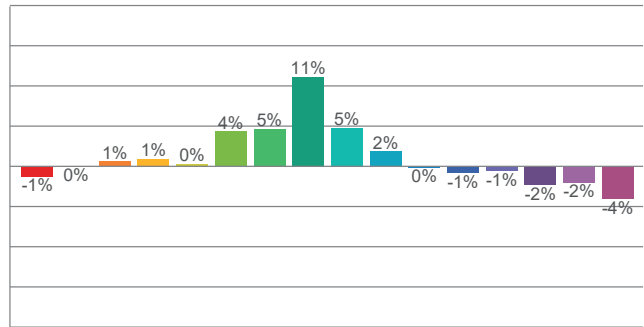

TM30-18 R_f Values per Reference Color (CES)

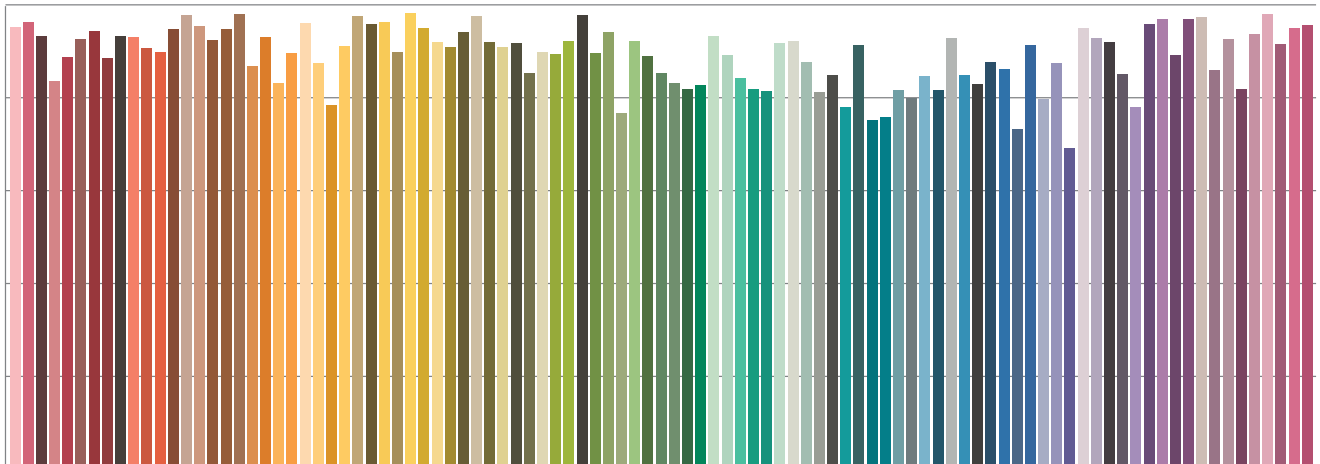

Color Temperature: 2320K

Accuracy Metric Overview

Color Rendering Index	Color Rendering Index, R9 (Red Component)	TM-30 Color Fidelity	TM-30 Color Gamut	Television Lighting Consistency Index	Color Quality Scale	Color Coordinate- CIE 1931	Color Coordinate- CIE 1931	Deviation from Black Body	SSI [CIE A] Tungsten	SSI [CIE D65] Daylight
CRI	CRI R9	TM30 R _f	TM30 R _g	TLCI	CQS	x	Y	Δuv	SSIt	SSId
89.1	96.8	87.7	103.9	66	84.2	0.491	0.411	-0.0014	76	24

CIE 1931

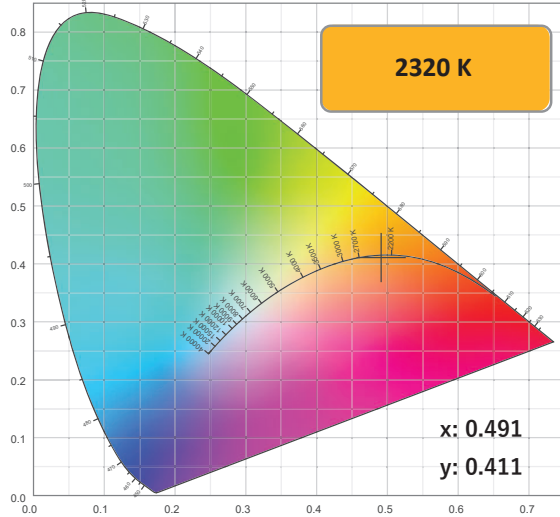

CIE 1931 ZOOMED

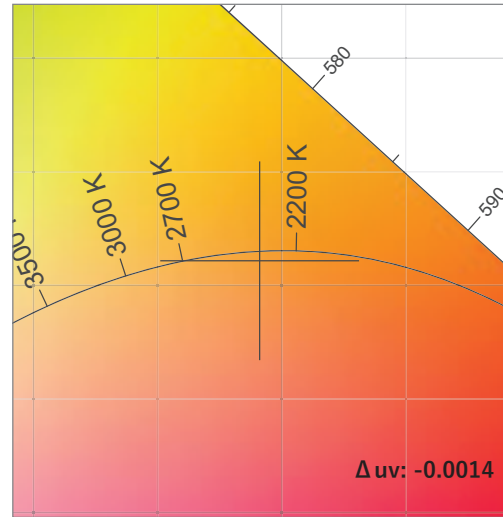

CRI: 89.1 (R1-R8)

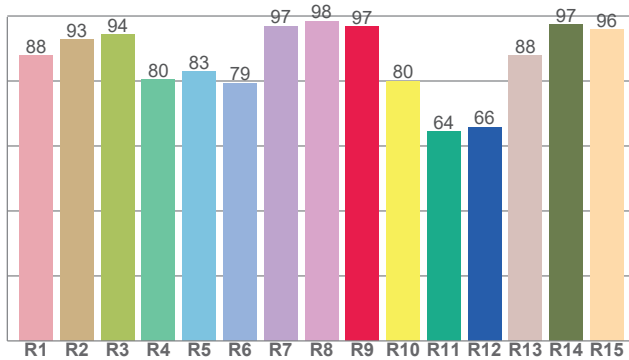

Spectral Power Distribution (SPD)

Dominant Wavelength 587 nm

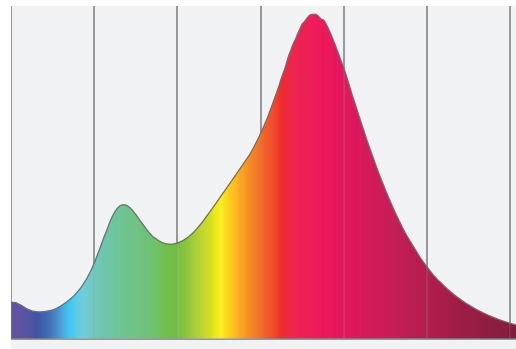

SSI Spectral Variance Graph- Tungsten

SSI [CIE A] 76

Spectral variance

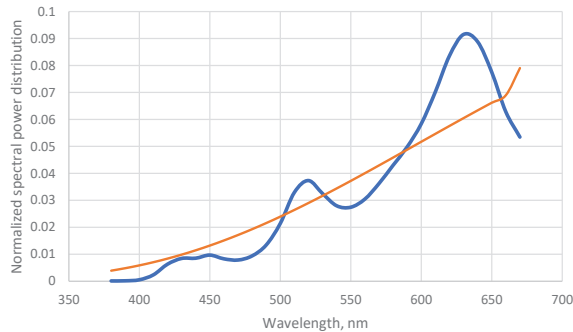

— Test Source — CIE Illuminant A - Tungsten

SSI Spectral Variance Graph- Daylight

SSI [CIE D65] 24

Spectral variance

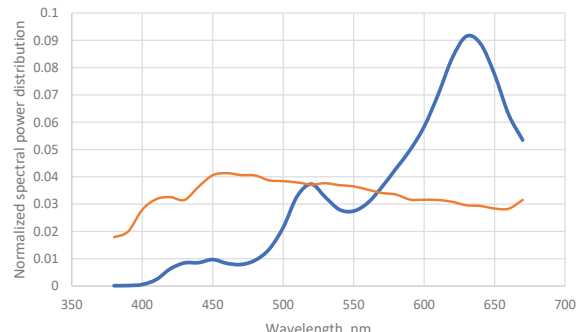

— Test Source — CIE Illuminant D65 - Daylight

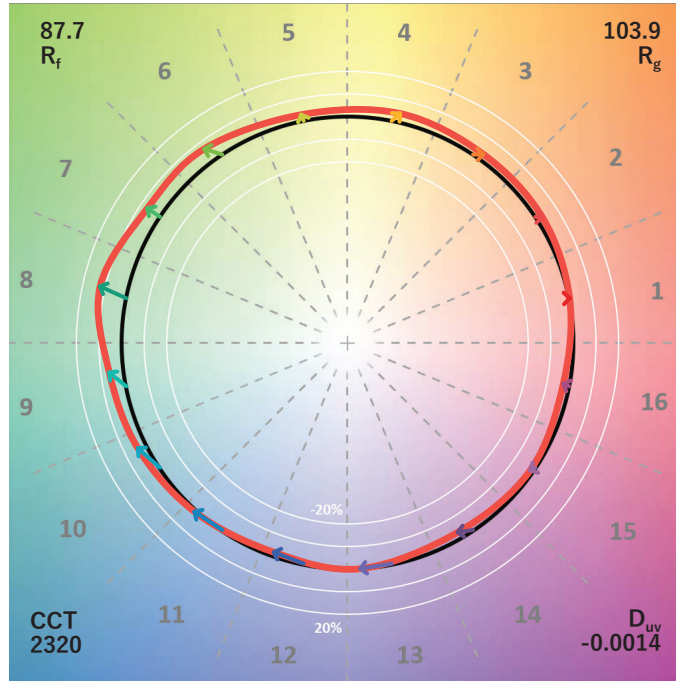

TM30-18 R_f Values per Hue Bin

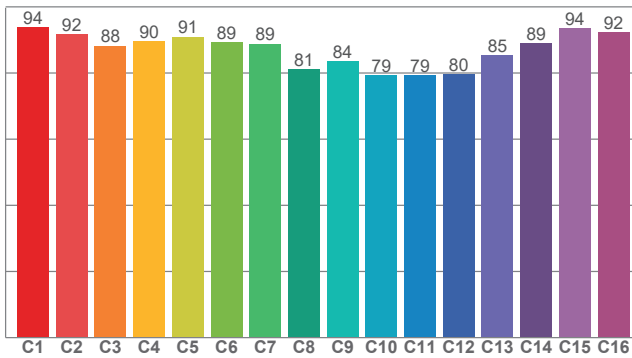

TM30 Chroma Shift per Hue Bin

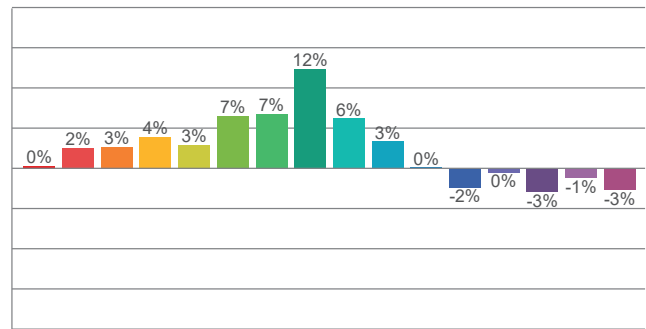

TM30-18 R_f Values per Reference Color (CES)

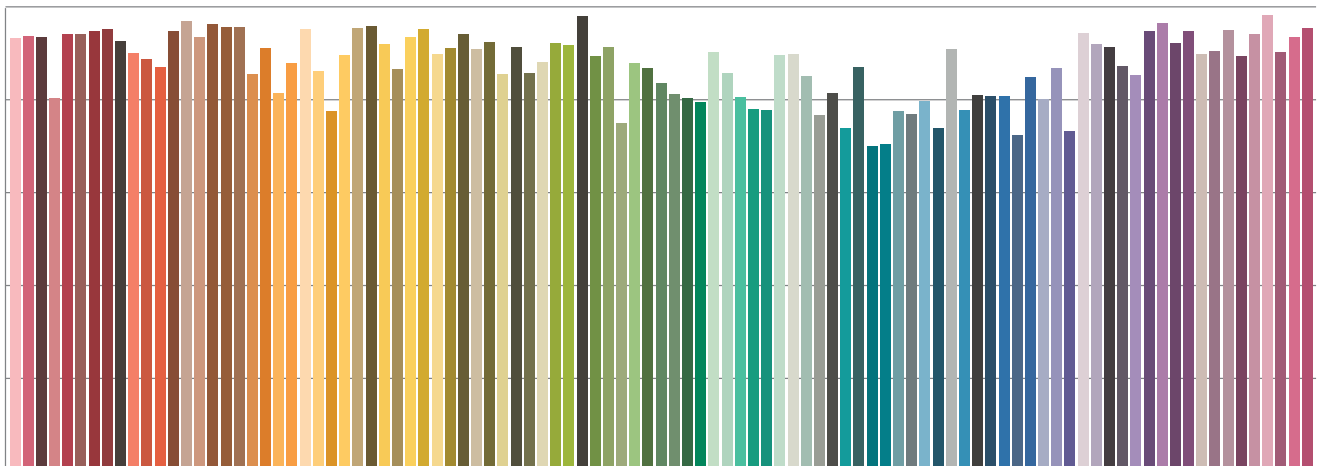

Measurements

Total Lumen Output: 3140 lm
 Peak Intensity: 48876 cd
 Efficacy: 4 Lumen/Watt
 Power: 769.8 W
 Voltage: 230 V, Current: 3.36 A

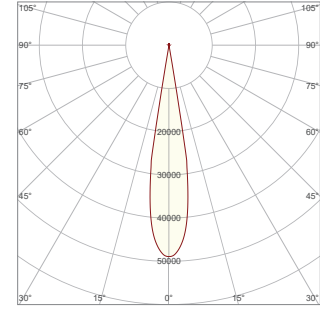

Spectral Power Distribution

Dominant Wavelength 473 nm

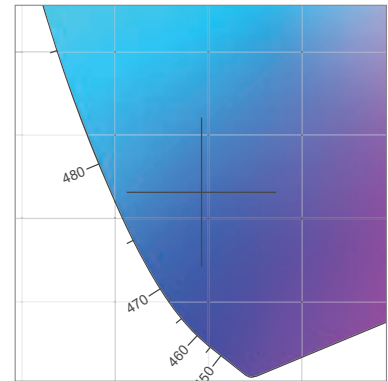
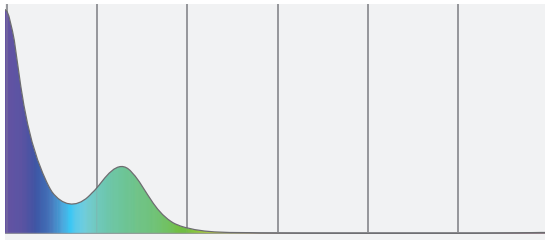

Dominant Wavelength	Color Coordinate CIE 1931	Color Coordinate CIE1931	Color Coordinate CIE 1964	Color Coordinate CIE 1964
nm	x	y	u	v
473	0.146	0.116	0.143	0.169

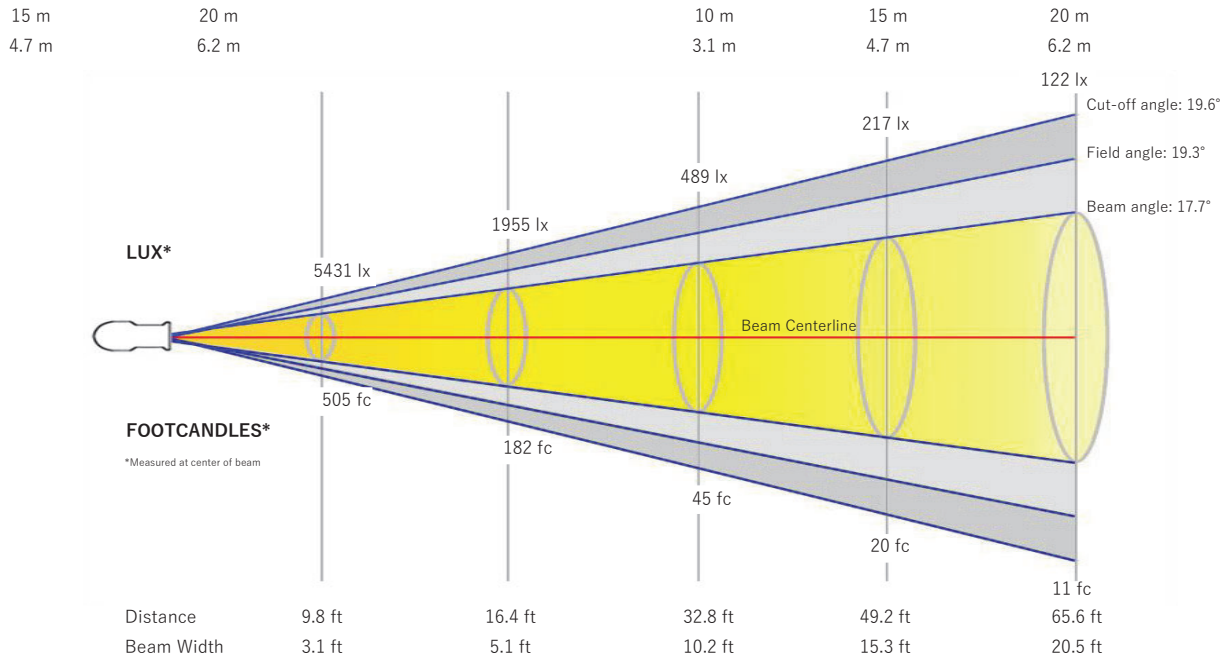

Beam Intensities from 1-20m

M	1	2	3	4	5	6	7	8	9	10	11	12	13	14	15	16	17	18	19	20
FT	3.3	6.6	9.8	13.1	16.4	19.7	23	26.2	29.5	32.8	36.1	39.4	42.7	45.9	49.2	52.5	55.8	59.1	62.3	65.6
LX	48876	12219	5431	3055	1955	1358	997	764	603	489	404	339	289	249	217	191	169	151	135	122
FC	4540.7	1135.2	504.5	283.8	181.6	126.1	92.7	70.9	56.1	45.4	37.5	31.5	26.9	23.2	20.2	17.7	15.7	14	12.6	11.4

Measurements

Total Lumen Output: 1240 lm
 Peak Intensity: 20351 cd
 Efficacy: 2 Lumen/Watt
 Power: 755.1 W
 Voltage: 229 V, Current: 3.31 A

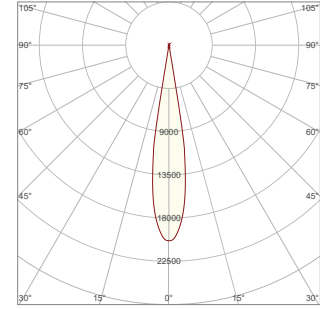
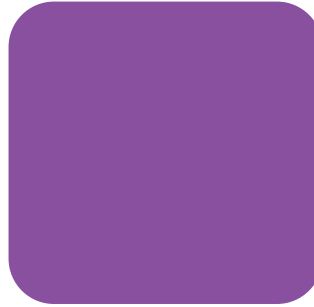

Spectral Power Distribution

Dominant Wavelength 561 nm

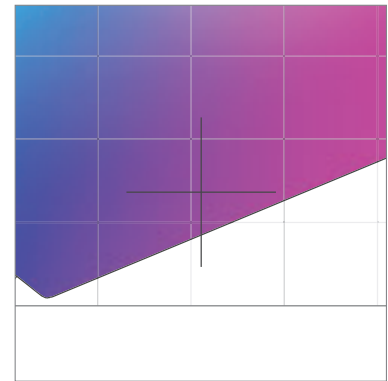
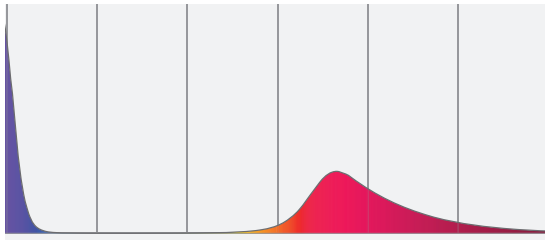

Dominant Wavelength	Color Coordinate CIE 1931	Color Coordinate CIE1931	Color Coordinate CIE 1964	Color Coordinate CIE 1964
nm	x	y	u	v
561	0.255	0.068	0.309	0.124

15 m
4.6 m

20 m
6.1 m

10 m
3 m

15 m
4.6 m

20 m
6.1 m

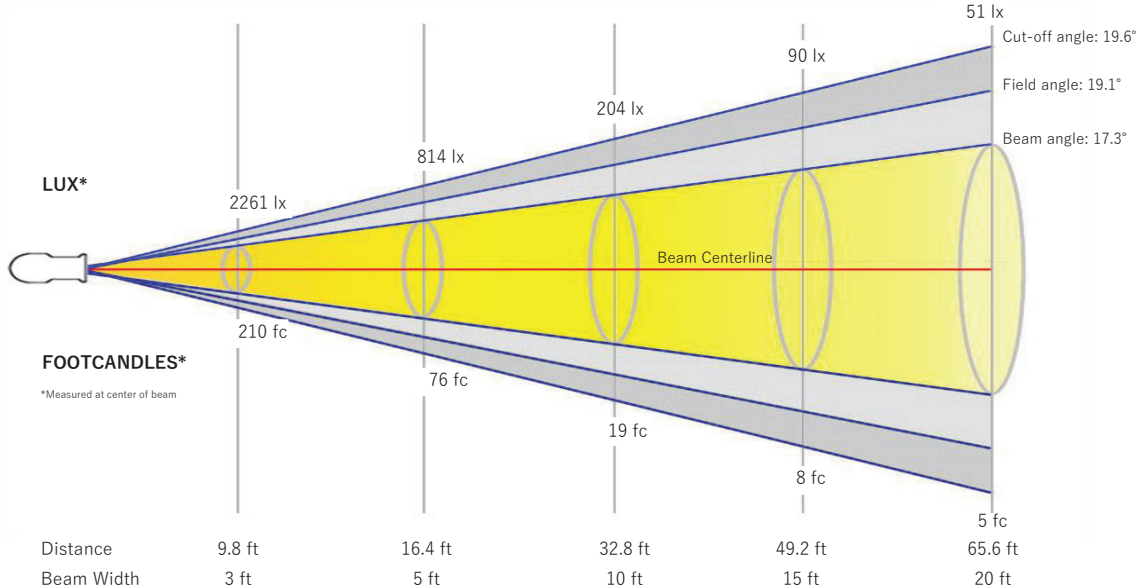

Beam Intensities from 1-20m

M	1	2	3	4	5	6	7	8	9	10	11	12	13	14	15	16	17	18	19	20
FT	3.3	6.6	9.8	13.1	16.4	19.7	23	26.2	29.5	32.8	36.1	39.4	42.7	45.9	49.2	52.5	55.8	59.1	62.3	65.6
LX	20351	5088	2261	1272	814	565	415	318	251	204	168	141	120	104	90	79	70	63	56	51
FC	1890.7	472.7	210.1	118.2	75.6	52.5	38.6	29.5	23.3	18.9	15.6	13.1	11.2	9.6	8.4	7.4	6.5	5.8	5.2	4.7

Measurements

Total Lumen Output: 14913 lm
 Peak Intensity: 237425 cd
 Efficacy: 19 Lumen/Watt
 Power: 769.5 W
 Voltage: 230 V, Current: 3.37 A

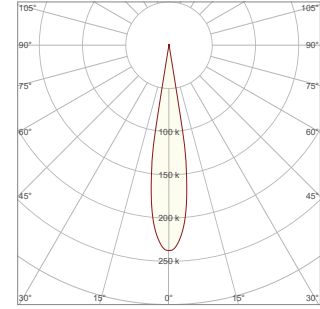
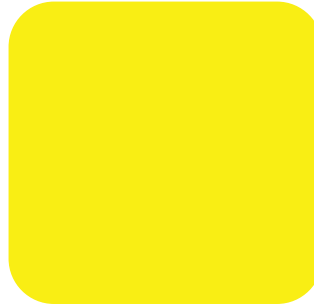

Spectral Power Distribution

Dominant Wavelength 576 nm

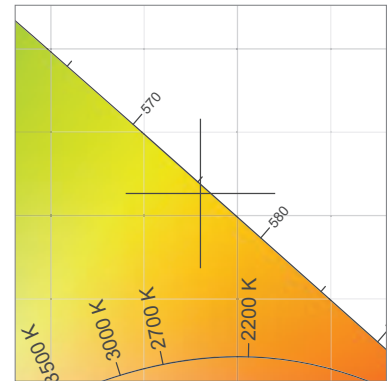
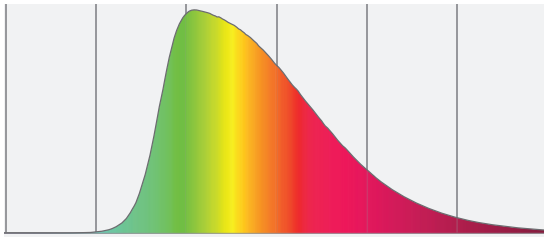

Dominant Wavelength	Color Coordinate CIE 1931	Color Coordinate CIE1931	Color Coordinate CIE 1964	Color Coordinate CIE 1964
nm	x	y	u	v
576	0.480	0.513	0.234	0.376

15 m
4.6 m

20 m
6.1 m

10 m
3.1 m

15 m
4.6 m

20 m
6.1 m

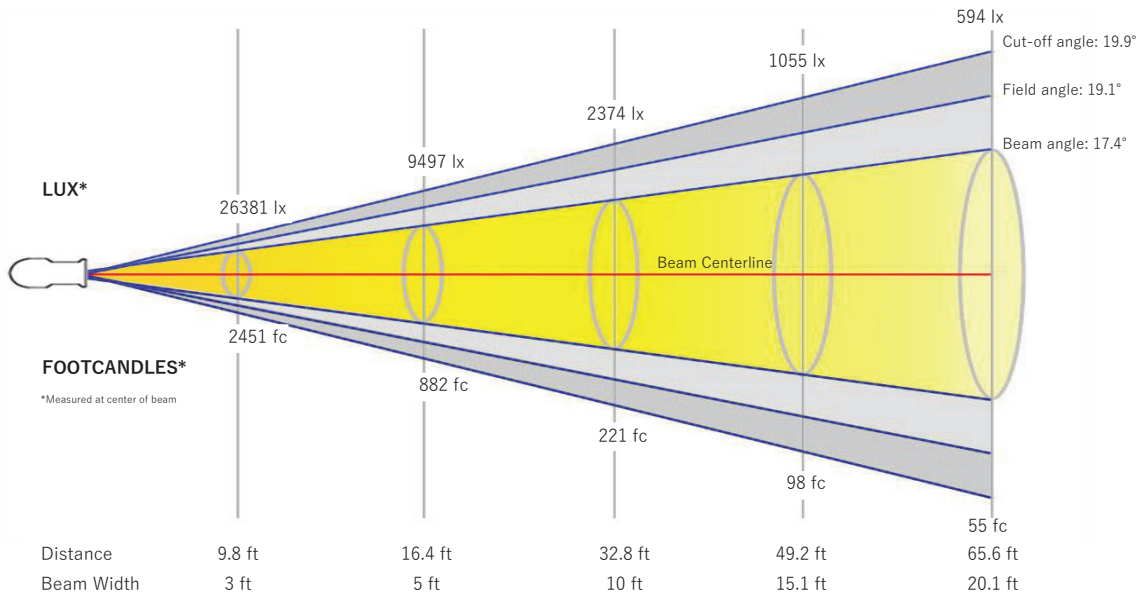

Beam Intensities from 1-20m

M	1	2	3	4	5	6	7	8	9	10	11	12	13	14	15	16	17	18	19	20
FT	3.3	6.6	9.8	13.1	16.4	19.7	23	26.2	29.5	32.8	36.1	39.4	42.7	45.9	49.2	52.5	55.8	59.1	62.3	65.6
LX	237425	59356	26381	14839	9497	6595	4845	3710	2931	2374	1962	1649	1405	1211	1055	927	822	733	658	594
FC	22057.5	5514.4	2450.8	1378.6	882.3	612.7	450.2	344.6	272.3	220.6	182.3	153.2	130.5	112.5	98	86.2	76.3	68.1	61.1	55.1