

# Javelin Service Manual

---

After Service Department  
Version: V3.0  
Date: 2022.01.11

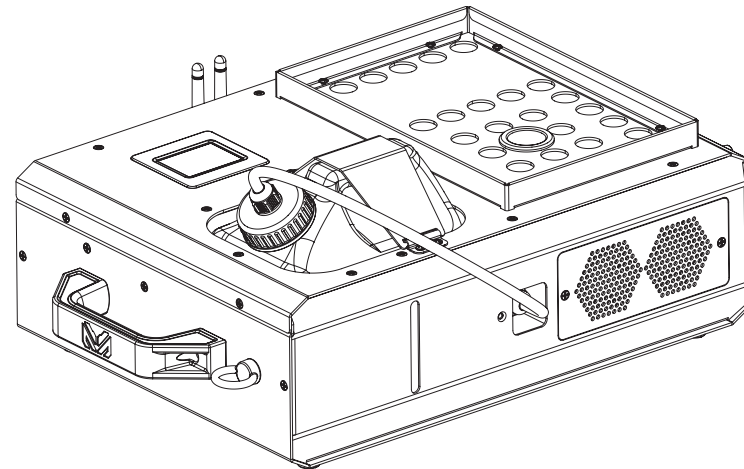

# Javelin



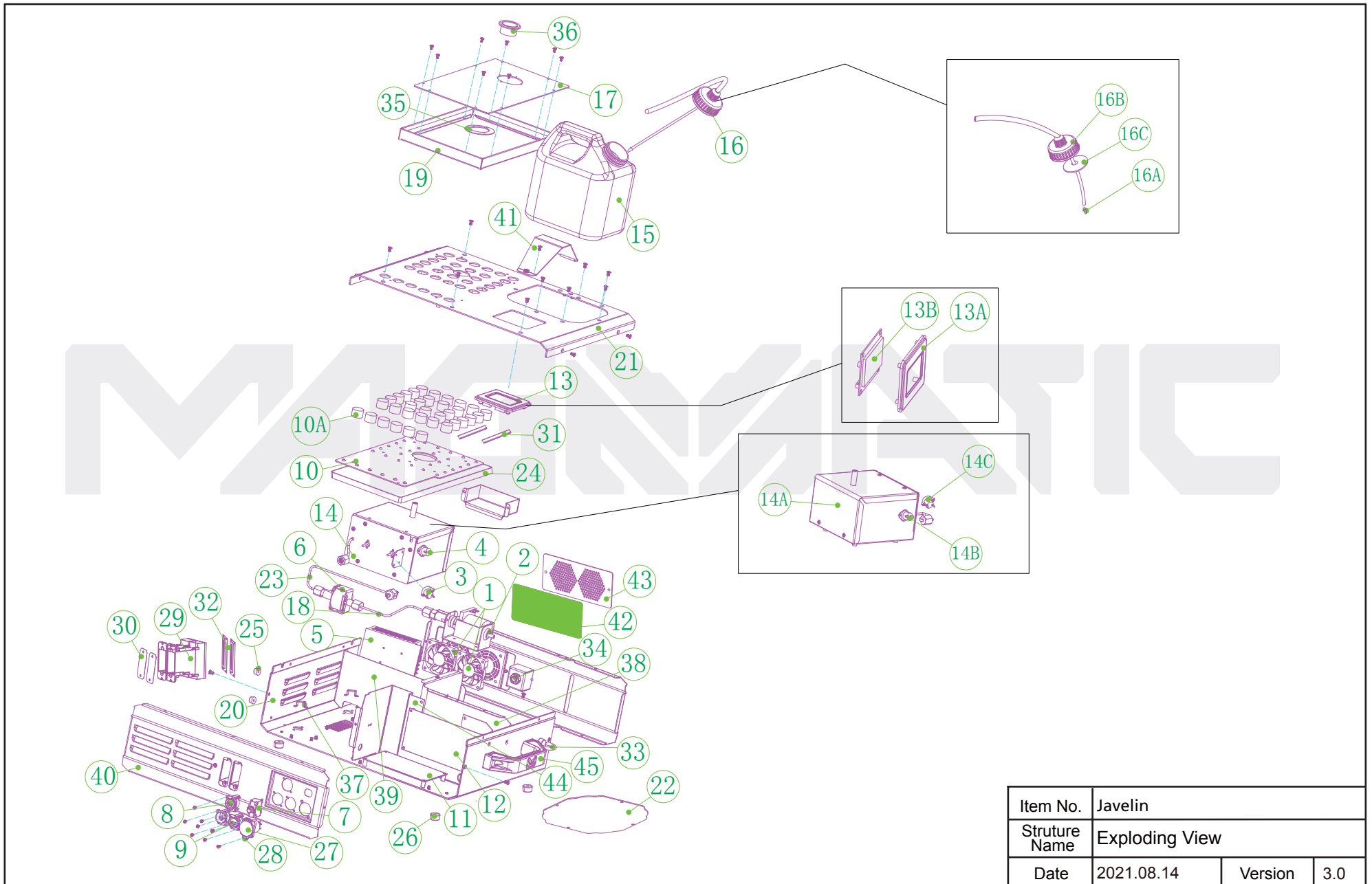

## Service Manual Contents

---

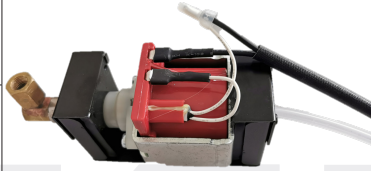

- Exploding View ..... 1
- Wiring diagram ..... 11
- Circuitry of The PCB ..... 12





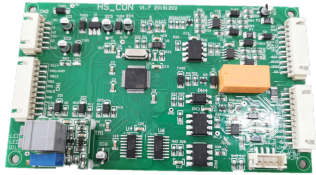
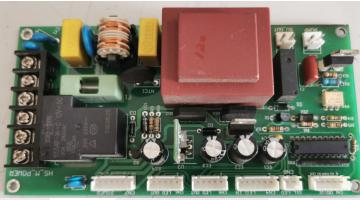

Item No.	Javelin		
Structure Name	Exploding View		
Date	2021.08.14	Version	3.0

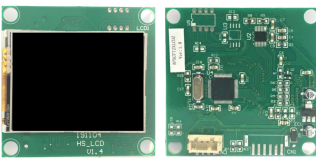



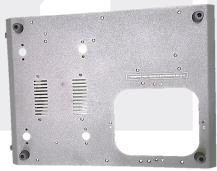

ET item no.	ET2 item no.	Exploded drawing number	photo	Item no.	Description
		1		TIXFD06015BZ	Fan for Javelin
		2		AAXCF92DCBMG	Electromagnetic pump assembly for Javelin (120V)
		2		AAXCF92DCBOG	Electromagnetic pump assembly for Javelin (230V)
		3		SHX250V10AZZ	250 degree temperature protection manual reset switch 180 degree angle (250V 10A) for Javelin
		4		SHX220X180ZZ	220 degree temperature protection manual reset switch 180 degree angle (250V 10A) for Javelin
		5		SAXDC15V120V	Switching power supply for Javelin

ET item no.	ET2 item no.	Exploded drawing number	photo	Item no.	Description
		6		ABXDCCFCP120Z	Electric magnetic valve assembly for Javelin (120V)
		6		ABXDCCFCPZZZZ	Electric magnetic valve assembly for Javelin (230V)
		7		SKX20AX180CZ	No fuse switch 20A-180 degree straight foot for Javelin (120V)
		7		SKX10AX180CZ	No fuse switch 10A-180 degree straight foot for Javelin (230V)
		8		APXFN22X110Z	4Pin Female XLR Connector PCB(DMX-SF-4P) for Javelin
		9		APXFN22DMXBZ	5Pin Male/Female Connector PCB (DMX-SF-5P) for Javelin
		10		APXLIGHTXZZZ	LED PCB for Javelin
		10A		NBX3WXBX10CZ	3W lens with black positioning sheath around for Javelin

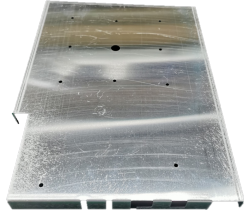
ET item no.	ET2 item no.	Exploded drawing number	photo	Item no.	Description
		11		APXCF92ZZZZZ	Main control PCB for Javelin
		12		APXHSXMPower	Power PCB for Javelin (120V)
		12		APXHSXM230ZZ	Power PCB for Javelin (230V)
		13		ABXCF92XZZZZ	Finished display board assembly for Javelin
		13A		FBXFZ22XYSHZ	Touch screen base for Javelin
		13B		APXCF92XLCDZ	Display PCB for Javelin



ET item no.	ET2 item no.	Exploded drawing number	photo	Item no.	Description
		14		ABXCF92ETDZU	Heaterblock for Javelin (120V)
		14		ABXCF92ETDZW	Heaterblock for Javelin (230V)
		14A		ABXCF92BDDZU	Heaterblock for Javelin (120V)(without temperature switch)
		14A		ABXCF92BDDZW	Heaterblock for Javelin (230V)(without temperature switch)
		15		WDXCF700XD1Z	Liquid Tank (W/O Cap) for Javelin
		16		ABXCF92XLDZW	Oil tank cap assembly for Javelin
		16A		NBXM5X00001Z	M5 Thread Filter for Javelin
		16B		WHXAF1200XWZ	Oil tank cap for Javelin
		16C		WHXCF1500XD1	Gasket for Javelin

ET item no.	ET2 item no.	Exploded drawing number	photo	Item no.	Description
		17		WLXCF92B001Z	LED transparent cover for Javelin
		18		WHX200MMZZZZ	High pressure oil pipe for Javelin
		19		FBXCF92A001Z	Light guard frame for Javelin
		20		FBXCF92A07ZZ	Base cover for Javelin
		21		FBXCF92A08ZZ	Upper cover for Javelin
		22		FBXCF92A009Z	Liquid Tank bottom cover for Javelin
		23		AAXCF92HYGZZ	Oil return pipe connection assembly for Javelin

ET item no.	ET2 item no.	Exploded drawing number	photo	Item no.	Description
		24		EXCF92XA018Z	Cover for Javelin
		25		WJX15X7ZZZZZ	Foot pad for Javelin
		26		WJX18X13X10Z	Foot pad for Javelin
		27		EAXSAC3MPLYZ	Waterproof power plug socket POWERCON female for Javelin
		28		WHXFZ22XCNAC	Power socket waterproof pad for Javelin
		29		EXFN22D007ZZ	Wireless slot base for Javelin

ET item no.	ET2 item no.	Exploded drawing number	photo	Item no.	Description
		30		EXFZ22XA010Z	Wireless slot shielding surface for Javelin
		31		EXCF72XA018Z	Display fixed metal piece for Javelin
		32		APXSKT805XBZ	Finished PCB board SKT_805 for Javelin
		33		QKXM8AZZZZZ	Stainless steel safety ring (black) M8 (male) for Javelin
		34		OA10XMG16AZZ	MG16A waterproof connector (locking iron) for Javelin
		35		NBXCF72D001Z	Spout seal for Javelin

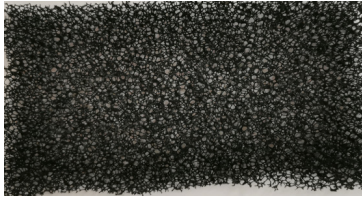
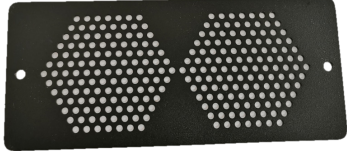
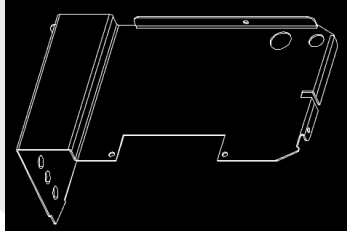
ET item no.	ET2 item no.	Exploded drawing number	photo	Item no.	Description
		36		NBXCF72B002Z	Spout guard for Javelin
		37		FBXRJ30A44ZA	Hook safety baffle for Javelin
		38		FBXCF92F003Z	Oil drum coaming for Javelin
		39		FBXCF92A015Z	Switching power supply fixing plate for Javelin
		40		FBXCF92F001Z	Left side bezel for Javelin
		41		FBXCF92A12ZZ	Tank baffle for Javelin

ET item no.	ET2 item no.	Exploded drawing number	photo	Item no.	Description
		42		YGXFCMMD25ZZ	Fan dustproof cotton for Javelin
		43		EXCF92A016ZZ	Fan cover for Javelin
		44		FBXCF92A013Z	PCB separator for Javelin
		45		AAXCF92WBBMG	Handle assembly for Javelin

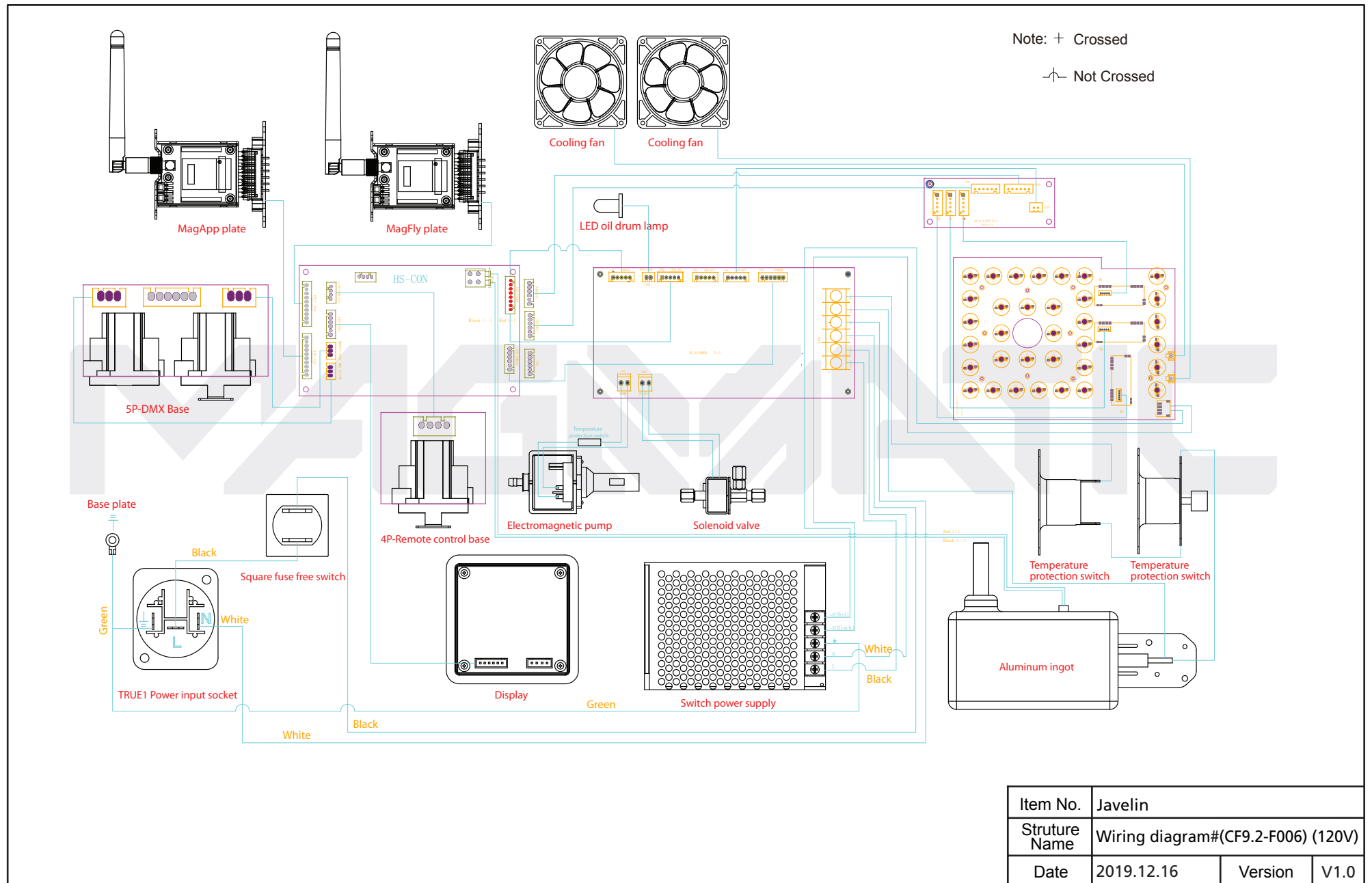

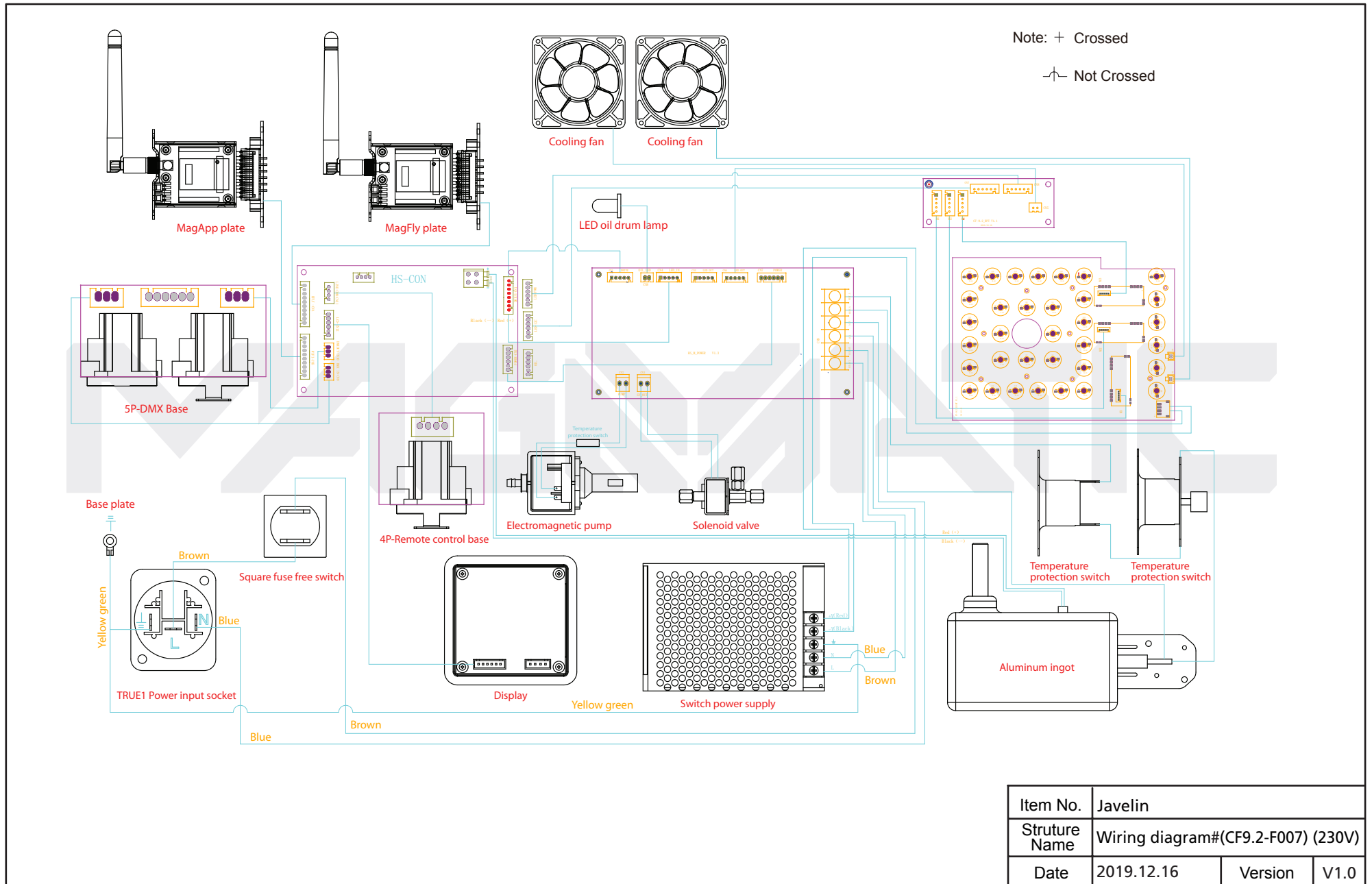

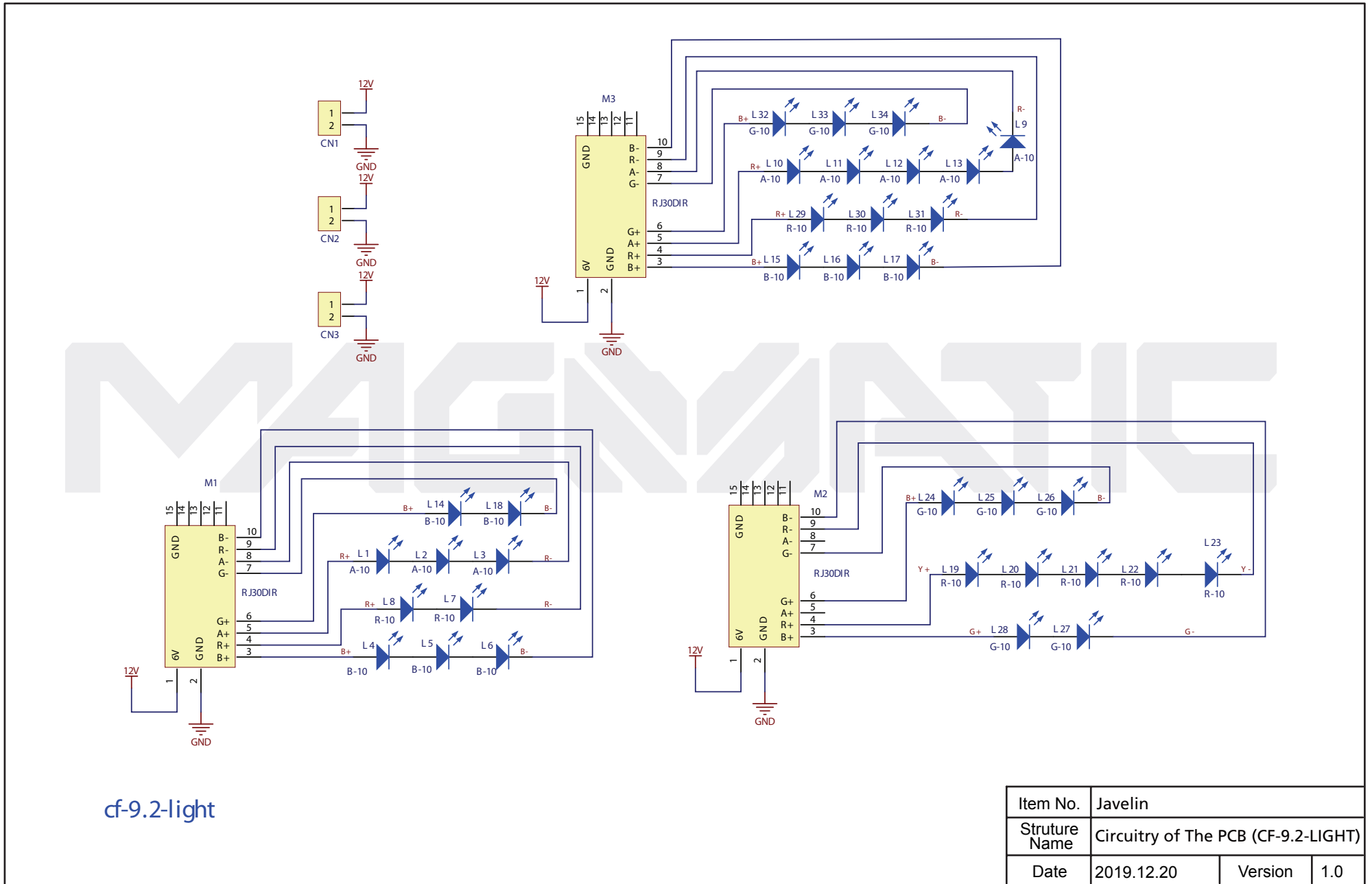

cf-9.2-light

Item No.	Javelin		
Structure Name	Circuitry of The PCB (CF-9.2-LIGHT)		
Date	2019.12.20	Version	1.0

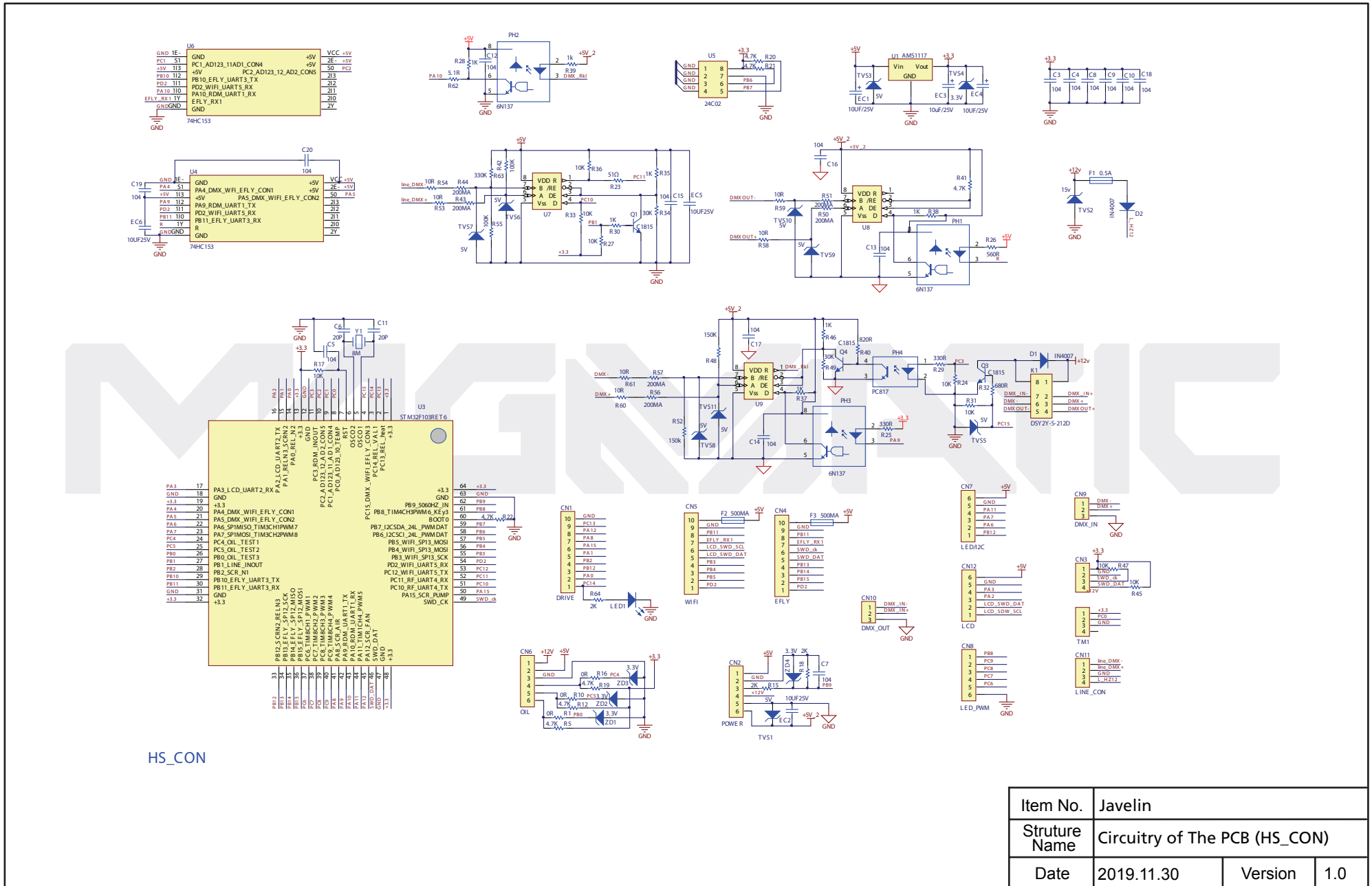

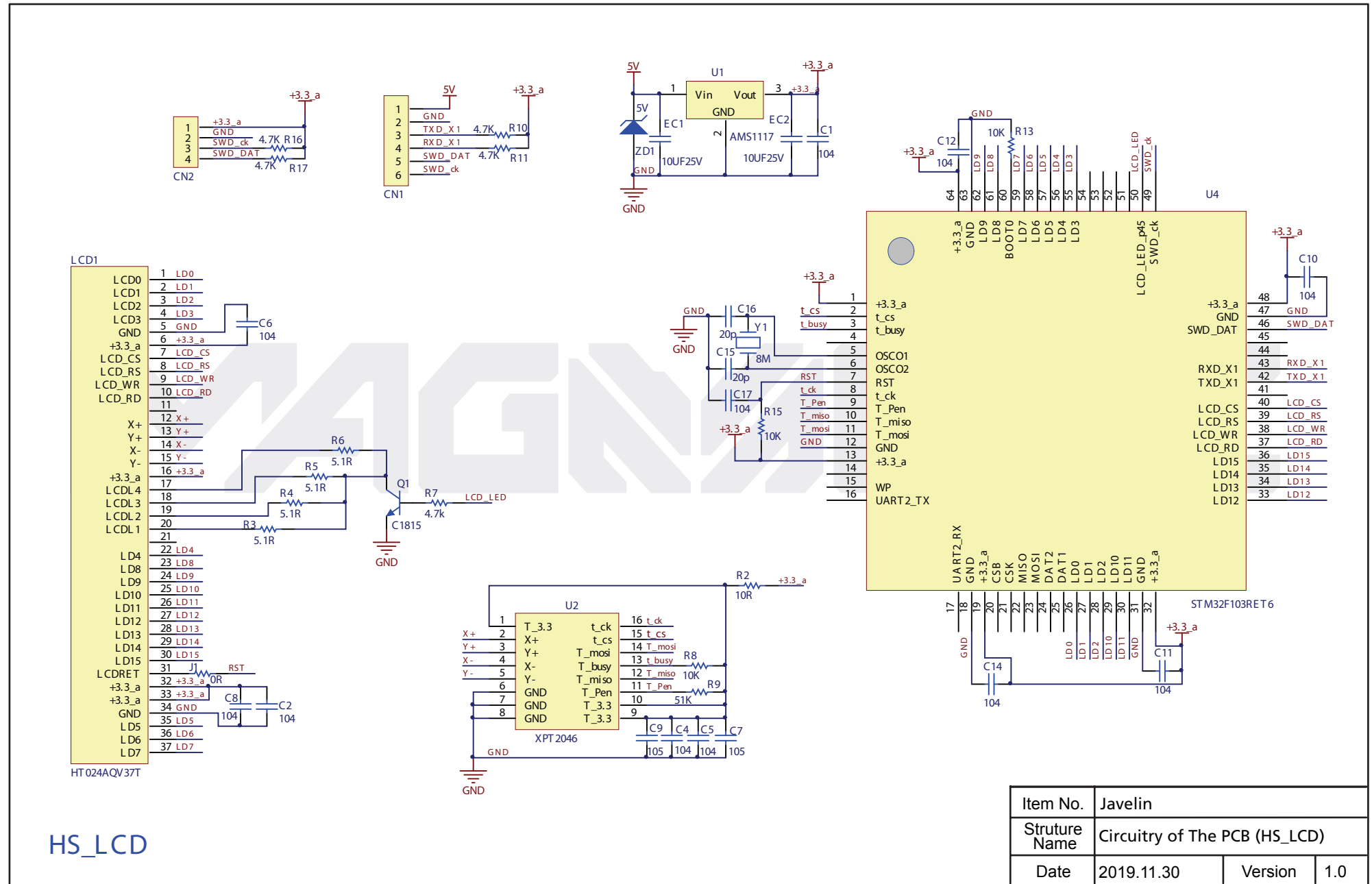

Item No.	Javelin		
Struture Name	Circuitry of The PCB (HS_LCD)		
Date	2019.11.30	Version	1.0

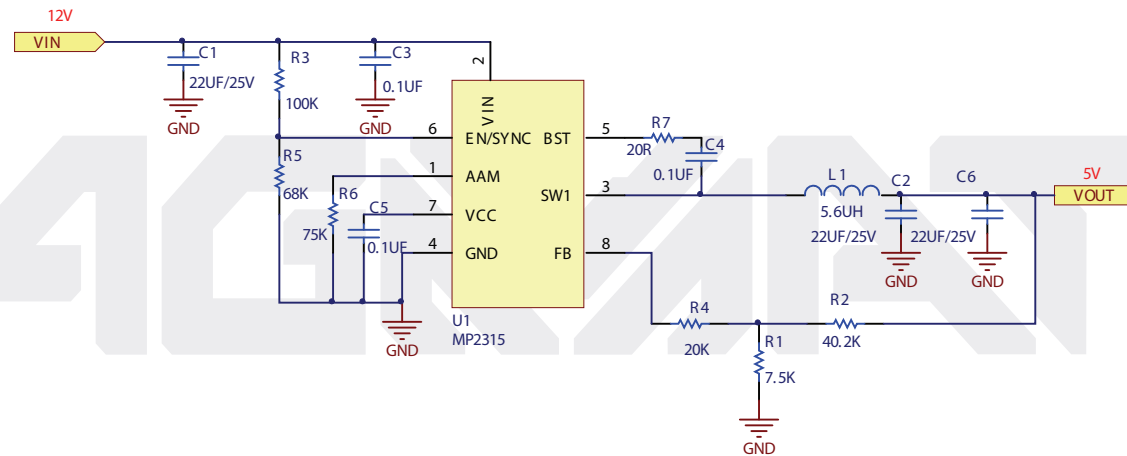

## HS\_SMP

Item No.	Javelin		
Struture Name	Circuitry of The PCB (HS_SMP)		
Date	2019.11.30	Version	1.0

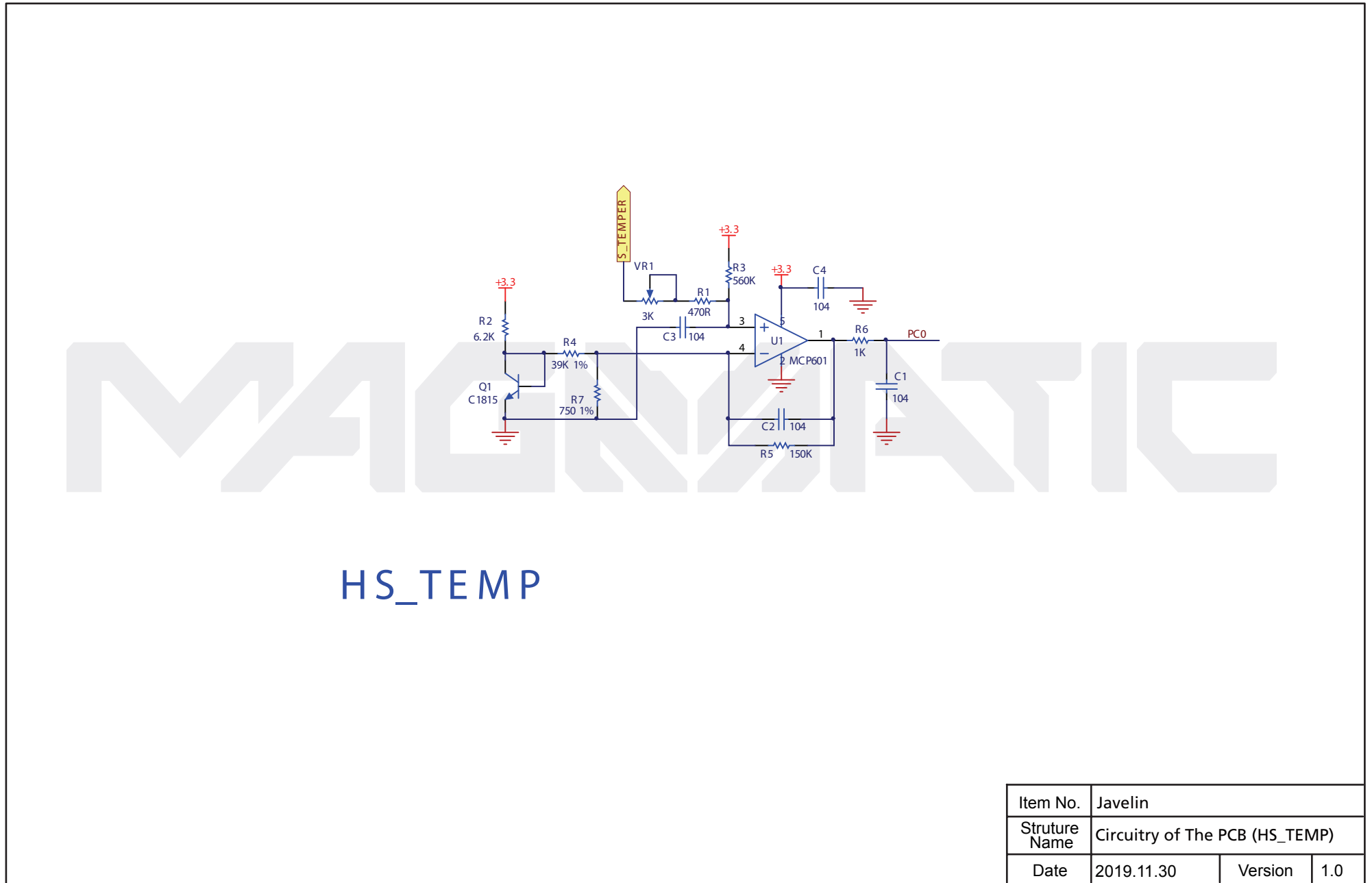

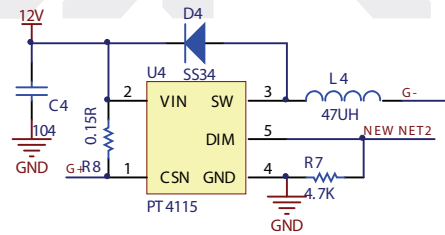
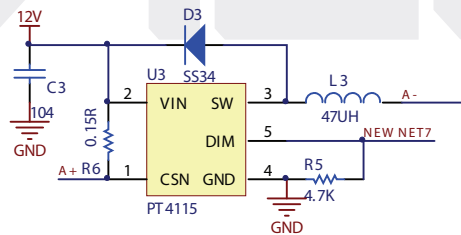
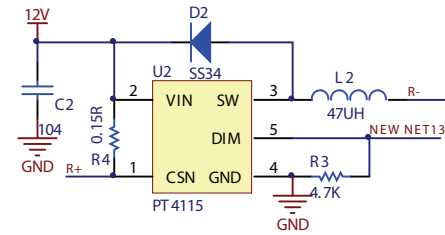
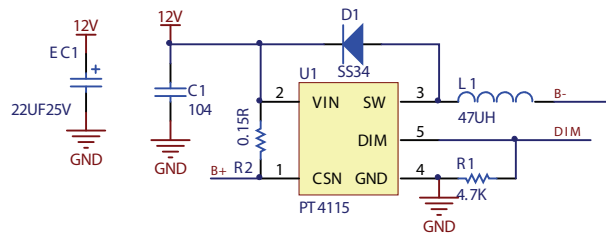

CN1	
1	GND
2	DIM
3	NEW NET14
4	NEW NET8
5	NEW NET3

MAGMATIC

RJ30DIR

Item No.	Javelin		
Struture Name	Circuitry of The PCB (RJ30DIR)		
Date	2019.12.19	Version	1.0