

ELATION®

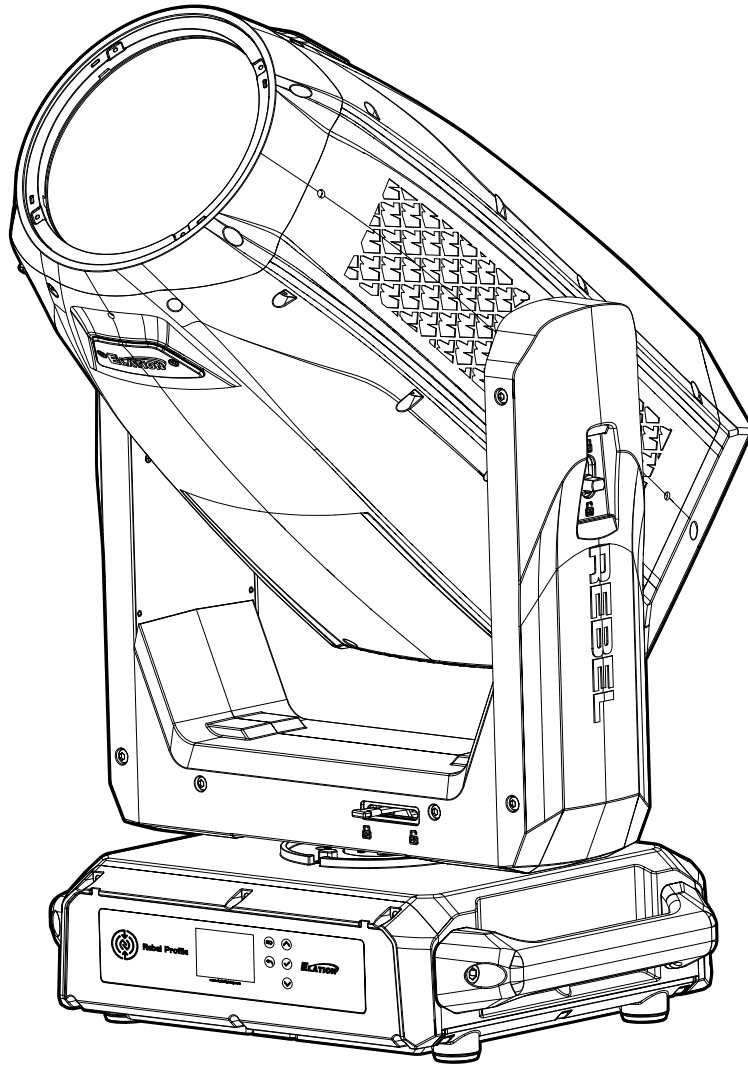

REBEL™ PROFILE
user manual

©2026 ELATION PROFESSIONAL all rights reserved. Information, specifications, diagrams, images, and instructions herein are subject to change without notice. ELATION PROFESSIONAL logo and identifying product names and numbers herein are trademarks of ELATION PROFESSIONAL. Copyright protection claimed includes all forms and matters of copyrightable materials and information now allowed by statutory or judicial law or hereinafter granted. Product names used in this document may be trademarks or registered trademarks of their respective companies and are hereby acknowledged. All non-ELATION brands and product names are trademarks or registered trademarks of their respective companies.

ELATION PROFESSIONAL and all affiliated companies hereby disclaim any and all liabilities for property, equipment, building, and electrical damages, injuries to any persons, and direct or indirect economic loss associated with the use or reliance of any information contained within this document, and/or as a result of the improper, unsafe, insufficient and negligent assembly, installation, rigging, and operation of this product.

Elation Professional USA | 6122 S. Eastern Ave. | Los Angeles, CA. 90040

323-582-3322 | www.elationlighting.com | info@elationlighting.com

Elation Professional B.V. | Junostraat 2 | 6468 EW Kerkrade, The Netherlands

+31 45 546 85 66 | www.elationlighting.eu | info@elationlighting.eu

Elation Professional Mexico | AV Santa Ana 30 | Parque Industrial Lerma, Lerma, Mexico 52000

+52 (728) 282-7070

DOCUMENT VERSION



Due to additional product features and/or enhancements, an updated version of this document may be available online. Please scan the QR Code with your mobile device or visit www.elationlighting.com for the latest revision/update of this manual, before installation and/or programming.

Date	Document Version	SoftwareVersion ≥	DMX Channel Modes	Notes
04/02/2025	1.0	1.0.0	42/58	Initial Release
07/03/2025	1.1	N/A	N/A	Update Specifications
11/04/2025	1.2	N/A	N/A	Update Power Specification
12/11/2025	1.3	N/A	N/A	Updated: General Info, Installation Guidelines, Specifications
04/13/2026	1.4	N/A	N/A	Updated Specifications

CONTENTS

General Information	4
IP65 Rated	5
Safety Guidelines	6
Overview	8
Colors and Gobos	9
Custom Gobos	10
Gobo Installation	11
Custom Logo Plate Installation	13
Torque Settings for Screws	14
IP Test Parameters	15
Installation Guidelines	16
Frequency & Wireless Location Guidelines	21
System Menu	22
Sun Protection Mode Hibernation Mode	24
Fan Modes and Low Noise Operation	25
Dimmer Modes and Dimmer Curves	26
DMX Traits	27
Remote Device Management (RDM)	36
Maintenance Guidelines	37
Error Codes	38
Software Updates	39
Specifications	40
Dimensional Drawings	41
Optional Accessories FCC Statement	42

GENERAL INFORMATION

INTRODUCTION

Please read and understand the instructions in this manual carefully and thoroughly before attempting to operate this device. These instructions contain important safety and use information. **This device is intended for professional use only.**

UNPACKING

Every device has been thoroughly tested and has been shipped in perfect operating condition. Carefully check the shipping carton for damage that may have occurred during shipping. If the carton is damaged, carefully inspect the device for damage, and be sure all accessories necessary to install and operate the device have arrived intact. In the event damage has been found or parts are missing, please contact our customer support team for further instructions. Please do not return this device to your dealer without first contacting customer support. Please do not discard the shipping carton in the trash. Please recycle whenever possible.

BOX CONTENTS

(x1) IP65 Rated Power Cable
(x2) Omega Brackets
(x1) Safety Cables

CUSTOMER SUPPORT

Contact ELATION Service for any product related service and support needs. Also visit forums.elationlighting.com with questions, comments or suggestions.

ELATION SERVICE USA - Monday - Friday 8:00am to 4:30pm PST
323-582-3322 | support@elationlighting.com

ELATION SERVICE EUROPE - Monday - Friday 08:30 to 17:00 CET
+31 45 546 85 63 | support@elationlighting.eu

REPLACEMENT PARTS please visit parts.elationlighting.com

LIMITED WARRANTY

For up-to-date warranty information regarding your device, please visit Elation's warranty information page online or scan the QR codes below.



USA: <https://www.elationlighting.com/warranty-information>



EU: https://www.elationlighting.eu/terms_and_conditions

THERE ARE NO USER SERVICEABLE PARTS INSIDE THIS UNIT. DO NOT ATTEMPT ANY REPAIRS YOURSELF, AS DOING SO WILL VOID YOUR MANUFACTURER'S WARRANTY. DAMAGES RESULTING FROM MODIFICATIONS TO THIS FIXTURE AND/OR THE DISREGARD OF SAFETY INSTRUCTIONS AND GUIDELINES IN THIS MANUAL VOID THE MANUFACTURER'S WARRANTY AND ARE NOT SUBJECT TO ANY WARRANTY CLAIMS AND/OR REPAIRS.

IP65 RATED

The **International Protection (IP)** rating system is commonly expressed as “**IP**” (Ingress Protection) followed by two numbers (i.e. IP65), where the numbers define the degree of protection. The first digit (Foreign Bodies Protection) indicates the extent of protection against particles entering the fixture, and the second digit (Water Protection) indicates the extent of protection against water entering the fixture. An **IP65** rated lighting fixture is designed and tested to protect against the ingress of dust (**6**), and low-pressure water jets from any direction (**5**).

NOTE: THIS FIXTURE IS INTENDED FOR TEMPORARY OUTDOOR USE ONLY!

Maritime/Seaside Environment Installations: A maritime/seaside environment is adjacent to the sea and caustic to electronics through exposure to atomized salt water and humidity, whereas a coastal environment extends 5 miles inland.



NOT suitable for maritime/seaside environment installations. Installing this fixture in a maritime/seaside environment may cause corrosion and/or excessive wear to the interior and/or exterior components of the fixture. Damages and/or performance issues resulting from installation in a maritime/seaside environment will void the manufacturer’s warranty, and will NOT be subject to any warranty claims and/or repairs.

Maritime installations require additional preparation, and additional service intervals may be needed given the maritime use. In general, IP ratings presuppose freshwater conditions VS maritime conditions, which are typically more “caustic” to IP fixtures (both internally and externally). A duty-cycle may also be needed when units are not in use. During times of high humidity and colder temperatures, condensation may occur internally so the fixture may require a duty-cycle to bring it up to running temperature, allowing any accumulation of moisture to be expelled via the vent valve. Recommendations can change based on installation environmental circumstances. A waterproof dome or similar device is recommended for use in permanent outdoor installations. When using a dome, refer to manufacturer recommendations for duty-cycle.

NOTE: NOT ALL FEATURES LISTED ARE AVAILABLE ON ALL FIXTURES; THE FOLLOWING INSTRUCTIONS MAY NOT APPLY. CONTACT SUPPORT FOR ADDITIONAL DETAILS.

Exterior Maintenance: Inspect the exterior every 30-days. The unit must be powered off/disconnected. The chassis should be inspected for any signs of contaminants. Inspect optics to determine if the lens is obstructed, then clean optics and chassis accordingly. Based on initial finding, schedule maintenance accordingly, keeping in mind that exterior maintenance will be required. Even if the luminaires are NOT in use, maintenance will still be needed given its location (exterior use). The use of a durable type of wax on the chassis is recommended since it will help prevent contaminant build up. Inspect both power and data lines for any signs of contaminants or corrosion. Periodically reapplying di-electric grease, especially in coastal environments. If any signs of corrosion/contaminants are present, clean thoroughly, and/or replace connectors, then reapply di-electric grease. Typically, this should be done annually, or any time an opportunity presents itself. As a preventive measure, annual replacement of both vent valves is recommended. The vent valve membrane can become contaminated and/or clogged causing improper venting of humidity within the luminaire. Inspect all mounting hardware as a precaution.

Interior Maintenance: Inspect the interior every 30-days. The unit must be powered off/disconnected.

- Inspect zoom/focus mechanism, clean optics, lubricate linear bearings (Krytox oil) as needed, inspect belts for wear
- Inspect all rotating effect wheels, manually rotate them, note any resistance
- Inspect all remaining rotating belts for any wear
- Inspect all fans, clean as needed, check rotation, check connections
- Inspect CMY module, manually move flags and check for signs of resistance, and if needed, clean guide rods first, then reapply a thin layer of grease (moly lube)
- Clean interior with low-volume compressed air, then clean optics prior to reassembly of head covers

Although the base has limited moving parts, the pan belt should also be inspected for wear. Remember to always perform an IP test anytime a cover is removed.

There is no specific time frame regarding the routine replacement of parts such as belts/stepper motors, PCBs, or LEDs. These items should only be replaced on an as needed bases, except for cooling fans, which should be replaced once the luminaries reach 10,000-hours. This is a prophylactic measure intended to keep the unit running as cool as possible, insuring proper function of all internal components. A complete service breakdown is available, please contact service@elationlighting.com for any needed parts or manuals.

SAFETY GUIDELINES

This fixture is a sophisticated piece of electronic equipment. To guarantee a smooth operation, it is important to follow all instructions and guidelines in this manual. Elation Professional is not responsible for injury and/or damages resulting from the misuse of this fixture due to the disregard of the information printed in this manual. Only qualified and/or certified personnel should perform installation of this fixture and only the original rigging parts (omega brackets) included with this fixture should be used for installation. Any modifications to the fixture and/or the included mounting hardware will void the original manufacturer's warranty and increase the risk of damage and/or personal injury.



PROTECTION CLASS 1 - FIXTURE MUST BE PROPERLY GROUNDED.



THERE ARE NO USER SERVICEABLE PARTS INSIDE THIS UNIT. DO NOT ATTEMPT ANY REPAIRS YOURSELF; DOING SO WILL VOID YOUR MANUFACTURER'S WARRANTY. DAMAGES RESULTING FROM MODIFICATIONS TO THIS FIXTURE AND/OR THE DISREGARD OF SAFETY INSTRUCTIONS AND GUIDELINES IN THIS MANUAL VOID THE MANUFACTURE'S WARRANTY AND ARE NOT SUBJECT TO ANY WARRANTY CLAIMS AND/OR REPAIRS.



**DO NOT PLUG FIXTURE INTO A DIMMER PACK!
NEVER OPEN THIS FIXTURE WHILE IN USE!
UNPLUG POWER BEFORE SERVICING FIXTURE!
NEVER TOUCH FIXTURE DURING OPERATION, AS IT MAY BE HOT!
KEEP FLAMMABLE MATERIALS AWAY FROM FIXTURE!**

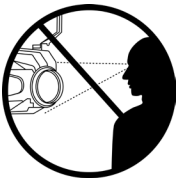

**NEVER LOOK DIRECTLY INTO THE LIGHT SOURCE!
RETINA INJURY RISK - MAY INDUCE BLINDNESS!
SENSITIVE PERSONS MAY SUFFER AN EPILEPTIC SHOCK!**



**MINIMUM DISTANCE TO OBJECTS/SURFACES MUST BE 10 FEET (3 METERS)
MAXIMUM TEMP OF EXTERNAL SURFACE 176°F (80°C)
MINIMUM DISTANCE OF INFLAMMABLE MATERIALS 1.6 FEET (0.5 METER)**

1. The light source in this luminaire should only be replaced by the manufacturer, their authorized service agent, or a similarly qualified individual.
2. Position the luminaire so that prolonged staring into it from a distance closer than 3.8 meters is unlikely.
3. Replace shields, lenses, or ultraviolet screens if they are visibly damaged—such as by cracks or deep scratches—to the extent that their effectiveness is compromised.
4. Replace the lamp if it becomes damaged or thermally deformed.
5. This luminaire is designed exclusively for professional use.

SAFETY GUIDELINES

 <p>66 lbs. (30 kg)</p>	<p>WARNING</p> <p>TWO PERSON LIFT REQUIRED</p>
----------------------------------------------------------------------------------------------------------	------------------------------------------------------------------

DO NOT TOUCH the fixture housing during operation. Turn **OFF** the power and allow approximately 15 minutes for the fixture to cool down before serving.

DO NOT shake fixture, avoid brute force when installing and/or operating fixture.

DO NOT operate fixture if the power cord is frayed, crimped, damaged and/or if any of the power cord connectors are damaged and do not insert into the fixture securely with ease. **NEVER** force a power cord connector into the fixture. If the power cord or any of its connectors are damaged, replace it immediately with a new one of similar power rating.

DO NOT block any air ventilation slots.

All fan and air inlets must remain clean and never blocked.

Allow approx. 3.3' (1m) between fixture and other devices or a wall for proper cooling.

Always disconnect fixture from main power source before performing any type of service and/or cleaning procedure. Only handle the power cord by the plug end, never pull out the plug by tugging the wire portion of the cord.

During the initial operation of this fixture, a light smoke or smell may emit from the interior of the fixture. This is a normal process and is caused by excess paint in the interior of the casing burning off from the heat associated with the lamp and will decrease gradually over time.

Consistent operational breaks will ensure fixture will function properly for many years.

ONLY use the original packaging and materials to transport the fixture in for service.

OVERVIEW

NFC Access Point

LCD Display

Battery Indicator

Up Button

Enter Button

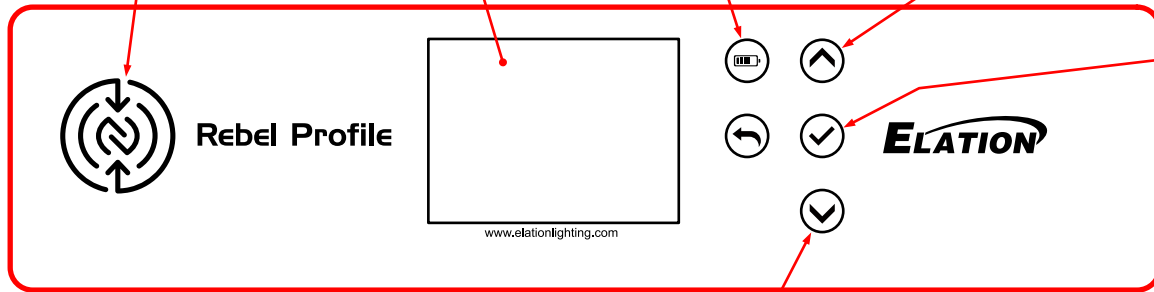

Down Button

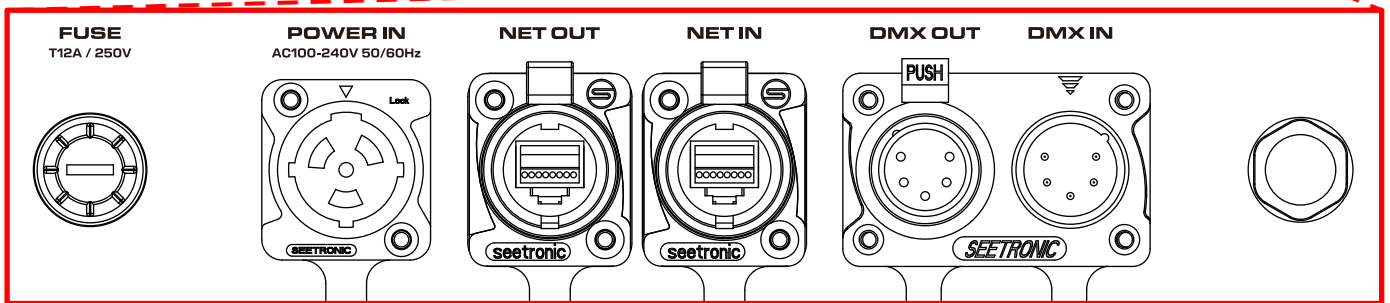
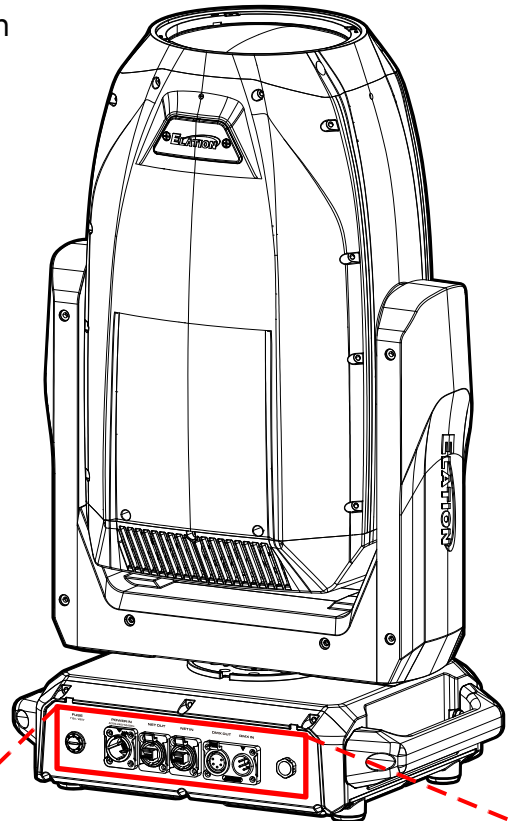
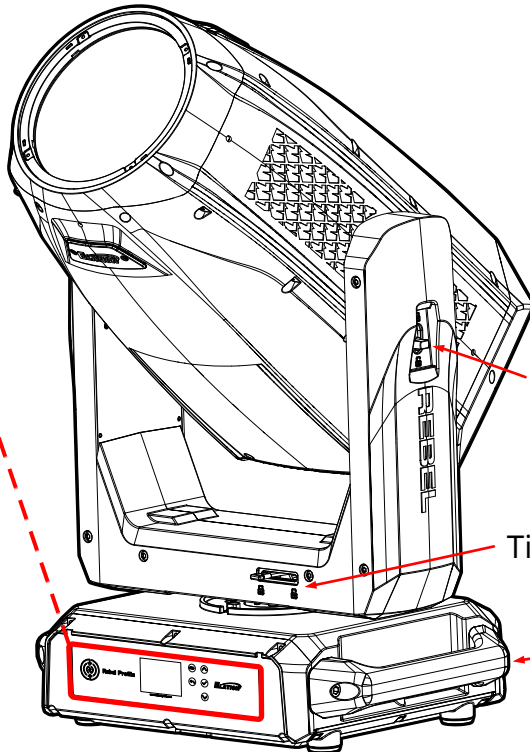

Fuse

Power In/Out

Net Out/In

DMX Out /In

Valve

Safety Cable Anchor Point

Omega Bracket Installation Point

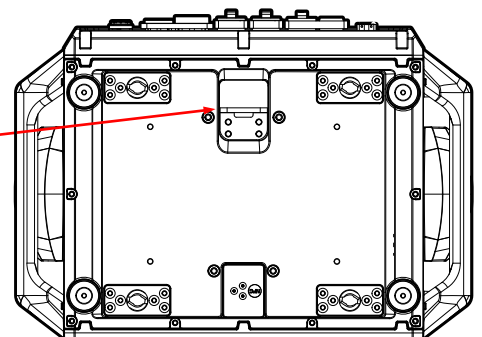

COLORS AND GOBOS

ROTATING GOBO WHEEL

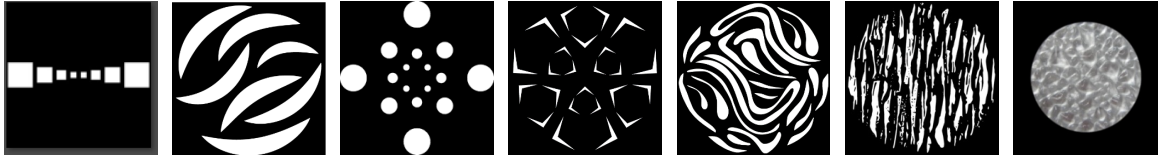

POS 1

POS 2

POS 3

POS 4

POS 5

POS 6

POS 7

FIXED GOBO WHEEL

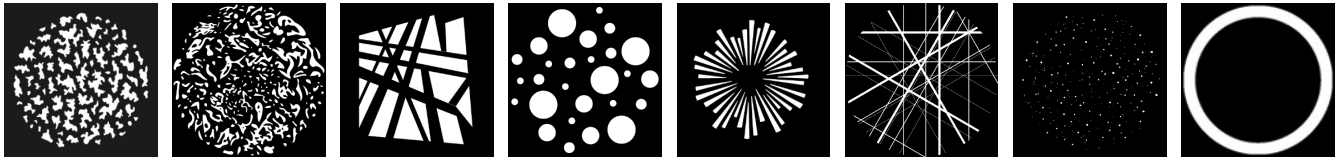

POS 1

POS 2

POS 3

POS 4

POS 5

POS 6

POS 7

POS 8

ANIMATION WHEEL

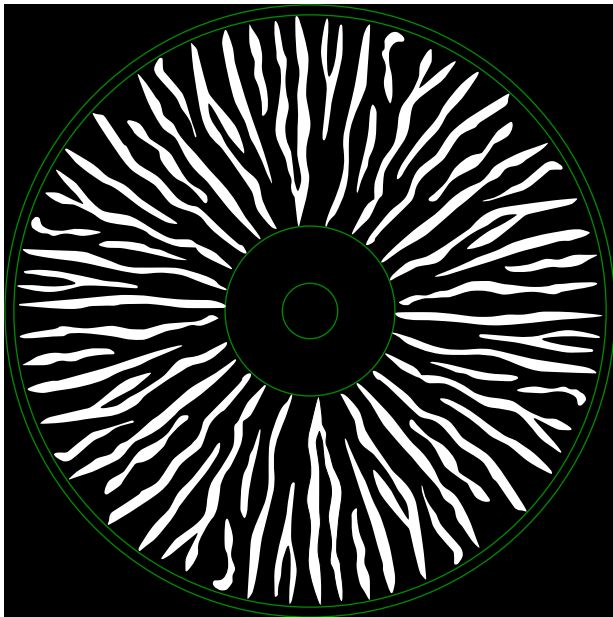

COLOR WHEEL

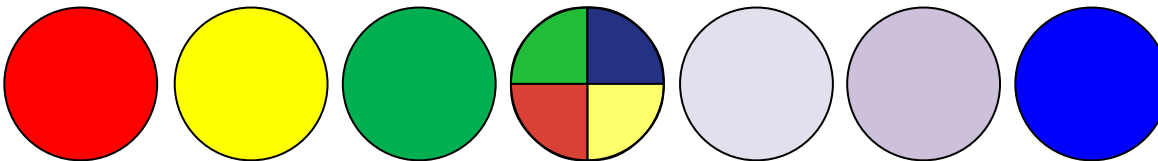

POS 1
RED

POS 2
YELLOW

POS 3
GREEN

POS 4
QUAD
COLOR

POS 5
HIGH
CRI 80

POS 6
HIGH CRI
90

POS 7
BLUE

PRISM

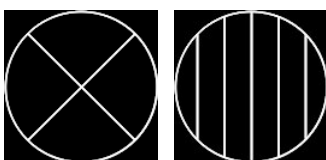

POS 1
4 FACET

POS 2
6 FACET
LINEAR

CUSTOM GOBOS

ROTATING GOBO WHEEL GOBO & HOLDER

ROTATING GOBO WHEEL GOBOS	
Gobo O.D. (Max. Outer Diameter)	ø23mm
Gobo O.D. (Max. Outer Diameter)	ø15mm
Gobo Thickness	1.1mm
Gobo Material	GLASS

Gobo

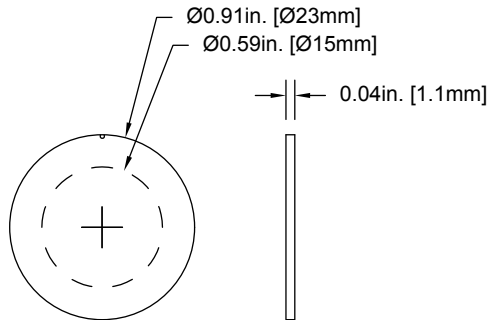

Gobo Holder

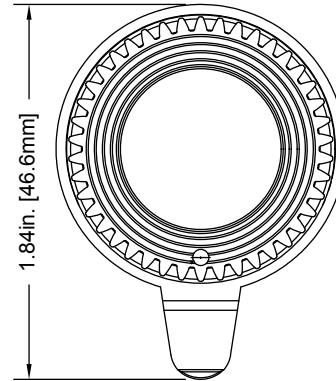

FIXED GOBO WHEEL GOBO

FIXED GOBO WHEEL GOBOS	
Gobo O.D. (Max. Outer Diameter)	ø23mm
Gobo O.D. (Max. Outer Diameter)	ø11mm
Gobo Thickness	1.1mm
Gobo Material	GLASS

Gobo

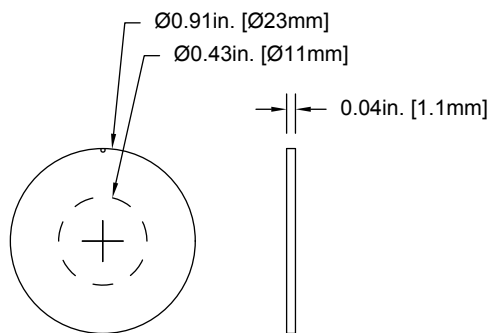

Please be aware of the intended position and correct sizing requirements of custom gobos.

***** IMPORTANT NOTICE REGARDING CUSTOM GOBOS *****

Due to the high temperature optical system, special material is required for custom gobos. Due to varying manufacturing processes and tolerances, it is highly recommended to provide a gobo sample and holder from the fixture to the custom gobo vendor for accurate sizing. Extended testing of custom gobo designs is highly recommended prior to use. Contact ELATION SERVICE for further information.

ELATION SERVICE USA -Monday -Friday 8:00am to 4:30pm PST
323-582-3322 | support@elationlighting.com

ELATION SERVICE EUROPE -Monday -Friday 08:30 to 17:00 CET
+31 45 546 85 63 | support@elationlighting.eu

GOBO INSTALLATION

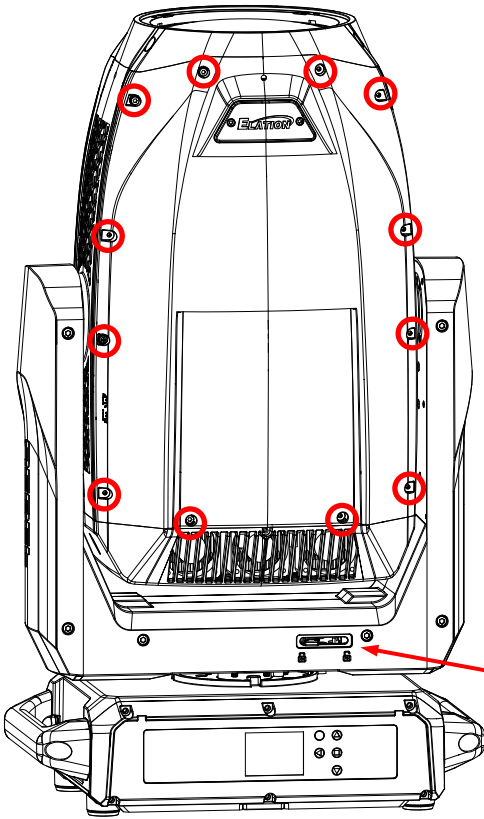

Place the fixture on a firm flat surface. Locate the (12x) hex screws securing the panel on the **Pan Lock** side of the moving head and remove them.

Pan Lock

Locate the Rotating Gobo Wheel Assembly Module, remove the screws that secure it to the internal housing frame, and unplug/disconnect wire harness.

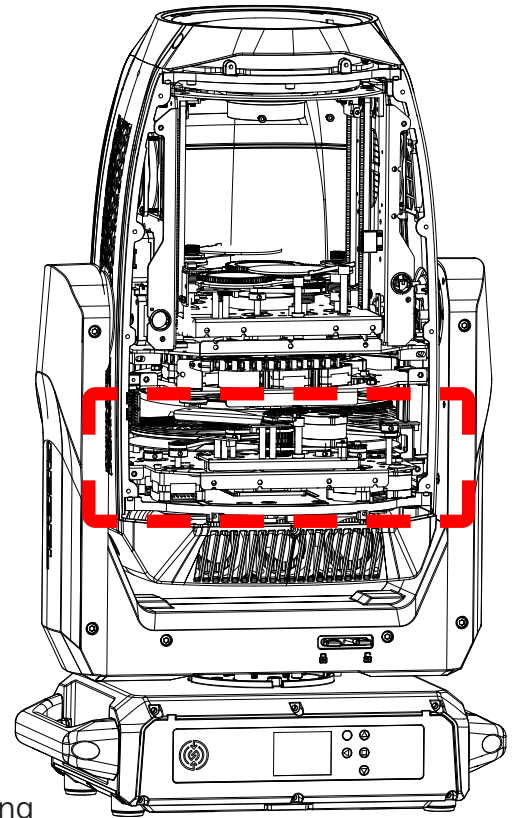

Carefully remove the Rotating Wheel Gobo Assembly Module and set it on a clean surface.

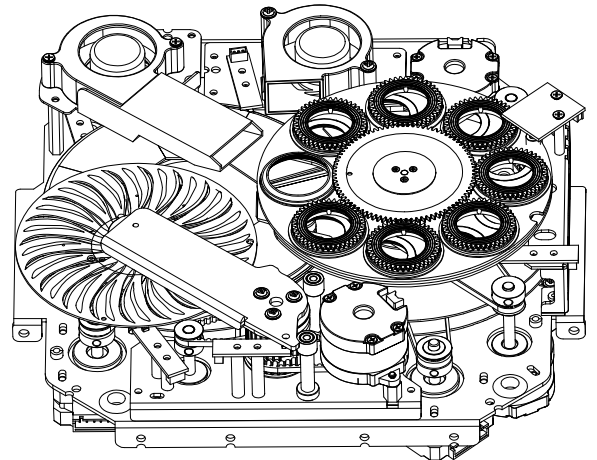
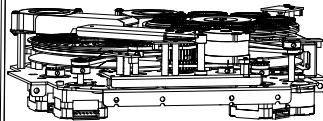
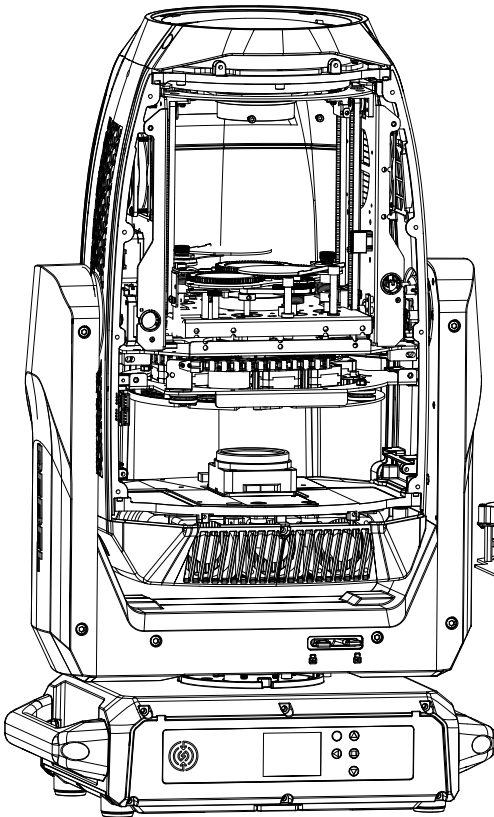

GOBO INSTALLATION

Locate the specific Rotating Gobo to replace. Carefully grip the Gobo using your thumb and index finger, gently lift it slightly, and then pull it out and away until it fully clears the Gobo Wheel.

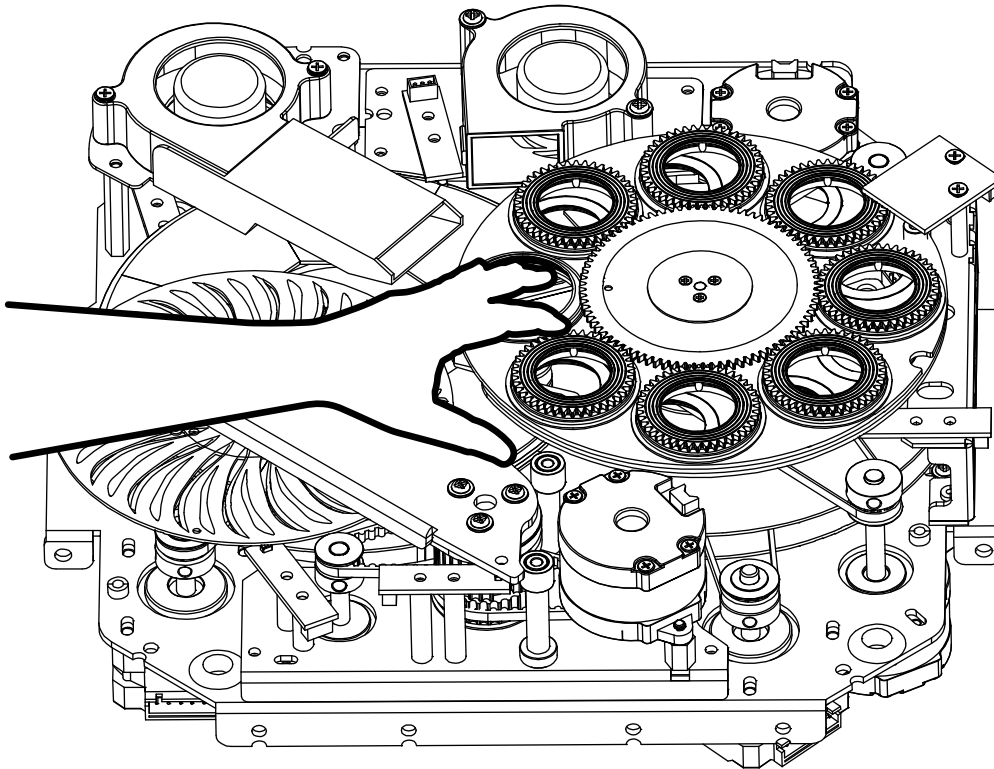

CAUTION: TAKE CARE NOT TO SCRATCH GOBO OR GOBO HOLDER

Locate the tab of the Retention Spring, and with a precision pick (or similar tool), carefully press the Retaining Spring inward to relieve the tension. Remove the retaining spring and carefully separate the GOBO from the GOBO Holder.

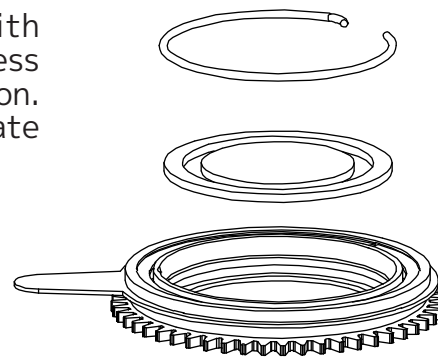
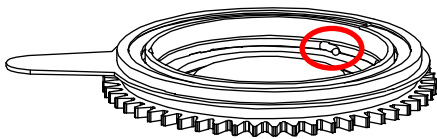

Note: To ensure proper Gobo orientation on the Rotating Gobo Wheel, align the Alignment Indices before installing the Retention Spring.

CUSTOM LOGO PLATE INSTALLATION

To install a Logo Plate, ensure the fixture is powered off and disconnected.

Locate and remove the existing Elation Logo Plate using a hex driver by unscrewing the two holding screws. Using the existing mounting screws, align the screw holes of the new badge with the mounting holes of the fixture.

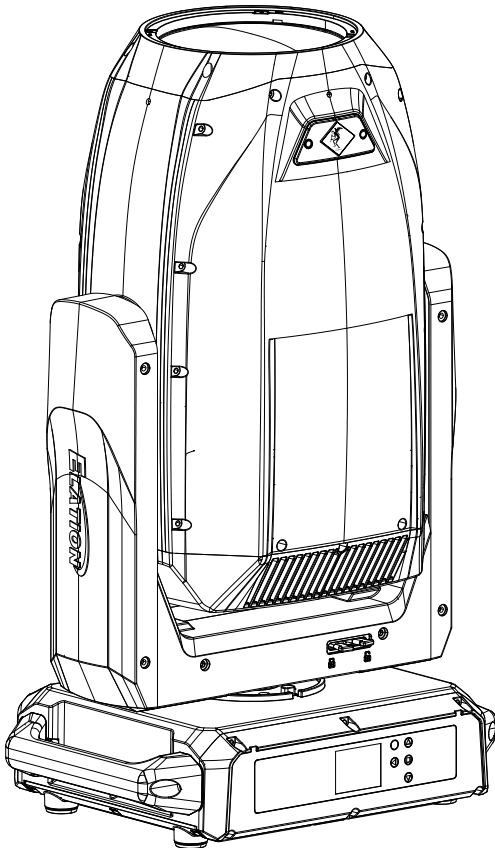
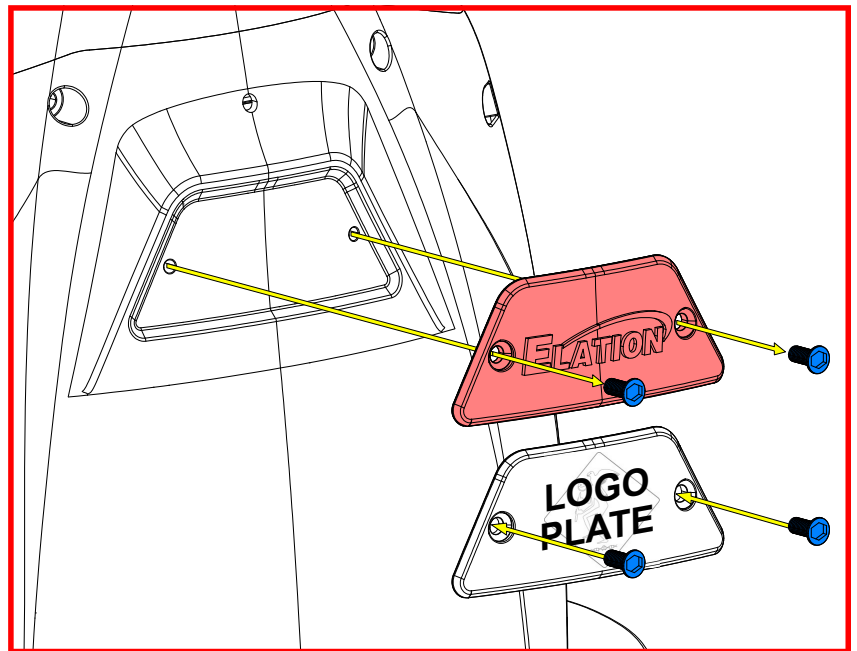
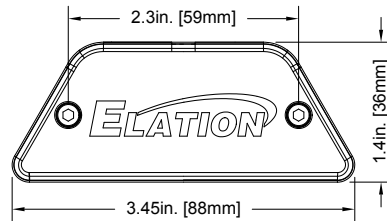
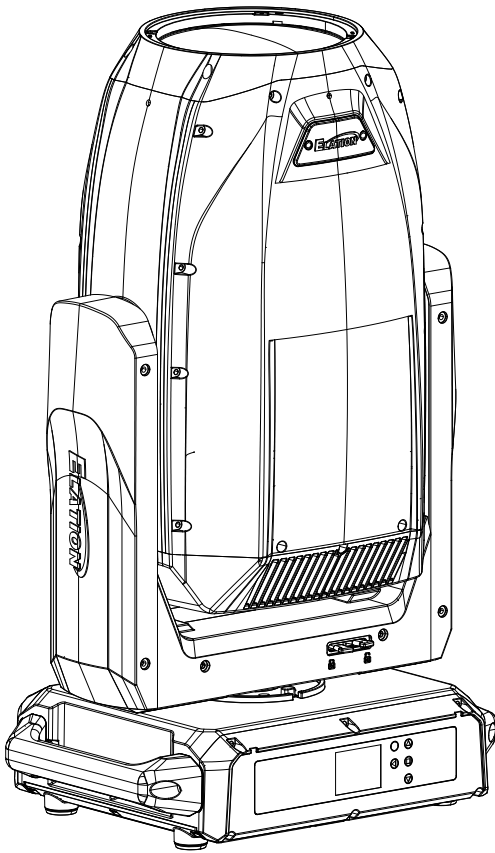

Gently screw the new Logo Plate into place, making sure it is flush and straight. Do not overtighten to prevent damage to the badge or the fixture.

After installation, check that the Logo Plate does not interfere with any moving parts of the fixture. Once everything looks good, reconnect the power, turn on the fixture, and observe its operation to ensure the badge installation has not affected functionality. Periodically check the badge for tightness, particularly after transportation or if the fixture is frequently moved, to avoid it becoming loose over time.

TORQUE SETTINGS FOR SCREWS



PANEL SCREWS MUST BE TIGHTENED WITH A TORQUE WRENCH ACCORDING TO THE TORQUE SPECIFICATION DESCRIBED BELOW.



CAUTION! DO NOT OVER TORQUE SCREWS AS THIS CAN CAUSE LEAKAGE ISSUES! TO CONFIRM THE IP65 INTEGRITY AFTER A PROCEDURE REQUIRING DISASSEMBLY/REASSEMBLY, TEST THE FIXTURE USING THE IP TESTER. CONTACT ELATION SERVICE FOR MORE DETAILS.



CAUTION! THE USE OF PROTECTIVE GLOVES AND SAFETY GOGGLES IS STRONGLY RECOMMENDED WHILE PERFORMING THE IP PRESSURE TEST! AVOID PLACING YOUR FACE, EYES, HANDS, ETC IN CLOSE PROXIMITY TO THE FIXTURE'S LENS WHILE PERFORMING THE TEST!

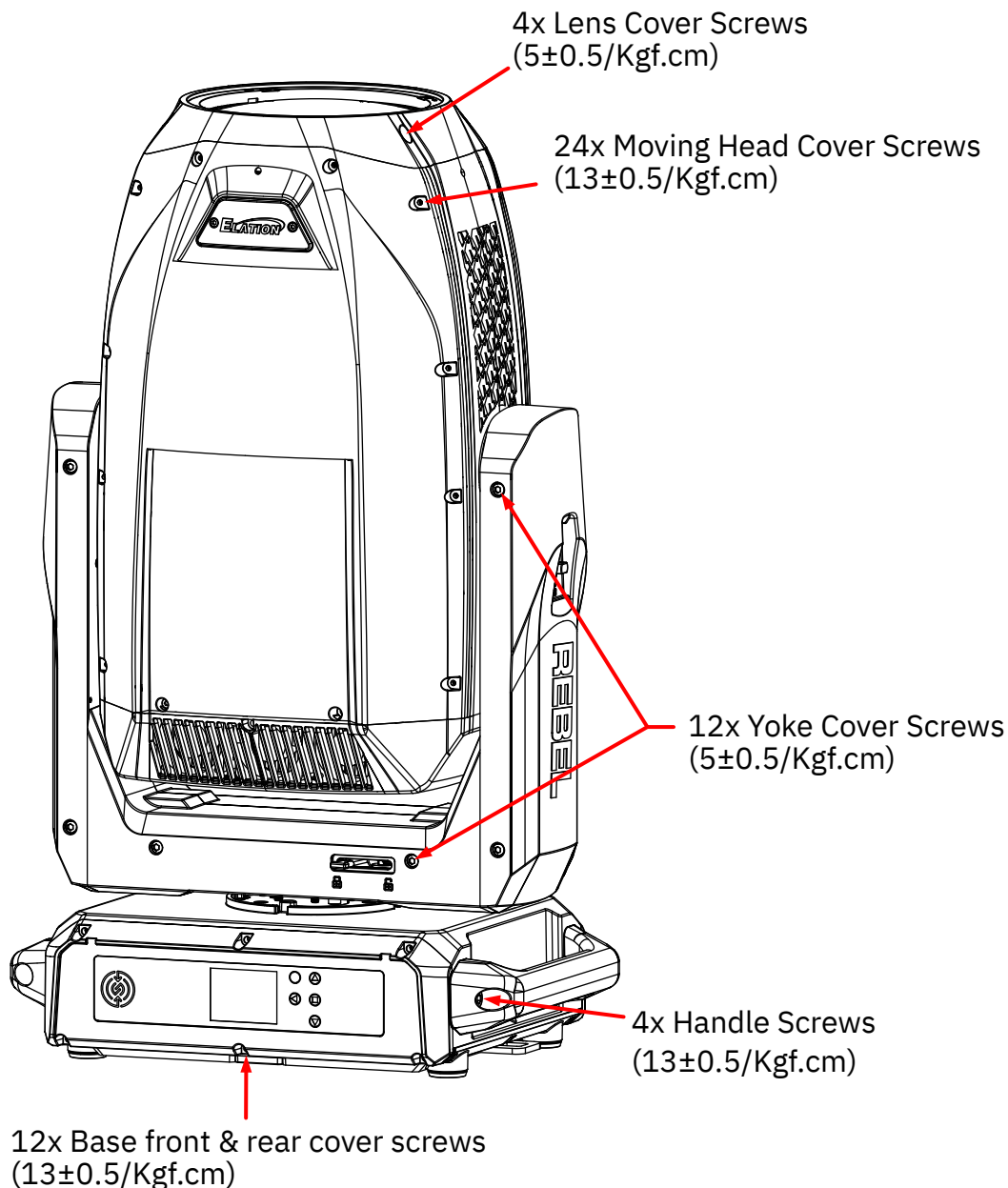

IP TEST PARAMETERS

Following any repair or maintenance procedure that requires disassembly of the fixture, use Elation's IP Tester to confirm the IP integrity of the fixture. Please contact Elation Service for information regarding the Elation IP Tester, or visit the product information page online at: <https://www.elationlighting.com/ip-tester>



CAUTION! THE USE OF PROTECTIVE GLOVES AND SAFETY GOGGLES IS STRONGLY RECOMMENDED WHILE PERFORMING THE IP PRESSURE TEST! AVOID PLACING YOUR FACE, EYES, HANDS, ETC IN PROXIMITY TO THE LENS OF THE FIXTURE WHILE PERFORMING THE TEST!

DE-HUMIDIFICATION: IP65 fixtures operating in high-humidity environments may experience residual fogging or condensation. Such fogging will not affect the fixture, and can be removed using the following procedure: position the unit with the air valve pointing upwards, then open the air valve and run the unit for 1-2 hours after reaching operating temperature. Then, while the fixture is still hot, re-install the air valve and allow the unit to cool down. Please note: this procedure should be performed in a dry, climate-controlled environment. Avoid additional fogging by drying the fixture completely before placing into a road case.

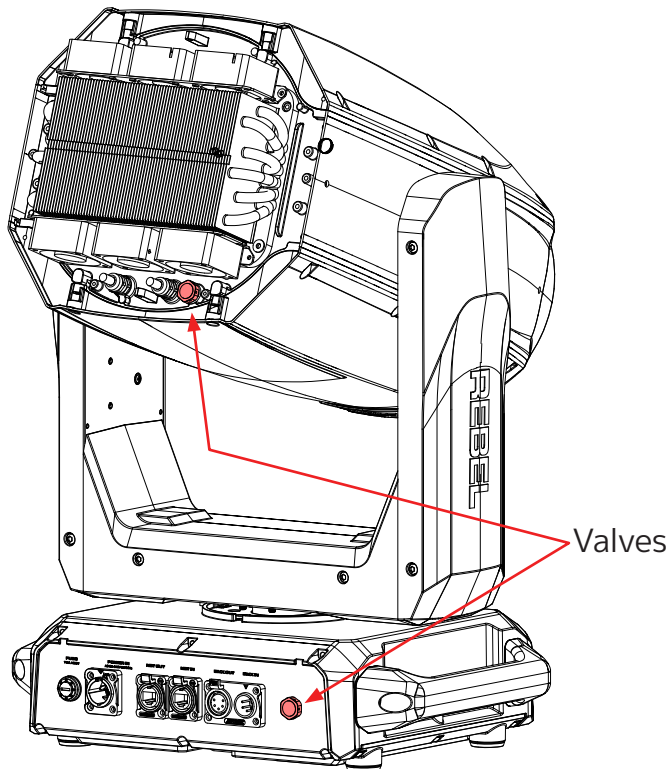

IP PRESSURE TESTING PARAMETERS			
Test Type	Low Pressure Limit	High Pressure Limit	Hold Time
Vacuum Test	-4.35psi (-30.00 KPa)	-5.08 psi (-35.00 KPa)	10s
Pressure Test	3.62 psi (25.00 KPa)	4.35 psi (30.00 KPa)	10s

FIXTURE DISASSEMBLY

The following points should be observed after performing any maintenance procedure that requires disassembly of the unit:

- After the unit has been reassembled, open the valve and allow the unit to run for approximately 2 hours in order to dry out any moisture that has been trapped inside the fixture. The process should continue until indicated humidity drops below 15% for the head and 30% for the base.
- Once this has been achieved, the light can be switched off, but the unit should remain connected to power so that the cooling fan can cool down the unit. Please note that allowing cool down time should **ALWAYS** be done after lamp operation.
- Some units may require partial disassembly in order to gain access to the valve. Please contact Elation service for information regarding the location and access procedure for the valve on your specific unit model.

INSTALLATION GUIDELINES



FLAMMABLE MATERIAL WARNING

Keep fixture minimum 5.0 feet (1.5m) away from flammable materials and/or pyrotechnics.



ELECTRICAL CONNECTIONS

A qualified electrician should be used for all electrical connections and/or installations.



USE CAUTION WHEN POWER LINKING OTHER MODEL FIXTURES AS THE POWER CONSUMPTION OF OTHER MODEL FIXTURES MAY EXCEED THE MAX POWER OUTPUT ON THIS FIXTURE. CHECK SILK SCREEN FOR MAX AMPS.



**MINIMUM DISTANCE TO OBJECTS/SURFACES
MUST BE 1.6 FOOT (0.5 METERS)**



**MINIMUM DISTANCE OF INFLAMMABLE MATERIALS
FROM THE SURFACE 1.6 FEET (0.5 METER)**



MAXIMUM AMBIENT TEMPERATURE 194° F (90°C)



DO NOT INSTALL THE FIXTURE IF YOU ARE NOT QUALIFIED TO DO SO!

Fixture **MUST** be installed following all local, national, and country commercial electrical and construction codes and regulations.

Before rigging/mounting the fixture to any metal truss/structure or placing the fixture on any surface, a professional equipment installer **MUST** be consulted to determine if the metal truss/structure or surface is properly certified to safely hold the combined weight of the fixture, clamps, cables, and accessories.

Overhead rigging requires extensive experience, including, amongst others, calculating working load limits, installation material being used, and periodic safety inspection of all installation material and the fixture. If you lack these qualifications, do not attempt the installation yourself. Improper installation can result in bodily injury.

Fixture ambient operating temperature range is **-4° to 113°F. (-20° to 45°C)**

Do not use the fixture under or above this temperature.

Fixture should be installed in areas outside walking paths, seating areas, or away from areas where unauthorized personnel might reach the fixture by hand.

NEVER stand directly below the fixture when rigging, removing or servicing.

Overhead fixture installation must always be secured with a secondary safety attachment, such as an appropriately rated safety cable.

Allow approximately 10 minutes for the fixture to cool down before servicing.

INSTALLATION GUIDELINES

OMEGA BRACKETS WITH CLAMP INSTALLATION

When mounting the fixture to a truss, be sure to secure an appropriately rated professional grade rigging clamp to the included **Omega Brackets** using an M10 screw fitted through the center hole of the **Omega Brackets**. Insert the Omega Brackets into the matching holes on the bottom of the fixture. Secure the Omega Brackets to the fixture by turning each quick-lock fastener ¼ turn clockwise; making sure the fastener is completely locked. Omega Brackets can be installed into the fixture base as illustrated below.

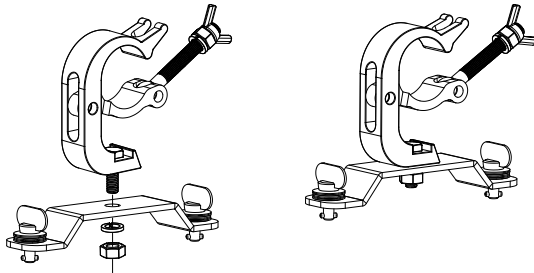

SAFETY CABLE
ALWAYS ATTACH AN APPROPRIATELY RATED SAFETY CABLE WHENEVER INSTALLING THIS FIXTURE IN A SUSPENDED ENVIRONMENT TO ENSURE THE FIXTURE WILL NOT FALL IF THE CLAMP FAILS.

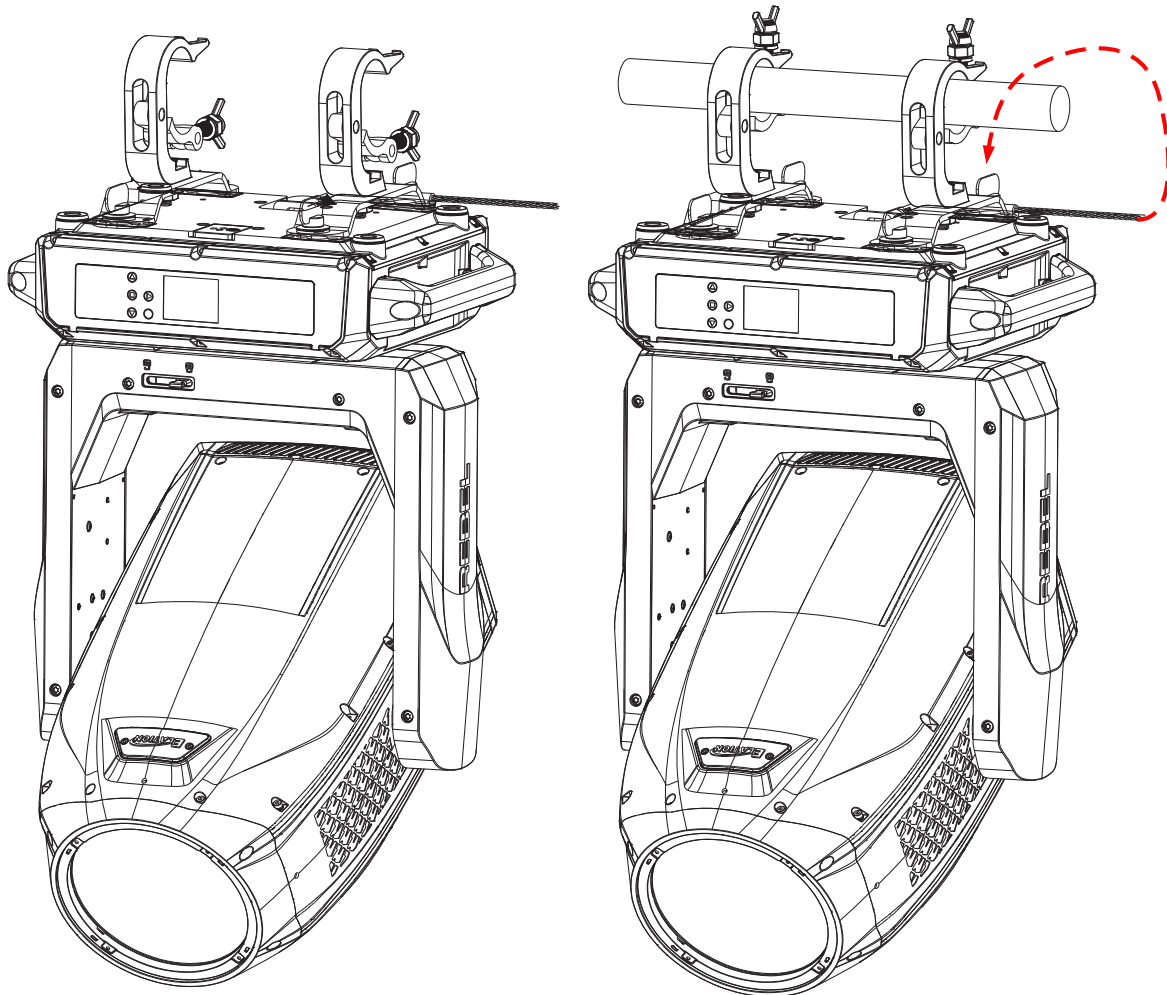

RIGGING

Overhead rigging requires extensive experience, including among others, calculating working load limits, installation material being used, and periodic safety inspection of all installation material and the fixture. If you lack these qualifications, do not attempt the installation yourself. Improper installation can result in bodily injury. The fixture provides a built-in rigging point for a **SAFETY CABLE** (not included). Be sure to only use one of the designated rigging point for the safety cable and never secure a safety cable to a carrying handle. Connect the safety cable to the attachment point and route it around the truss.

INSTALLATION GUIDELINES

FIXTURE INSTALLATION

The Elation Rebel Profile is fully operational in three different mounting positions, hanging upside-down, mounted sideways on trussing, or set on a flat level surface. Be sure this fixture is kept at least (1.6' (0.5m)) away from any flammable materials (decoration etc.). Always use and install the supplied safety cable as a safety measure to prevent accidental damage and/or injury in the event the clamp fails. Never use the carrying handles for secondary attachment.

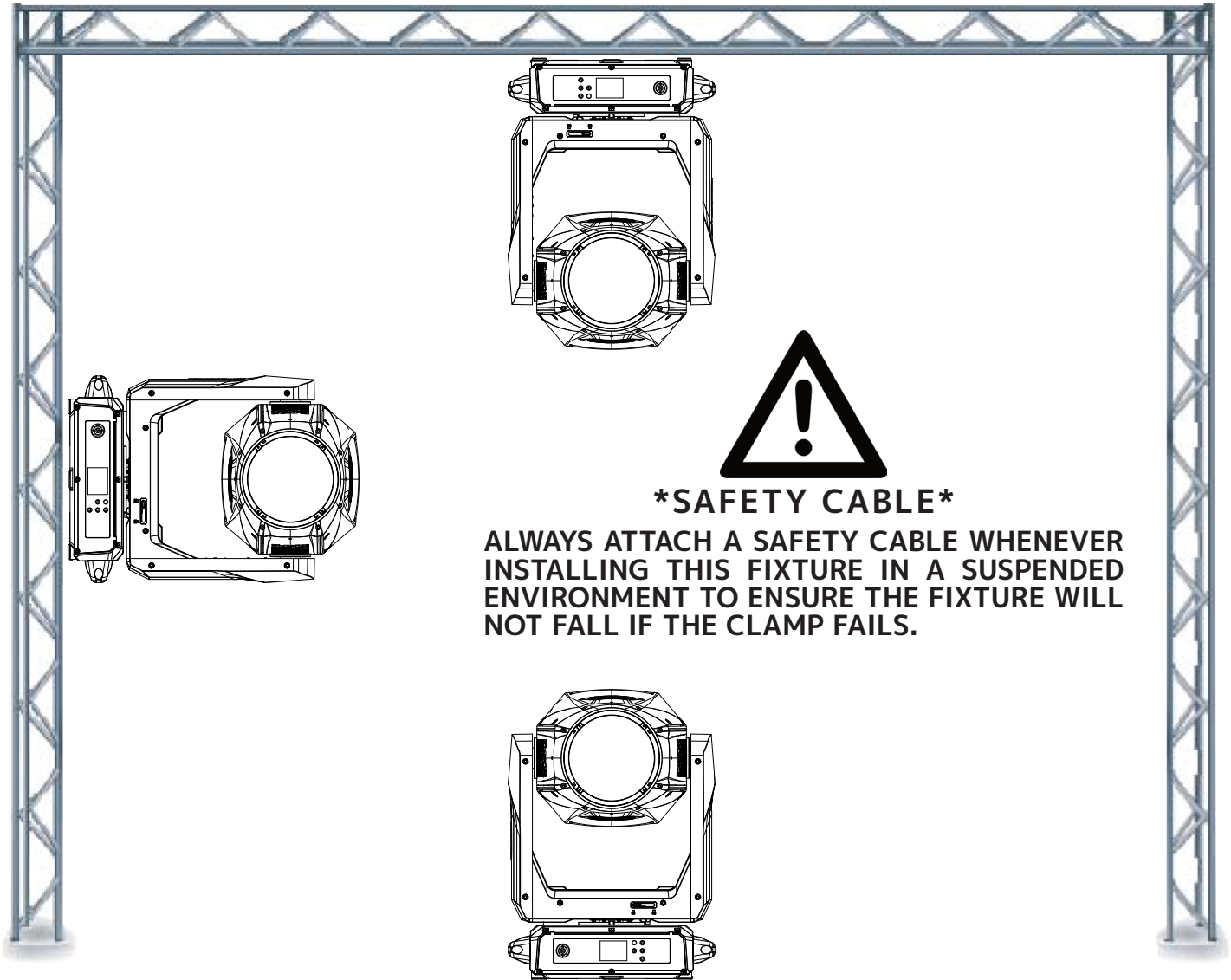

INSTALLATION GUIDELINES

POWER AND DATA CABLES



ENSURE ALL CONNECTIONS AND END-CAPS ARE PROPERLY SEALED WITH DIELECTRIC GREASE (AVAILABLE AT MOST ELECTRICAL SUPPLIERS) TO PREVENT WATER CORROSION AND/OR ELECTRICAL SHORT CIRCUIT.



TO MAINTAIN THE IP65 RATING INTEGRITY OF THE FIXTURE, ALL CABLES MUST BE RUN TOWARDS THE GROUND TO PREVENT WATER ACCUMULATION AROUND THE CONNECTIONS.

SYSTEM MENU LCD DISPLAY

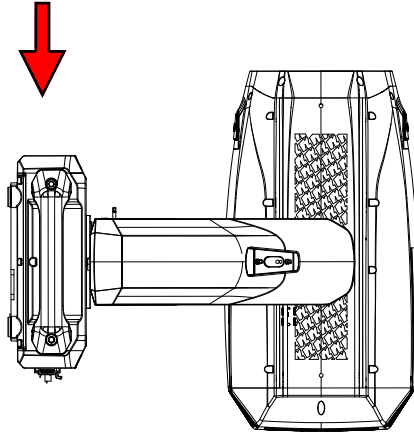

CABLES

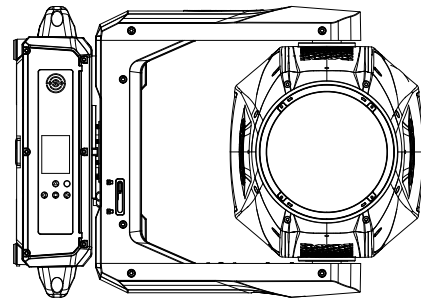

CABLES

INSTALLATION GUIDELINES

POTENTIAL INTERNAL FIXTURE DAMAGE FROM EXTERNAL SOURCES OF LIGHT BEAMS

External sources of light beams from direct sunlight, lighting moving head fixtures, and lasers, which are focused directly towards the exterior housing and/or penetrate the front lens opening of ELATION lighting fixtures, can cause severe internal damage including burning to optics, dichroic color filters, glass and metal gobos, prisms, animation wheels, frost filters, iris, shutters, motors, belts, wiring, discharge lamps, and LEDs.

This issue is not specific only to ELATION lighting fixtures, it is a common issue with lighting fixtures from all manufacturers. Although there is no true way to fully prevent this issue from happening, the guidelines below can prevent any potential damage from occurring if followed. Contact ELATION Service for more details.

DO NOT EXPOSE THE FIXTURE AND/OR FRONT LENS OPENING TO LIGHT BEAMS FROM DIRECT SUNLIGHT, OTHER LIGHTING MOVING HEAD FIXTURES, AND LASERS WHILE UNPACKING, INSTALLATION, USE, AND EXTENDED IDLE TIMES OUTDOORS. DO NOT FOCUS A LIGHT BEAM FROM ONE LIGHTING FIXTURE DIRECTLY TOWARDS ANOTHER.

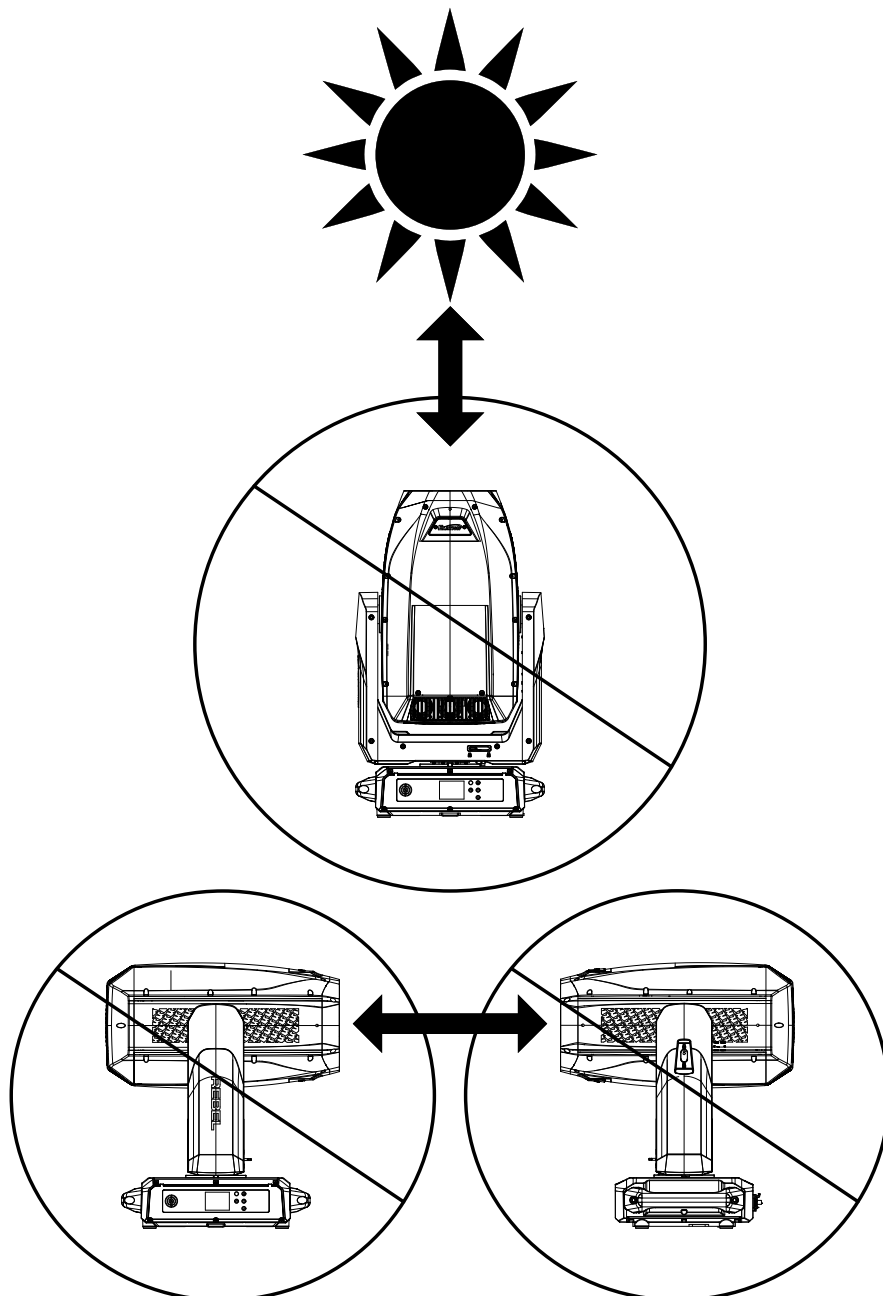

FREQUENCY & WIRELESS LOCATION GUIDELINES

2GHZ Versus Sub-Gig (GHz) Frequencies:

Sub-GHz frequencies provide superior reliability and range compared to higher frequencies, making them perfect for consistent communication across vast distances or in difficult conditions. Devices operating in the sub-GHz range, which refers to frequencies below 1 GHz, can transmit signals over significant distances and can penetrate physical barriers such as walls and buildings more effectively. Additionally, these frequencies experience less interference compared to those in the heavily congested 2.4-GHz band, which is commonly used by wireless devices.

In the United States, the 900 MHz band is a versatile frequency range that is utilized by various services, with the FCC overseeing its allocation and regulation.

In the European Union, the 868 MHz frequency is designated by ETSI as the Sub-Gig frequency.

In summary, if an application demands high data rates and more bandwidth in urban or densely populated areas where interference management is feasible, the 2.4 GHz frequency is a suitable choice. On the other hand, for applications requiring long-range communication and better obstacle penetration, particularly in rural or industrial settings with fewer regulatory constraints, a sub-GHz frequency (<1 GHz) is a better option.

Installation Recommendations:

With the many factors that affect and/or interrupt a wireless signal such as walls, glass, metal, objects, and people, it is highly recommended to:

- Install devices a minimum of 9.8 ft. (3m) above audiences and/or ground level where practical.
- Adjust the wireless antenna in a vertical upright position
- Position devices in direct line of sight of the controlling Aria device

Careful planning and testing of the selected installation location is critical to ensure optimum and reliable wireless operation.

**9.8 ft (3m)
Above Ground**

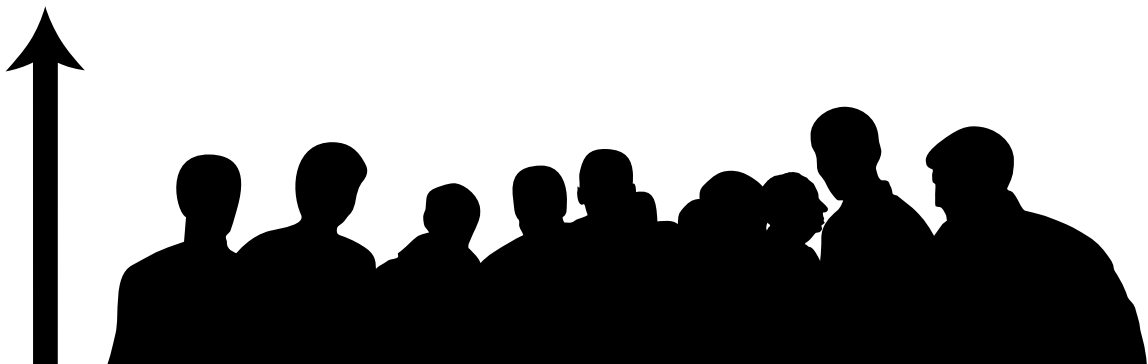

SYSTEM MENU

The fixture includes an easy to navigate system menu. The control panel (see image below) located on the front of the fixture, provides access to the main system menu and is where all necessary system adjustments are made to the fixture. During normal operation, pressing **ENTER** button once will access the fixture's main menu. Once in the main menu you can navigate through the different functions and access the submenus with the **UP** and **DOWN** buttons. Once you reach a field that requires adjusting, press the **ENTER** button to activate that field and use the **UP** and **DOWN** buttons to adjust the field. Pressing the **ENTER** button once more will confirm your setting. You may exit the main menu at any time without making any adjustments by pressing the **ENTER** button.

Display Shortcuts:

Power Off: Long press the **ENTER** button for 3s, activate battery mode

Power On: Long press the **ENTER** button for 10s, unlock display, show 10s countdown.

Long press the **UP** button and the **DOWN** button for 3s, disable Pan Tilt.

Long press the **BACK** button and the **ENTER** button for 5s, countdown 10 sec or Reset to Default.

NOTE: To access the LCD Menu Control Display via the internal battery, press and hold the **MODE/ESC** button for 10 seconds. The LCD Menu Control Display will shut **OFF** automatically about 1 minute from the last button press.

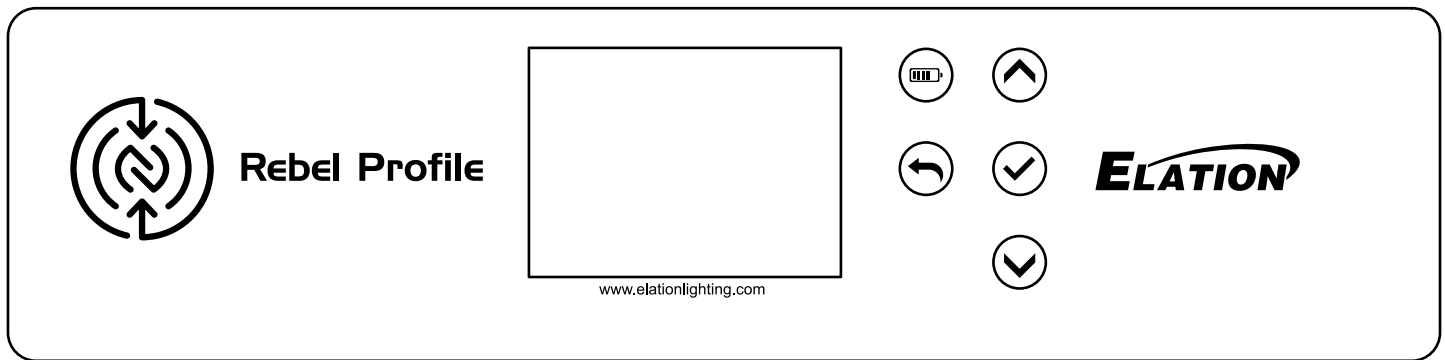

BATTERY

This unit features a dedicated internal battery that can be used to power the screen display. This allows the user to configure the device's channel mode, DMX address, or any other screen-accessible features without needing to power on the device or even connect it to a power source. To activate the display on battery power, press and hold the **ENTER** button for 3 seconds.



IMPORTANT: THIS FIXTURE IS EQUIPED WITH ARIA X2. ARIA'S WIRELESS FEATURES HAE BEEN SET TO OFF BY DEFAULT. ACTIVATE ARIA X2 AND BLUETOOTH IN THE SYSTEMS MENU TO TAKE ADVANTAGE OF ITS WIRELESS FEATURE SET FOR WIRELESS CONNECTIVITY AND OVER THE AIR SOFTWARE UPDATES.



AN ELATION C-LOADER CAN BE USED TO UPDATE THE FIXTURE TO THE LATEST SOFTWARE. SEE PAGE 41 FOR INSTRUCTIONS. TO ORDER THIS DEVICE, PLEASE CONTACT ELATION SUPPORT FOR FURTHER DETAILS.

**ELATION SERVICE USA - Monday - Friday 8:00am to 4:30pm PST
323-582-3322 | support@elationlighting.com**

**ELATION SERVICE EUROPE - Monday - Friday 08:30 to 17:00 CET
+31 45 546 85 63 | support@elationlighting.eu**

SYSTEM MENU

MAIN MENU	OPTIONS / VALUES (Default Settings in BOLD)		
DMX	DMX Address	001 - 512	
	DMX Mode	Standard, Extended	
	No DMX Status	Hold Last , Fade to Black, Sun Protection	
		Hibernation	Off, 1-99M (Default = 15 Min)
	Protocol	Select Signal	DMX , Art-Net, sACN, Aria In-DMX Out, DMX In - Aria Out
		Universe	1
		DHCP	Off/On
		IP Address	2.x.x.x
		Subnet Mask	255.0.0.0
		Ethernet DMX Out	Off/On
	Aria	Enable Aria	Off / On
		Frequency	2.4Ghz / Sub Gig- US / Sub Gig- EU
		2.4Ghz Chan	00 -15
		Sub Gig Chan	00 -09
		Enable Mesh	Off / On
Enable Bluetooth	Off / On		
Control	Manual Control	Dimmer 0% - 100% , Pan, Tilt, ...	
	Reset	All, Pan Tilt, Color, Gobo, Shutter, Others	
	Self Test	All, Dimmer, Movement, Color Mix, Gobo, Beam	
Settings	Fan Mode	Mute, Studio, Low, High, Auto	
	Movement	Pan Invert	Off/On
		Tilt Invert	Off/On
		Pan Tilt Speed	Smooth/ Fast
		Follow Spot	Off/On
		Pan Tilt Feedback	Off/On
	Dimmer Curve	Linear, Squre, Square Inverse, S-Curve	
	Dimmer Mode	Standard, Stage, TV, Architectural, Theatre, Stage 2	
		Dim Speed	0s - 10s
	LED Refresh Rate	900Hz - 1500Hz (1200Hz), 2500Hz, 4000Hz, 5000Hz, 6000Hz, 10KHz, 15KHz, 20KHz, 25KHz	
	LED Power Limit	50%, 60%, 70%, 80%, 90%, 100%	
	Display	Screen Delay	10s - 5min (Default = 1 min)
Screen Lock		Off , 10s - 5 min	
Auto Rotate		Off/On	
Reset Defaults	Yes / No		
Information	Time	Current Time, Total Run Time, Last Run Time, LED Time	
	Temperature	Head, Base, LED	
	Humidity	Head, Base	
	Fan	Fan xx, ...	
	DMX Values	Pan, Tilt, ...	
	Product IDs	RDM UID	
	Error Logs	Fixture Errors	
Software Version	Vx.x		
Service (Passcode 50)	Calibration	Dimmer, Pan, Tilt, ...	
	Reset Last Run	Yes / No	
	Reset Error Logs	Yes / No	

Display Shortcuts

Power On	Enter (10s)	Unlock display, show 10s countdown
	Up+Down (3s)	Disable Pan Tilt
	Back+Enter (10s)	Countdown 10 sec
		Reset Default (no/yes)

SUN PROTECTION MODE

The fixture incorporates an automatic protection from harmful sunlight, which can damage a fixture's internal components from extended exposure. Fixtures use an internal sensor to determine their physical orientation, then reorient the fixture towards the ground to prevent sunlight from entering the lens.

This automatic feature only works when the fixture is powered. If the fixture is unpowered during setup, it is necessary to manually reorient the lenses away from the sun, and aim them towards the ground. Even a few minutes of sun exposure can cause damage inside the fixture.

The Sun Protection setting is accessed via the "No DMX Status" menu.

The automatic sun protection positioning is activated under the following conditions:

1. Power on without DMX signal: the fixture always starts in sun protection mode.
2. No DMX Status "Sun Protection": the fixture enters sun protection mode after approximately 3 minutes.
3. Remote DMX control: the sun protection position can be **temporarily** activated from the lighting console without the need to create a custom position preset. The fixture senses the correct ground orientation. This means that fixtures already facing the ground may not move their heads.

Hold "Sun Protect Position" for 3s to set the fixture to the sun protection position.

Sun protection status displays as "**Sun Protection: Active**".

The sun protection position deactivates under the following conditions:

1. Connect DMX signal.
2. Remote DMX control: Hold "Sun Protection Off" for 3s.

To avoid harsh or jarring movements, the sun protection position always uses a 5-second fade time when it is activated or deactivated.

HIBERNATION MODE

To reduce wear on the fixture and its components, this mode disables motors and most electronics. Set the hibernation mode countdown time in the Display Menu: "Status Settings / Personality / Hibernation". Hibernation can be fully disabled.

The hibernation mode activates under the following conditions:

1. Loss of DMX: the fixture enters hibernation after the timeout expires. Default is 15 minutes.
2. Remote DMX control: Hold "Hibernate Fixture" for 3s

The hibernation mode deactivates under the following conditions:

1. Connect DMX Signal
2. Remote DMX control: Hold "Hibernate Off" for 3s

The fixture will perform a full calibration cycle, then assume the current DMX status.

Please note that the Hibernation does not change the PT position of the fixtures, allowing the user to set the desired position and then issue the Hibernate command.

To ensure the fixture is protected from harmful sunrays it is recommended to either leave the "No DMX Status" in "Sun Protection" (so the fixture is already in the correct position after 3 minutes of DMX loss) or set the fixture to a safe Tilt position manually first before hibernation.

Burn and heat damage to the fixture's interior components due to external light sources (sun or other fixtures shining into the lens) is never covered under the manufacturers warranty.

FAN MODES AND LOW NOISE OPERATION

This fixture is a high-performance fixture suited for many applications. For noise critical environments like Theater, Opera or Orchestra Halls, it offers various operation modes to remove any distraction for the audience and performers. Modes can be changed remotely via the DMX control channel, allowing the fixture to offer high output or quiet operation at a moment's notice. All modes smoothly transition over a brief period, preventing unwanted attraction to the fixture.

Fan Modes

Auto – The default AUTO mode ensures optimal performance of the fixture. Fans only run at the speeds needed to keep the LED engine within a safe temperature range. They will turn off if possible, for example when the fixture is dimmed to a low intensity. Fans sense the ambient and fixture temperature, and will at all times try to keep noise levels at a minimum. The fixture output will only reduce when the LED engine cannot be cooled down to its safe operating range due to high ambient temperature. **Auto is the recommend mode for daily operation of the Rebel Profile.**

Low – In this mode the fixture reduces fan speeds throughout for a lower noise profile of the fixture. This mode should be sufficient for most uses where lower noise is required. The fixture output is reduced to about 80%.

High – This mode is only required in very high ambient temperatures when automatic fan speed adjustments are not desired. High Fan Speed will cool the fixture most efficiently. This mode will increase wear on the fans and should only be utilized in exceptional circumstances. Fans will always run, even if the fixture is dimmed. Fixture output is kept at 100% unless the LED engine temperature is too high, at which point the fixture will reduce power carefully to ensure safe operation.

Low Noise Modes

For very critical situations, the fixture offers two additional low noise modes for silent operation. The fixture output will be reduced, but as the fixture has such an extremely high luminous flux, it still offers outstanding performance.

Studio – This mode reduces the fixture output to approximately 50%.

Mute – Running the fixture in MUTE mode reduces the fixture to about 25% output.

DIMMER MODE

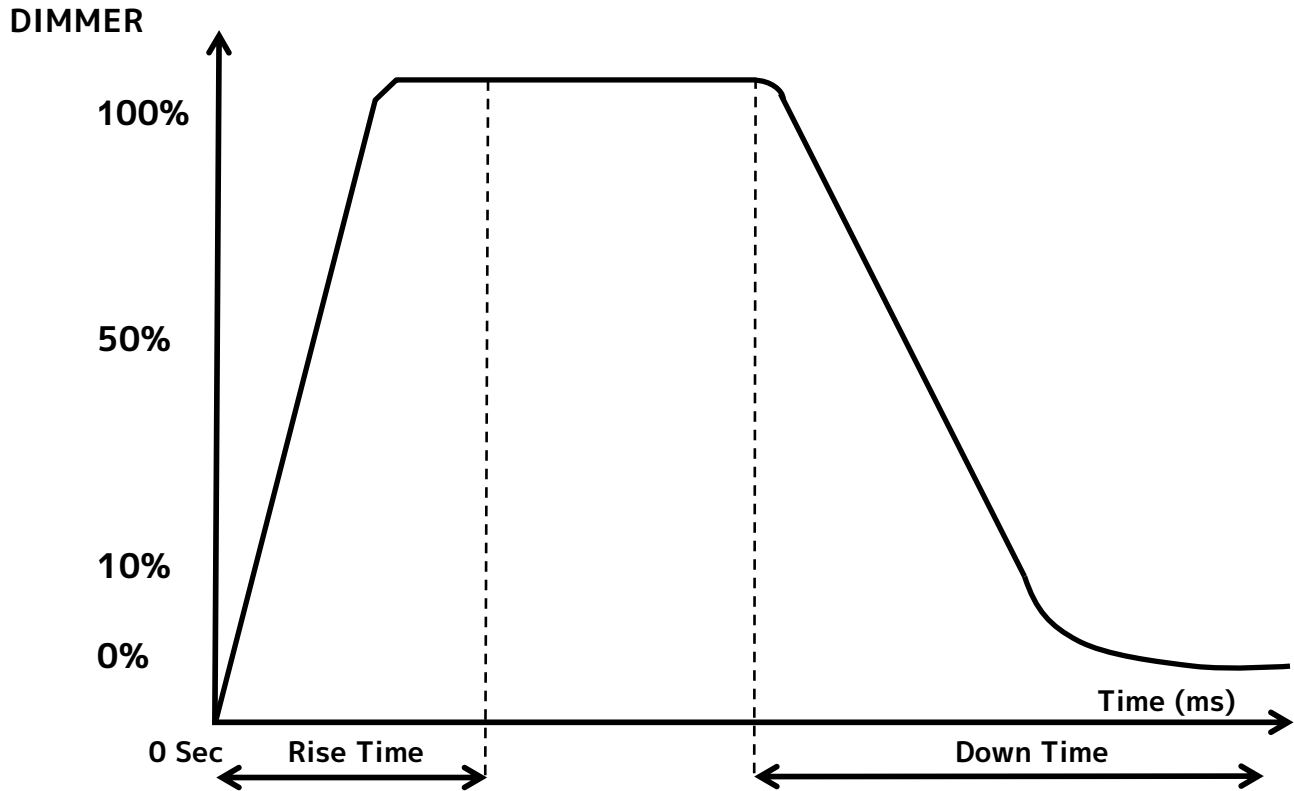

Dimming Curve Ramp Effect	0 sec Fade Time		1 sec Fade Time	
	Rise Time (ms)	Down Time (ms)	Rise Time (ms)	Down Time (ms)
Standard (default)	0	0	0	0
Stage	780	1100	1540	1660
TV	1180	1520	1860	1940
Architectural	1380	1730	2040	2120
Theatre	1580	1940	2230	2280
Stage 2	0	1100	0	1660

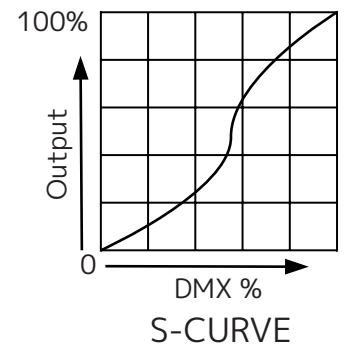
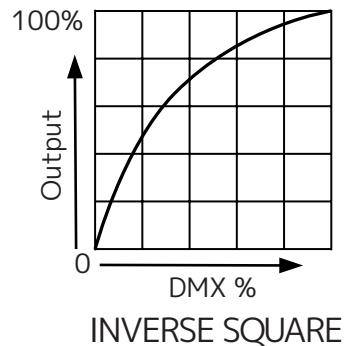
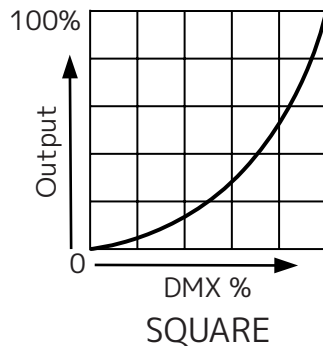
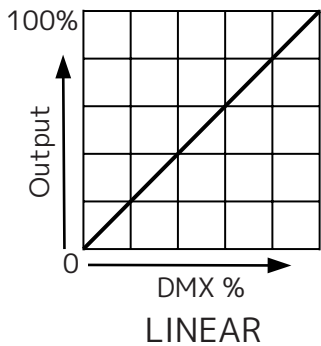

DMX TRAITS

MODE/CHANNEL		VALUE	FUNCTION	SNAP	DEFAULT
STANDARD	EXTENDED				
1	1	0-255	Pan		
			Left → Right		
2	2	0-255	Pan Fine		
			Fine Position		
3	3	0-255	Tilt		
			Forward → Backward		
4	4	0-255	Tilt Fine		
			Fine Position		
5	5		Pan Rotation		
		0-128	no function		
		128-189	Clockwise Fast → Slow		
		190-193	Stop		
		194-255	Counter-clockwise Slow → Fast		
6	6	0-255	Cyan		
			0 → 100%		
			SFX		
		0-170	0 → 100%		
		171-189	100% → 0%		
		190-221	Clockwise Fast → Slow		
		222-223	Stop		
224-255	Counter-clockwise Slow → Fast				
	7	0-255	Cyan Fine		
			Fine Saturation		
7	8	0-255	Magenta		
			0 → 100%		
			SFX		
		0-170	0 → 100%		
		171-189	100% → 0%		
		190-221	Clockwise Fast → Slow		
		222-223	Stop		
224-255	Counter-clockwise Slow → Fast				
	9	0-255	Magenta Fine		
			Fine Saturation		
8	10	0-255	Yellow		
			0 → 100%		
			SFX		
		0-170	0 → 100%		
		171-189	100% → 0%		
		190-221	Clockwise Fast → Slow		
		222-223	Stop		
224-255	Counter-clockwise Slow → Fast				
	11	0-255	Yellow Fine		
			Fine Saturation		

DMX TRAITS

MODE/CHANNEL		VALUE	FUNCTION	SNAP	DEFAULT
STANDARD	EXTENDED				
9	12	0-255	CTO		
			Open → 2700K		
	13	0-255	CTO Fine		
			Fine Saturation		
10	14		CMY Mix Mode	X	
		0-127	Full		
		128-255	SFX		
11	15		Color	X	
		0-5	Open		
		6-15	Color 1		
		16-31	Color 2		
		32-47	Color 3		
		48-63	Color 4		
		64-79	Color 5		
		80-95	Color 6		
		96-111	Color 7		
		112-127	Open		
			Scroll		
		128-189	Clockwise Fast → Slow		
		190-193	Stop		
194-255	Counter-clockwise Slow → Fast				
12	16		Rotating Gobo	X	
		0-9	Open		
		10-19	Gobo 1		
		20-29	Gobo 2		
		30-39	Gobo 3		
		40-49	Gobo 4		
		50-59	Gobo 5		
		60-69	Gobo 6		
		70-77	Gobo 7		
		78-93	Gobo 1 shake slow to fast		
		94-109	Gobo 2 shake slow to fast		
		110-125	Gobo 3 shake slow to fast		
		126-141	Gobo 4 shake slow to fast		
		142-157	Gobo 5 shake slow to fast		
		158-173	Gobo 6 shake slow to fast		
		174-189	Gobo 7 shake slow to fast		
			Scroll		
		190-221	Clockwise Fast → Slow		
		222-223	Stop		
224-255	Counter-clockwise Slow → Fast				

DMX TRAITS

Features subject to change without notice

MODE/CHANNEL		VALUE	FUNCTION	SNAP	DEFAULT
STANDARD	EXTENDED				
13	17		Rotating Gobo Index/Rotation		
		0-127	Index Position		
			Rotate		
		128-190	Clockwise Fast → Slow		
		191-192	Stop		
	193-255	Counter-clockwise Slow → Fast			
14	18	0-255	Rotating Gobo Index/Rotation Fine Fine Adjustment		
15	19		Fixed Gobo		
		0-5	Open		
		6-12	Gobo 1		
		13-19	Gobo 2		
		20-26	Gobo 3		
		27-33	Gobo 4		
		34-40	Gobo 5		
		41-47	Gobo 6		
		48-54	Gobo 7		
		55-61	Gobo 8		
		62-77	Gobo 1 Shake, slow to fast		
		78-93	Gobo 2 Shake, slow to fast		
		94-109	Gobo 3 Shake, slow to fast		
		110-125	Gobo 4 Shake, slow to fast		
		126-141	Gobo 5 Shake, slow to fast		
		142-157	Gobo 6 Shake, slow to fast		
		158-173	Gobo 7 Shake, slow to fast		
		174-189	Gobo 8 Shake, slow to fast		
			Scroll		
		190-221	Clockwise Fast → Slow		
222-223	Stop				
224-255	Counter-clockwise Slow → Fast				

DMX TRAITS

MODE/CHANNEL		VALUE	FUNCTION	SNAP	DEFAULT
STANDARD	EXTENDED				
16	20		Prism1	X	64
		0-5	Open		
		6-255	Prism 1		
17	21		Prism 1 Index/Rotation		
		0-127	Index Position		
			Rotate		
		128-189	Clockwise Fast → Slow		
		190-193	Stop		
		194-255	Counter-clockwise Slow → Fast		
	22	0-255	Prism 1 Index/Rotation Fine Fine Adjustment		
18	23		Prism2	X	64
		0-5	Open		
		6-255	Prism 2		
19	24		Prism 2 Index/Rotation		
		0-127	Index Position		
			Rotate		
		128-189	Clockwise Fast → Slow		
		190-193	Stop		
		194-255	Counter-clockwise Slow → Fast		
	25	0-255	Prism 2 Index/Rotation Fine Fine Adjustment		
20	26	0-255	Focus Infinity → Near		
21	27	0-255	Focus Fine Fine Adjustment		
22	28	0-255	Zoom Narrow → Wide		
23	29	0-255	Zoom Fine Fine Adjustment		
24	30		Strobe	X	
		0-31	Closed		
		32-63	Open		
		64-95	Strobe effect slow to fast		
		96-127	Open		
		128-159	Pulse Effect		
		160-191	Open		
		192-223	Random Slow → Fast		
224-255	Open				

DMX TRAITS

MODE/CHANNEL		VALUE	FUNCTION	SNAP	DEFAULT
STANDARD	EXTENDED				
25	31	0-255	Dimmer 0 → 100%		
26	32	0-255	Dimmer Fine Fine Adjustment		
	33		Dimmer Modes	X	
		0-20	Standard		
		21-40	Stage		
		41-60	TV		
		61-80	Architectural		
		81-100	Theatre		
		101-120	Stage 2		
			Dimmer Time		
		121	0s		
		122	0.1s		
		123	0.2s		
		124	0.3s		
		125	0.4s		
		126	0.5s		
		127	0.6s		
		128	0.7s		
		129	0.8s		
		130	0.9s		
		131	1.0s		
		132	1.5s		
		133	2.0s		
		134	3.0s		
		135	4.0s		
136	5.0s				
137	6.0s				
138	7.0s				
139	8.0s				
140	9.0s				
141	10s				
142-255	Idle				
27	34		Iris		
		0-191	Open → Close		
		192-223	Pulse Closing fast → slow		
		224-255	Pulse Opening slow → fast		
28	35	0 – 255	Frost (Light) Open → Max		
29	36	0 – 255	Frost (Wash) Open → Max		
30	37		Animation		
		0-7	Open		
		8-255	Animation Min → Max		
31	38		Animation Index		64
		0-127	Position		
			Scroll		
		128-189	Clockwise Fast → Slow		
		190-193	Stop		
194-255	Counter-clockwise Slow → Fast				

DMX TRAITS

MODE/CHANNEL		VALUE	FUNCTION	SNAP	DEFAULT
STANDARD	EXTENDED				
32	39	0-255	Blade 1 A		
			Open → Closed		
	40	0-255	Blade 1 A Fine		
			Fine Adjustment		
33	41	0-255	Blade 1 B		
			Open → Closed		
	42	0-255	Blade 1 B Fine		
			Fine Adjustment		
34	43	0-255	Blade 2 A		
			Open → Closed		
	44	0-255	Blade 2 A Fine		
			Fine Adjustment		
35	45	0-255	Blade 2 B		
			Open → Closed		
	46	0-255	Blade 2 B Fine		
			Fine Adjustment		
36	47	0-255	Blade 3 A		
			Open → Closed		
	48	0-255	Blade 3 A Fine		
			Fine Adjustment		
37	49	0-255	Blade 3 B		
			Open → Closed		
	50	0-255	Blade 3 B Fine		
			Fine Adjustment		
38	51	0-255	Blade 4 A		
			Open → Closed		
	52	0-255	Blade 4 A Fine		
			Fine Adjustment		
39	53	0-255	Blade 4 B		
			Open → Closed		
	54	0-255	Blade 4 B Fine		
			Fine Adjustment		
40	55		Framing Index		127
		0-126	Min (-60°)		
		127-128	Parallel (0°)		
		129-255	Max (+60°)		
	56	0-255	Framing Index Fine		
			Fine Adjustment		
41	57		Pan / Tilt Speed	X	
		0-225	Max → Min Speed		
		226-235	Blackout by movement		
		236-245	Blackout by wheel changes		
		246-255	No function		

DMX TRAITS

MODE/CHANNEL		VALUE	FUNCTION	SNAP	DEFAULT
STANDARD	EXTENDED				
42	58		Control	X	
		0-19	Wheel Snap		
		20-29	Color Wheel Fade		
		30-39	Color/Gobo Wheel Fade		
			Fan Mode		
		40-44	Mute		
		45-49	Studio		
		50-59	Low		
		60-69	High		
		70-79	Auto		
			Reset		
		80-84	All		
		85-87	Pan / Tilt		
		88-90	Gobo		
		91-93	Focus and Zoom		
		94-96	Others		
		97-99	Idle		
			Refresh Rate (Hz)		
		100	900		
		101	910		
		102	920		
		103	930		
		104	940		
		105	950		
		106	960		
		107	970		
		108	980		
		109	990		
		110	1000		
		111	1010		
		112	1020		
113	1030				
114	1040				
115	1050				
116	1060				
117	1070				
118	1080				
119	1090				
120	1100				
121	1110				
122	1120				
123	1130				
124	1140				
125	1150				

DMX TRAITS: CHANNEL FUNCTIONS & VALUES

MODE/CHANNEL		VALUE	FUNCTION	SNAP	DEFAULT
STANDARD	EXTENDED				
42	58		Refresh Rate (Hz)	X	
		126	1160		
		127	1170		
		128	1180		
		129	1190		
		130	1200 (default)		
		131	1210		
		132	1220		
		133	1230		
		134	1240		
		135	1250		
		136	1260		
		137	1270		
		138	1280		
		139	1290		
		140	1300		
		141	1310		
		142	1320		
		143	1330		
		144	1340		
		145	1350		
		146	1360		
		147	1370		
		148	1380		
		149	1390		
		150	1400		
		151	1410		
		152	1420		
		153	1430		
		154	1440		
		155	1450		
		156	1460		
157	1470				
158	1480				
159	1490				
160	1500				
161	2500				
162	4000				
163	5000				
164	6000				
165	10000				
166	15000				
167	20000				
168	25000				

DMX TRAITS: CHANNEL FUNCTIONS & VALUES

MODE/CHANNEL		VALUE	FUNCTION	SNAP	DEFAULT
STANDARD	EXTENDED				
		169-172	Idle	X	
		173-174	Hibernation Off		
		175-176	Hibernation		
		177-178	Sun Protection On		
		179-180	Sun Protection Off		
		181-190	Pan Tilt Smooth		
		191-200	Pan Tilt Fast		
			Dimmer Curves		
		201-210	Linear		
		211-220	Square		
		221-230	Inverse Square		
		231-240	S-Curve (Default)		
		241-249	Idle		
		250-251	Display Off		
		252-253	Display On		
		254-255	Idle		

REMOTE DEVICE MANAGEMENT (RDM)

NOTE: In order for RDM to work properly, RDM enabled equipment must be used throughout the entire system, including DMX data splitters and wireless systems.

Remote Device Management (RDM) is a protocol that sits on top of the DMX512 data standard for lighting, allowing the DMX systems of the fixtures to be modified and monitored remotely. This protocol is ideal for instances in which a unit is installed in a location that is not easily accessible.

With RDM, the DMX512 system becomes bi-directional, allowing a compatible RDM enabled controller to send out a signal to devices on the wire, as well as allowing the fixture to respond (known as a GET command). The controller can then use its SET command to modify settings that would typically have to be changed or viewed directly via the unit's display screen, including the DMX Address, DMX Channel Mode, and Temperature Sensors.

FIXTURE RDM INFORMATION:

RDM Code	Device ID	Device Model ID	Personality ID
22A6	005A00-FFFF	005A	Standard (1) Extend (2)

Please be aware that not all RDM devices support all RDM features, and therefore it is important to check beforehand to ensure that the equipment that you are considering includes all of the features that you require.

The following parameters are accessible in RDM on this device:

[0x0011] Proxied Device Count	[0x0601] Tilt Invert
[0x0200] Sensor Definition	[0x0602] Pan Tilt Swap
[0x0201] Sensor Value	[0x0500] Display Invert
[0x0080] Device Model Description	[0x0501] Display Level
[0x0081] Manufacturer Label	[0x0603] Realtime Clock
[0x0082] Device Label	[0x1010] Power State
[0x00E0] DMX Personality	[0x1031] Preset Playback
[0x00E1] DMX Personality Description	[0x0122] Default Slot Value
[0x0400] Device Hours	[0x00B0] Language
[0x0015] Comms Status	[0x00A0] Language Capabilities
[0x0031] Status ID Description	[0x00C2] Boot Software Version Label
[0x0032] Clear Status ID	[0x00C1] Boot Software Version ID
[0x0405] Device Power Cycles	[0x0070] Product Detail ID List
[0x0600] Pan Invert	[0x0030] Status Messages

MAINTENANCE GUIDELINES



DISCONNECT POWER BEFORE PERFORMING ANY MAINTENANCE!

CLEANING

Frequent cleaning is recommended to ensure proper function, optimized light output, and an extended life. The frequency of cleaning depends on the environment in which the fixture operates: damp, smoky or particularly dirty environments can cause greater accumulation of dirt on the fixture's optics. Periodically clean the external lens surface with a soft cloth to avoid dirt/debris accumulation. **NEVER** use alcohol, solvents, or ammonia-based cleaners.

MAINTENANCE

Regular inspections are recommended to ensure proper function and extended life. There are no user serviceable parts inside this fixture. Please refer all other service issues to an authorized Elation service technician. Should you need any spare parts, please order genuine parts from your local Elation dealer.

Please refer to the following points during routine inspections:

- A detailed electric check by an approved electrical engineer every three months, to make sure the circuit contacts are in good condition and prevent overheating.
- Be sure all screws and fasteners are securely tightened at all times. Loose screws may fall out during normal operation, resulting in damage or injury as larger parts could fall.
- Check for any deformations on the housing, color lenses, rigging hardware, and rigging points (ceiling, suspension, trussing). Deformations in the housing could allow for dust to enter into the fixture. Damaged rigging points or unsecured rigging could cause the fixture to fall and seriously injure a person(s).
- Electric power supply cables must not show any damage, material fatigue or sediments. **NEVER** remove the ground prong from the power cable.

FIXTURE DISASSEMBLY

The following points should be observed after performing any maintenance procedure that requires disassembly of the unit:

- After the unit has been reassembled, open the valve and allow the unit to run for approximately 2 hours in order to dry out any moisture that has been trapped inside the fixture. The process should continue until indicated humidity drops below 15% for the head and 30% for the base.
- Once this has been achieved, the light can be switched off, but the unit should remain connected to power so that the cooling fan can cool down the unit. Please note that allowing cool down time should **ALWAYS** be done after lamp operation.
- Some units may require partial disassembly in order to gain access to the valve. Please contact Elation service for information regarding the location and access procedure for the valve on your specific unit model.

ERROR CODES

Error Codes subject to change without notice	
ERROR CODES	DESCRIPTION
Pan	Movement is not located in the default position after the reset. These messages will appear after a fixture reset if the magnetic-indexing circuit malfunctions (sensor failed, or magnet is missing) or there is a motor failure (defective motor or a defective motor IC drive on the main PCB). This error may also be displayed if the head/yoke was blocked during a reset function.
Tilt	
Cyan	Movement is not located in the default position after the reset. These messages will appear after a fixture reset if the magnetic-indexing circuit malfunctions (sensor failed, or magnet is missing) or there is a motor failure (defective motor or a defective motor IC drive on the main PCB).
Magenta	
Yellow	
CTO	
ColorWheel	
RotGobo	
GoboRot	
FixedGobo	
Animation	
AnimationRot	
Focus	
Zoom	
Prism1	
Prism1Rot	
Prism2	
Prism2Rot	
Blade	These messages will appear if there is a temperature and/or fan malfunction.
LED Fan1	
LED Fan2	
LED Fan3	
LED Fan4	
LED Fan5	
LED Fan6	
GoboFan	
Blade Fan	
HeadFan1	
HeadFan2	
BaseFan1	
BaseFan2	
LedTemp	
BaseTemp	

SOFTWARE UPDATES



**ONLY QUALIFIED TECHNICIANS SHOULD PERFORM THIS FUNCTION!
NOTE ALL MENU SETTINGS BEFORE UPDATING SOFTWARE!
FIXTURE SOFTWARE CAN NOT BE DOWNGRADED!
DOWNLOAD FIXTURE SOFTWARE TO PC ONLY! (NO MAC SUPPORT)
PLEASE CONTACT ELATION SERVICE FOR FURTHER INFORMATION.**

C-LOADER II

An Elation C-Loader II can be used to update the fixture to the latest software. Please visit the C-Loader II product page at the Elation web site and download the product manual for step by step instructions.

<https://www.elationlighting.com/c-loader-software-uploader>

To order the C-Loader II uploader and the updated software for your fixture, please contact Elation support for details.

ELATION SERVICE USA - Monday - Friday 8:00am to 4:30pm PST
323-582-3322 | support@elationlighting.com

ELATION SERVICE EUROPE - Monday - Friday 08:30 to 17:00 CET
+31 45 546 85 63 | support@elationlighting.eu

SPECIFICATIONS

SOURCE

600W 6,500K Bright White Peak Field LED Engine
20,000 Hour Average LED Life*

*Test lab conditions. May vary depending on several factors including but not limited to: Environmental Conditions, Power/Voltage, Usage Patterns (On-Off Cycling), Control, and Dimming.

PHOTOMETRIC DATA

22000 Total Lumen Fixture Output
CRI 70+ (80 or 90 with HCRI Filter)
2:1 Hotspot Ratio
Zoom Range 3.5° - 51°
Beam Angle
Field Angle

EFFECTS

Motorized Zoom
4 Rotating Full Blackout Framing Blades
+/-60° Framing Module Index
Full 360° Bi-Directional Animation Wheel
4-Facet Round and 6 Facet Linear Rotating Prisms
2 Variable Frost Filters (Light and Wash)
Motorized Iris with Variable Pulse Effects
Variable 16-bit Dimming Curves
High Speed Electronic Shutter and Strobe
DMX Controllable LED Refresh Rate
Pan Angle: 540°
Tilt Angle: 270°
Continuous 360° Pan Rotation

COLOR

CMY Color Mixing
Linear CTO Color Correction (2400K)
7 Dichroic Colors, including CRI 80 and CRI90 filters

GOBOS

2 Gobo Wheels
7 Rotating Glass Gobos
8 Static Glass Gobos

CONTROL / CONNECTIONS

2 DMX Channel Modes
(5) Button Touch Control Panel
Full Color 180° Reversible LCD Menu Display
Hibernation Mode (Power Save)
Aria x2 Wireless Device Management
NFC Configuration
IP65 Locking 5pin XLR Connector In/Out
IP65 Locking RJ45 Ethernet Connector In/Out
IP65 Locking Power Connector In

SIZE / WEIGHT

Length: 15.65 in (398mm)
Width: 11.06 in (281mm)
Height: 26.2 in (666mm)
Center-to-Center Spacing: 23.2 in (589mm)
Weight: 66 lbs. (29.9 kg)

ELECTRICAL

AC 100-240V 50/60Hz
Max Power Consumption: 950W
-4° to 113°F (-20°C to 45°C)
3509 BTU/hr (+/- 10%)

INCLUDED ITEMS

Omega Brackets (x2)
Safety Cable
IP65 Rated Locking Power Cable

APPROVALS / RATINGS

CE | cETLus | FCC | UKCA | IP65



DIMENSIONS

*Drawings not to scale. Specifications and improvements in the design of this unit and this manual are subject to change without notice.

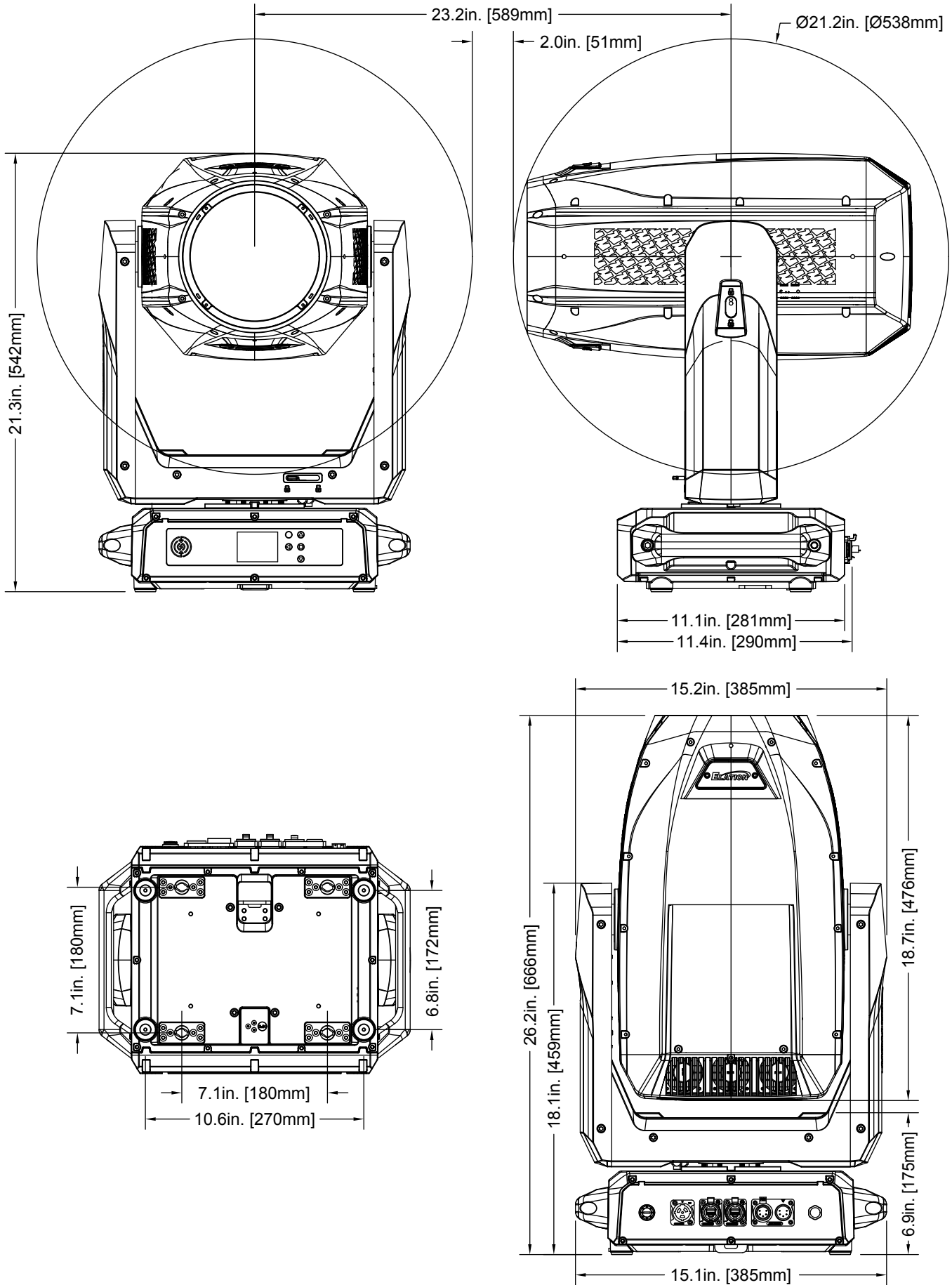

OPTIONAL ACCESSORIES

ORDER CODE	ITEM
TRIGGER CLAMP	Heavy Duty Wrap Around Hook Style Clamp
SIP126	5 ft. (1.5m) IP65 Twist Lock Power Link Cable
TOU027	5 ft. (1.5m) 5pin PRO DMX Cable
	Additional Cable Lengths Available

FCC STATEMENT

This device complies with Part 15 of the FCC Rules. Operation is subject to the following two conditions: (1) this device may not cause harmful interference, and (2) this device must accept any interference received, including interference that may cause undesired operation.

FCC RADIO FREQUENCY INTERFERENCE WARNINGS & INSTRUCTIONS

This product has been tested and found to comply with the limits as per Part 15 of the FCC Rules. These limits are designed to provide reasonable protection against harmful interference in a residential installation. This device uses and can radiate radio frequency energy and, if not installed and used in accordance with the included instructions, may cause harmful interference to radio communications. However, there is no guarantee that interference will not occur in a particular installation. If this device does cause harmful interference to radio or television reception, which can be determined by turning the device off and on, the user is encouraged to try to correct the interference by one or more of the following methods:

- Reorient or relocate the device.
- Increase the separation between the device and the receiver.
- Connect the device to an electrical outlet on a circuit different from which the radio receiver is connected.
- Consult the dealer or an experienced radio/TV technician for help.

Energy Saving Matters (EuP 2009/125/EC)

Saving electric energy is a key to help protecting the environment. Please turn off all electrical products when they are not in use. To avoid power consumption in idle mode, disconnect all electrical equipment from power when not in use. Thank you!



