

# **ELATION**<sup>®</sup>

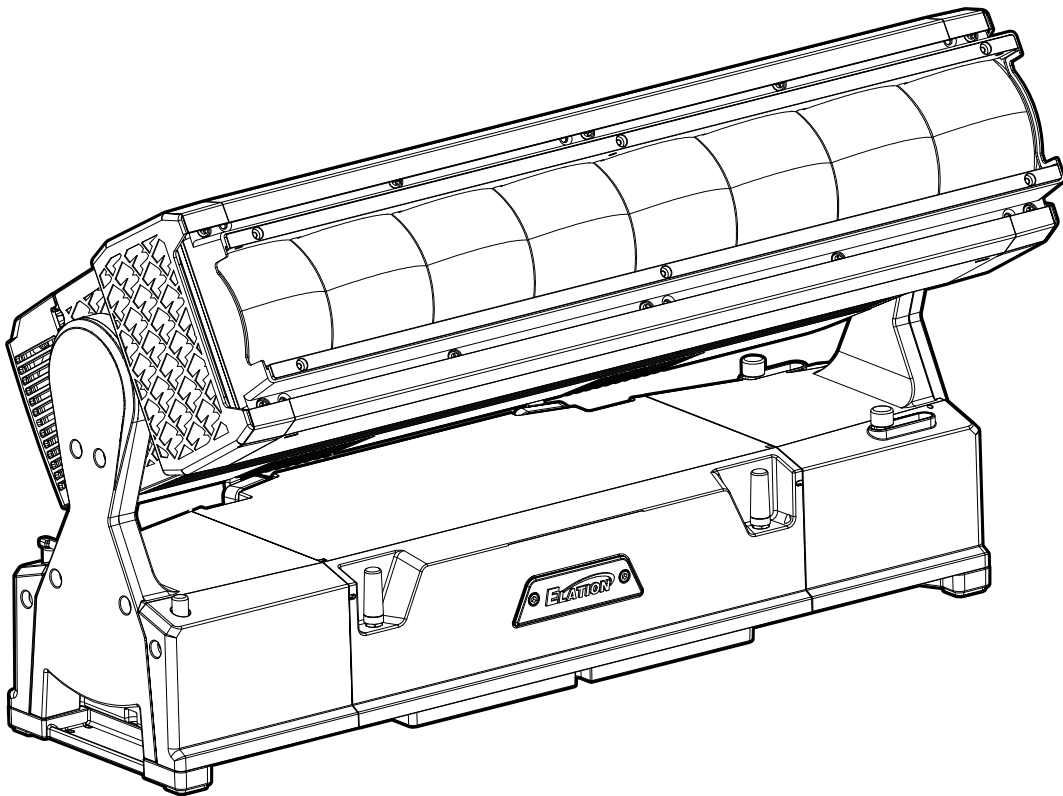

**REBEL<sup>™</sup> LINE 8**  
user manual

©2026 ELATION PROFESSIONAL all rights reserved. Information, specifications, diagrams, images, and instructions herein are subject to change without notice. ELATION PROFESSIONAL logo and identifying product names and numbers herein are trademarks of ELATION PROFESSIONAL. Copyright protection claimed includes all forms and matters of copyrightable materials and information now allowed by statutory or judicial law or hereinafter granted. Product names used in this document may be trademarks or registered trademarks of their respective companies and are hereby acknowledged. All non-ELATION brands and product names are trademarks or registered trademarks of their respective companies.

**ELATION PROFESSIONAL** and all affiliated companies hereby disclaim any and all liabilities for property, equipment, building, and electrical damages, injuries to any persons, and direct or indirect economic loss associated with the use or reliance of any information contained within this document, and/or as a result of the improper, unsafe, insufficient and negligent assembly, installation, rigging, and operation of this product.

**Elation Professional USA | 6122 S. Eastern Ave. | Los Angeles, CA. 90040**

323-582-3322 | [www.elationlighting.com](http://www.elationlighting.com) | [info@elationlighting.com](mailto:info@elationlighting.com)

**Elation Professional B.V. | Junostraat 2 | 6468 EW Kerkrade, The Netherlands**

+31 45 546 85 66 | [www.elationlighting.eu](http://www.elationlighting.eu) | [info@elationlighting.eu](mailto:info@elationlighting.eu)

**Elation Professional Mexico | AV Santa Ana 30 | Parque Industrial Lerma, Lerma, Mexico 52000**

+52 (728) 282-7070

## DOCUMENT VERSION



Due to additional product features and/or enhancements, an updated version of this document may be available online. Please scan the QR Code with your mobile device or visit [www.elationlighting.com](http://www.elationlighting.com) for the latest revision/update of this manual, before installation and/or programming.

Date	Document Version	SoftwareVersion ≥	DMX Channel Modes	Notes
03/09/2026	1.0	V1.0.0	22/30/70	Initial Release
04/29/2026	1.1	N/C	No Change	Updated: Dimensional Drawings, Specifications

# CONTENTS

<b>General Information</b>	<b>4</b>
<b>IP55 Rated</b>	<b>5</b>
<b>Safety Guidelines</b>	<b>6</b>
<b>Overview</b>	<b>8</b>
<b>Custom Logo Plate Installation</b>	<b>9</b>
<b>Installation Guidelines</b>	<b>10</b>
<b>Accessory Installation</b>	<b>15</b>
<b>Aria Setup and Guidelines</b>	<b>17</b>
<b>System Menu</b>	<b>20</b>
<b>Sun Protection Mode   Hibernation Mode</b>	<b>22</b>
<b>Fan Modes and Low Noise Operation</b>	<b>23</b>
<b>Dimmer Modes and Dimmer Curves</b>	<b>24</b>
<b>Patching and FX Programming Guide</b>	<b>25</b>
<b>DMX Traits: Main</b>	<b>28</b>
<b>DMX Traits: RGBL Pixels</b>	<b>33</b>
<b>DMX Traits: SparkX Pixels</b>	<b>35</b>
<b>Pixel Grouping</b>	<b>36</b>
<b>Color FX Table</b>	<b>37</b>
<b>SparkX FX Table</b>	<b>43</b>
<b>Color Temperature</b>	<b>49</b>
<b>Virtual Colors</b>	<b>50</b>
<b>Remote Device Management (RDM)</b>	<b>51</b>
<b>Maintenance Guidelines</b>	<b>52</b>
<b>Error Codes</b>	<b>53</b>
<b>Software Updates</b>	<b>54</b>
<b>Specifications</b>	<b>55</b>
<b>Dimensional Drawings</b>	<b>56</b>
<b>Optional Accessories   FCC Statement</b>	<b>57</b>

# GENERAL INFORMATION

## FOR PROFESSIONAL USE ONLY

### INTRODUCTION

Please read and understand the instructions in this manual carefully and thoroughly before attempting to operate this device. These instructions contain important safety and use information.

### COOLING

After usage, the light engine may be switched off, but the fixture should remain connected to power in order to allow the fan time to cool down the fixture.

### UNPACKING

Every device has been thoroughly tested and has been shipped in perfect operating condition. Carefully check the shipping carton for damage that may have occurred during shipping. If the carton is damaged, carefully inspect the device for damage, and be sure all accessories necessary to install and operate the device have arrived intact. In the event damage has been found or parts are missing, please contact our customer support team for further instructions. Please do not return this device to your dealer without first contacting customer support. Please do not discard the shipping carton in the trash. Please recycle whenever possible.

### BOX CONTENTS

2x Omega Brackets  
2x Front Louver  
2x Diffusion Filter  
Blank Logo Plate  
Safety Cable  
IP65 Locking Power Cable  
Manual

### CUSTOMER SUPPORT

Contact ELATION Service for any product related service and support needs. Also visit [forums.elationlighting.com](https://forums.elationlighting.com) with questions, comments or suggestions.

**ELATION SERVICE USA - Monday - Friday 8:00am to 4:30pm PST**

**323-582-3322 | [support@elationlighting.com](mailto:support@elationlighting.com)**

**ELATION SERVICE EUROPE - Monday - Friday 08:30 to 17:00 CET**

**+31 45 546 85 63 | [support@elationlighting.eu](mailto:support@elationlighting.eu)**

**REPLACEMENT PARTS** please visit [parts.elationlighting.com](https://parts.elationlighting.com)

### LIMITED WARRANTY

For up-to-date warranty information regarding your device, please visit Elation's warranty information page online or scan the QR codes below.



**USA: <https://www.elationlighting.com/warranty-information>**



**EU: [https://www.elationlighting.eu/terms\\_and\\_conditions](https://www.elationlighting.eu/terms_and_conditions)**

It is strongly recommended to power the fixture down completely when not in use. Doing so will reduce wear on the fixture due to sustained or extended operational periods, thereby maximizing its operational lifespan.

# IP55 RATED

The **International Protection (IP)** rating system is commonly expressed as “**IP**” (Ingress Protection) followed by two numbers (i.e. IP55), where the numbers define the degree of protection. The first digit (Foreign Bodies Protection) indicates the extent of protection against particles entering the fixture, and the second digit (Water Protection) indicates the extent of protection against water entering the fixture. An IP55 rated lighting fixture is designed and tested to protect against limited dust ingress (5), and low-pressure water jets from any direction (5).

**NOTE: THIS FIXTURE IS INTENDED FOR TEMPORARY OUTDOOR USE ONLY! Permanent installation in an outdoor location may accelerate aging, potentially compromising the device’s IP55 rating and posing potential safety hazards and damage risks. Do not use this fixture in permanent outdoor applications.**

**Maritime/Seaside Environment Installations:** A maritime/seaside environment is adjacent to the sea and caustic to electronics through exposure to atomized salt water and humidity, whereas a coastal environment extends 5 miles inland.



**NOT suitable for maritime/seaside environment installations. Installing this fixture in a maritime/seaside environment may cause corrosion and/or excessive wear to the interior and/or exterior components of the fixture. Damages and/or performance issues resulting from installation in a maritime/seaside environment will void the manufacturer’s warranty, and will NOT be subject to any warranty claims and/or repairs.**

Maritime installations require additional preparation, and additional service intervals may be needed given the maritime use. In general, IP ratings presuppose freshwater conditions VS maritime conditions, which are typically more “caustic” to IP fixtures (both internally and externally). A duty-cycle may also be needed when units are not in use. During times of high humidity and colder temperatures, condensation may occur internally so the fixture may require a duty-cycle to bring it up to running temperature, allowing any accumulation of moisture to be expelled via the vent valve. Recommendations can change based on installation environmental circumstances. A waterproof dome or similar device is recommended for use in permanent outdoor installations. When using a dome, refer to manufacturer recommendations for duty-cycle.

**NOTE: NOT ALL FEATURES LISTED ARE AVAILABLE ON ALL FIXTURES; THE FOLLOWING INSTRUCTIONS MAY NOT APPLY. CONTACT SUPPORT FOR ADDITIONAL DETAILS.**

**Exterior Maintenance:** Inspect the exterior every 30-days. The unit must be powered off/disconnected. The chassis should be inspected for any signs of contaminants. Inspect optics to determine if the lens is obstructed, then clean optics and chassis accordingly. Based on initial finding, schedule maintenance accordingly, keeping in mind that exterior maintenance will be required. Even if the luminaires are NOT in use, maintenance will still be needed given its location (exterior use). The use of a durable type of wax on the chassis is recommended since it will help prevent contaminant build up. Inspect both power and data lines for any signs of contaminants or corrosion. Periodically reapplying di-electric grease, especially in coastal environments. If any signs of corrosion/contaminants are present, clean thoroughly, and/or replace connectors, then reapply di-electric grease. Typically, this should be done annually, or any time an opportunity presents itself. As a preventive measure, annual replacement of both vent valves is recommended. The vent valve membrane can become contaminated and/or clogged causing improper venting of humidity within the luminaire. Inspect all mounting hardware as a precaution

**Interior Maintenance:** Inspect the interior every 30-days. The unit must be powered off/disconnected.

- Inspect linear LED array and optics for dust or wear; clean as needed
- Inspect all fans, clean as needed, check rotation, check connections.
- Clean interior with low-volume compressed air, then clean optics prior to reassembly of covers.

Although the base has limited moving parts, inspect any internal wiring or components for wear. Remember to always perform an IP test anytime a cover is removed. There is no specific time frame regarding the routine replacement of parts such as PCBs or LEDs.

These items should only be replaced on an as-needed basis, except for cooling fans, which should be replaced once the luminaires reach 10,000-hours. This is a prophylactic measure intended to keep the unit running as cool as possible, ensuring proper function of all internal components. A complete service breakdown is available, please contact [service@elationlighting.com](mailto:service@elationlighting.com) for any needed parts or manuals.

# SAFETY GUIDELINES

This fixture is a sophisticated piece of electronic equipment. To guarantee a smooth operation, it is important to follow all instructions and guidelines in this manual. Elation Professional is not responsible for injury and/or damages resulting from the misuse of this fixture due to the disregard of the information printed in this manual. Only qualified and/or certified personnel should perform installation of this fixture and only the original rigging parts (omega brackets) included with this fixture should be used for installation. Any modifications to the fixture and/or the included mounting hardware will void the original manufacturer's warranty and increase the risk of damage and/or personal injury.

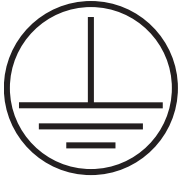

**PROTECTION CLASS 1 - FIXTURE MUST BE PROPERLY GROUNDED.**



**THERE ARE NO USER SERVICEABLE PARTS INSIDE THIS UNIT. DO NOT ATTEMPT ANY REPAIRS YOURSELF; DOING SO WILL VOID YOUR MANUFACTURER'S WARRANTY. DAMAGES RESULTING FROM MODIFICATIONS TO THIS FIXTURE AND/OR THE DISREGARD OF SAFETY INSTRUCTIONS AND GUIDELINES IN THIS MANUAL VOID THE MANUFACTURE'S WARRANTY AND ARE NOT SUBJECT TO ANY WARRANTY CLAIMS AND/OR REPAIRS.**



**DO NOT PLUG FIXTURE INTO A DIMMER PACK!  
NEVER OPEN THIS FIXTURE WHILE IN USE!  
UNPLUG POWER BEFORE SERVICING FIXTURE!  
NEVER TOUCH FIXTURE DURING OPERATION, AS IT MAY BE HOT!  
KEEP FLAMMABLE MATERIALS AWAY FROM FIXTURE!**

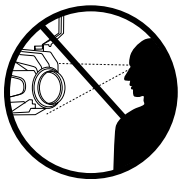

**NEVER LOOK DIRECTLY INTO THE LIGHT SOURCE!  
RETINA INJURY RISK - MAY INDUCE BLINDNESS!  
SENSITIVE PERSONS MAY SUFFER AN EPILEPTIC SHOCK!**



**MINIMUM DISTANCE TO OBJECTS/SURFACES MUST BE 1.6 FEET (0.5 METERS)  
MAXIMUM TEMP OF EXTERNAL SURFACE 176°F (80°C)  
MINIMUM DISTANCE OF INFLAMMABLE MATERIALS 1.6 FEET (0.5 METER)**

1. The light source in this luminaire should only be replaced by the manufacturer, their authorized service agent, or a similarly qualified individual.
2. Position the luminaire so that prolonged staring into it from a distance closer than 3.8 meters is unlikely.
3. Replace shields, lenses, or ultraviolet screens if they are visibly damaged—such as by cracks or deep scratches—to the extent that their effectiveness is compromised.
4. Replace the lamp if it becomes damaged or thermally deformed.
5. This luminaire is designed exclusively for professional use.

# SAFETY GUIDELINES

**DO NOT TOUCH** the fixture housing during operation. Turn OFF the power and allow approximately 15 minutes for the fixture to cool down before serving.

**DO NOT** shake fixture, avoid brute force when installing and/or operating fixture.

**DO NOT** operate fixture if the power cord is frayed, crimped, damaged and/or if any of the power cord connectors are damaged and do not insert into the fixture securely with ease.

**NEVER** force a power cord connector into the fixture. If the power cord or any of its connectors are damaged, replace it immediately with a new one of similar power rating.

**DO NOT** block any air ventilation slots.

All fan and air inlets must remain clean and never blocked.

Allow approx. 3.3' (1m) between fixture and other devices or a wall for proper cooling.

Always disconnect fixture from main power source before performing any type of service and/or cleaning procedure. Only handle the power cord by the plug end, never pull out the plug by tugging the wire portion of the cord.

During the initial operation of this fixture, a light smoke or smell may emit from the interior of the fixture. This is a normal process and is caused by excess paint in the interior of the casing burning off from the heat associated with the lamp and will decrease gradually over time.

Consistent operational breaks will ensure fixture will function properly for many years.

**ONLY** use the original packaging and materials to transport the fixture in for service.

## CONDENSATION AND MOISTURE INSPECTION

Before powering on the fixture, remove it from its packaging or road case in a controlled, dry environment. Carefully inspect for any visible damage from transport and for signs of condensation or moisture, which can form due to sudden temperature changes (e.g., moving from a cold storage area to a warm venue). Allow the unit to fully acclimate to the ambient temperature for at least 1-2 hours or until any condensation has completely evaporated to prevent potential electrical damage, short circuits, or corrosion. Do not operate the fixture if moisture is present, as this may cause irreversible harm and void the warranty. If issues persist, refer to the troubleshooting guide or contact technical support.

# OVERVIEW

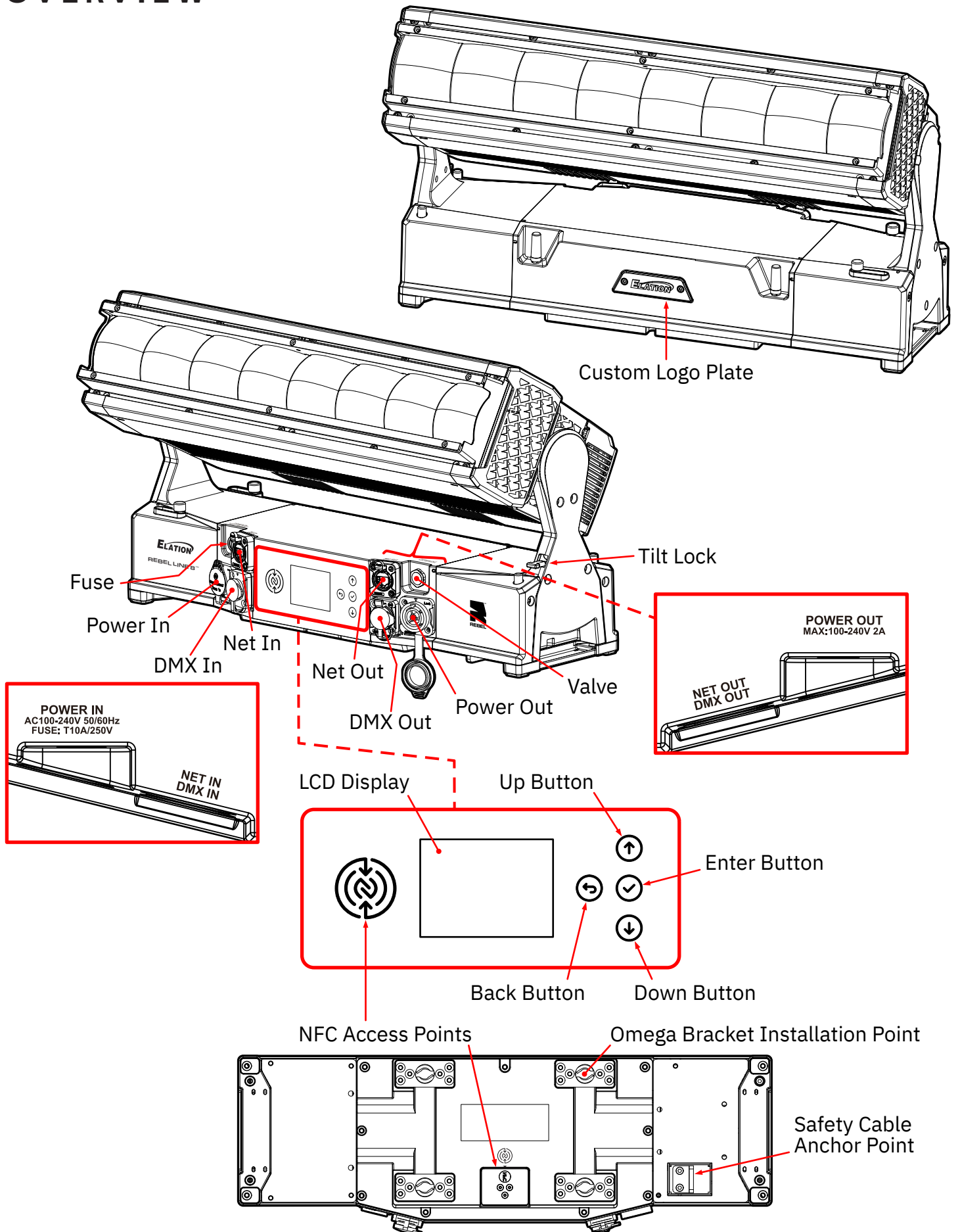

# CUSTOM LOGO PLATE INSTALLATION

To install a Logo Plate, ensure the fixture is powered off and disconnected. Locate and remove the existing Elation Logo Plate using a hex driver by unscrewing the two holding screws. Using the existing mounting screws, align the screw holes of the new badge with the mounting holes of the fixture.

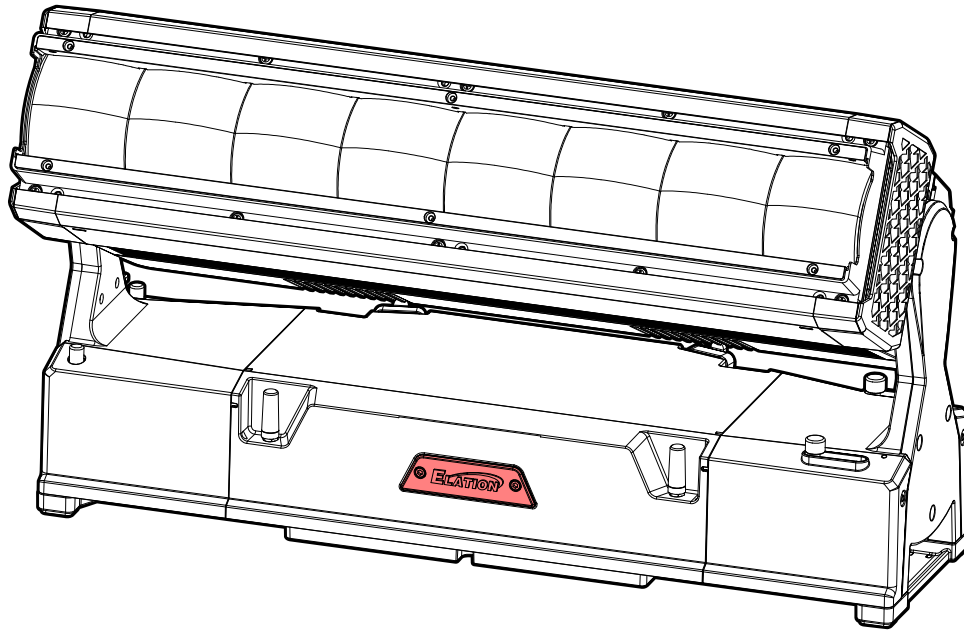

Gently screw the new Logo Plate into place, making sure it is flush and straight. Do not overtighten to prevent damage to the badge or the fixture.

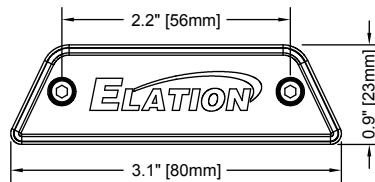

After installation, check that the Logo Plate does not interfere with any moving parts of the fixture. Once everything looks good, reconnect the power, turn on the fixture, and observe its operation to ensure the badge installation has not affected functionality. Periodically check the badge for tightness, particularly after transportation or if the fixture is frequently moved, to avoid it becoming loose over time.

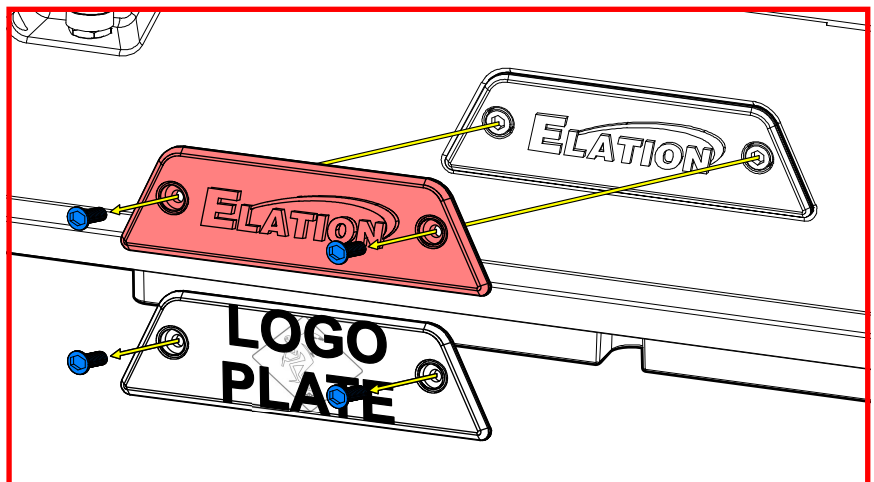

# INSTALLATION GUIDELINES



## **FLAMMABLE MATERIAL WARNING**

Keep fixture minimum 5.0 feet (1.5m) away from flammable materials and/or pyrotechnics.



## **ELECTRICAL CONNECTIONS**

A qualified electrician should be used for all electrical connections and/or installations.



**USE CAUTION WHEN POWER LINKING OTHER MODEL FIXTURES AS THE POWER CONSUMPTION OF OTHER MODEL FIXTURES MAY EXCEED THE MAX POWER OUTPUT ON THIS FIXTURE. CHECK SILK SCREEN FOR MAX AMPS.**



**MINIMUM DISTANCE TO OBJECTS/SURFACES  
MUST BE 1.6 FOOT (0.5 METERS)**



**MINIMUM DISTANCE OF INFLAMMABLE MATERIALS  
FROM THE SURFACE 1.6 FEET (0.5 METER)**



**MAXIMUM AMBIENT TEMPERATURE 194° F (90°C)**



**DO NOT INSTALL THE FIXTURE IF YOU ARE NOT QUALIFIED TO DO SO!**

Fixture **MUST** be installed following all local, national, and country commercial electrical and construction codes and regulations.

Before rigging/mounting the fixture to any metal truss/structure or placing the fixture on any surface, a professional equipment installer **MUST** be consulted to determine if the metal truss/structure or surface is properly certified to safely hold the combined weight of the fixture, clamps, cables, and accessories.

Overhead rigging requires extensive experience, including, amongst others, calculating working load limits, installation material being used, and periodic safety inspection of all installation material and the fixture. If you lack these qualifications, do not attempt the installation yourself. Improper installation can result in bodily injury.

Fixture ambient operating temperature range is **-4° to 113°F. (-20° to 45°C)**

Do not use the fixture under or above this temperature.

Fixture should be installed in areas outside walking paths, seating areas, or away from areas where unauthorized personnel might reach the fixture by hand.

**NEVER** stand directly below the fixture when rigging, removing or servicing.

Overhead fixture installation must always be secured with a secondary safety attachment, such as an appropriately rated safety cable.

Allow approximately 10 minutes for the fixture to cool down before servicing.

# INSTALLATION GUIDELINES

## OMEGA BRACKETS WITH CLAMP INSTALLATION

When mounting the fixture to a truss, be sure to secure an appropriately rated professional grade rigging clamp to the included **Omega Brackets** using an M10 screw fitted through the center hole of the **Omega Brackets**. Insert the Omega Brackets into the matching holes on the bottom of the fixture. Secure the Omega Brackets to the fixture by turning each quick-lock fastener ¼ turn clockwise; making sure the fastener is completely locked. Omega Brackets can be installed into the fixture base as illustrated below.

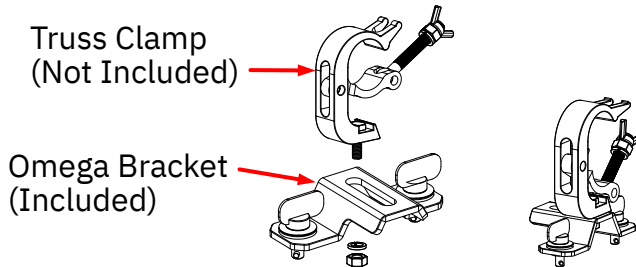

**\*SAFETY CABLE\***  
**ALWAYS ATTACH AN APPROPRIATELY RATED SAFETY CABLE WHENEVER INSTALLING THIS FIXTURE IN A SUSPENDED ENVIRONMENT TO ENSURE THE FIXTURE WILL NOT FALL IF THE CLAMP FAILS.**

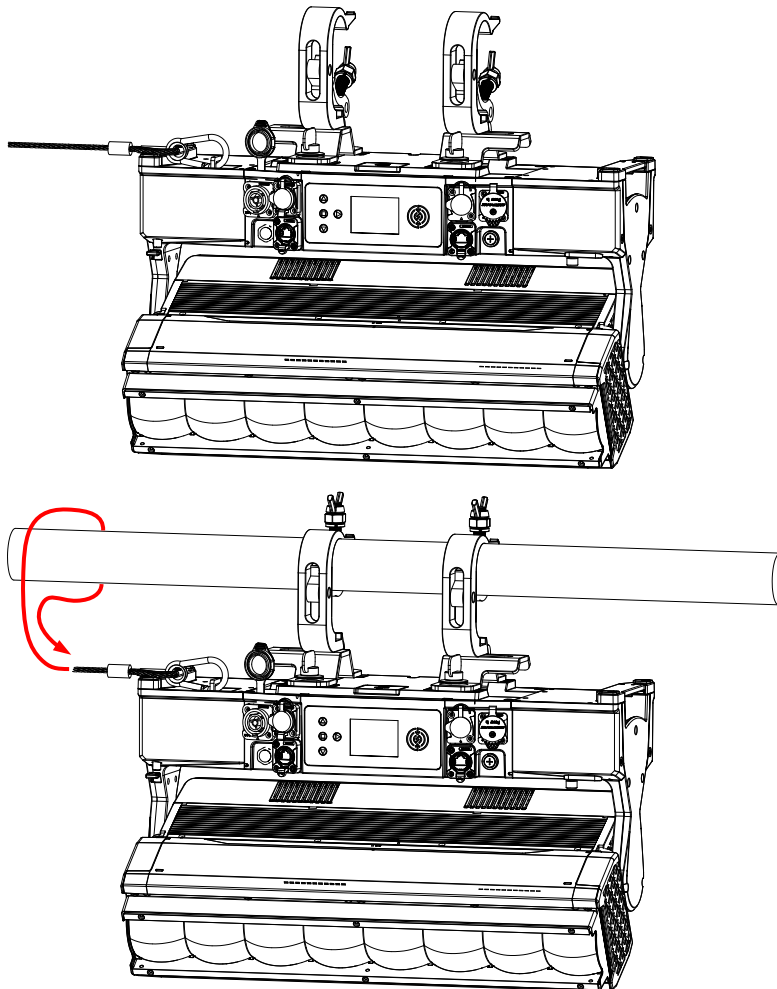

## RIGGING

Overhead rigging requires extensive experience, including among others, calculating working load limits, installation material being used, and periodic safety inspection of all installation material and the fixture. If you lack these qualifications, do not attempt the installation yourself. Improper installation can result in bodily injury. The fixture provides a built-in rigging point for a **SAFETY CABLE** (not included). Be sure to only use one of the designated rigging point for the safety cable and never secure a safety cable to a carrying handle. Connect the safety cable to the attachment point and route it around the truss.

# INSTALLATION GUIDELINES

## FIXTURE INSTALLATION

The Elation Rebel Line 8 is fully operational in three different mounting positions, hanging upside-down, mounted sideways on trussing, or set on a flat level surface. Be sure this fixture is kept at least (1.6' (0.5m)) away from any flammable materials (decoration etc.). Always use and install the supplied safety cable as a safety measure to prevent accidental damage and/or injury in the event the clamp fails. Never use the carrying handles for secondary attachment.

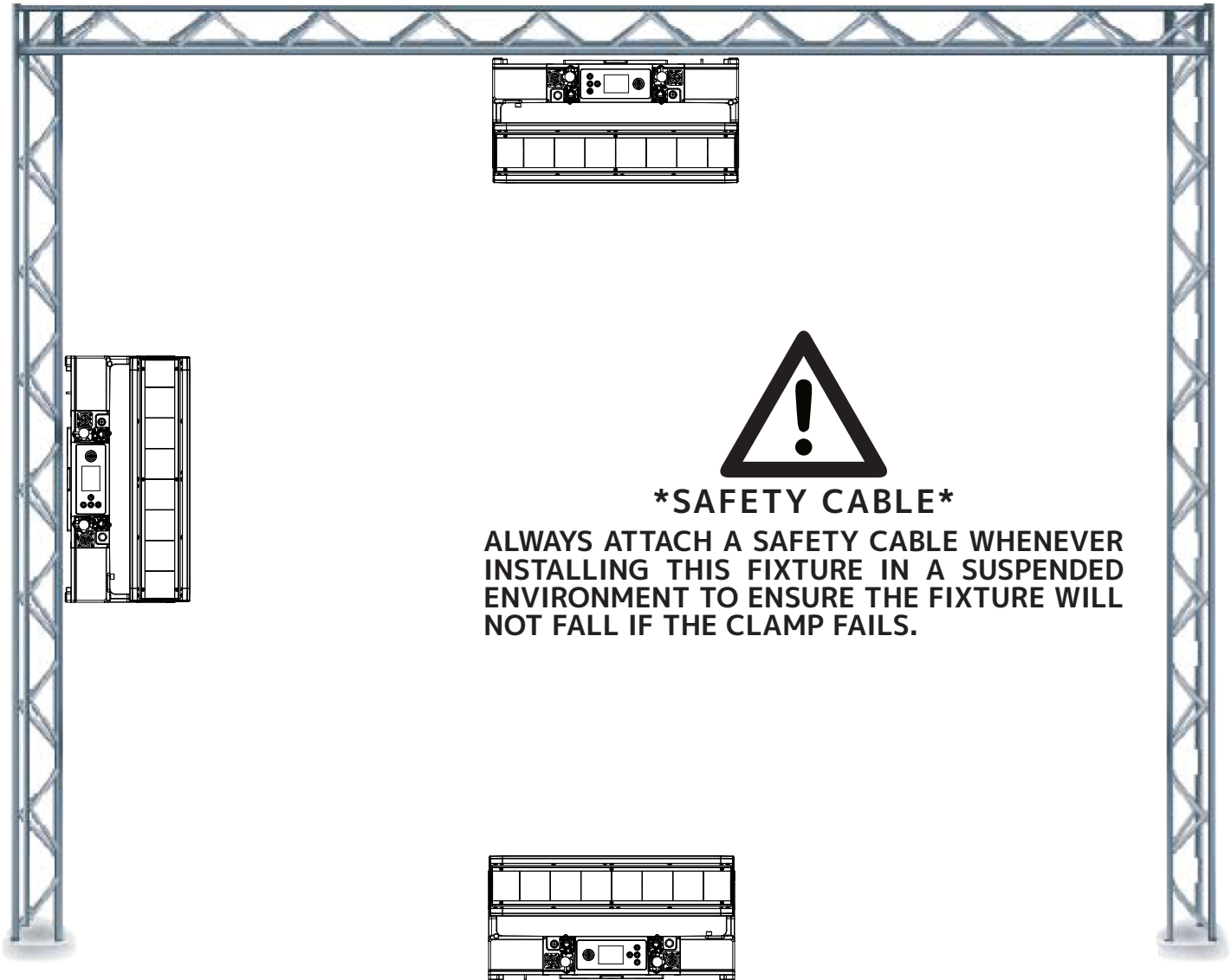

## ART-NET | sACN CONNECTION

When connecting fixture to a network switch to control multiple devices, a **Gigabit Ethernet Switch** that supports **IGMP (Internet Group Management Protocol)** is required. Using a **Gigabit Ethernet Switch** that does not support **IGMP** can cause erratic behavior of all connected devices to the switch. Click link below for more information about IGMP.

[https://en.wikipedia.org/wiki/Internet\\_Group\\_Management\\_Protocol](https://en.wikipedia.org/wiki/Internet_Group_Management_Protocol)

# INSTALLATION GUIDELINES

## ART-NET | sACN CONNECTION

When connecting fixture to a network switch to control multiple devices, a Gigabit Ethernet Switch that supports IGMP (Internet Group Management Protocol) is required. Using a Gigabit Ethernet Switch that does not support IGMP can cause erratic behavior of all connected devices to the switch. Click link below for more information about IGMP.

[https://en.wikipedia.org/wiki/Internet\\_Group\\_Management\\_Protocol](https://en.wikipedia.org/wiki/Internet_Group_Management_Protocol)

## POWER AND DATA CABLES



**ENSURE ALL CONNECTIONS AND END-CAPS ARE PROPERLY SEALED WITH DIELECTRIC GREASE (AVAILABLE AT MOST ELECTRICAL SUPPLIERS) TO PREVENT WATER CORROSION AND/OR ELECTRICAL SHORT CIRCUIT.**



**TO MAINTAIN THE IP55 RATING INTEGRITY OF THE FIXTURE, ALL CABLES MUST BE RUN TOWARDS THE GROUND TO PREVENT WATER ACCUMULATION AROUND THE CONNECTIONS.**

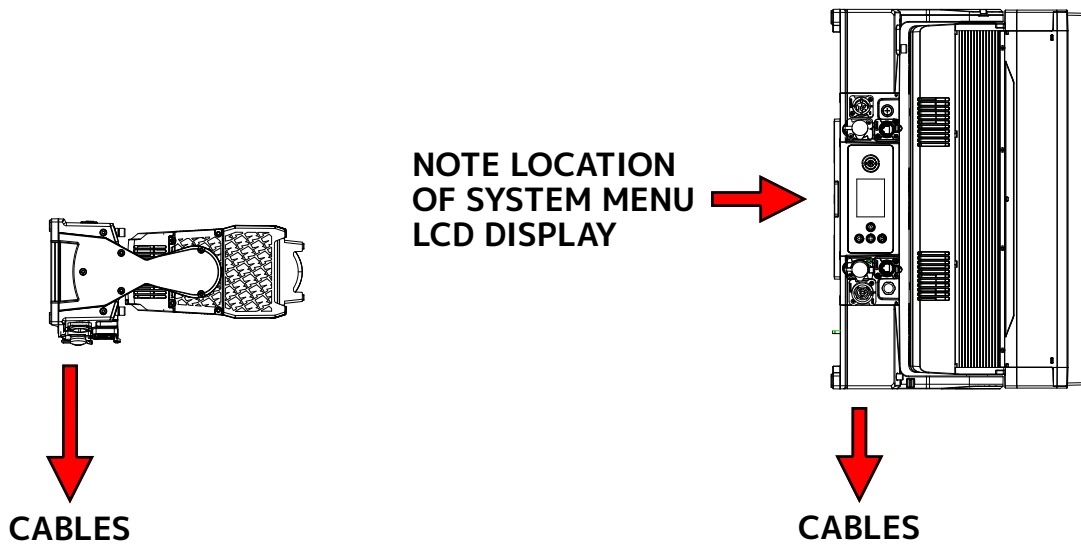

# INSTALLATION GUIDELINES

## POTENTIAL INTERNAL FIXTURE DAMAGE FROM EXTERNAL SOURCES OF LIGHT BEAMS

External sources of light beams from direct sunlight, lighting moving head fixtures, and lasers, which are focused directly towards the exterior housing and/or penetrate the front lens opening of ELATION lighting fixtures, can cause severe internal damage including burning to optics, dichroic color filters, glass and metal gobos, prisms, animation wheels, frost filters, iris, shutters, motors, belts, wiring, discharge lamps, and LEDs.

This issue is not specific only to ELATION lighting fixtures, it is a common issue with lighting fixtures from all manufacturers. Although there is no true way to fully prevent this issue from happening, the guidelines below can prevent any potential damage from occurring if followed. Contact ELATION Service for more details.

**DO NOT EXPOSE THE FIXTURE AND/OR FRONT LENS OPENING TO LIGHT BEAMS FROM DIRECT SUNLIGHT, OTHER LIGHTING MOVING HEAD FIXTURES, AND LASERS WHILE UNPACKING, INSTALLATION, USE, AND EXTENDED IDLE TIMES OUTDOORS. DO NOT FOCUS A LIGHT BEAM FROM ONE LIGHTING FIXTURE DIRECTLY TOWARDS ANOTHER.**

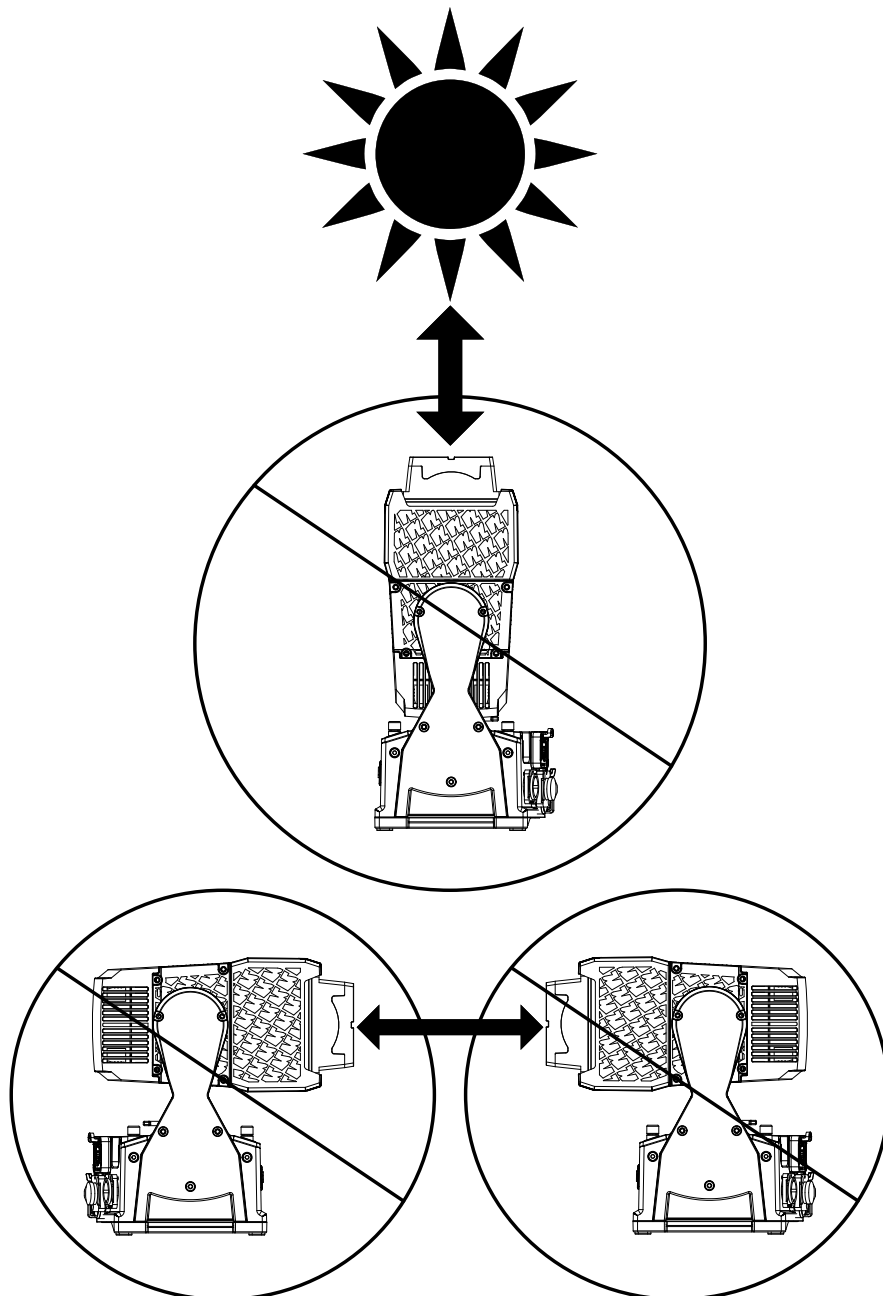

# ACCESSORY INSTALLATION - FRONT LOUVER

Each Front Louver is secured to the Rebel Line 8 using six Phillips-head screws. Note their locations, indicated below by the red circles.

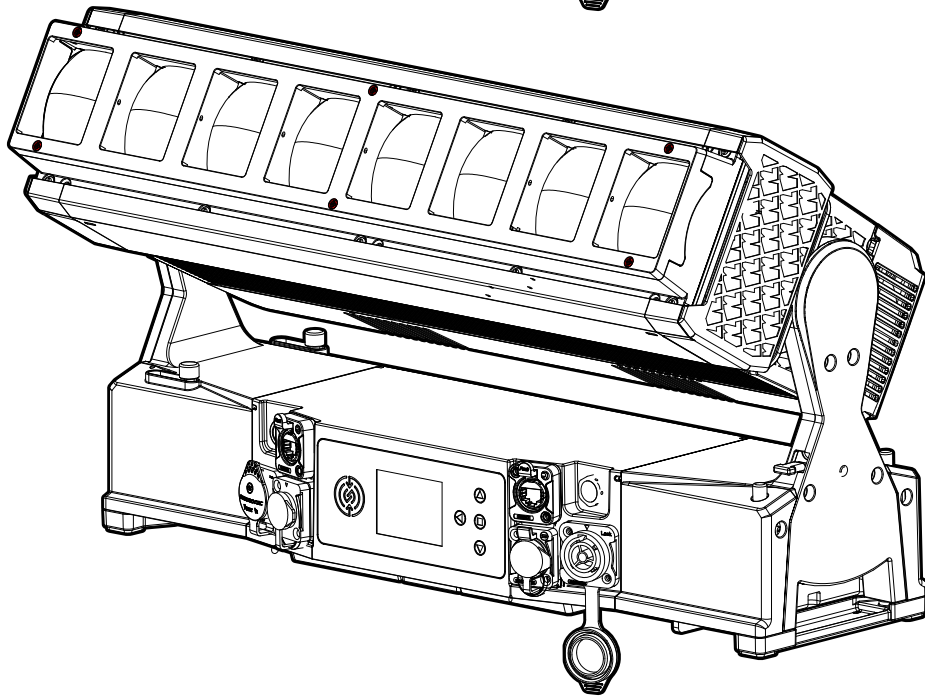
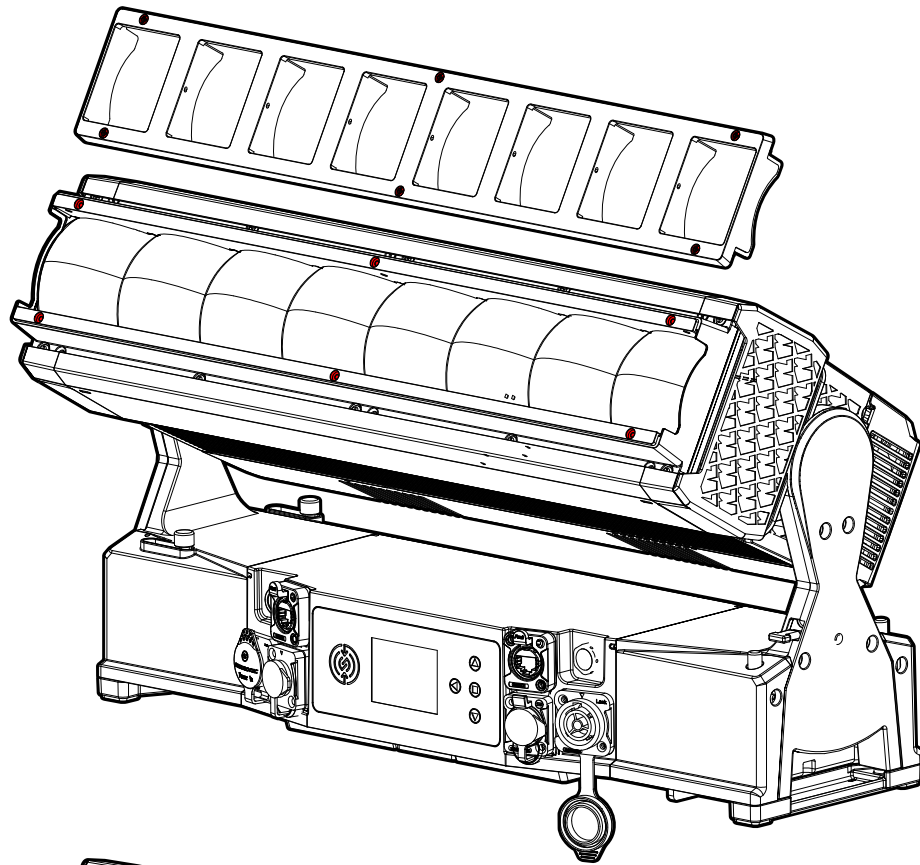

# ACCESSORY INSTALLATION - DIFFUSER FILTER

Each Diffuser Filter is secured to the Rebel Line 8 using six Phillips-head screws. Note their locations, indicated below by the red circles.

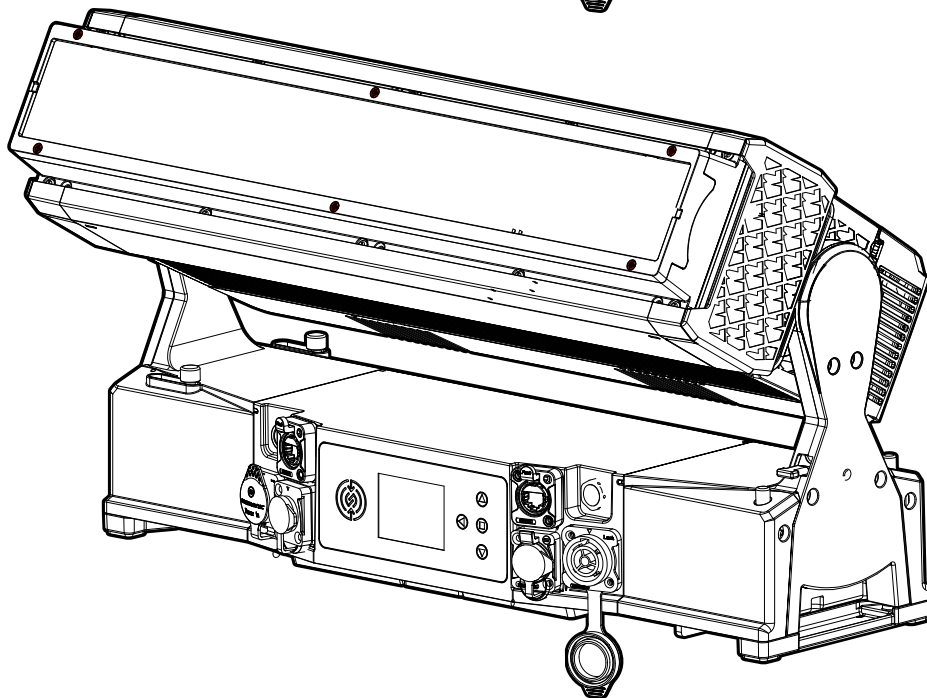
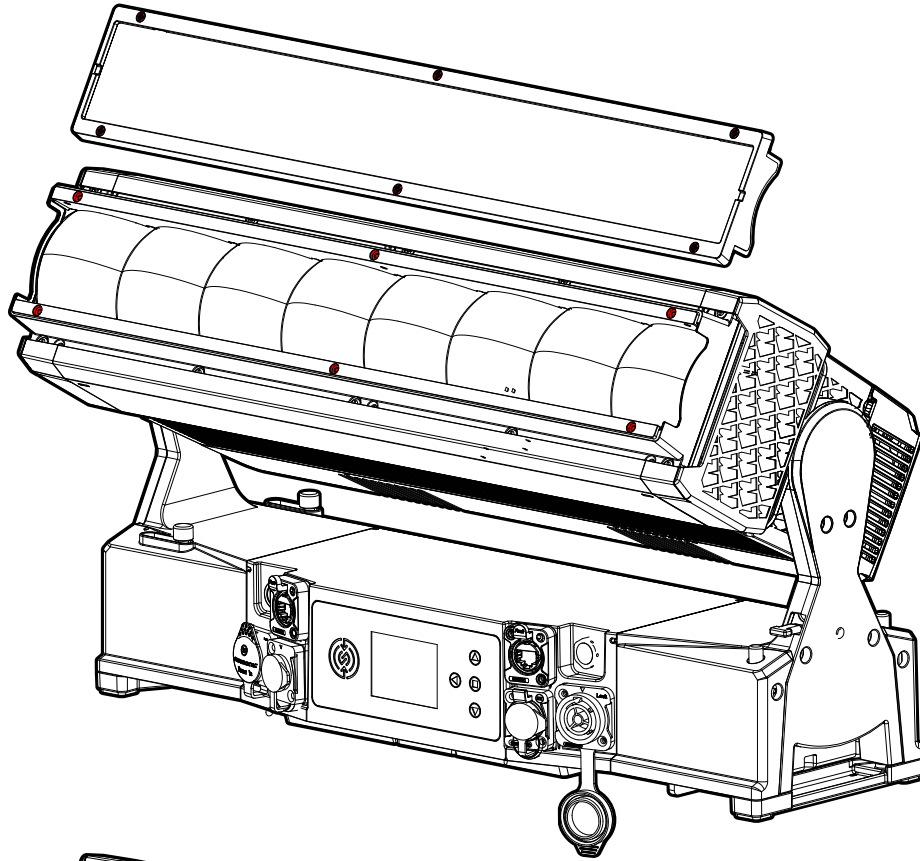

# ARIA SETUP AND GUIDELINES

## 2GHZ Versus Sub-Gig (GHz) Frequencies:

Sub-GHz frequencies provide superior reliability and range compared to higher frequencies, making them perfect for consistent communication across vast distances or in difficult conditions. Devices operating in the sub-GHz range, which refers to frequencies below 1 GHz, can transmit signals over significant distances and can penetrate physical barriers such as walls and buildings more effectively. Additionally, these frequencies experience less interference compared to those in the heavily congested 2.4-GHz band, which is commonly used by wireless devices.

In the United States, the 900 MHz band is a versatile frequency range that is utilized by various services, with the FCC overseeing its allocation and regulation.

In the European Union, the 868 MHz frequency is designated by ETSI as the Sub-Gig frequency.

In summary, if an application demands high data rates and more bandwidth in urban or densely populated areas where interference management is feasible, the 2.4 GHz frequency is a suitable choice. On the other hand, for applications requiring long-range communication and better obstacle penetration, particularly in rural or industrial settings with fewer regulatory constraints, a sub-GHz frequency (<1 GHz) is a better option.

## Installation Recommendations:

With the many factors that affect and/or interrupt a wireless signal such as walls, glass, metal, objects, and people, it is highly recommended to:

- Install devices a minimum of 9.8 ft. (3m) above audiences and/or ground level where practical.
- Adjust the wireless antenna in a vertical upright position
- Position devices in direct line of sight of the controlling Aria device

Careful planning and testing of the selected installation location is critical to ensure optimum and reliable wireless operation.

**9.8 ft (3m)  
Above Ground**

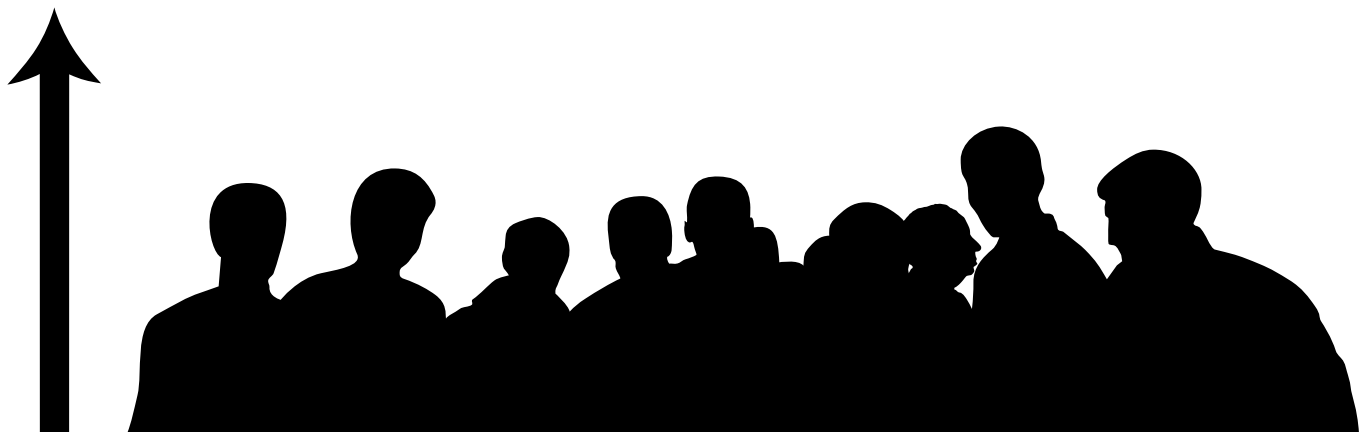

# ARIA SETUP AND GUIDELINES

## GENERAL INFORMATION

The Aria Bluetooth app has the ability to connect wirelessly to any device that has Aria wireless DMX installed and has Bluetooth enabled.

Before installing the fixture in a remote location, double check that the fixture's main power is switched on, and that the Bluetooth function has been enabled in the fixture's system menu. Certain fixtures may have Bluetooth disabled by default. If this function is disabled, then the fixture cannot be configured remotely using the Aria app, and will have to be configured directly from the fixture's control screen.

Additionally, the user should consider setting the fixture's No DMX setting to "Hold Last". This will allow the fixture to continue running using the current settings, even if the Aria app device moves out of range, the app is closed, or the signal is otherwise interrupted, minimizing disruption in the operation of the fixtures.

## LEGACY DEVICES

Please note that legacy connected devices, such as those using Wifly, E-Fly, or Magfly, are not compatible with this app. For such legacy devices, the use of a bridge is recommended, as the bridge can communicate with these devices via its SM220 protocol.

The Aria X2 BLE app is currently available from the Apple app store.

## FIXTURE IDENTIFICATION

Aria compatible devices can be identified and connected via the Fixtures tab in the app. This tab displays a field of twenty-four buttons that can be assigned to Aria compatible devices that are within range, and the buttons will automatically be assigned to devices in the order in which they are discovered. If more than twenty-four units are within range, it may be necessary to use the filter feature to search for the desired fixture. Button location can be edited by selecting the configuration key, then the user can drag and drop the buttons to the desired location and hit save to keep changes. Once a device is known to the app, it can also be assigned to a particular button. From that point forward, the assigned device will always be assigned to that button location.

**IMPORTANT NOTE:** For version 0.65 or higher, a shared system password is required to connect to any device.

Unlike wireless DMX, Bluetooth is a connect first protocol. To connect to a device or fixture, tap the assigned button in the **Fixtures** tab. If the connection is successful, a green frame will appear around the button, indicating that the app was able to retrieve the current channel values from the fixture. The app must be connected to a fixture in order to use its channel controls or view and change settings. Please note that not all Aria devices have channel controls.

Additionally, each fixture can only be connected to one device with the app at any given time. Once a fixture is connected to the app installed on one device, any other devices will be blocked from connecting. As a result, when setting up a new fixture for the first time, best practice is to have only a single user with the app open within range, in order to ensure that the fixture pairs to the intended user's device.

# ARIA SETUP AND GUIDELINES

The second table section shows all Aria devices detected in range. A checkmark indicates the device is currently assigned to a button. If more than 24 devices are within range, the user may remove or add devices to the buttons list by tapping a row to check or uncheck a device. If all buttons are full, it will be necessary to uncheck a device before adding another.

**Filter:** The user can filter which Aria devices get button assignments by tapping “filter” at the top of the view. A popup will appear where the user can enter text to filter devices by username, model name, or manufacturer. **Please note that these searches are case sensitive.**

**Note:** If a device shows an asterisk (\*) it means that there is no fixture profile currently available, and therefore there will be limited support available for that device. The user will still be able to connect and adjust channels if the device supports that feature, but the user will not be able to view how many channels the device has or the channel names.

## SECURITY

Each fixture must have a password saved to be secure. When a new fixture is installed for the first time, its password will automatically be set to the app’s system password on first connection. Once the password has been entered, the user will need to exit out to the main page containing the fixture buttons, then de-select and re-select the fixture to lock in the password. From that point forward only, controlling devices that use the correct password can connect to this fixture. **This security is now required by law in most jurisdictions.**

The app will detect any Aria capable fixture within range, even if the app does not have the password to that fixture and therefore cannot access that fixture. If that fixture is selected in the app, the green frame will momentarily appear around that fixture’s button, but then disappear. This indicates that the fixture is visible but inaccessible.

# SYSTEM MENU

The fixture includes an easy to navigate system menu. The control panel (see image below) located on the front of the fixture, provides access to the main system menu and is where all necessary system adjustments are made to the fixture. During normal operation, pressing **ENTER** button once will access the fixture's main menu. Once in the main menu you can navigate through the different functions and access the submenus with the **UP** and **DOWN** buttons. Once you reach a field that requires adjusting, press the **ENTER** button to activate that field and use the **UP** and **DOWN** buttons to adjust the field. Pressing the **ENTER** button once more will confirm your setting. You may exit the main menu at any time without making any adjustments by pressing the **ENTER** button.

## Screen Lock:

By default, the **Screen Lock** is set to **On**. Press **UP, DOWN, UP, DOWN, ENTER** to unlock display screen lock.

## Display Shortcuts:

**Power Off:** Long press the **ENTER** button for 3s, activate battery mode

**Power On:** Long press the **ENTER** button for 10s, unlock display, show 10s countdown.

Long press the **UP** button and the **DOWN** button for 3s, disable Pan Tilt.

Long press the **BACK** button and the **ENTER** button for 5s, countdown 10 sec or Reset to Default.

**NOTE:** To access the LCD Menu Control Display via the internal battery, press and hold the **MODE/ESC** button for 10 seconds. The LCD Menu Control Display will shut **OFF** automatically about 1 minute from the last button press.

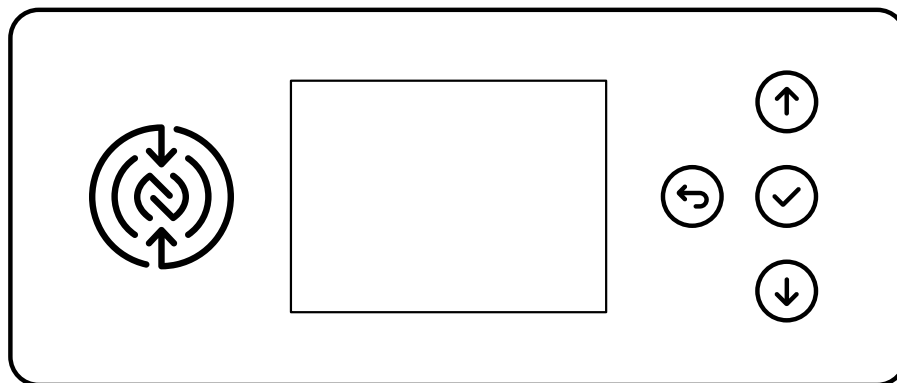

**IMPORTANT: THIS FIXTURE IS EQUIPED WITH ARIA X2. ARIA'S WIRELESS FEATURES HAE BEEN SET TO OFF BY DEFAULT. ACTIVATE ARIA X2 AND BLUETOOTH IN THE SYSTEMS MENU TO TAKE ADVANTAGE OF ITS WIRELESS FEATURE SET FOR WIRELESS CONNECTIVITY AND OVER THE AIR SOFTWARE UPDATES.**



**AN ELATION C-LOADER CAN BE USED TO UPDATE THE FIXTURE TO THE LATEST SOFTWARE. SEE PAGE 41 FOR INSTRUCTIONS. TO ORDER THIS DEVICE, PLEASE CONTACT ELATION SUPPORT FOR FURTHER DETAILS.**

**ELATION SERVICE USA - Monday - Friday 8:00am to 4:30pm PST  
323-582-3322 | support@elationlighting.com**

**ELATION SERVICE EUROPE - Monday - Friday 08:30 to 17:00 CET  
+31 45 546 85 63 | support@elationlighting.eu**

# SYSTEM MENU

MAIN MENU	OPTIONS / VALUES (Default Settings in <b>BOLD</b> )		
<b>DMX</b>	DMX Address	<b>001</b> - 512	
	DMX Mode	Standard, <b>Extended</b> , Pixels	
	No DMX Status	<b>Hold Last</b> , Fade to Black, Sun Protection	
		Hibernation	Off, 1-99M (Default = <b>15 Min</b> )
	Protocol	Select Signal	<b>DMX</b> , Art-Net, sACN, Aria In-DMX Out, DMX In - Aria Out
		Universe	1
		DHCP	<b>Off</b> /On
		IP Address	2.x.x.x
		Subnet Mask	255.0.0.0
		Ethernet DMX Out	<b>Off</b> /On
	Aria	Enable Aria	<b>Off</b> / On
		Frequency	<b>2.4Ghz</b> / Sub Gig- US / Sub Gig- EU
		2.4Ghz Chan	<b>00</b> -15
		Sub Gig Chan	<b>00</b> -09
Enable Mesh		<b>Off</b> / On	
Enable Bluetooth		<b>Off</b> / On	
<b>Control</b>	Manual Control	Dimmer 0% - <b>100%</b>	
		Tilt, ...	
	Reset	All, Movement, Color Mix, Zoom	
Self Test	All, Dimmer, Movement, Color Mix, Zoom		
<b>Settings</b>	Fan Mode	Mute, Studio, Low, High, <b>Auto</b>	
	Movement	Tilt Invert	<b>Off</b> /On
		Tilt Speed	Smooth/ <b>Fast</b>
		Tilt Feedback	Off/ <b>On</b>
		Zoom Speed	Smooth/ <b>Fast</b>
	Dimmer Curve	Linear, Squre, Square Inverse, <b>S-Curve</b>	
	Dimmer Mode	Standard, Stage, TV, Architectural, Theatre, Stage 2	
		Dim Speed	0s - 10s
	Dim to Warm	On / <b>Off</b>	
	Pixel Flip	On / <b>Off</b>	
	LED Refresh Rate	900Hz - 1500Hz ( <b>1200Hz</b> ), 2500Hz, 4000Hz, 5000Hz, 6000Hz, 10KHz, 15KHz, 20KHz, 25KHz	
	LED Power Limit	50%, 60%, 70%, 80%, 90%, <b>100%</b>	
	Display	Screen Delay	10s - 5min (Default = <b>1 min</b> )
Screen Lock		<b>Off</b> , 10s - 5 min, <b>Key Lock</b>	
Auto Rotate		Off, On	
Reset Defaults	Yes / <b>No</b>		
<b>Information</b>	Time	Current Time, Total Run Time, Last Run Time, LED Time	
	Temperature	Head, Base, LED	
	Humidity	Head, Base	
	Fan	Fan xx, ..., Tilt, ...	
	DMX Values	Pan, Tilt, ...	
	Product IDs	RDM UID	
	Error Logs	Fixture Errors	
	Software Version	Vx.x	
<b>Service</b> (Passcode <b>50</b> )	Calibration	Dimmer, Tilt, ...	
	Reset Last Run	Yes / No	
	Reset Error Logs	Yes / No	

## Display Shortcuts

<b>Power On</b>	Up, Down, Up, Down, Enter	Unlock display, show 10s countdown
	Up+Down (3s)	Disable Pan Tilt
	Back+Enter (10s)	Countown 10 sec
Reset Default (no/yes)		

# SUN PROTECTION MODE

The fixture incorporates an automatic protection from harmful sunlight, which can damage a fixture's internal components from extended exposure. Fixtures use an internal sensor to determine their physical orientation, then reorient the fixture towards the ground to prevent sunlight from entering the lens.

This automatic feature only works when the fixture is powered. If the fixture is unpowered during setup, it is necessary to manually reorient the lenses away from the sun, and aim them towards the ground. Even a few minutes of sun exposure can cause damage inside the fixture.

The Sun Protection setting is accessed via the "No DMX Status" menu.

The automatic sun protection positioning is activated under the following conditions:

1. Power on without DMX signal: the fixture always starts in sun protection mode.
2. No DMX Status "Sun Protection": the fixture enters sun protection mode after approximately 3 minutes.
3. Remote DMX control: the sun protection position can be **temporarily** activated from the lighting console without the need to create a custom position preset. The fixture senses the correct ground orientation. This means that fixtures already facing the ground may not move their heads.

Hold "Sun Protect Position" for 3s to set the fixture to the sun protection position.

Sun protection status displays as "**Sun Protection: Active**".

The sun protection position deactivates under the following conditions:

1. Connect DMX signal.
2. Remote DMX control: Hold "Sun Protection Off" for 3s.

To avoid harsh or jarring movements, the sun protection position always uses a 5-second fade time when it is activated or deactivated.

# HIBERNATION MODE

To reduce wear on the fixture and its components, this mode disables motors and most electronics. Set the hibernation mode countdown time in the Display Menu: "Status Settings / Personality / Hibernation". Hibernation can be fully disabled.

The hibernation mode activates under the following conditions:

1. Loss of DMX: the fixture enters hibernation after the timeout expires. Default is 15 minutes.
2. Remote DMX control: Hold "Hibernate Fixture" for 3s

The hibernation mode deactivates under the following conditions:

1. Connect DMX Signal
2. Remote DMX control: Hold "Hibernate Off" for 3s

The fixture will perform a full calibration cycle, then assume the current DMX status.

Please note that the Hibernation does not change the PT position of the fixtures, allowing the user to set the desired position and then issue the Hibernate command.

To ensure the fixture is protected from harmful sunrays it is recommended to either leave the "No DMX Status" in "Sun Protection" (so the fixture is already in the correct position after 3 minutes of DMX loss) or set the fixture to a safe Tilt position manually first before hibernation.

**Burn and heat damage to the fixture's interior components due to external light sources (sun or other fixtures shining into the lens) is never covered under the manufacturers warranty.**

# FAN MODES AND LOW NOISE OPERATION

This fixture is a high-performance fixture suited for many applications. For noise critical environments like Theater, Opera or Orchestra Halls, it offers various operation modes to remove any distraction for the audience and performers. Modes can be changed remotely via the DMX control channel, allowing the fixture to offer high output or quiet operation at a moment's notice. All modes smoothly transition over a brief period, preventing unwanted attraction to the fixture.

## Fan Modes

**Auto** – The default AUTO mode ensures optimal performance of the fixture. Fans only run at the speeds needed to keep the LED engine within a safe temperature range. They will turn off if possible, for example when the fixture is dimmed to a low intensity. Fans sense the ambient and fixture temperature, and will at all times try to keep noise levels at a minimum. The fixture output will only reduce when the LED engine cannot be cooled down to its safe operating range due to high ambient temperature. **Auto is the recommend mode for daily operation of the Rebel Line 8.**

**Low** – In this mode the fixture reduces fan speeds throughout for a lower noise profile of the fixture. This mode should be sufficient for most uses where lower noise is required. The fixture output is reduced to about 80%.

**High** – This mode is only required in very high ambient temperatures when automatic fan speed adjustments are not desired. High Fan Speed will cool the fixture most efficiently. This mode will increase wear on the fans and should only be utilized in exceptional circumstances. Fans will always run, even if the fixture is dimmed. Fixture output is kept at 100% unless the LED engine temperature is too high, at which point the fixture will reduce power carefully to ensure safe operation.

## Low Noise Modes

For very critical situations, the fixture offers two additional low noise modes for silent operation. The fixture output will be reduced, but as the fixture has such an extremely high luminous flux, it still offers outstanding performance.

**Studio** – This mode reduces the fixture output to approximately 50%.

**Mute** – Running the fixture in MUTE mode reduces the fixture to about 25% output.

# DIMMER MODE

DIMMER

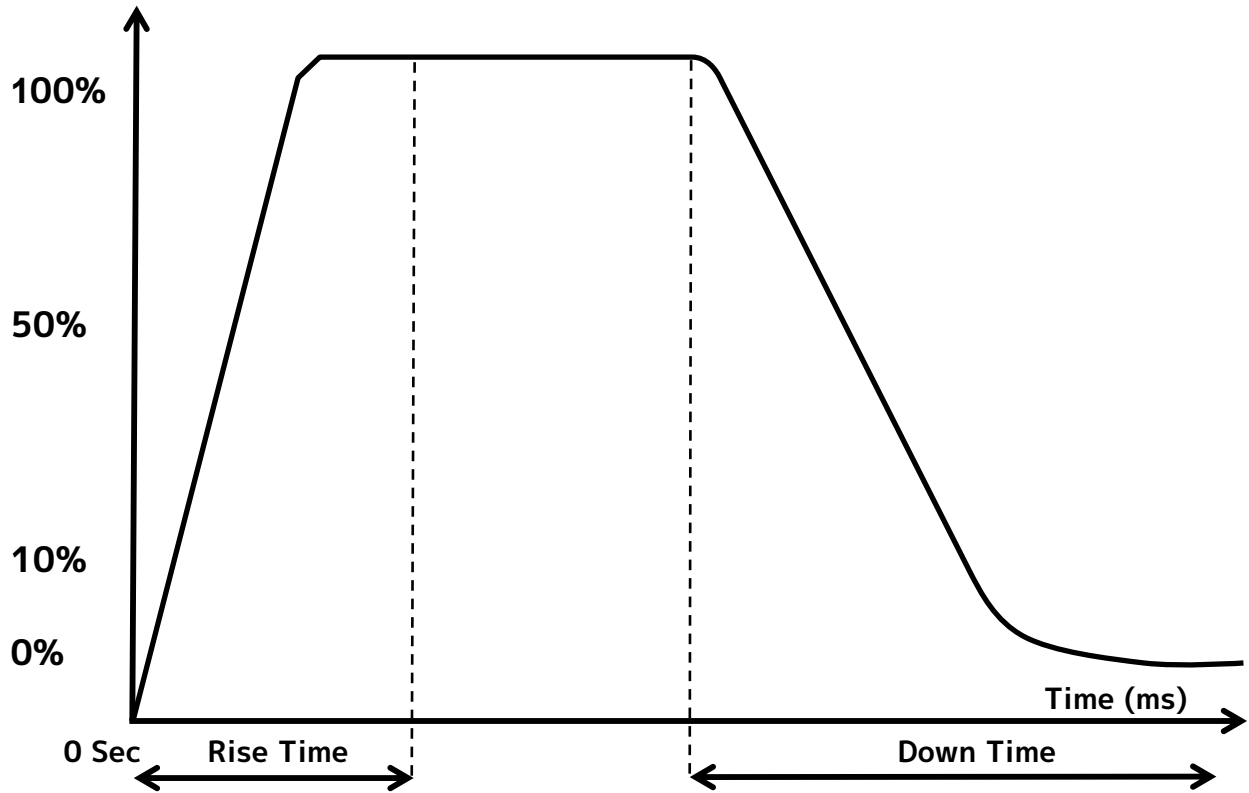

Dimming Curve Ramp Effect	0 sec Fade Time		1 sec Fade Time	
	Rise Time (ms)	Down Time (ms)	Rise Time (ms)	Down Time (ms)
Standard (default)	0	0	0	0
Stage	780	1100	1540	1660
TV	1180	1520	1860	1940
Architectural	1380	1730	2040	2120
Theatre	1580	1940	2230	2280
Stage 2	0	1100	0	1660

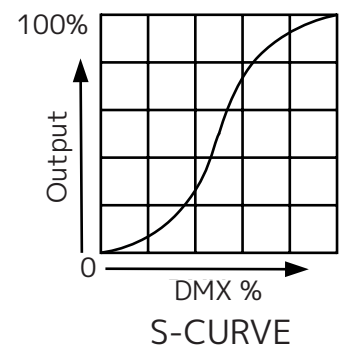
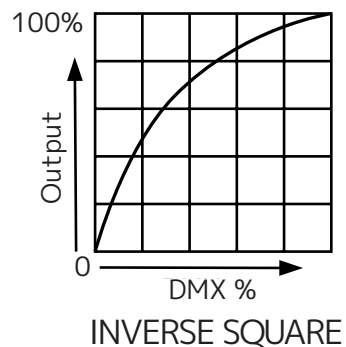
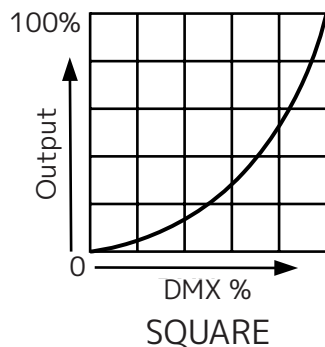
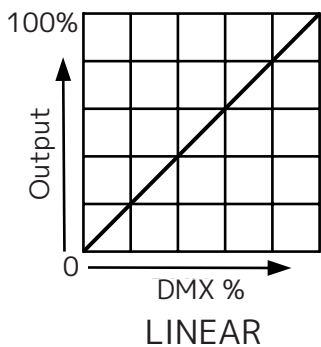

# PATCHING AND FX PROGRAMMING GUIDE

The Rebel Line 8 is a versatile fixture that combines two unique LED arrays into one chassis. The DMX layout is designed to offer a variety of options for controlling the fixture efficiently, allowing control of many FX with very few channels, or providing full access of all elements for external pixel mappers. The FX system of the Rebel Line 8 allows many different combinations by changing the curves, offsets, and speed parameters. The RGLB and SparkX LED systems are separate, and by adjusting color, dimming, and strobe channels, there are endless creative designs possible. The main fixture contains 8x 60W RGLB cells, while the SparkX LED fixture contains 16x 10W CW LEDs. For ease of use, the DMX layout is arranged to allow the lighting console to separate the fixture into multiple segments, or parts. It is important to arrange the fixture into the required parts as outlined in the DMX table. For simpler programming, the fixture also offers reduced channel modes. However, for easy recall of interesting pixel animations, the fixture contains independent FX systems for Main and SparkX FX. The LINE 8 mode splits the fixture into two independent Rebel Line 8 bars on one base.

## Fixture Parts

To control the fixture, a console fixture profile must combine parameters into the correct parts, otherwise, programming of the two layers is very difficult. Please use the part names shown in the DMX table.

<b>Main</b>	RGLB Dimmer, Strobe, Tilt, Main FX Controls, FX Sync#
<b>Pixels</b>	Red, Green, Blue, Lime per cell #
<b>SparkX</b>	SparkX Dimmer, Strobe, SparkX FX Controls #

The number of parts depends on the selected DMX mode of the fixture. Depending on console type and application, it may be useful to have all parts as sub-fixtures, or create completely separate fixture types for Main and SparkX with their own smaller subset of fixture parts.

# PATCHING AND FX PROGRAMMING GUIDE

## FX Concept

Selection and control of integrated FX on the Rebel Line 8 are found in the Main and SparkX Parts. All FX are available even in the smallest DMX control mode.

	<b>RGBW FX (see table)</b>
0-255	FX Selection 1-255
	<b>RGBW FX Speed</b>
0-126	Rev Fast → Slow
127-128	Stop
129-255	Slow → Fast
	<b>SparkX FX (see table)</b>
0-255	FX Selection 1-255
	<b>SparkX FX Speed</b>
0-126	Rev Fast → Slow
127-128	Stop
129-255	Slow → Fast

FX for RGBL and SparkX contain a selection channel to recall the desired pattern. The pattern direction and speed is then adjusted using the associated Speed channel. FX can run forward / backward and can also be frozen at any time by using "Stop".

The FX table shows the available patterns which are grouped for easier browsing. The first 10 DMX steps of the FX channel are used to change the type of curve for smooth or stepped FX. Once a curve is selected its used for all FX recalled afterwards. When programming cues for fixtures the user must ensure to change the curve first before selecting the pattern. The fixture defaults to the Sinewave pattern after every power cycle.

In addition to the FX direction and speed, the Sync channel allows offsetting or randomizing the fixtures or FX steps.

	<b>FX Offset</b>
0	Idle
1	Fixture Offset 10 Degree
2	Fixture Offset 20 Degree
3-34	Fixture Offset...
35	Fixture Offset 350 Degree
36	Synchronized
37-49	Random Fixture Offset
50-59	Random Pixel Order
60-69	Random Steps
70-79	Idle
	<b>Effect Fade</b>
80-89	Sinewave- Cross
90-99	Sinewave- Full
100-109	Sawtooth- Cross
110-119	Sawtooth- Full
120-129	Ramp Up
130-139	Ramp Down
140-149	Steps
150-255	Idle

# PATCHING AND FX PROGRAMMING GUIDE

A full FX cycle is 360-degrees and the fixture allows offsets in 10 degree increments. Offsetting a fixture by 180 would mean it is exactly halfway ahead through the FX cycle. Through individual offsets or utilizing lighting consoles fan functions the fixture allows a variety of spreads for impactful FX.

Three randomization options are provided:

**Random Fixture Offset:** Every fixture randomly selects any of the 36 offset points. It will then use this until the offset is changed or random offset is selected again.

**Random Pixel Order:** The actual FX steps are randomized. This shuffling of the fixture order is done once, the fixture will use this shuffled order across all FX until changed.

**Random Steps:** Every step is randomly chosen every time, giving the most random looks possible.

To reshuffle the randomization set the channel to Idle, then reselect the desired random option.

The FX system of the Rebel Line 8 allows many different combinations by changing the curves, offsets, and speed parameters. The RGBL and SparkX systems are separate, and by adjusting color, dimming, and strobe channels, there are endless creative designs possible.

# DMX TRAITS - STANDARD

Mode/Channel			Value	Function	Snap	Default
Standard	Extended	Pixels				
1	1	1	0-255	<b>Tilt</b> Left → Right		
2	2	2	0-255	<b>Tilt Fine</b> Fine Position		
3	3		0-255	<b>Red</b> 0 → 100%		
	4		0-255	<b>Red Fine</b> Fine Saturation		
4	5		0-255	<b>Green</b> 0 → 100%		
	6		0-255	<b>Green Fine</b> Fine Saturation		
5	7		0-255	<b>Blue</b> 0 → 100%		
	8		0-255	<b>Blue Fine</b> Fine Saturation		
6	9		0-255	<b>Lime</b> 0 → 100%		
	10		0-255	<b>Lime Fine</b> Fine Saturation		
7	11	3	0-23 24-255	<b>Variable CCT</b> Open (6000K) 2400K → 8500K (see table)		
	12	4	0-255	<b>Variable CCT Fine</b>		
8	13	5	0 1-179 180-201 202-207 208-229 230-234 235-239 240-244 245-249	<b>Color</b> Open Virtual Swatch Book (See Sheet) <b>Scroll</b> Clockwise Fast → Slow Stop Counter-clockwise Slow → Fast Open <b>Random Slots</b> Fast Medium Slow Open	X	
9	14	6	0-255	<b>Zoom</b> Narrow → Wide		
	15	7	0-255	<b>Zoom Fine</b> Fine Adjustment		

# DMX TRAITS - STANDARD

Mode/Channel			Value	Function	Snap	Default
Standard	Extended	Pixels				
10	16	8		<b>Strobe</b>	X	
			0-31	Closed		
			32-63	Open		
			64-95	Strobe effect slow to fast		
			96-127	Open		
			128-159	Pulse Effect		
			160-191	Open		
			192-223	Random Slow → Fast		
224-255	Open					
11	17	9	0-255	<b>Dimmer</b> 0 → 100%		
12	18	10	0-255	<b>Dimmer Fine</b> Fine Adjustment		
	19	11		<b>Dimmer Modes</b>	R G B L P i x e l s	X
			0-20	Standard		
			21-40	Stage		
			41-60	TV		
			61-80	Architectural		
			81-100	Theatre		
			101-120	Stage 2		
				<b>Dimmer Time</b>		
			121	0s		
			122	0.1s		
			123	0.2s		
			124	0.3s		
			125	0.4s		
			126	0.5s		
			127	0.6s		
			128	0.7s		
			129	0.8s		
			130	0.9s		
			131	1.0s		
			132	1.5s		
			133	2.0s		
			134	3.0s		
			135	4.0s		
			136	5.0s		
			137	6.0s		
			138	7.0s		
			139	8.0s		
			140	9.0s		
			141	10s		
				<b>Dim to Warm</b>		
150-154	DTW On					
155-159	DTW Off					
160-255	Idle					

# DMX TRAITS - STANDARD

Mode/Channel			Value	Function	Snap	Default
Standard	Extended	Pixels				
	20	12		<b>Tilt Speed</b>	X	
			0-225	Max → Min Speed		
			226-235	Blackout by movement		
			236-245	Blackout by wheel changes		
			246-255	No function		
13	21	13		<b>Control</b>	X	
			0-10	Idle		
				<b>Fan Mode</b>		
			50-59	Low		
			60-69	High		
			70-79	Auto		
				<b>Reset</b>		
			80-84	All		
			85-87	Tilt		
			88-90	Zoom		
			97-99	Idle		
				<b>Refresh Rate (Hz)</b>		
			100	900		
			101	910		
			102	920		
			103	930		
			104	940		
			105	950		
			106	960		
			107	970		
			108	980		
			109	990		
			110	1000		
			111	1010		
			112	1020		
			113	1030		
			114	1040		
			115	1050		
			116	1060		
			117	1070		
			118	1080		
			119	1090		
120	1100					
121	1110					
122	1120					
123	1130					
124	1140					
125	1150					
126	1160					
127	1170					
128	1180					
129	1190					

# DMX TRAITS - STANDARD

Mode/Channel			Value	Function	Snap	Default
Standard	Extended	Pixels				
13	21	13	130	<b>1200</b>	X	
			131	1210		
			132	1220		
			133	1230		
			134	1240		
			135	1250		
			136	1260		
			137	1270		
			138	1280		
			139	1290		
			140	1300		
			141	1310		
			142	1320		
			143	1330		
			144	1340		
			145	1350		
			146	1360		
			147	1370		
			148	1380		
			149	1390		
			150	1400		
			151	1410		
			152	1420		
			153	1430		
			154	1440		
			155	1450		
			156	1460		
			157	1470		
			158	1480		
			159	1490		
			160	1500		
			161	2500		
162	4000					
163	5000					
164	6000					
165	10000					
166	15000					
167	20000					
168	25000					
169-174	Idle					
	<b>Pixel Flip</b>					
175-179	Default Pixel order					
180-184	Flip Pixel Order					
185-200	Idle					
	<b>Dimmer Curves</b>					
201-210	Linear					
211-220	Square					
221-230	Inverse Square					
231-240	S-Curve (Default)					
241-255	Idle					

# DMX TRAITS - STANDARD

Mode/Channel			Value	Function	Snap	Default
Standard	Extended	Pixels				
14	22	14		<b>ColorFX Selection</b>	X	0
			0	Idle		
			1-255	FX 1 → 255 (see table)		
15	23	15		<b>Color FX Speed</b>		0
			0-126	Slow → Fast		
			127-128	Stop		
			129-255	Rev Fast → Slow		
16	24	16		<b>SparkX FX Selection</b>	X	0
			0	Idle		
			1-255	FX 1 → 255 (see table)		
17	25	27		<b>SparkX FX Speed</b>		0
			0-126	Slow → Fast		
			127-128	Stop		
			129-255	Rev Fast → Slow		
18	26	18		<b>FX Zoning</b>		
			0-255	Reserved		
19	27	19		<b>FX Offset</b>	X	0
			0	Idle		
			1	Fixture Offset 10 Degrees		
			2	Fixture Offset 20 Degrees		
			3-34	Fixture Offset...		
			35	Fixture Offset 350 Degrees		
			36	Synchronized		
			37-49	Random Fixture Offset		
			50-59	Random Pixel Order		
			60-69	Random Steps		
			70-79	Idle		
				<b>Effect Fade</b>		
			80-89	Sinewave- Cross		
			90-99	Sinewave- Full		
			100-109	Sawtooth- Cross		
			110-119	Sawtooth- Full		
			120-129	Ramp Up		
			130-139	Ramp Down		
140-149	Steps					
150-255	Idle					

# DMX TRAITS - EXTENDED

Mode/Channel			Value	Function	Snap	Default
Standard	Extended	Pixels				
		20	0-255	<b>Red 1</b> 0 → 100%		
		21	0-255	<b>Green 1</b> 0 → 100%		
		22	0-255	<b>Blue 1</b> 0 → 100%		
		23	0-255	<b>Lime 1</b> 0 → 100%		
		24	0-255	<b>Red 2</b> 0 → 100%		
		25	0-255	<b>Green 2</b> 0 → 100%		
		26	0-255	<b>Blue 2</b> 0 → 100%		
		27	0-255	<b>Lime 2</b> 0 → 100%		
		28	0-255	<b>Red 3</b> 0 → 100%		
		29	0-255	<b>Green 3</b> 0 → 100%		
		30	0-255	<b>Blue 3</b> 0 → 100%		
		31	0-255	<b>Lime 3</b> 0 → 100%		
		32	0-255	<b>Red 4</b> 0 → 100%		
		33	0-255	<b>Green 4</b> 0 → 100%		
		34	0-255	<b>Blue 4</b> 0 → 100%		
		35	0-255	<b>Lime 4</b> 0 → 100%		
		36	0-255	<b>Red 5</b> 0 → 100%		
		37	0-255	<b>Green 5</b> 0 → 100%		
		38	0-255	<b>Blue 5</b> 0 → 100%		
		39	0-255	<b>Lime 5</b> 0 → 100%		
		40	0-255	<b>Red 6</b> 0 → 100%		
		41	0-255	<b>Green 6</b> 0 → 100%		
		42	0-255	<b>Blue 6</b> 0 → 100%		
		43	0-255	<b>Lime 6</b> 0 → 100%		

# DMX TRAITS - EXTENDED

Mode/Channel			Value	Function	Snap	Default
Standard	Extended	Pixels				
		44	0-255	<b>Red 7</b> 0 → 100%		
		45	0-255	<b>Green 7</b> 0 → 100%		
		46	0-255	<b>Blue 7</b> 0 → 100%		
		47	0-255	<b>Lime 7</b> 0 → 100%		
		48	0-255	<b>Red 8</b> 0 → 100%		
		49	0-255	<b>Green 8</b> 0 → 100%		
		50	0-255	<b>Blue 8</b> 0 → 100%		
		51	0-255	<b>Lime 8</b> 0 → 100%		

# DMX TRAITS - PIXELS

Mode/Channel			Value	Function	Snap	Default
Standard	Extended	Pixels				
20	28	52		<b>Strobe</b>		
			0-31	Closed		
			32-63	Open		
			64-95	Strobe effect slow to fast		
			96-127	Open		
			128-159	Pulse Effect		
			160-191	Open		
			192-223	Random Slow → Fast		
		224-255	Open			
21	29	53	0-255	<b>Dimmer</b> 0 → 100%		
22	30	54	0-255	<b>Dimmer Fine</b>		
		55	0-255	<b>Dimmer 1</b> 0 → 100%		
		56	0-255	<b>Dimmer 2</b> 0 → 100%		
		57	0-255	<b>Dimmer 3</b> 0 → 100%		
...						
		70	0-255	<b>Dimmer 16</b> 0 → 100%		

# PIXEL GROUPING

## 8 PIXEL GROUPING

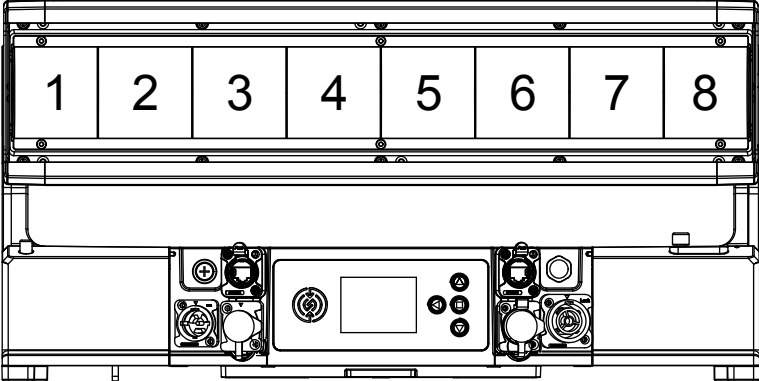

# COLOR FX TABLE

Features subject to change without notice				
TYPE	SLOT	DMX	NAME	NOTES/STEPS
Intensity	1	1	Single	1,2,3,4,5,6,7,8,9,10,11,12
	2	2	Single Bounce	1,2,3,4,5,6,7,8,9,10,11,12,11,10,9,8,7,6,5,4,3,2
	3	3	2 Pixels	Any two random pixels per step
	4	4	3 Pixels	Any 3 random pixels per step
	5	5	4 Pixels	Any 4 random pixels per step
	6	6	5 Pixels	Any 5 random pixels per step
	7	7	6 Pixels	Any 6 random pixels per step
	8	8	7 Pixels	Any 7 random pixels per step
	10	10	1,2,3,4 pixels	Pick randomly 1, then 2, then 3, then 4 pixels
	11	11		
	12	12		
	13	13		
	14	14		
	15	15		
	16	16		
	17	17		
	18	18		
	19	19		
	20	20		
	21	21	Lens/SparkFX alternate	Random Lens @ Full, then different Random Strobe section of 4pixels @ Full. Keep all colors strobes, intensities as set by DMX.
	22	22	Alternate Sparx	Alternate evenly (tick/tock/tick/tock) between RGBW Pixel at Full and SparkFX @Full. Keep all colors strobes, intensities as set by DMX.
	23	23	Burst Sparx	Toggles between RGBW Pixel at Full (long on) and SparkFX Full (short flash). Keep all colors strobes, intensities as set by DMX.
	24	24	Alternate Sparx 2	Strobes between RGBW Pixel at Full (short, then off) and SparkFX @ Full (short, then off). Keep all colors strobes, intensities as set by DMX.
	25	25	Burst RGBW	Toggles between RGBW Pixel at Full (short flash) and SparkFX @Full (long on). Keep all colors strobes, intensities as set by DMX.
	26	26		
	27	27		
	28	28		
	29	29		
	30	30		
	31	31		
	32	32		
	33	33		
	34	34		
	35	35		
	36	36		
	37	37		
	38	38		
	39	39		
	40	40		
	41	41		
	42	42		
	43	43		
	44	44		
	45	45		
	46	46		

# COLOR FX TABLE

Features subject to change without notice				
TYPE	SLOT	DMX	NAME	NOTES/STEPS
Intensity	1	1	Single	1,2,3,4,5,6,7,8,9,10,11,12
	2	2	Single Bounce	1,2,3,4,5,6,7,8,9,10,11,12,11,10,9,8,7,6,5,4,3,2
	3	3	2 Pixels	Any two random pixels per step
	4	4	3 Pixels	Any 3 random pixels per step
	5	5	4 Pixels	Any 4 random pixels per step
	6	6	5 Pixels	Any 5 random pixels per step
	7	7	6 Pixels	Any 6 random pixels per step
	8	8	7 Pixels	Any 7 random pixels per step
	10	10	1,2,3,4 pixels	Pick randomly 1, then 2, then 3, then 4 pixels
	11	11		
	12	12		
	13	13		
	14	14		
	15	15		
	16	16		
	17	17		
	18	18		
	19	19		
	20	20		
	21	21	Lens/SparkFX alternate	Random Lens @ Full, then different Random Strobe section of 4pixels @ Full. Keep all colors strobes, intensities as set by DMX.
	22	22	Alternate Sparx	Alternate evenly (tick/tock/tick/tock) between RGBW Pixel at Full and SparkFX @Full. Keep all colors strobes, intensities as set by DMX.
	23	23	Burst Sparx	Toggles between RGBW Pixel at Full (long on) and SparkFX Full (short flash). Keep all colors strobes, intensities as set by DMX.
	24	24	Alternate Sparx 2	Strobes between RGBW Pixel at Full (short, then off) and SparkFX @ Full (short, then off). Keep all colors strobes, intensities as set by DMX.
	25	25	Burst RGBW	Toggles between RGBW Pixel at Full (short flash) and SparkFX @Full (long on). Keep all colors strobes, intensities as set by DMX.
	26	26		
	27	27		
	28	28		
	29	29		
	30	30		
	31	31		
	32	32		
	33	33		
	34	34		
	35	35		
	36	36		
	37	37		
	38	38		
	39	39		
	40	40		
	41	41		
	42	42		
	43	43		
	44	44		
	45	45		
	46	46		

# COLOR FX TABLE

Features subject to change without notice				
TYPE	SLOT	DMX	NAME	NOTES/STEPS
Intensity	47	47		
	48	48		
	49	49		
	50	50		
	51	51		
	52	52		
	53	53		
	54	54		
	55	55		
	56	56		
	57	57		
	58	58		
	59	59		
	60	60		
	61	61		
	62	62		
	63	63		
	64	64		
	65	65		
	66	66		
	67	67		
	68	68		
	69	69		
	70	70		
	71	71		
	72	72		
	73	73		
	74	74		
	75	75		
	76	76		
	77	77		
	78	78		
	79	79		
	80	80		
81	81			
82	82			
83	83			
84	84			
85	85			
86	86			
87	87			
88	88			
89	89			
90	90			
91	91			
92	92			
93	93			
94	94			
95	95			
96	96			
97	97			
98	98			
99	99			
100	100			

# COLOR FX TABLE

Features subject to change without notice				
TYPE	SLOT	DMX	NAME	NOTES/STEPS
Color	101	101	RGBW Cells	Every Pixel Randomly picks a Red, Green, Blue or White on every step
	102	102	RGBWCMY Cells	Every Pixel Randomly picks a Red, Green, Blue, White, Cyan, Magenta, Yellow on every step
	103	103	Color Wheel Cells	Every Pixel Randomly picks a color from the color wheel on every step
	104	104	Red White Cells	Every Cell Randomly picks White or Red on every Step
	105	105	Green White Cells	Every Cell Randomly picks White or Green on every Step
	106	106	Blue White Cells	Every Cell Randomly picks White or Blue on every Step
	107	107	Red Green Cells	Every Cell Randomly picks Red or Green on every Step
	108	108	Red Blue Cells	Every Cell Randomly picks Red or Blue on every Step
	109	109	Blue Green Cells	Every Cell Randomly picks Blue or Green on every Step
	110	110		
	111	111	Random White Cell	RGBW @ Full randomly is set to one cell at a time over the currently mixed color
	112	112	Random White Row	RGBW @ Full randomly is set to one row at a time over the currently mixed color
	113	113	Random White Column	RGBW @ Full randomly is set to one column at a time over the currently mixed color
	114	114	White Flash	RGBW @ Full flashes once over the current mixed color on all Cells
	115	115	Red Flash	Red @ Full flashes once over the current mixed color on all Cells
	116	116	Green Flash	Green @ Full flashes once over the current mixed color on all Cells
	117	117	Blue Flash	Blue @ Full flashes once over the current mixed color on all Cells
	118	118	Color Wheel Flash	Current Color Wheel Color @ Full flashes once over the current mixed color on all Cells
	119	119	Alternate Color	Alternates between mixed color and Color Wheel Color on all cells
	120	120		
	121	121		
	122	122		
	123	123		
	124	124		
	125	125		
	126	126		
	127	127		
	128	128		
	129	129		
	130	130		
131	131			
132	132			
133	133			
134	134			
135	135			
136	136			
137	137			
138	138			
139	139			
140	140			
141	141			
142	142			
143	143			
144	144			
145	145			
146	146			
147	147			
148	148			
149	149			
150	150			

# COLOR FX TABLE

Features subject to change without notice				
TYPE	SLOT	DMX	NAME	NOTES/STEPS
Color	151	151		
	152	152		
	153	153		
	154	154		
	155	155		
	156	156		
	157	157		
	158	158		
	159	159		
	160	160		
	161	161		
	162	162		
	163	163		
	164	164		
	165	165		
	166	166		
	167	167		
	168	168		
	169	169		
	170	170		
	171	171		
	172	172		
	173	173		
	174	174		
	175	175		
	176	176		
	177	177		
	178	178		
	179	179		
	180	180		
	181	181		
182	182			
183	183			
184	184			
185	185			
186	186			
187	187			
188	188			
189	189			
190	190			
191	191			
192	192			
193	193			
194	194			
195	195			
196	196			
197	197			
198	198			
199	199			
200	200			
201	201			
202	202			
203	203			
204	204			
205	205			

# COLOR FX TABLE

Features subject to change without notice				
TYPE	SLOT	DMX	NAME	NOTES/STEPS
Color	206	206		
	207	207		
	208	208		
	209	209		
	210	210		
	211	211		
	212	212		
	213	213		
	214	214		
	215	215		
	216	216		
	217	217		
	218	218		
	219	219		
	220	220		
	221	221		
	222	222		
	223	223		
	224	224		
	225	225		
	226	226		
	227	227		
	228	228		
	229	229		
	230	230		
	231	231		
	232	232		
	233	233		
	234	234		
	235	235		
	236	236		
	237	237		
238	238			
239	239			
240	240			
241	241			
242	242			
243	243			
244	244			
245	245			
246	246			
247	247			
248	248			
249	249			
250	250			
251	251			
252	252			
253	253			
254	254			
255	255			

# SPARKX FX TABLE

Features subject to change without notice			
SLOT	DMX	NAME	NOTES/STEPS
1	1	Starfield	Pixels randomly go on and off with random lengths of on and off times
2	2	Inverse Starfield	Pixels randomly go on and off with random lengths of on and off times
3	3	1 Pixel	1 Random Pixel per Step
4	4	2 Pixels	2 Random Pixels per Step
5	5	3 Pixels	3 Random Pixels per Step
6	6	4 Pixels	4 Random Pixels per Step
7	7	5 Pixels	5 Random Pixels per Step
8	8	6 Pixels	6 Random Pixels per Step
9	9	7 Pixels	7 Random Pixels per Step
10	10	8 Pixels	8 Random Pixels per Step
11	11	Left/Right	All Left then All Right per step
12	12	Mirror	
13	13	Inverse Mirror	
14	14	Knight Rider	
15	15	Marque	
16	16	Center Out	
17	17	Fireworks	
18	18	Ring	
19	19	Row	
20	20	Pairs	Pairs of pixels per step
21	21	Quads	Four pairs of pixels per step
22	22		
23	23		
24	24		
25	25		
26	26		
27	27		
28	28		
29	29		
30	30		
31	31		
32	32		
33	33		
34	34		
35	35		
36	36		
37	37		
38	38		
39	39		
40	40		
41	41		
42	42		
43	43		
44	44		
45	45		
46	46		
47	47		
48	48		
49	49		
50	50		

# SPARKX FX TABLE

Features subject to change without notice			
SLOT	DMX	NAME	NOTES/STEPS
51	51		
52	52		
53	53		
54	54		
55	55		
56	56		
57	57		
58	58		
59	59		
60	60		
61	61		
62	62		
63	63		
64	64		
65	65		
66	66		
67	67		
68	68		
69	69		
70	70		
71	71		
72	72		
73	73		
74	74		
75	75		
76	76		
77	77		
78	78		
79	79		
80	80		
81	81		
82	82		
83	83		
84	84		
85	85		
86	86		
87	87		
88	88		
89	89		
90	90		
91	91		
92	92		
93	93		
94	94		
95	95		
96	96		
97	97		
98	98		
99	99		
100	100		

# SPARKX FX TABLE

Features subject to change without notice			
SLOT	DMX	NAME	NOTES/STEPS
101	101		
102	102		
103	103		
104	104		
105	105		
106	106		
107	107		
108	108		
109	109		
110	110		
111	111		
112	112		
113	113		
114	114		
115	115		
116	116		
117	117		
118	118		
119	119		
120	120		
121	121		
122	122		
123	123		
124	124		
125	125		
126	126		
127	127		
128	128		
129	129		
130	130		
131	131		
132	132		
133	133		
134	134		
135	135		
136	136		
137	137		
138	138		
139	139		
140	140		
141	141		
142	142		
143	143		
144	144		
145	145		
146	146		
147	147		
148	148		
149	149		
150	150		

# SPARKX FX TABLE

Features subject to change without notice			
SLOT	DMX	NAME	NOTES/STEPS
151	151		
152	152		
153	153		
154	154		
155	155		
156	156		
157	157		
158	158		
159	159		
160	160		
161	161		
162	162		
163	163		
164	164		
165	165		
166	166		
167	167		
168	168		
169	169		
170	170		
171	171		
172	172		
173	173		
174	174		
175	175		
176	176		
177	177		
178	178		
179	179		
180	180		
181	181		
182	182		
183	183		
184	184		
185	185		
186	186		
187	187		
188	188		
189	189		
190	190		
191	191		
192	192		
193	193		
194	194		
195	195		
196	196		
197	197		
198	198		
199	199		
200	200		

# SPARKX FX TABLE

Features subject to change without notice			
SLOT	DMX	NAME	NOTES/STEPS
201	201		
202	202		
203	203		
204	204		
205	205		
206	206		
207	207		
208	208		
209	209		
210	210		
211	211		
212	212		
213	213		
214	214		
215	215		
216	216		
217	217		
218	218		
219	219		
220	220		
221	221		
222	222		
223	223		
224	224		
225	225		
226	226		
227	227		
228	228		
229	229		
230	230		
231	231		
232	232		
233	233		
234	234		
235	235		
236	236		
237	237		
238	238		
239	239		
240	240		
241	241		
242	242		
243	243		
244	244		
245	245		
246	246		
247	247		
248	248		
249	249		
250	250		

# SPARKX FX TABLE

Features subject to change without notice			
SLOT	DMX	NAME	NOTES/STEPS
251	251		
252	252		
253	253		
254	254		
255	255		

# COLOR TEMPERATURE

DMX VALUE	COLOR TEMPERATURE (K)	DMX VALUE	COLOR TEMPERATURE (K)
24	2400	55	5500
25	2500	56	5600
26	2600	57	5700
27	2700	58	5800
28	2800	59	5900
29	2900	60	6000
30	3000	61	6100
31	3100	62	6200
32	3200	63	6300
33	3300	64	6400
34	3400	65	6500
35	3500	66	6600
36	3600	67	6700
37	3700	68	6800
38	3800	69	6900
39	3900	70	7000
40	4000	71	7100
41	4100	72	7200
42	4200	73	7300
43	4300	74	7400
44	4400	75	7500
45	4500	76	7600
46	4600	77	7700
47	4700	78	7800
48	4800	79	7900
49	4900	80	8000
50	5000	81	8100
51	5100	82	8200
52	5200	83	8300
53	5300	84	8400
54	5400	85	8500

# VIRTUAL COLORS

VALUE	FILTER #	COLOR	VALUE	FILTER #	COLOR
1	7	Pale Yellow	31	126	Mauve
2	103	Straw	32	49	Medium Purple
3	151	Gold Tint	33	58	Lavender
4	100	Spring Yellow	34	199	Palace Blue
5	10	Medium Yellow	35	119	Dark Blue
6	101	Yellow	36	132	Medium Blue
7	104	Deep Amber	37	120	Deep Blue
8	15	Deep Straw	38	165	Daylight Blue
9	179	Loving Amber	39	161	Slate Blue
10	21	Gold Amber	40	118	Light Blue
11	105	Orange	41	68	Sky Blue
12	158	Deep Orange	42	143	Pale Navy Blue
13	22	Dark Amber	43	131	Marine Blue
14	778	Millennium Gold	44	115	Peacock Blue
15	135	Deep Golden Amber	45	172	Lagoon Blue
16	24	Scarlet	46	116	Medium Blue Green
17	106	Primary Red	47	90	Dark Yellow Green
18	26	Bright Red	48	139	Primary Green
19	27	Medium Red	49	122	Fern Green
20	19	Fire	50	89	Moss Green
21	157	Pink	51	124	Dark Green
22	36	Medium Pink	52	88	Lime Green
23	111	Dark Pink	53	138	Pale Green
24	128	Bright Pink	54	203	Quarter CT Blue
25	148	Bright Rose	55	202	Half CT Blue
26	332	Special Rose Pink	56	201	FULL CT Blue
27	793	Vanity Fair	57	200	Double CT Blue
28	113	Magenta	58	206	Quarter CT Orange
29	46	Dark Magenta	59	205	Half CT Orange
30	48	Rose Purple	60	204	FULL CT Orange

# REMOTE DEVICE MANAGEMENT (RDM)

**NOTE: In order for RDM to work properly, RDM enabled equipment must be used throughout the entire system, including DMX data splitters and wireless systems.**

Remote Device Management (RDM) is a protocol that sits on top of the DMX512 data standard for lighting, allowing the DMX systems of the fixtures to be modified and monitored remotely. This protocol is ideal for instances in which a unit is installed in a location that is not easily accessible.

With RDM, the DMX512 system becomes bi-directional, allowing a compatible RDM enabled controller to send out a signal to devices on the wire, as well as allowing the fixture to respond (known as a GET command). The controller can then use its SET command to modify settings that would typically have to be changed or viewed directly via the unit's display screen, including the DMX Address, DMX Channel Mode, and Temperature Sensors.

## FIXTURE RDM INFORMATION:

RDM Code	Device ID	Device Model ID	Personality ID
22A6	0072	005A	Standard (22) Extend (30) Pixels (70)

**Please be aware that not all RDM devices support all RDM features,** and therefore it is important to check beforehand to ensure that the equipment that you are considering includes all of the features that you require.

The following parameters are accessible in RDM on this device:

[0x0200] Sensor Definition	[0x0602] Pan Tilt Swap
[0x0201] Sensor Value	[0x0500] Display Invert
[0x0080] Device Model Description	[0x0501] Display Level
[0x0081] Manufacturer Label	[0x0603] Realtime Clock
[0x0082] Device Label	[0x1010] Power State
[0x00E0] DMX Personality	[0x1031] Preset Playback
[0x00E1] DMX Personality Description	[0x0122] Default Slot Value
[0x0400] Device Hours	[0x00B0] Language
[0x0015] Comms Status	[0x00A0] Language Capabilities
[0x0031] Status ID Description	[0x00C2] Boot Software Version Label
[0x0032] Clear Status ID	[0x00C1] Boot Software Version ID
[0x0402] Lamp Strikes	[0x0070] Product Detail ID List
[0x0404] Lamp Mode	[0x0030] Status Messages
[0x0405] Device Power Cycles	[0x1001] Reset Device
[0x0600] Pan Invert	[0x0014] Undefined PID [0x0014,(20)]
[0x0601] Tilt Invert	

# MAINTENANCE GUIDELINES



**DISCONNECT POWER BEFORE PERFORMING ANY MAINTENANCE!**

## CLEANING

Frequent cleaning is recommended to ensure proper function, optimized light output, and an extended life. The frequency of cleaning depends on the environment in which the fixture operates: damp, smoky or particularly dirty environments can cause greater accumulation of dirt on the fixture's optics. Periodically clean the external lens surface with a soft cloth to avoid dirt/debris accumulation. **NEVER** use alcohol, solvents, or ammonia-based cleaners.

## MAINTENANCE

Regular inspections are recommended to ensure proper function and extended life. There are no user serviceable parts inside this fixture. Please refer all other service issues to an authorized Elation service technician. Should you need any spare parts, please order genuine parts from your local Elation dealer.

Please refer to the following points during routine inspections:

- A detailed electric check by an approved electrical engineer every three months, to make sure the circuit contacts are in good condition and prevent overheating.
- Be sure all screws and fasteners are securely tightened at all times. Loose screws may fall out during normal operation, resulting in damage or injury as larger parts could fall.
- Check for any deformations on the housing, color lenses, rigging hardware, and rigging points (ceiling, suspension, trussing). Deformations in the housing could allow for dust to enter into the fixture. Damaged rigging points or unsecured rigging could cause the fixture to fall and seriously injure a person(s).
- Electric power supply cables must not show any damage, material fatigue or sediments. **NEVER** remove the ground prong from the power cable.

## FIXTURE DISASSEMBLY

The following points should be observed after performing any maintenance procedure that requires disassembly of the unit:

- After the unit has been reassembled, open the valve and allow the unit to run for approximately 2 hours in order to dry out any moisture that has been trapped inside the fixture. The process should continue until indicated humidity drops below 15% for the head and 30% for the base.
- Once this has been achieved, the light can be switched off, but the unit should remain connected to power so that the cooling fan can cool down the unit. Please note that allowing cool down time should **ALWAYS** be done after lamp operation.
- Some units may require partial disassembly in order to gain access to the valve. Please contact Elation service for information regarding the location and access procedure for the valve on your specific unit model.

# ERROR CODES

Error Codes subject to change without notice	
ERROR CODES	DESCRIPTION
Tilt1	Movement is not located in the default position after the reset. These messages will appear after a fixture reset if the magnetic-indexing circuit malfunctions (sensor failed, or magnet is missing) or there is a motor failure (defective motor or a defective motor IC drive on the main PCB). This error may also be displayed if the head/yoke was blocked during a reset function.
Tilt2	
LEDTemp1	Movement is not located in the default position after the reset. These messages will appear after a fixture reset if the magnetic-indexing circuit malfunctions (sensor failed, or magnet is missing) or there is a motor failure (defective motor or a defective motor IC drive on the main PCB).
LEDTemp2	
LEDFan1	
LEDFan2	
LEDFan3	
Zoom	
BaseFan1	
BaseTemp	These messages will appear if there is a temperature and/or fan malfunction.
LEDFan1	
LEDFan2	
LEDFan3	
BaseFan4	

# SOFTWARE UPDATES



**ONLY QUALIFIED TECHNICIANS SHOULD PERFORM THIS FUNCTION!  
NOTE ALL MENU SETTINGS BEFORE UPDATING SOFTWARE!  
FIXTURE SOFTWARE CAN NOT BE DOWNGRADED!  
DOWNLOAD FIXTURE SOFTWARE TO PC ONLY! (NO MAC SUPPORT)  
PLEASE CONTACT ELATION SERVICE FOR FURTHER INFORMATION.**

## **C-LOADER II**

An Elation C-Loader II can be used to update the fixture to the latest software. Please visit the C-Loader II product page at the Elation web site and download the product manual for step by step instructions.

<https://www.elationlighting.com/c-loader-software-uploader>

To order the C-Loader II uploader and the updated software for your fixture, please contact Elation support for details.

**ELATION SERVICE USA - Monday - Friday 8:00am to 4:30pm PST**  
**323-582-3322 | support@elationlighting.com**

**ELATION SERVICE EUROPE - Monday - Friday 08:30 to 17:00 CET**  
**+31 45 546 85 63 | support@elationlighting.eu**

# SPECIFICATIONS

## SOURCE

(8) 60W RGBL LEDs  
(16) 5W CW SparkX LED Pixels  
30,000 Hour Average LED Life\*

\*Test lab conditions. May vary depending on several factors including but not limited to: Environmental Conditions, Power/Voltage, Usage Patterns (On-Off Cycling), Control, and Dimming.

## PHOTOMETRIC DATA

Total Lumen Output:  
Integrating Sphere  
All LED: 11,548 Lumens  
RGBL LED: 7,128 Lumens  
CW LED: 4,752 Lumens  
CRI 82  
Zoom Range 4° - 35°

## EFFECTS

Motorized Zoom  
Full Pixel LED Control  
SparkX LED Beam Effect  
Electronic Dimmer and Strobe  
Variable 16-bit Dimming Modes and Curves  
Tilt Angle: 210°

## COLOR

RGBL LED Array  
CW SparkX LED Array  
Variable CCT 2400K - 8500K  
Virtual Gel Swatch Book

## CONTROL / CONNECTIONS

3 DMX Channel Modes (22/30/70 channels)  
DMX Adjustable Refresh Rate (900 -25000 Hz)  
4 Button Control Panel, LED Display  
Aria x2 Wireless Device Management  
NFC Configuration  
DMX, RDM, Art-NET, sACN Protocol Support  
IP65 Locking 5pin XLR Connector In/Out  
IP65 Locking RJ45 Ethernet Connector In/Out  
IP65 Locking Power Cable In/Out

## SIZE / WEIGHT

Length: 19.8 in (502mm)  
Width: 6.5 in (164mm)  
Height (head up): 13.2 in (336mm)  
Height (head 90 degree): 10.0 in (254mm)  
Weight: 29.3 lb (13.3 kg)

## ELECTRICAL / THERMAL

AC 100-240V 50/60Hz  
810W Max Power Consumption  
Ambient Temperature Range: -4°F to 113°F  
(-20°C to 45°C)  
BTU/hr (+/- 10%) 2762.1

## INCLUDED ITEMS

Omega Brackets (x2)  
Blank Name Plate  
Front Louver/Grid  
Diffusion Filter  
Safety Cable IP65 Rated  
IP65 Locking Power Cable

## APPROVALS / RATINGS

CE | cETLus | IP55 | FCC | UKCA



# DIMENSIONS

\*Drawings not to scale. Specifications and improvements in the design of this unit and this manual are subject to change without notice.

## W/O FROST FILTER

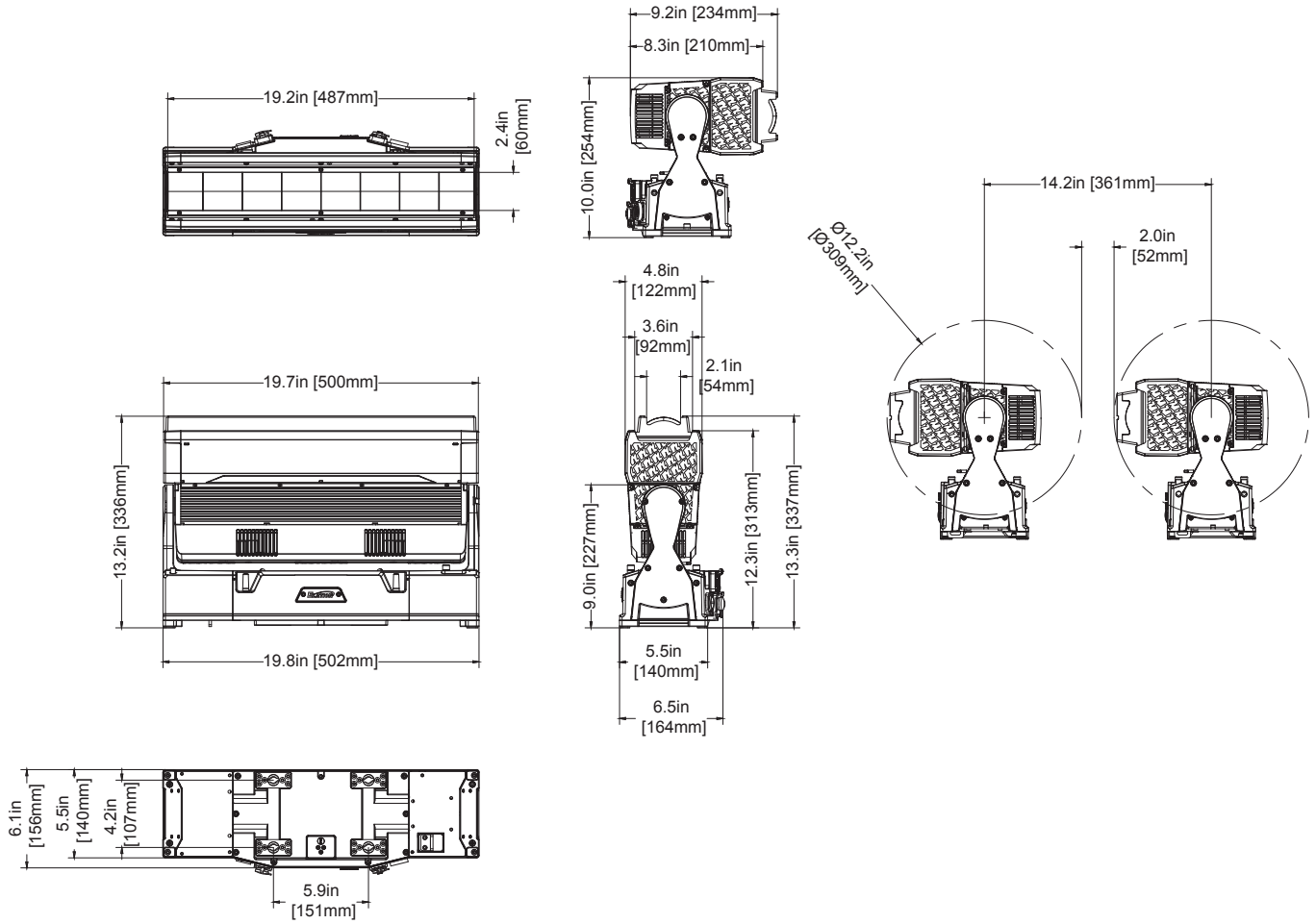

## WITH FROST FILTER

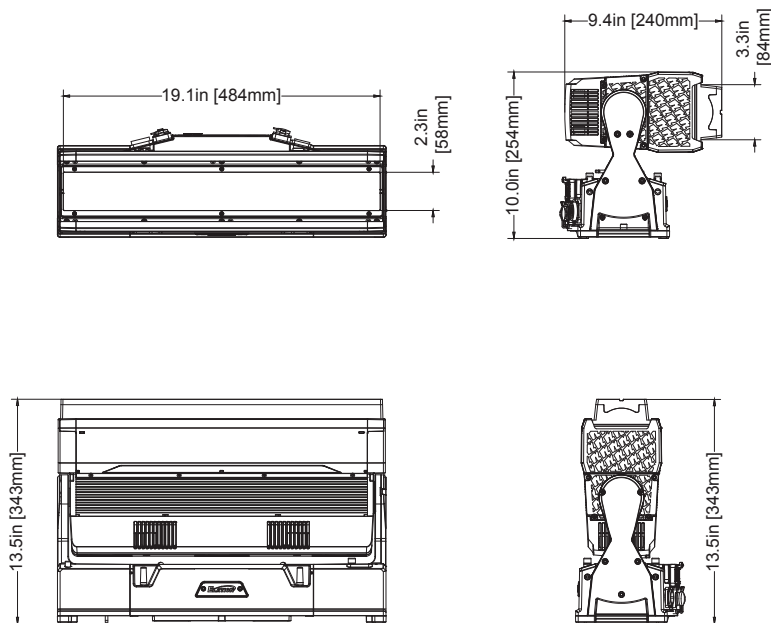

# OPTIONAL ACCESSORIES

ORDER CODE	ITEM
TRIGGER CLAMP	Heavy Duty Wrap Around Hook Style Clamp
SIP126	5 ft. (1.5m) IP55 Twist Lock Power Link Cable
TOU027	5 ft. (1.5m) 5pin PRO DMX Cable
	Additional Cable Lengths Available

## FCC STATEMENT

This device complies with Part 15 of the FCC Rules. Operation is subject to the following two conditions: (1) this device may not cause harmful interference, and (2) this device must accept any interference received, including interference that may cause undesired operation.

### FCC RADIO FREQUENCY INTERFERENCE WARNINGS & INSTRUCTIONS

This product has been tested and found to comply with the limits as per Part 15 of the FCC Rules. These limits are designed to provide reasonable protection against harmful interference in a residential installation. This device uses and can radiate radio frequency energy and, if not installed and used in accordance with the included instructions, may cause harmful interference to radio communications. However, there is no guarantee that interference will not occur in a particular installation. If this device does cause harmful interference to radio or television reception, which can be determined by turning the device off and on, the user is encouraged to try to correct the interference by one or more of the following methods:

- Reorient or relocate the device.
- Increase the separation between the device and the receiver.
- Connect the device to an electrical outlet on a circuit different from which the radio receiver is connected.
- Consult the dealer or an experienced radio/TV technician for help.

### Energy Saving Matters (EuP 2009/125/EC)

Saving electric energy is a key to help protecting the environment. Please turn off all electrical products when they are not in use. To avoid power consumption in idle mode, disconnect all electrical equipment from power when not in use. Thank you!



