

# **ELATION®**

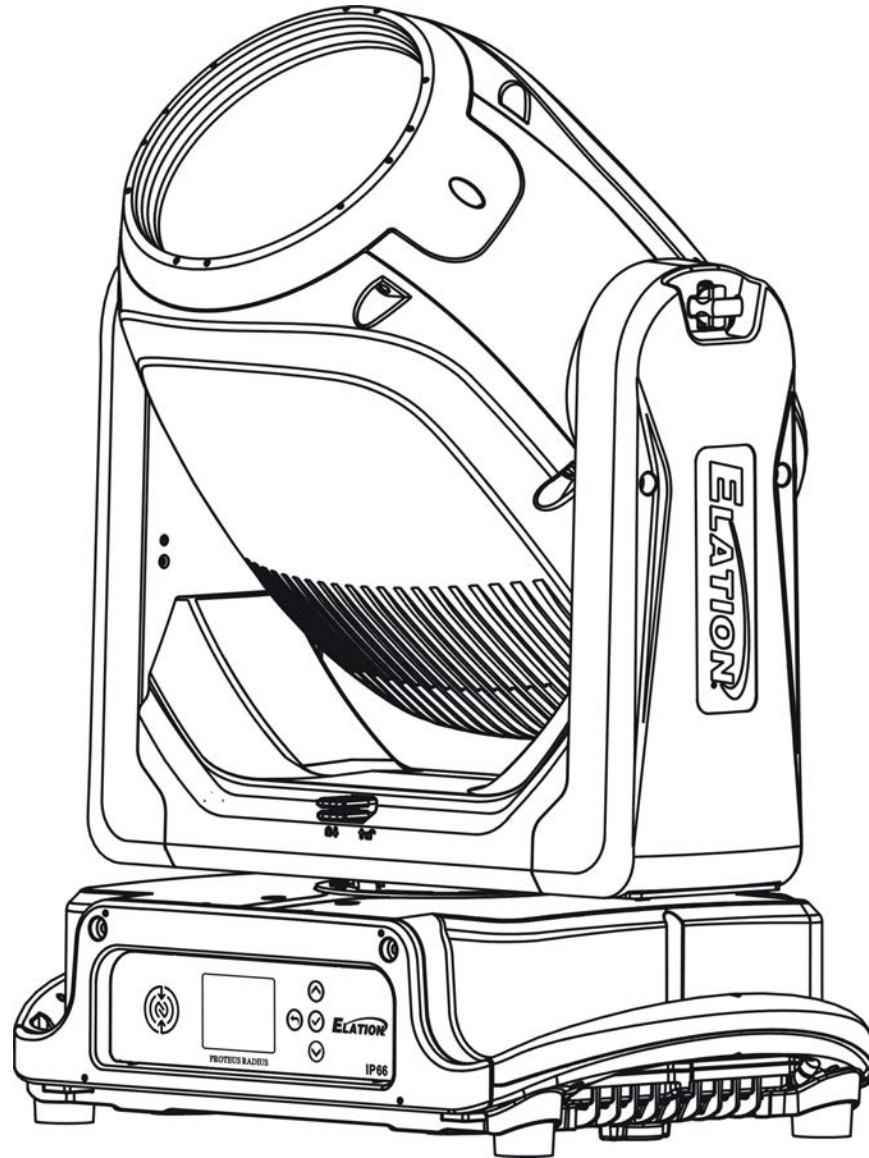

## **PROTEUS RADIUS**

### **user manual**

©2026 ELATION PROFESSIONAL all rights reserved. Information, specifications, diagrams, images, and instructions herein are subject to change without notice. ELATION PROFESSIONAL logo and identifying product names and numbers herein are trademarks of ELATION PROFESSIONAL. Copyright protection claimed includes all forms and matters of copyrightable materials and information now allowed by statutory or judicial law or hereinafter granted. Product names used in this document may be trademarks or registered trademarks of their respective companies and are hereby acknowledged. All non-ELATION brands and product names are trademarks or registered trademarks of their respective companies.

**ELATION PROFESSIONAL** and all affiliated companies hereby disclaim any and all liabilities for property, equipment, building, and electrical damages, injuries to any persons, and direct or indirect economic loss associated with the use or reliance of any information contained within this document, and/or as a result of the improper, unsafe, insufficient and negligent assembly, installation, rigging, and operation of this product.

**Elation Professional USA | 6122 S. Eastern Ave. | Los Angeles, CA. 90040**  
 323-582-3322 | [www.elationlighting.com](http://www.elationlighting.com) | [info@elationlighting.com](mailto:info@elationlighting.com)

**Elation Professional B.V. | Junostraat 2 | 6468 EW Kerkrade, The Netherlands**  
 +31 45 546 85 66 | [www.elationlighting.eu](http://www.elationlighting.eu) | [info@elationlighting.eu](mailto:info@elationlighting.eu)

**Elation Professional Mexico | AV Santa Ana 30 | Parque Industrial Lerma, Lerma, Mexico 52000**  
 +52 (728) 282-7070

**DOCUMENT VERSION**



Due to additional product features and/or enhancements, an updated version of this document may be available online. Please scan the QR Code with your mobile device or visit [www.elationlighting.com](http://www.elationlighting.com) for the latest revision/update of this manual, before installation and/or programming.

Date	Document Version	Software Version	DMX Channels	Notes
01/25/2024	1.0	1.0.0	26/36	Initial release
01/26/2024	1.1	N/C	No Change	Updated Overview
03/14/2024	1.2	N/C	No Change	Updated Colors and Gobos
05/02/2024	1.3	N/C	No Change	Updated Safety Warnings
08/02/2024	1.4	N/C	No Change	Updated Torque Screws, Colors and Gobos, Optional Accessories
11/19/2024	1.5	N/C	No Change	Updated Overview, Specifications, Dimensional Drawings
04/23/2025	1.6	N/C	No Change	Updated Introduction, IP66 Rated, Safety Guidelines, Overview, Colors & Gobos, Gobo Installation, Fan Modes, System Menu, Specifications
07/15/2025	1.7	N/C	No Change	Update laser logos for FDA requirement
08/28/2025	1.8	N/C	No Change	Added Sky Motion Instructions
11/06/2025	1.9	N/C	No Change	Updated IP66 Rated
12/15/2025	2.0	N/C	No Change	Update Class 1 Risk warning
06/01/2026	2.1	N/C	No Change	Updated: General Info; Added Index; Removed Zone Restriction

# CONTENTS

<b>General Information</b>	<b>4</b>
<b>IP66 Rated</b>	<b>5</b>
<b>Safety Guidelines</b>	<b>6</b>
<b>Overview</b>	<b>8</b>
<b>Colors and Gobos</b>	<b>10</b>
<b>Custom Gobos</b>	<b>12</b>
<b>Gobo Installation</b>	<b>13</b>
<b>Torque Settings for Screws</b>	<b>14</b>
<b>IP Test Parameters</b>	<b>15</b>
<b>Installation Guidelines</b>	<b>16</b>
<b>Sun Protection Mode   Hibernation Mode</b>	<b>22</b>
<b>Fan Modes and Low Noise Operation</b>	<b>23</b>
<b>Sky Motion</b>	<b>24</b>
<b>System Menu</b>	<b>26</b>
<b>Dimmer Modes and Dimmer Curves</b>	<b>32</b>
<b>DMX Traits: Channel Functions &amp; Values</b>	<b>33</b>
<b>Remote Device Management (RDM)</b>	<b>41</b>
<b>Error Codes</b>	<b>42</b>
<b>Software Updates</b>	<b>43</b>
<b>Maintenance Guidelines</b>	<b>48</b>
<b>Specifications</b>	<b>49</b>
<b>Dimensional Drawings</b>	<b>50</b>
<b>Optional Accessories</b>	<b>52</b>
<b>Index</b>	<b>53</b>

# GENERAL INFORMATION

## FOR PROFESSIONAL USE ONLY

### INTRODUCTION

Please read and understand the instructions in this manual carefully and thoroughly before attempting to operate this device. These instructions contain important safety and use information.

### COOLING

After usage, the lamp may be switched off, but the fixture should remain connected to power in order to allow the fan time to cool down the fixture.

### UNPACKING

Every device has been thoroughly tested and has been shipped in perfect operating condition. Carefully check the shipping carton for damage that may have occurred during shipping. If the carton is damaged, carefully inspect the device for damage, and be sure all accessories necessary to install and operate the device have arrived intact. In the event damage has been found or parts are missing, please contact our customer support team for further instructions. Please do not return this device to your dealer without first contacting customer support. Please do not discard the shipping carton in the trash. Please recycle whenever possible.

### BOX CONTENTS

Omega Brackets (x2)

IP65 Rated 5-pin DMX Cable (x1)

IP65 Rated RJ45 Data Cable (x1) - **FIXTURE TO FIXTURE INTERCONNECTION USE ONLY!**

IP65 Locking Power Cable (x1)

### CUSTOMER SUPPORT

Contact ELATION Service for any product related service and support needs.

Also visit [forums.elationlighting.com](https://forums.elationlighting.com) with questions, comments or suggestions.

**ELATION SERVICE USA - Monday - Friday 8:00am to 4:30pm PST**

**323-582-3322 | [support@elationlighting.com](mailto:support@elationlighting.com)**

**ELATION SERVICE EUROPE - Monday - Friday 08:30 to 17:00 CET**

**+31 45 546 85 63 | [support@elationlighting.eu](mailto:support@elationlighting.eu)**

**REPLACEMENT PARTS** please visit [parts.elationlighting.com](https://parts.elationlighting.com)

### LIMITED WARRANTY

For up-to-date warranty information regarding your device, please visit Elation's warranty information page online or scan the QR codes below.



**USA: <https://www.elationlighting.com/warranty-information>**



**EU: [https://www.elationlighting.eu/terms\\_and\\_conditions](https://www.elationlighting.eu/terms_and_conditions)**

**It is strongly recommended to power the fixture down completely when not in use. Doing so will reduce wear on the fixture due to sustained or extended operational periods, thereby maximizing its operational lifespan.**

# IP66 RATED

**The International Protection (IP)** rating system is commonly expressed as “IP” (Ingress Protection) followed by two numbers (i.e. IP66), where the numbers define the degree of protection. The first digit (Foreign Bodies Protection) indicates the extent of protection against particles entering the fixture, and the second digit (Water Protection) indicates the extent of protection against water entering the fixture. An **IP66** rated lighting fixture is designed and tested to protect against the ingress of dust (**6**), and high-pressure water jets from any direction (**6**).

**Maritime/Seaside Environment Installations:** A maritime/seaside environment is adjacent to the sea and caustic to electronics through exposure to atomized salt water and humidity, whereas a coastal environment extends 5 miles inland.

Maritime installations require additional preparation, and additional service intervals may be needed given the maritime use. In general, IP ratings presuppose freshwater conditions VS maritime conditions, which are typically more “caustic” to IP fixtures (both internally and externally). A duty-cycle may also be needed when units are not in use. During times of high humidity and colder temperatures, condensation may occur internally so the fixture may require a duty-cycle to bring it up to running temperature, allowing any accumulation of moisture to be expelled via the vent valve. Recommendations can change based on installation environmental circumstances.

**NOTE: NOT ALL FEATURES LISTED ARE AVAILABLE ON ALL FIXTURES; THE FOLLOWING INSTRUCTIONS MAY NOT APPLY. CONTACT SUPPORT FOR ADDITIONAL DETAILS.**

**Exterior Maintenance:** Inspect the exterior every 30-days. The unit must be powered off/disconnected. The chassis should be inspected for any signs of contaminants. Inspect optics to determine if the lens is obstructed, then clean optics and chassis accordingly. Based on initial finding, schedule maintenance accordingly, keeping in mind that exterior maintenance will be required. Even if the luminaires are NOT in use, maintenance will still be needed given its location (exterior use). The use of a durable type of wax on the chassis is recommended since it will help prevent contaminant build up. Inspect both power and data lines for any signs of contaminants or corrosion. Periodically reapplying di-electric grease, especially in coastal environments. If any signs of corrosion/contaminants are present, clean thoroughly, and/or replace connectors, then reapply di-electric grease. Typically, this should be done annually, or any time an opportunity presents itself. As a preventive measure, annual replacement of both vent valves is recommended. The vent valve membrane can become contaminated and/or clogged causing improper venting of humidity within the luminaire. Inspect all mounting hardware as a precaution.

**Interior Maintenance:** Inspect the interior every 30-days. The unit must be powered off/disconnected.

- Inspect zoom/focus mechanism, clean optics, lubricate linear bearings (Krytox oil) as needed, inspect belts for wear
- Inspect all rotating effect wheels, manually rotate them, note any resistance
- Inspect all remaining rotating belts for any wear
- Inspect all fans, clean as needed, check rotation, check connections
- Inspect CMY module, manually move flags and check for signs of resistance, and if needed, clean guide rods first, then reapply a thin layer of grease (moly lube)
- Clean interior with low-volume compressed air, then clean optics prior to reassembly of head covers

Although the base has limited moving parts, the pan belt should also be inspected for wear. Remember to always perform an IP test anytime a cover is removed.

There is no specific time frame regarding the routine replacement of parts such as belts/stepper motors, PCBs, or LEDs. These items should only be replaced on an as needed bases, except for cooling fans, which should be replaced once the luminaries reach 10,000-hours. This is a prophylactic measure intended to keep the unit running as cool as possible, insuring proper function of all internal components. A complete service breakdown is available, please contact [service@elationlighting.com](mailto:service@elationlighting.com) for any needed parts or manuals.

# SAFETY GUIDELINES

This fixture is a sophisticated piece of electronic equipment. To guarantee a smooth operation, it is important to follow all instructions and guidelines in this manual. Elation Professional is not responsible for injury and/or damages resulting from the misuse of this fixture due to the disregard of the information printed in this manual. Only qualified and/or certified personnel should perform installation of this fixture and only the original rigging parts (omega brackets) included with this fixture should be used for installation. Any modifications to the fixture and/or the included mounting hardware will void the original manufacturer's warranty and increase the risk of damage and/or personal injury.



**CLASS 1 RISK GROUP 2 PRODUCT PER IEC 62471 - Devices classified as Class 1 Risk Group 2 present no photobiological hazard under normal operating conditions or reasonably foreseeable conditions of misuse.**

Class 1 RG2 fixtures, classified by the FDA, present a moderate risk due to their light intensity and spectral properties, but natural aversion responses, such as the blink reflex, generally provide protection against momentary exposure. Although within Class 1 safety limits, direct and prolonged exposure to these beams should be avoided to reduce the potential for eye discomfort, while static, unmodified high-intensity beams into the audience are not recommended.



**NOT FOR HOUSEHOLD USE**



**PROTECTION CLASS 1 - FIXTURE MUST BE PROPERLY GROUNDED**



**CLASS 1 LASER PRODUCT - COMPLIES WITH 21CFR1040.10 AND 1040.11 EXCEPT FOR CONFORMANCE WITH IEC 60825-1 ED3., AS DESCRIBED IN LASER NOTICE NO. 56, DATED MAY 8 2019**



**THERE ARE NO USER SERVICEABLE PARTS INSIDE THIS UNIT. DO NOT ATTEMPT ANY REPAIRS YOURSELF; DOING SO WILL VOID YOUR MANUFACTURER'S WARRANTY. DAMAGES RESULTING FROM MODIFICATIONS TO THIS FIXTURE AND/OR THE DISREGARD OF SAFETY INSTRUCTIONS AND GUIDELINES IN THIS MANUAL VOID THE MANUFACTURE'S WARRANTY AND ARE NOT SUBJECT TO ANY WARRANTY CLAIMS AND/OR REPAIRS.**



**ENSURE ALL CONNECTIONS AND END CAPS ARE PROPERLY SEALED WITH A DIELECTRIC GREASE (AVAILABLE AT MOST ELECTRICAL SUPPLIERS) TO PREVENT WATER CORROSION AND/OR ELECTRICAL SHORT CIRCUIT.**



**DO NOT PLUG FIXTURE INTO A DIMMER PACK!  
NEVER OPEN THIS FIXTURE WHILE IN USE!  
UNPLUG POWER BEFORE SERVICING FIXTURE!  
NEVER TOUCH FIXTURE DURING OPERATION, AS IT MAY BE HOT!  
KEEP FLAMMABLE MATERIALS AWAY FROM FIXTURE!**



**NEVER LOOK DIRECTLY INTO THE LIGHT SOURCE! HIGH RISK OF EYE DAMAGE. RETINA INJURY RISK - MAY INDUCE BLINDNESS!  
SENSITIVE PERSONS MAY SUFFER AN EPILEPTIC SHOCK!**



**MINIMUM DISTANCE TO LIGHTED OBJECTS 20.0 METERS.  
MAXIMUM TEMPERATURE OF THE EXTERNAL SURFACE 75 °C.  
MINIMUM DISTANCE OF FLAMMABLE MATERIALS FROM THE SURFACE 0.5M.  
MINIMUM DISTANCE FROM FIXTURE HEAD TO COMBUSTIBLE MATERIALS 0.1M.**

# SAFETY GUIDELINES

- **DO NOT TOUCH** the fixture housing during operation. Turn OFF the power and allow approximately 15 minutes for the fixture to cool down before serving.
- **DO NOT** shake fixture, avoid brute force when installing and/or operating fixture.
- **DO NOT** operate fixture if the power cord is frayed, crimped damaged and/or if any of the power cord connectors are damaged and do not insert into the fixture securely with ease.
- **NEVER** force a power cord connector into the fixture. If the power cord or any of its connectors are damaged, replace it immediately with a new one of similar power rating.
- **DO NOT** block any air ventilation slots.
- All fan and air inlets must remain clean and never blocked.
- Allow approx. 10''(25cm) between fixture and other devices or a wall for proper cooling.
- When installing fixture in a suspended environment, always use mounting hardware that is no less than M10x25mm, and always install fixture with an appropriately rated safety cable.
- Always disconnect fixture from main power source before performing any type of service and/or cleaning procedure. Only handle the power cord by the plug end, never pull out the plug by tugging the wire portion of the cord.
- During the initial operation of this fixture, a light smoke or smell may emit from the interior of the fixture. This is a normal process and is caused by excess paint in the interior of the casing burning off from the heat associated with the lamp and will decrease gradually over time.
- Consistent operational breaks will ensure the fixture will function properly for many years.
- **ONLY** use the original packaging and materials to transport the fixture in for service.

# OVERVIEW

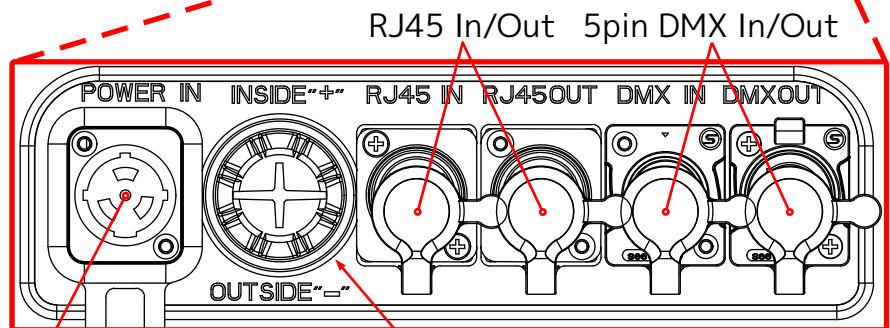
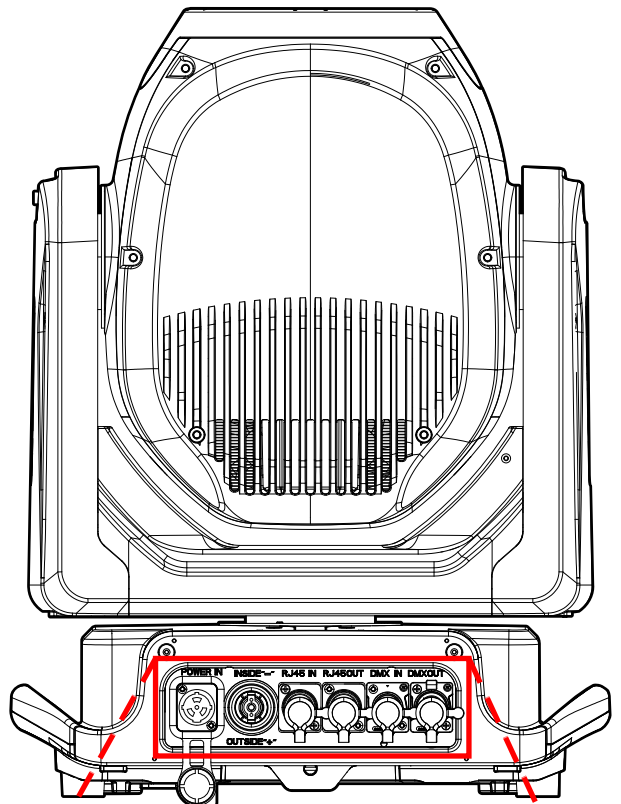
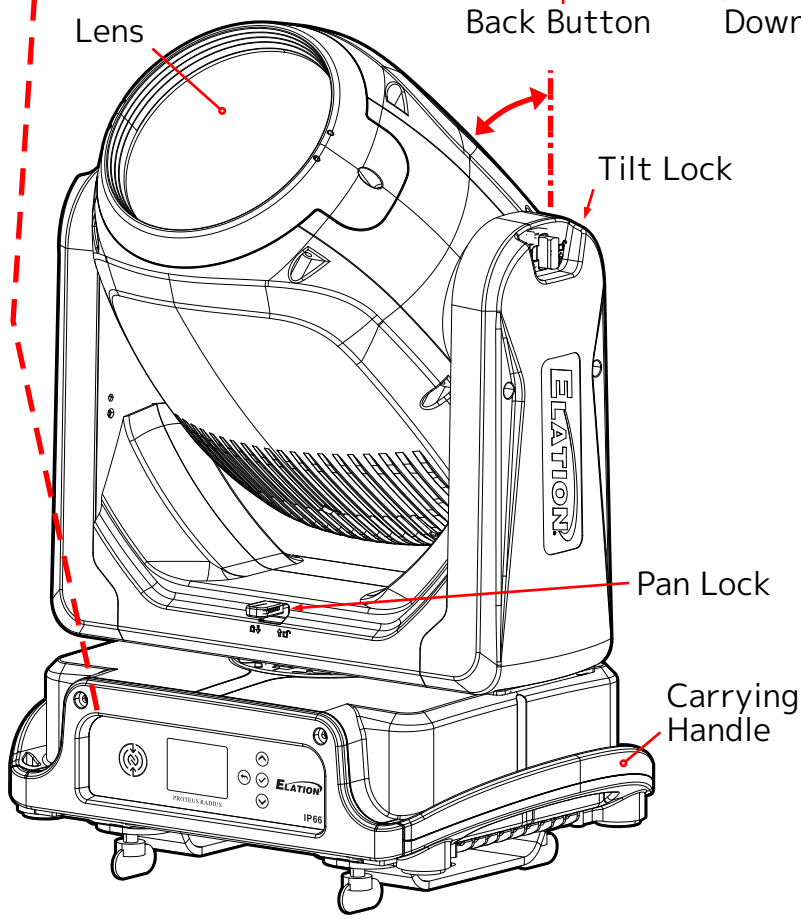
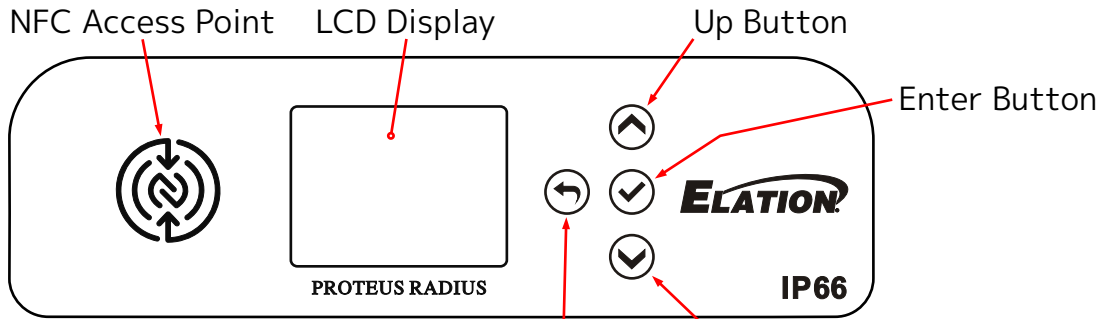

NOTE: TO MAINTAIN THE IP66 RATING INTEGRITY OF THE FIXTURE AND PREVENT WATER FROM ENTERING THE FIXTURE, SEAL ALL UNUSED CONNECTION RUBBER CAPS.

Power In    Battery Compartment

# OVERVIEW

## WARNING LABELS

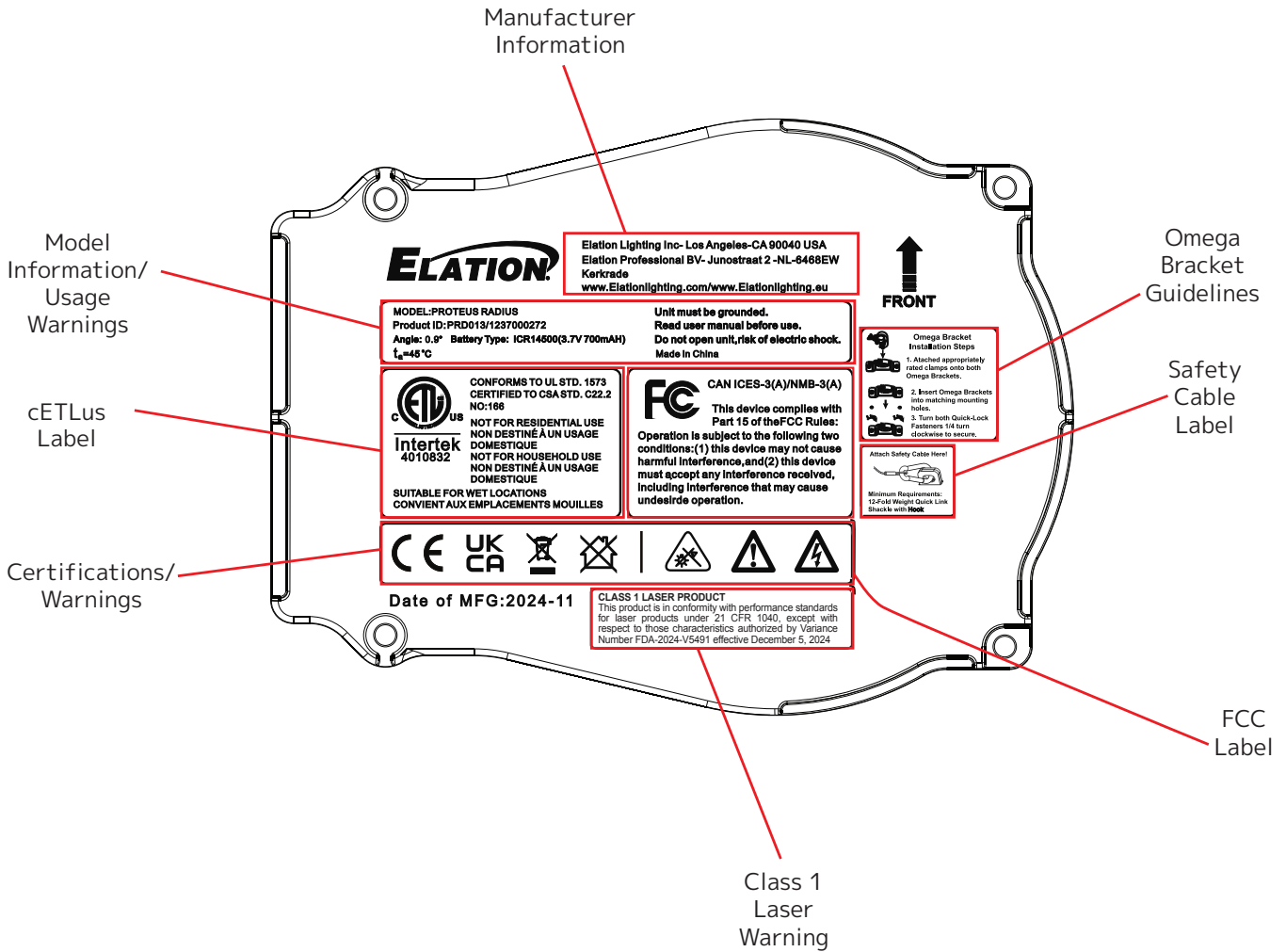
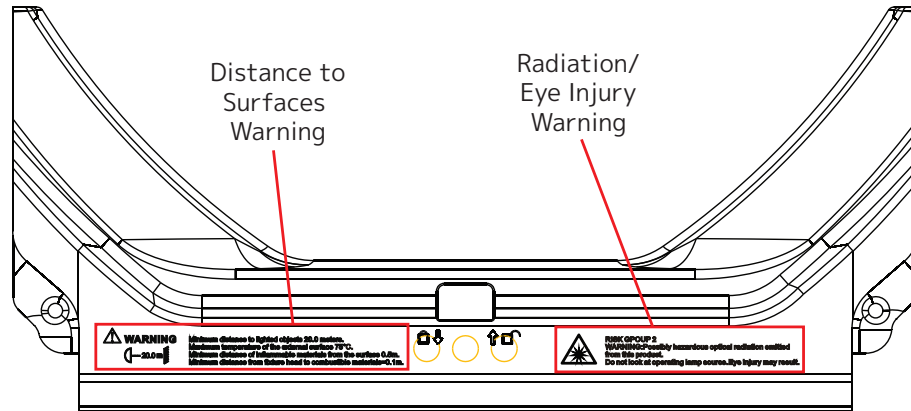

# COLORS AND GOBOS

## COLOR FLAGS

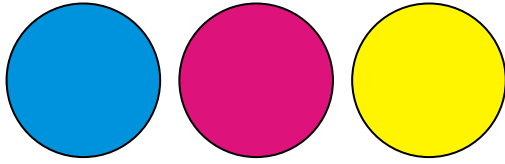

CYAN      MAGENTA      YELLOW

## COLOR WHEEL

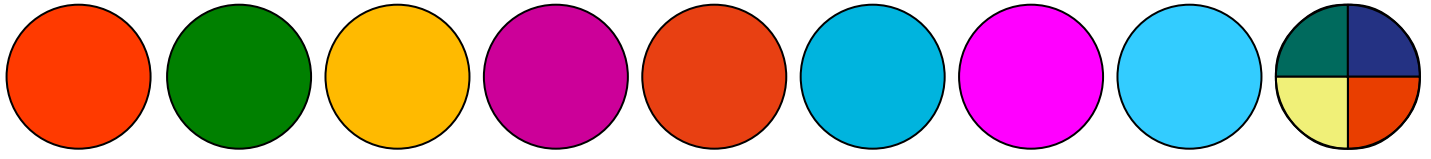

POS 1 RED      POS 2 GREEN      POS 3 YELLOW      POS 4 MAGENTA      POS 5 ORANGE      POS 6 CYAN II      POS 7 PINK      POS 8 CYAN      POS 9 QUAD COLOR

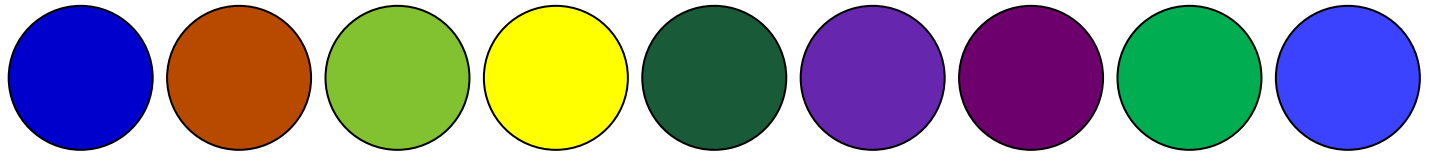

POS 10 DEEP BLUE      POS 11 AMBER      POS 12 YELLOW GREEN      POS 13 LIGHT YELLOW      POS 14 GREEN II      POS 15 LAVENDER      POS 16 WINE PINK      POS 17 KELLY GREEN      POS 18 LIGHT BLUE

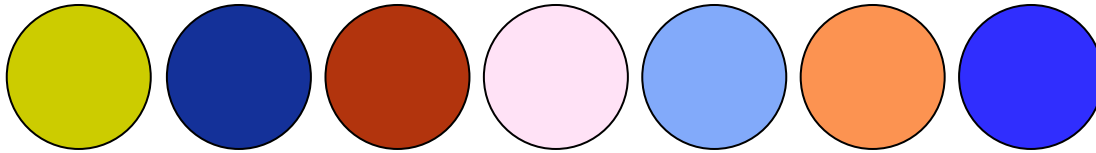

POS 19 DEEP YELLOW      POS 20 BLUE II      POS 21 RED AMBER      POS 22 HCRI      POS 23 CTB      POS 24 CTO      POS 25 BLUE

## INTERCHANGEABLE ROTATING GOBO WHEEL 1

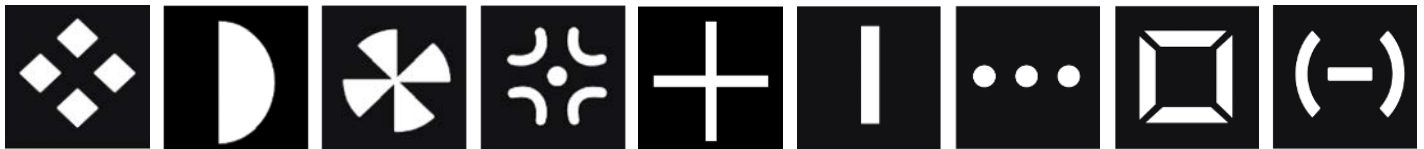

POS 1      POS 2      POS 3      POS 4      POS 5      POS 6      POS 7      POS 8      POS 9



POS 10      POS 11      POS 12      POS 13

# COLORS AND GOBOS

## FIXED GOBO WHEEL

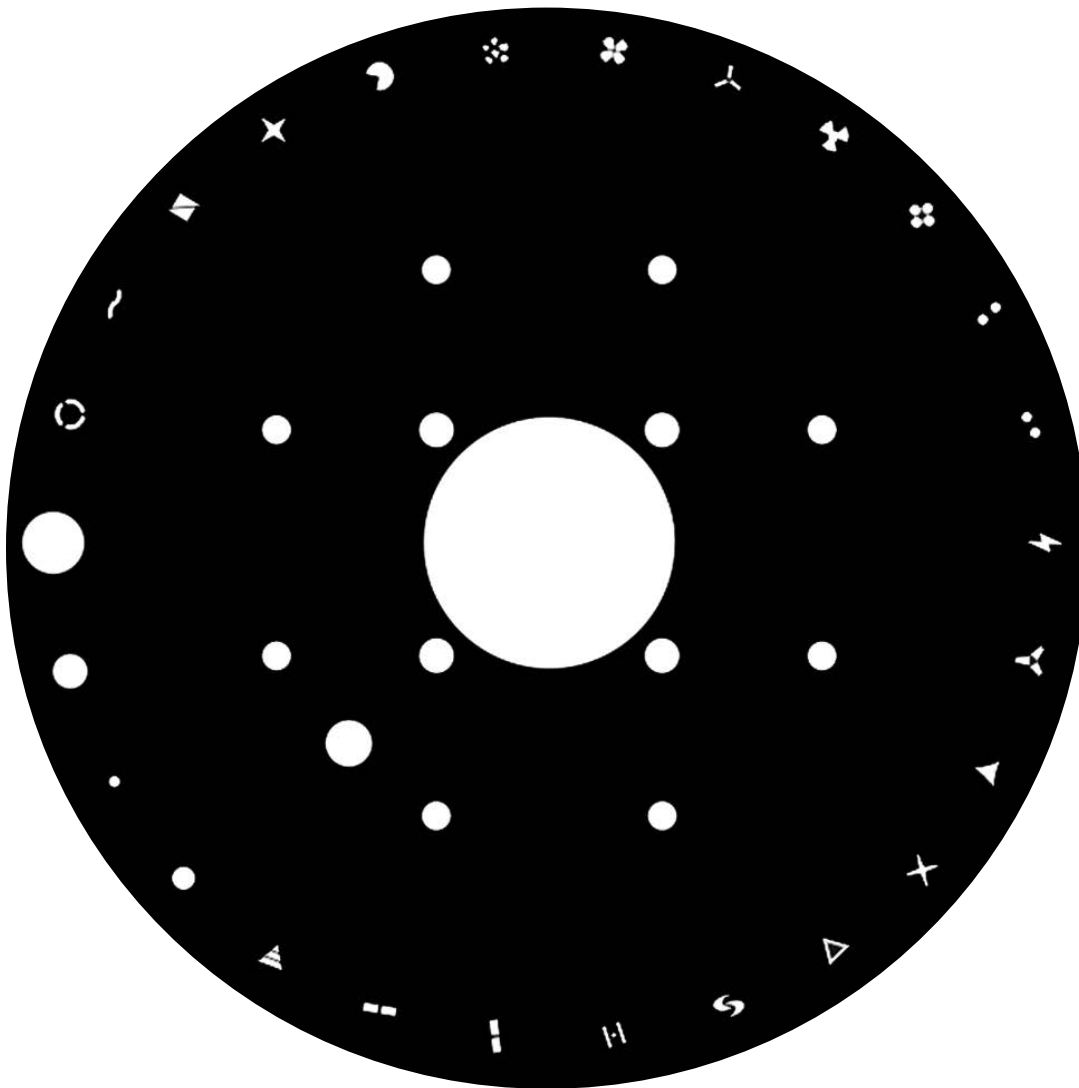
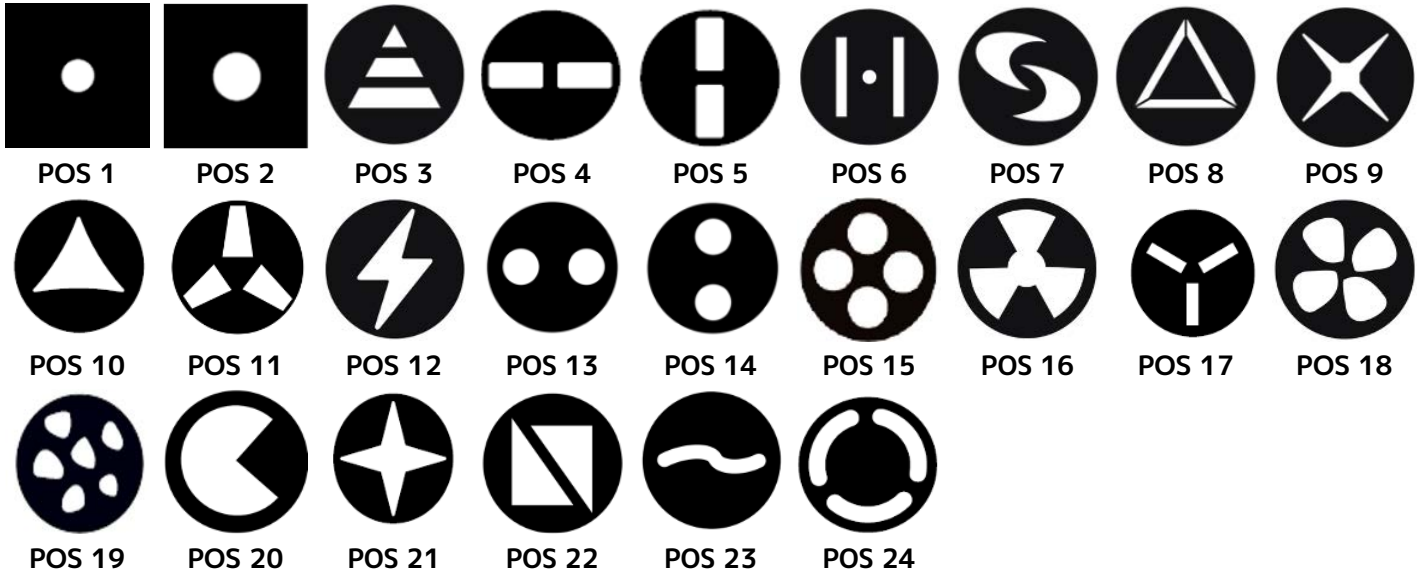

# CUSTOM GOBOS



Custom Gobos can only be installed by technicians certified by Elation for LILI systems. This document outlines specifications for custom gobo design.

<b>ROTATING GOBO WHEEL GOBOS</b>	
Gobo O.D. (Max. Outer Diameter)	Ø7.0mm
Gobo I.D. (Max. Image Diameter)	Ø3mm
Gobo Thickness	.5mm
Gobo Material	METAL

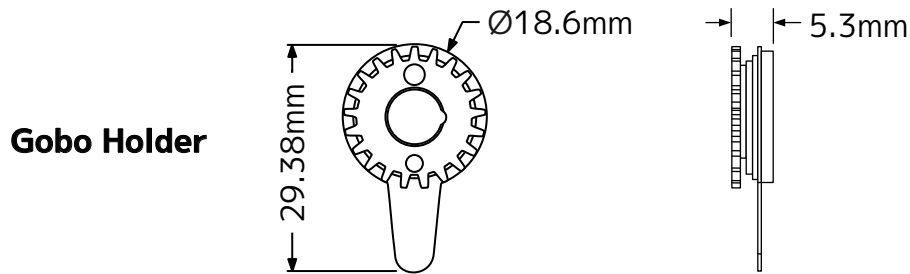
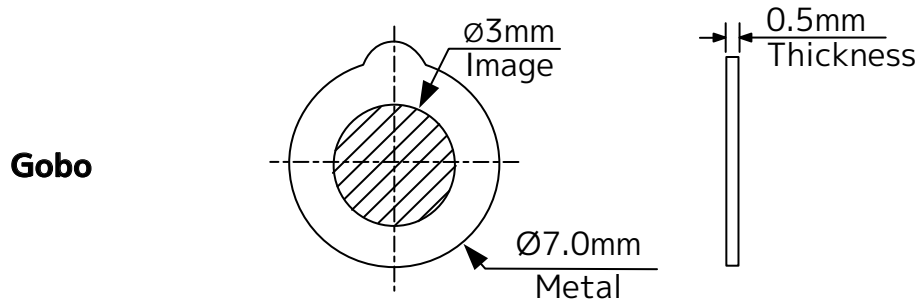

Please be aware of the intended position and correct sizing requirements of custom gobos.

**\*\*\* IMPORTANT NOTICE REGARDING CUSTOM GOBOS \*\*\***

Due to the high temperature optical system, special material is required for custom gobos. Due to varying manufacturing processes and tolerances, it is highly recommended to provide a gobo sample and holder from the fixture to the custom gobo vendor for accurate sizing. Extended testing of custom gobo designs is highly recommended prior to use. Contact ELATION SERVICE for further information.

**ELATION SERVICE USA -Monday -Friday 8:00am to 4:30pm PST**  
 323-582-3322 | support@elationlighting.com

**ELATION SERVICE EUROPE -Monday -Friday 08:30 to 17:00 CET**  
 +31 45 546 85 63 | support@elationlighting.eu

# GOBO INSTALLATION

## REPLACING A ROTATING GOBO



Custom Gobos can only be installed by technicians certified by Elation for LILI systems. This document outlines specifications for custom gobo design.

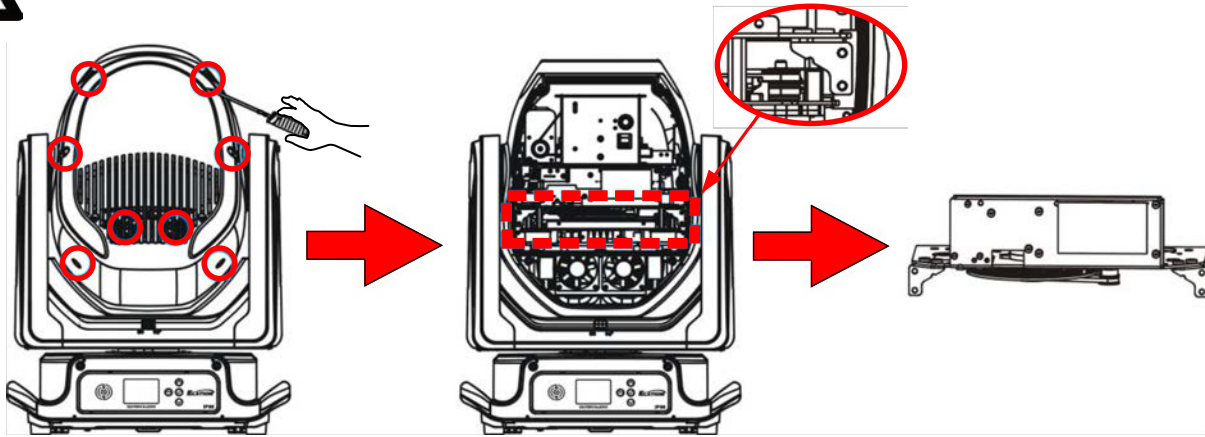

Place the fixture on a firm flat surface. Locate the (6x) screws on the side of the moving head and remove them. With the panel set aside, locate the Pattern Bracket Assembly and remove the (4x) screws that secure it to the internal housing frame.

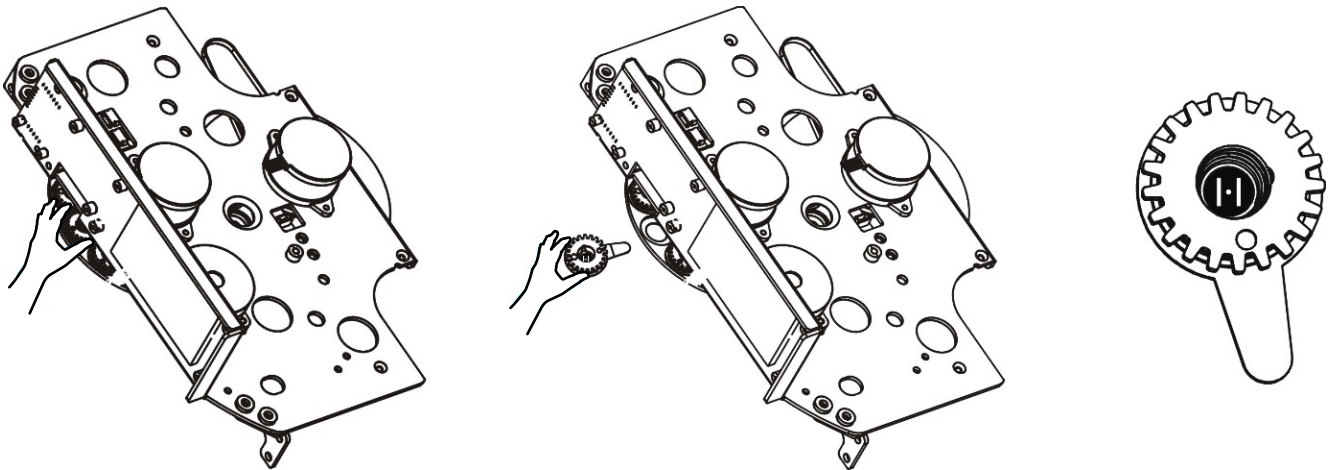

Locate the specific Rotating Gobo to replace. Carefully grip the Gobo using your thumb and index finger, gently lift it slightly, and then pull it out and away until it fully clears the Gobo Wheel.

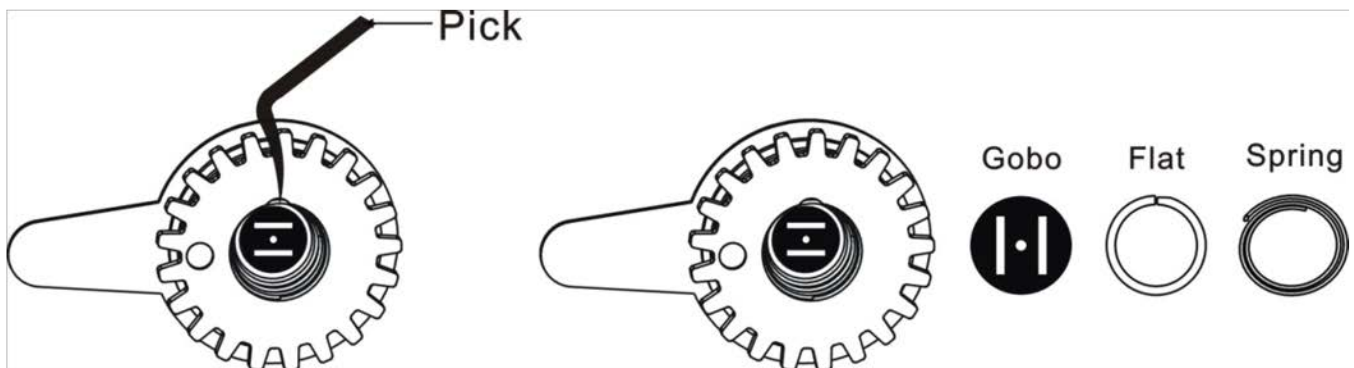

Locate the tab of the spring, and with a precision pick (or similar tool), carefully press the retaining spring inward to relieve the tension. Remove the retaining spring and carefully separate the Gobo from the Gobo Holder. Lastly, remove the flat washer attached to the removed Gobo and attach it to the desired replacement Gobo. Install the replacement Rotating Gobo following the steps above in reverse order.

# TORQUE SETTINGS FOR SCREWS



PANEL SCREWS MUST BE TIGHTENED WITH A TORQUE WRENCH ACCORDING TO THE TORQUE SPECIFICATION DESCRIBED BELOW.



CAUTION! DO NOT OVER TORQUE SCREWS AS THIS CAN CAUSE LEAKAGE ISSUES! TO CONFIRM THE IP66 INTEGRITY AFTER A PROCEDURE REQUIRING DISASSEMBLY/REASSEMBLY, TEST THE FIXTURE USING THE IP TESTER. CONTACT ELATION SERVICE FOR MORE DETAILS.



CAUTION! THE USE OF PROTECTIVE GLOVES AND SAFETY GOGGLES IS STRONGLY RECOMMENDED WHILE PERFORMING THE IP PRESSURE TEST! AVOID PLACING YOUR FACE, EYES, HANDS, ETC IN CLOSE PROXIMITY TO THE FIXTURE'S LENS WHILE PERFORMING THE TEST!

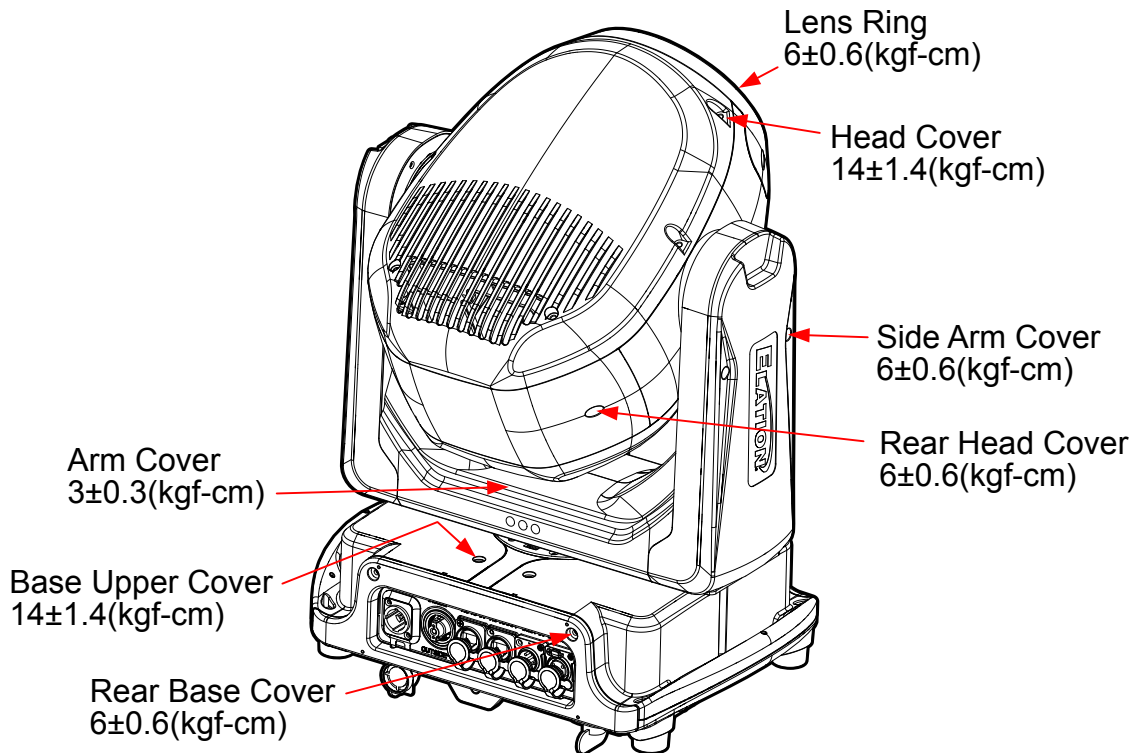

# IP TEST PARAMETERS

Following any repair or maintenance procedure that requires disassembly of the fixture, use Elation's IP Tester to confirm the IP integrity of the fixture. Please contact Elation Service for information regarding the Elation IP Tester, or visit the product information page online at: <https://www.elationlighting.com/ip-tester>



**CAUTION! THE USE OF PROTECTIVE GLOVES AND SAFETY GOGGLES IS STRONGLY RECOMMENDED WHILE PERFORMING THE IP PRESSURE TEST! AVOID PLACING YOUR FACE, EYES, HANDS, ETC IN PROXIMITY TO THE LENS OF THE FIXTURE WHILE PERFORMING THE TEST!**

**DE-HUMIDIFICATION:** IP66 fixtures operating in high-humidity environments may experience residual fogging or condensation. Such fogging will not affect the fixture, and can be removed using the following procedure: position the unit with the air valve pointing upwards, then open the air valve and run the unit for 1-2 hours after reaching operating temperature. Then, while the fixture is still hot, re-install the air valve and allow the unit to cool down. Please note: this procedure should be performed in a dry, climate-controlled environment. Avoid additional fogging by drying the fixture completely before placing into a road case.

Carefully remove Lens Collar and Rear Cover Plate as shown.

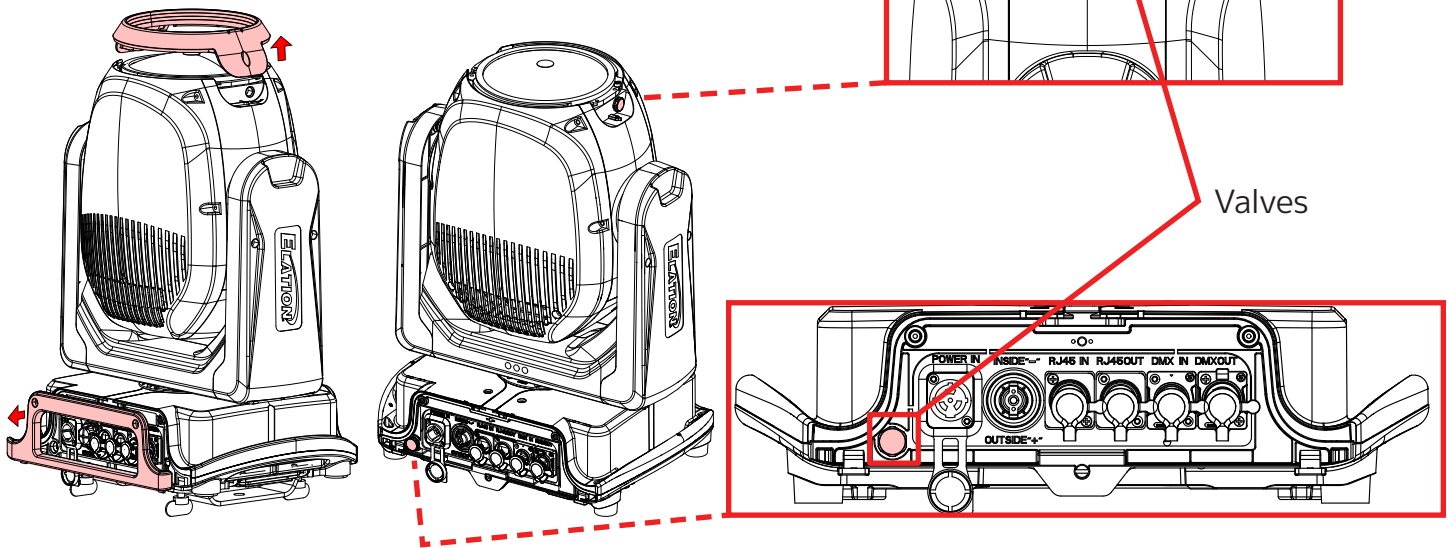

IP PRESSURE TESTING PARAMETERS			
Test Type	Low Pressure Limit	High Pressure Limit	Hold Time
Vacuum Test	-4.35psi (-30.00 KPa)	-5.08psi (-35.00 KPa)	10s
Pressure Test	3.62psi (25.00 KPa)	4.35psi (30.00 KPa)	10s



# INSTALLATION GUIDELINES



## **FLAMMABLE MATERIAL WARNING**

Keep fixture minimum 1.6 feet (0.5m) away from flammable materials and/or pyrotechnics.



## **ELECTRICAL CONNECTIONS**

A qualified electrician should be used for all electrical connections and/or installations.



**USE CAUTION WHEN POWER LINKING OTHER MODEL FIXTURES AS THE POWER CONSUMPTION OF OTHER MODEL FIXTURES MAY EXCEED THE MAX POWER OUTPUT ON THIS FIXTURE. CHECK SILK SCREEN FOR MAX AMPS.**



**MINIMUM DISTANCE TO LIGHTED OBJECTS MUST BE 65.6 FEET (20 METERS)  
MAXIMUM TEMPERATURE OF EXTERNAL SURFACE 167°F (75°C)  
DO NOT INSTALL THE FIXTURE IF YOU ARE NOT QUALIFIED TO DO SO!**

Fixture **MUST** be installed following all local, national, and country commercial electrical and construction codes and regulations.

Before rigging/mounting the fixture to any metal truss/structure or placing the fixture on any surface, a professional equipment installer **MUST** be consulted to determine if the metal truss/structure or surface is properly certified to safely hold the combined weight of the fixture, clamps, cables, and accessories.

Fixture ambient operating temperature range is **-4° to 113°F. (-20° to 45°C)**  
Do not use the fixture under or above this temperature.

Fixture should be installed in areas outside walking paths, seating areas, or away from areas where unauthorized personnel might reach the fixture by hand.

**NEVER** stand directly below the fixture when rigging, removing, or servicing. Overhead fixture installation must always be secured with a secondary safety attachment, such as an appropriately rated safety cable.

Allow approximately 10 minutes for the fixture to cool down before serving.

# INSTALLATION GUIDELINES

## OMEGA BRACKET WITH CLAMP INSTALLATION

When mounting the fixture to a truss, be sure to secure appropriately rated professional grade rigging clamps to the included Omega Brackets using an M10 or M12 screw fitted through the center hole of the Omega Brackets. **This fixture requires the installation of two Omega brackets and two clamps for secure truss mounting.**

Omega Brackets

Mount Truss Clamp to Omega Bracket with M10 or M12 screw fitted through the center hole of Omega Bracket.

The fixture also provides a built-in attachment point for a **SAFETY CABLE**. Be sure to only use the designated attachment point for the safety cable and never secure a safety cable to a carrying handle.

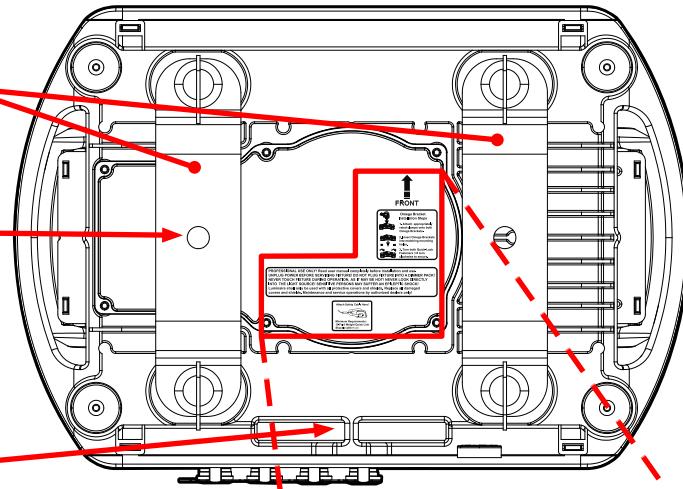

**ALWAYS ATTACH A SAFETY CABLE WHENEVER INSTALLING THIS FIXTURE IN A SUSPENDED ENVIRONMENT TO ENSURE THAT THE FIXTURE WILL NOT FALL IF THE CLAMP FAILS.**



**Omega Bracket Installation Steps**

1. Attach appropriately rated clamps onto both Omega Brackets.
2. Insert Omega Brackets into matching mounting holes.
3. Turn both Quick-Lock Fasteners 1/4 turn clockwise to secure.

**PROFESSIONAL USE ONLY!** Read user manual completely before installation and use. **UNPLUG POWER BEFORE SERVICING FIXTURE! DO NOT PLUG FIXTURE INTO A DIMMER PACK! NEVER TOUCH FIXTURE DURING OPERATION AS IT MAY BE HOT! NEVER LOOK DIRECTLY INTO THE LIGHT SOURCE! SENSITIVE PERSONS MAY SUFFER AN EPILEPTIC SHOCK!** Luminaire shall only be used with all protective covers and shields. Replace all damaged covers and shields. Maintenance and service operations by authorized dealers only!

Attach Safety Cable Here!

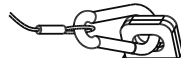

Minimum Requirements:  
12-Fold Weight Quick Link  
Shackle with Hook

## MOUNTING THE FIXTURE ON A TRUSS USING CLAMPS

When mounting the fixture to a truss, be sure to secure an appropriately rated professional grade rigging clamp to the bottom of the fixture using (2x) minimum grade 8.8 steel (2x) M12x25mm bolts fitted through the mounting hole of the Clamp. The fixture provides built-in rigging points for a **SAFETY CABLE** (not included). Be sure to only use one of the designated rigging points for the safety cable and never secure a safety cable to a carrying handle.

# INSTALLATION GUIDELINES

## RIGGING

Overhead rigging requires extensive experience, including amongst others calculating working load limits, installation material being used, and periodic safety inspection of all installation material and the fixture. If you lack these qualifications, do not attempt the installation yourself. Improper installation can result in bodily injury. Fixture is fully operational in the specific mounting positions illustrated below.

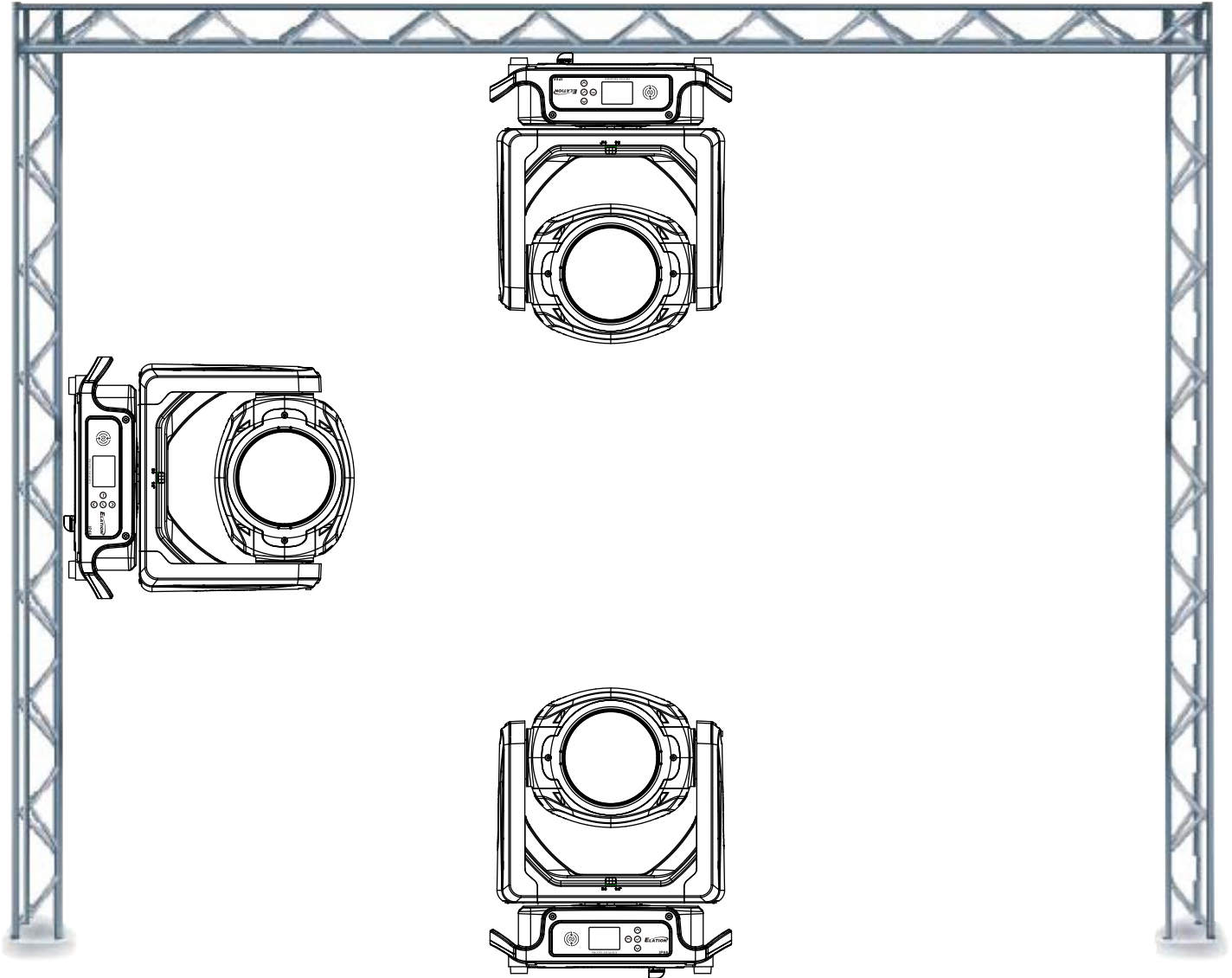

**FALLING FIXTURES CAN CAUSE SEVERE INJURY OR SERIOUS EQUIPMENT DAMAGE! FOR THIS REASON, FIXTURES SHOULD BE INSTALLED AND INSPECTED ONLY BY QUALIFIED PERSONNEL. DO NOT INSTALL THE UNIT IF YOU LACK THE QUALIFICATIONS TO DO SO, OR IF YOU HAVE DOUBTS ABOUT THE SAFETY AND SECURITY OF THE INSTALLATION SETUP OR LOCATION!**



**ALWAYS ATTACH A SAFETY CABLE WHENEVER INSTALLING THIS FIXTURE IN A SUSPENDED ENVIRONMENT TO ENSURE THE FIXTURE WILL NOT FALL IF THE CLAMP FAILS.**

# INSTALLATION GUIDELINES

## ART-NET | sACN CONNECTION

When connecting fixture to a network switch to control multiple devices, a Gigabit Ethernet Switch that supports IGMP (Internet Group Management Protocol) is required. Using a Gigabit Ethernet Switch that does not support IGMP can cause erratic behavior of all connected devices to the switch. Click link below for more information about IGMP.

[https://en.wikipedia.org/wiki/Internet\\_Group\\_Management\\_Protocol](https://en.wikipedia.org/wiki/Internet_Group_Management_Protocol)

## POWER AND DATA CABLES



**TO MAINTAIN THE IP66 RATING INTEGRITY OF THE FIXTURE, ALL CABLES MUST BE RUN TOWARDS THE GROUND TO PREVENT WATER ACCUMULATION AROUND THE CONNECTIONS.**

### SYSTEM MENU LCD DISPLAY

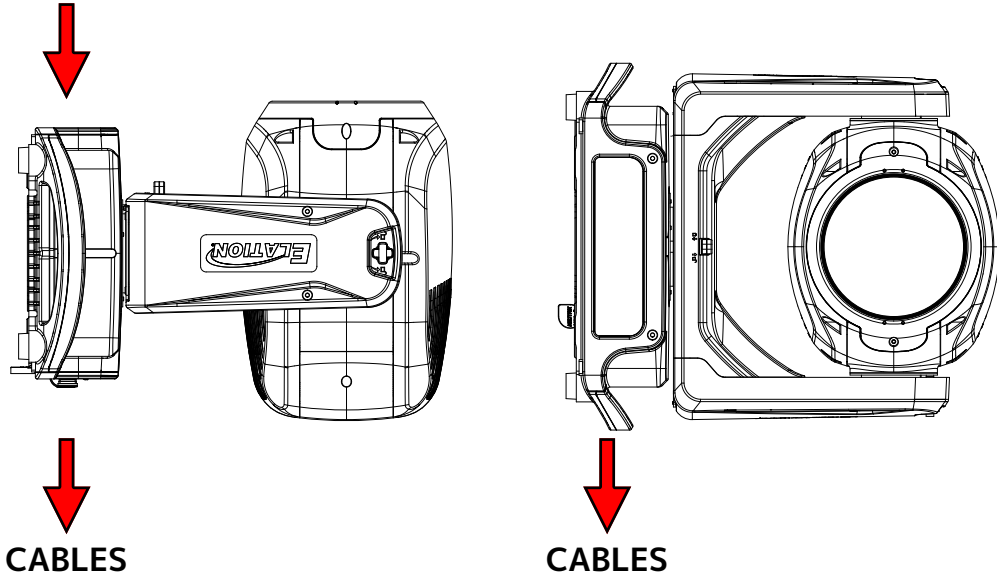

## RJ45 DATA CABLES



**THE INCLUDED RJ45 DATA CABLE IS FOR FIXTURE TO FIXTURE INTERCONNECTIONS ONLY! THE RJ45 CABLE CONNECTORS MAY NOT BE COMPATIBLE WITH OTHER RJ45 OR ETHERNET TYPE CONNECTORS.**

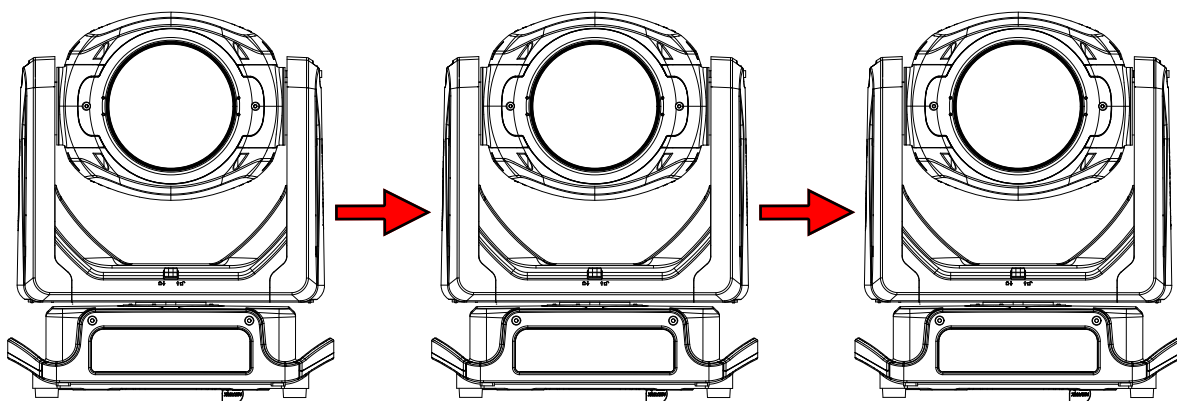

# INSTALLATION GUIDELINES

## POWER AND DATA CABLES



ENSURE ALL CONNECTIONS AND END-CAPS ARE PROPERLY SEALED WITH DIELECTRIC GREASE (AVAILABLE AT MOST ELECTRICAL SUPPLIERS) TO PREVENT WATER CORROSION AND/OR ELECTRICAL SHORT CIRCUIT.



TO MAINTAIN THE IP66 RATING INTEGRITY OF THE FIXTURE AND PREVENT WATER FROM ENTERING THE FIXTURE, SEAL ALL UNUSED CONNECTION RUBBER CAPS.

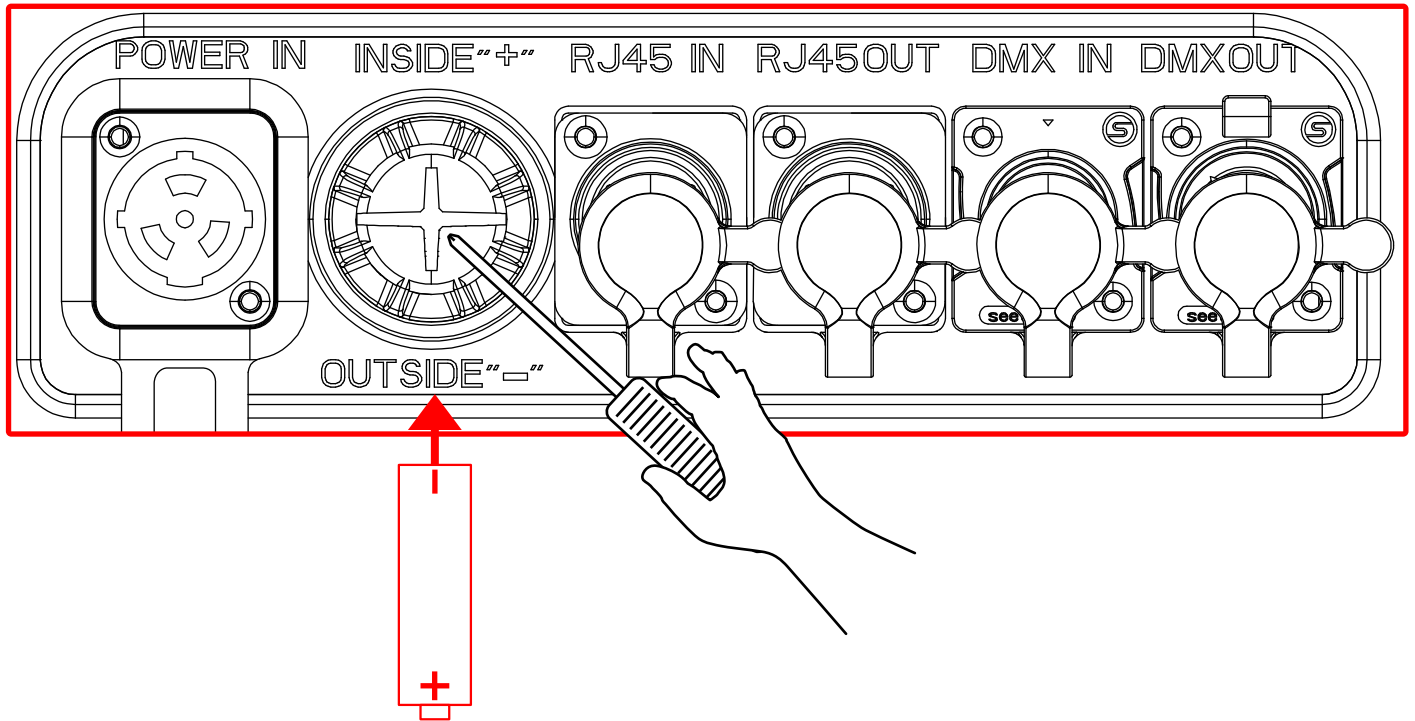

## BATTERY REPLACEMENT



Installing the battery incorrectly, in the wrong orientation, where the Plus (+) is inside and Negative (-) is outside, will lead to internal electronics and battery damage. A qualified electrician should be used for all electrical connections and/or installations.

1. Loosen the screw cap for the battery compartment.
2. Remove old battery and replace (**inside "-"**, and **outside "+"**).

**NOTE:** Replace the battery only with an Li-ion battery (IRC14500/700mAh), which can be ordered from the Elation Parts Website <https://parts.elationlighting.com>. Replace and tighten screw cap for the battery compartment.

# INSTALLATION GUIDELINES

## POTENTIAL INTERNAL FIXTURE DAMAGE FROM EXTERNAL SOURCES OF LIGHT BEAMS

External sources of light beams from direct sunlight, lighting and moving head fixtures, and lasers, which are focused directly towards the exterior housing and/or penetrate the front lens opening of Elation lighting fixtures, can cause severe internal damage including burning of optics, dichroic color filters, glass and metal gobos, prisms, animation wheels, frost filters, iris, shutters, motors, belts, wiring, discharge lamps, and LEDs.

This issue is not specific only to Elation lighting fixtures, but rather it is a common issue with lighting fixtures from all manufacturers. Although there is no true way to fully prevent this issue from happening, the guidelines below can reduce the risk of potential damage. Contact Elation Service for more details.

**DO NOT EXPOSE THE FIXTURE AND/OR FRONT LENS OPENING TO LIGHT BEAMS FROM DIRECT SUNLIGHT, OTHER LIGHTING OR MOVING HEAD FIXTURES, AND LASERS DURING UNPACKING, INSTALLATION, USE, AND EXTENDED IDLE TIMES OUTDOORS. DO NOT FOCUS A LIGHT BEAM FROM ONE LIGHTING FIXTURE DIRECTLY TOWARDS ANOTHER.**

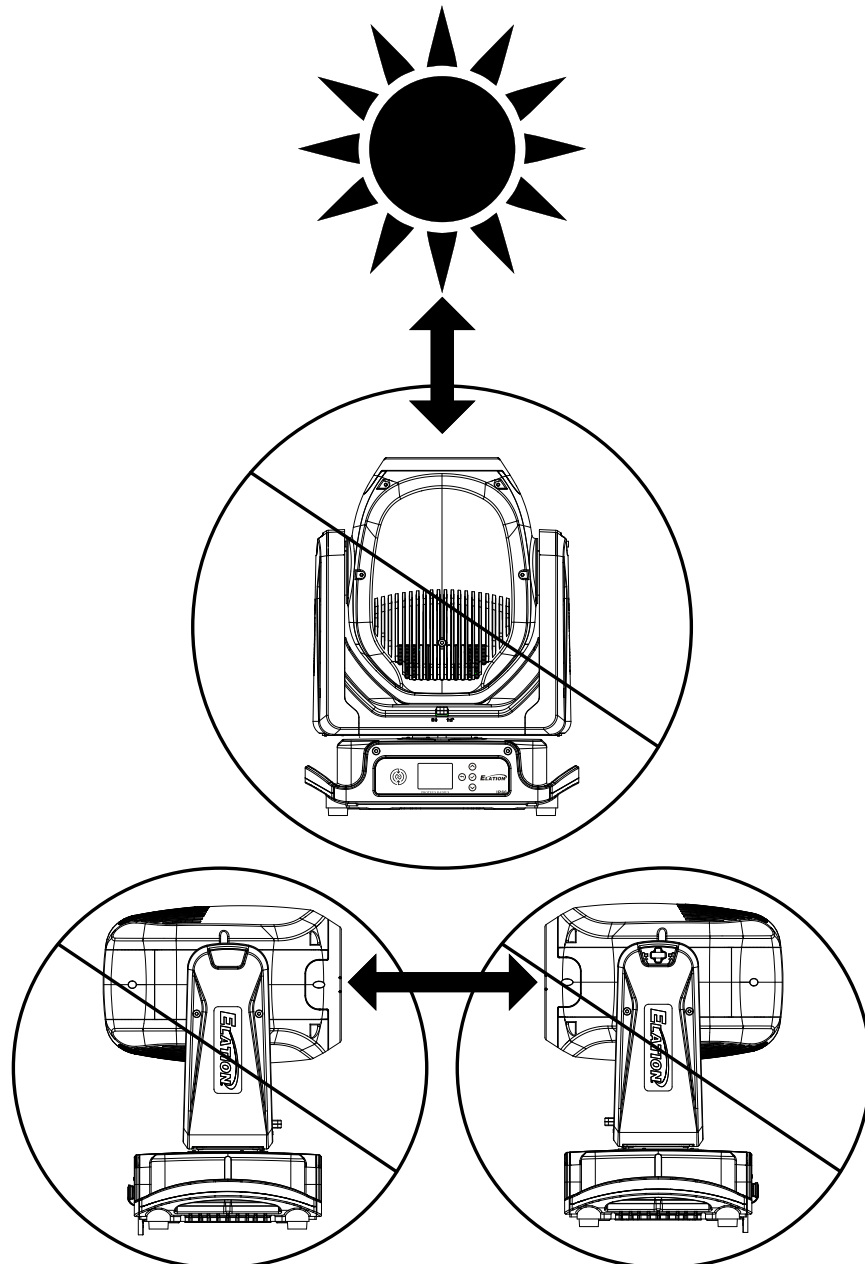

# SUN PROTECTION MODE

The fixture incorporates an automatic protection from harmful sunlight, which can damage a fixture's internal components from extended exposure. Fixtures use an internal sensor to determine their physical orientation, then reorient the fixture towards the ground to prevent sunlight from entering the lens.

This automatic feature only works when the fixture is powered. If the fixture is unpowered during setup, it is necessary to manually reorient the lenses away from the sun, and aim them towards the ground. Even a few minutes of sun exposure can cause damage inside the fixture.

The Sun Protection setting is accessed via the "No DMX Status" menu.

The automatic sun protection positioning is activated under the following conditions:

1. Power on without DMX signal: the fixture always starts in sun protection mode.
2. No DMX Status "Sun Protection": the fixture enters sun protection mode after approximately 3 minutes.
3. Remote DMX control: the sun protection position can be **temporarily** activated from the lighting console without the need to create a custom position preset. The fixture senses the correct ground orientation. This means that fixtures already facing the ground may not move their heads.

Hold "Sun Protect Position" for 3s to set the fixture to the sun protection position.

Sun protection status displays as "**Sun Protection: Active**".

The sun protection position deactivates under the following conditions:

1. Connect DMX signal.
2. Remote DMX control: Hold "Sun Protection Off" for 3s.

To avoid harsh or jarring movements, the sun protection position always uses a 5-second fade time when it is activated or deactivated.

# HIBERNATION MODE

To reduce wear on the fixture and its components, this mode disables motors and most electronics. Set the hibernation mode countdown time in the Display Menu: "Status Settings / Personality / Hibernation". Hibernation can be fully disabled.

The hibernation mode activates under the following conditions:

1. Loss of DMX: the fixture enters hibernation after the timeout expires. Default is 15 minutes.
2. Remote DMX control: Hold "Hibernate Fixture" for 3s

The hibernation mode deactivates under the following conditions:

1. Connect DMX Signal
2. Remote DMX control: Hold "Hibernate Off" for 3s

The fixture will perform a full calibration cycle, then assume the current DMX status.

Please note that the Hibernation does not change the PT position of the fixtures, allowing the user to set the desired position and then issue the Hibernate command.

To ensure the fixture is protected from harmful sunrays it is recommended to either leave the "No DMX Status" in "Sun Protection" (so the fixture is already in the correct position after 3 minutes of DMX loss) or set the fixture to a safe Tilt position manually first before hibernation.

**Burn and heat damage to the fixture's interior components due to external light sources (sun or other fixtures shining into the lens) is never covered under the manufacturers warranty.**

# FAN MODES and LOW NOISE OPERATION

The Proteus Radius is a high-performance fixture suited for multiple applications. For noise critical environments such as Theater, Opera or Orchestra Halls, it offers various fan operation modes which remove any distraction for the audience and performers. Fan Modes can be changed remotely via the DMX control channel, allowing the fixture to offer high output or whisper silent operation at a moment's notice. All Fan Modes smoothly transition over a brief time, preventing unwanted attraction to the fixture.

**Auto (Default)**—Fans only run at the speeds needed to keep the light source within a safe temperature range and ensures optimal performance of the fixture. If possible, they will turn-off, for example, when the fixture is dimmed to a low intensity. Fans sense the ambient and fixture temperature, and will always try to keep noise levels to a minimum. The fixture output will only reduce when the light source cannot be cooled down to its safe operating range due to high ambient temperature.

**NOTE: Recommended for daily operation.**

**High**—Fan speeds are increased throughout for the most efficient cooling of the fixture. This mode will increase wear on the fans and should only be utilized in exceptional circumstances. Fans will always run, even if the fixture is dimmed down. Fixture output is kept at 100% unless the light source temperature reaches an unsafe temperature at which point the fixture will reduce power carefully to ensure continued safe operation. This mode is only required in very high ambient temperatures when automatic fan speed adjustments are not desired.

## Low Noise Modes

For very critical noise environments, the fixture offers two additional Low Noise Modes for silent operation. The fixture output will be reduced, yet due to the extremely high luminous flux, the fixture still offers outstanding performance. In Low Noise Modes, all parameters of the fixture operate more quietly with reduced fan speeds.

**Low/Studio** - 75-80% max output, fans run at low speed.

**Mute** - All but one fixture fan is turned off for whisper-quiet operation. The fixture light output is reduced to 25%.

# SKY MOTION

## INTRODUCTION

Sky Motion is an innovative feature of the Proteus Radius which allows a fixture or group of fixtures to operate as a search light effect without the need for a dedicated lighting controller. Multiple fixtures can be interconnected, and with the simple assignment of IDs the fixture provides immediate access to a variety of search light effects that are easily adjustable in size, speed, and color.

Comparable in output to large 2000W or 4000W Xenon fixtures, the Proteus Radius operates at a fraction of the power, supports a wide range of 100V-240V power sources, has a much smaller footprint, lower weight, and is fully IP66 rated.

## SETUP

Sky Motion is designed to accommodate up to four unique fixture IDs. Fixtures with the same ID will always be at an identical position and have the exact shape, speed, and size. One fixture in the system must be set to the ID "MAIN", which provides all control signals and movement synchronization. Use ID "1" for other fixtures if needed.

For a traditional searchlight system, place four Proteus Radius closely together in a 2x2 grid. **The fixtures require a minimum space of 10" (255mm) between the fixture bases to ensure that the heads do not come into contact while in motion.** All cable connections should face inwards, and all displays should face outwards.

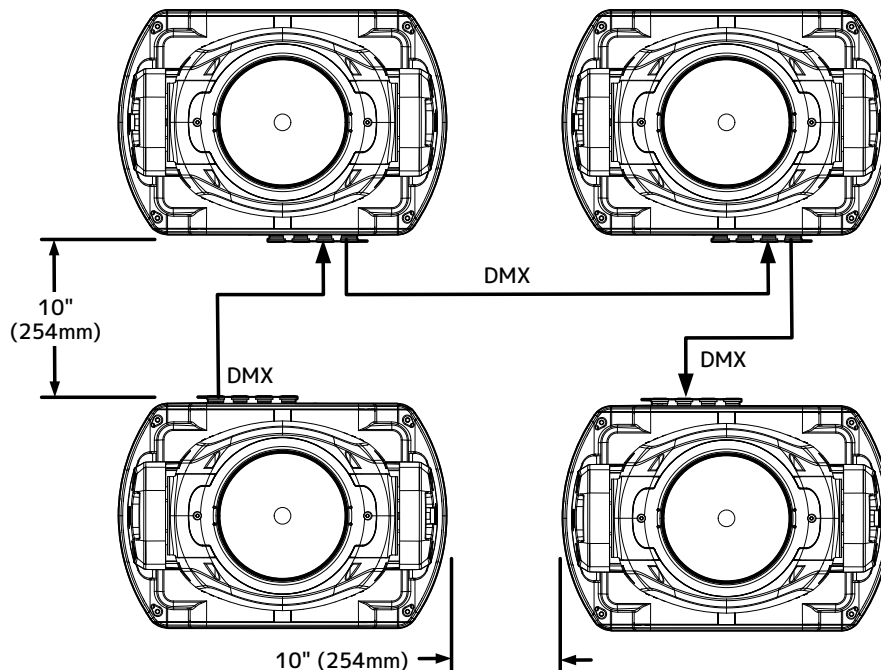

1. Connect fixtures to a suitable grounded power source.
2. Link fixtures via IP66-rated 5-pin DMX cables. Connect "DMX Out" from MAIN fixture to "DMX In" of the next. Cable order doesn't affect operation. **Do NOT connect the last fixture back to MAIN fixture.** Maximum combined cable length: 330 ft (100m).
3. Power on fixtures, wait for calibration cycle.
4. Enter System Menu: Hold "ENTER" 10sec. In menu, navigate to "Sky Motion," press "Enter."
5. Enable Sky Motion: On screen, select "Mode," press "ENTER," set to "ON." Confirm by pressing "ENTER" again.
6. Set fixture ID: One fixture as "MAIN." For easy access, choose a nearby fixture; all adjustments are done on MAIN.
7. Set IDs for other fixtures clockwise: 2, 3, and 4. Consider labeling IDs for clarity. IDs also display on Proteus Hybrid Max. Repeat IDs 1-4 as needed.
8. After setting fixture ID, exit Menu using "BACK." Dedicated Sky Motion home screen appears. Fixtures move in sync.

# SKY MOTION

## OPERATION

All settings are configured from the MAIN fixture. The display screens on the other fixtures show the ID and settings, but all control via the screens is disabled. The Sky Motion system is controlled by this simple display screen:

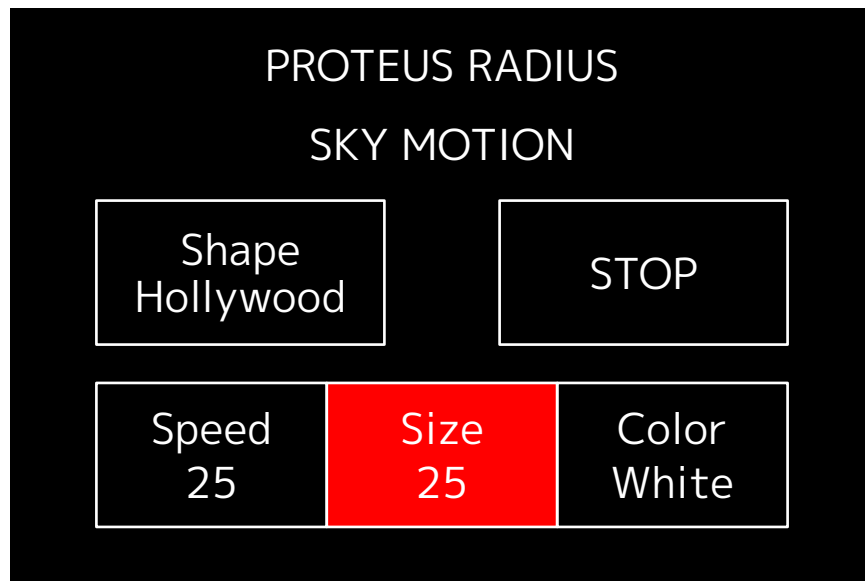

If the screen is locked, hold "ENTER" for 10 sec until the countdown is completed. Select one of the available shapes in the top left box. Use the arrow keys to navigate, noting that the current selection is indicated by the red highlighting, then press "ENTER" to select. Use the Up/Down arrows to browse the shapes and preview the results.

The most commonly used selection is "Hollywood", which emulates the traditional Xenon Searchlight movement found at movie premiers and special events.

The following unique shapes are available:

After the desired shape has been selected, the speed and size can be adjusted using the arrows and "ENTER" key. Observe the motion of the fixture to confirm that you are satisfied with the range and speed. Always press "ENTER" to confirm the changed value.

In addition to the Shape, Size, and Speed, it is also possible to select a color for the fixtures. 16 color choices are available, plus random color chases and color scrolls. Simply use the arrows to adjust, then confirm with "ENTER". Set the fixture back to White or any other color to stop the color changes.

# SYSTEM MENU

The fixture includes an easy to navigate system menu. The control panel (see image below) located on the front of the fixture, provides access to the main system menu and is where all necessary system adjustments are made to the fixture. During normal operation, pressing **ENTER** button once will access the fixture's main menu. Once in the main menu you can navigate through the different functions and access the submenus with the **UP** and **DOWN** buttons. Once you reach a field that requires adjusting, press the **ENTER** button to activate that field and use the UP and **DOWN** buttons to adjust the field. Pressing the **ENTER** button once more will confirm your setting. You may exit the main menu at any time without making any adjustments by pressing the **ENTER** button.

## Display Shortcuts:

**Power Off:** Long press the **ENTER** button for 3s, activate battery mode

**Power On:** Long press the **ENTER** button for 10s, unlock display, show 10s countdown

Long press the **UP** button and the **DOWN** button for 3s, disable Pan Tilt

Long press the **BACK** button and the **ENTER** button for 5s, Countdown 10 sec or Reset to Default

**NOTE:** To access the LCD Menu Control Display via the internal battery, press and hold the **MODE/ESC** button for 10 seconds. The LCD Menu Control Display will shut **OFF** automatically about 1 minute from the last button press.

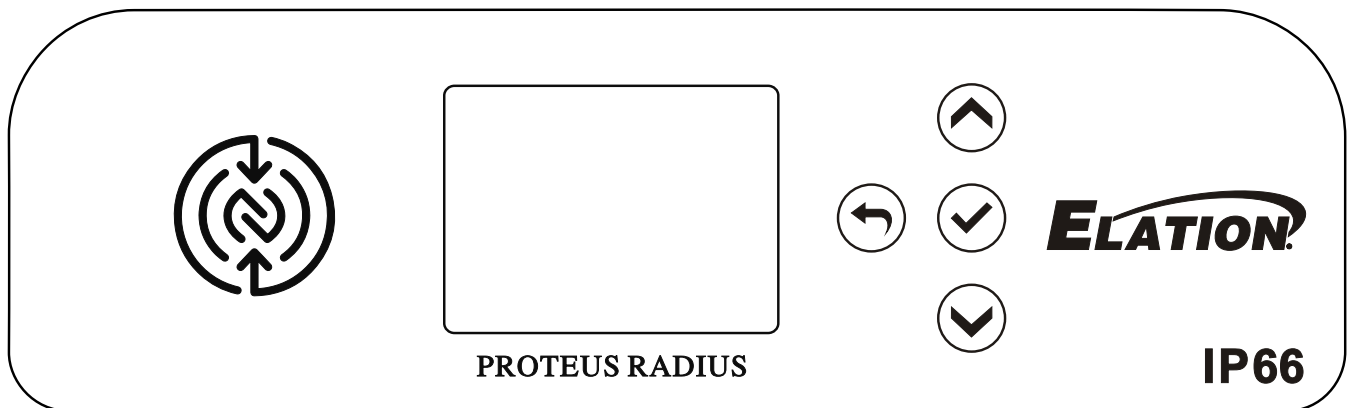

## BATTERY

This unit features a dedicated battery that can be used to power the screen display. This allows the user to configure the device's channel mode, DMX address, or any other screen-accessible features without needing to power on the device or even connect it to a power source. To activate the display on battery power, press and hold the **ENTER** button for 3 seconds.

**ALTHOUGH ARIA SETTINGS MAY APPEAR IN THE SYSTEM MENU, THIS FEATURE IS NOT ACTIVATED. ARIA WIRELESS DMX IS AN OPTIONAL FEATURE WHICH MUST BE ACTIVATED IN THE SERVICE MENU. PLEASE CONTACT ELATION SERVICE FOR FURTHER DETAILS.**



**AN ELATION E-LOADER III CAN BE USED TO UPDATE THE FIXTURE TO THE LATEST SOFTWARE. SEE SOFTWARE UPDATES SECTION FOR INSTRUCTIONS. TO ORDER THIS DEVICE, PLEASE CONTACT ELATION SUPPORT FOR FURTHER DETAILS.**

**ELATION SERVICE USA - Monday - Friday 8:00am to 4:30pm PST  
323-582-3322 | support@elationlighting.com**

**ELATION SERVICE EUROPE - Monday - Friday 08:30 to 17:00 CET  
+31 45 546 85 63 | support@elationlighting.eu**

# SYSTEM MENU

MAIN MENU		OPTIONS / VALUES (Default Settings in <b>BOLD</b> )	
DMX Settings	DMX Address	<b>001</b> - 512	
	DMX Mode	Standard	
	No DMX Status	<b>Hold Last</b>	
		Fade to Black	
Sun Protection			
Standalone	Manual Control	Dimmer 0% - <b>100%</b>	
		Pan	
		Tilt	
		...	
Settings	Status	Pan Invert	ON/OFF
		Tilt Invert	ON/OFF
		Pan Tilt Speed	<b>Normal</b> /Slow
		Pan Tilt Brake	Smooth/ <b>Fast</b>
		Pan Degree	<b>540</b> /630
		Tilt Degree	<b>270</b> /540
		CMY Speed	Normal/ <b>Fast</b>
		Hibernation	OFF, 1-99M ( <b>Default = 15 Min</b> )
	Fan Control	Auto	
		High	
		Silent	
		Studio	
		Mute	
	Protocol	Select Signal	DMX / Art-Net / sACN
		Universe	1
		DHCP	ON/OFF
		IP Address	
		Subnet Mask	
	Aria	IP DMX Out	On/Off
		Aria Enable	ON/OFF
	Dimmer Curve	Set Aria Channel	<b>0</b> -14
		Linear	
		Square	
	Reset	Square Inverse	
		<b>S-Curve</b>	
		All	
		Pan Tilt	
		Color	
		Gobo	
	Display	Focus	
		Others	
		Screen Delay	10s - 5min (Default = <b>1 min</b> )
	Service	Screen Lock	<b>Off</b> /ON
Rotate Display		<b>No</b> / Yes / Auto	
Factory Restore	Passcode	(Passcode = 050)	
	Calibration	Dimmer	
		Pan	
		Tilt	
	Factory Restore	Yes / <b>No</b>	

# SYSTEM MENU

MAIN MENU	OPTIONS / VALUES (Default Settings in <b>BOLD</b> )		
<b>Information</b>	Time	Current Time	
		Total Run Time	
		Last Run Time	
		Last Run Password	
		Clear Last Run	On/Off
		Clear Lamp Time	On/Off
	Temperature	Head	
		Base	
		Lamp	
	Humidity	Head	
		Base	
	Fan	1UBase_Fan1:	
		...	
	DMX Values	Pan	
		Tilt	
		...	
	Product IDs	RDM UID	
	Error Logs	Fixture Errors	
		Reset Error Log	Yes / <b>No</b> (Passcode = 050)
	Software Version	Vx.x	

# SYSTEM MENU

## FUNCTION - Auto Program

Define fixture mode (**Primary** or **Alone**) for running Auto Programs. Select desired internal programs under "**Select Program**", set the number of steps under "**Edit program**", and edit individual scenes under "**Edit Scenes**".

## PERSONALITY - Status Settings - Address Via DMX

When ON, define the desired DMX address via an external controller.

**NOTE: This process assumes the fixture DMX address is set to 001. If fixture DMX address is not at 001, you must adjust the channel numbers accordingly in order for this feature to work.**

**For example: if your fixture address is 010, then Channel 1 becomes Channel 10, Channel 2 becomes Channel 11, and Channel 3 becomes Channel 12.**

1. Connect the fixture to the external controller and power ON.
2. Set the DMX value of **Channel 1** on the controller to (7).
3. Set the DMX value of **Channel 2** on the controller to (7) or (8). When set to (7), the DMX address can be set between (1) and (255). When set to (8), the DMX address can be set between (256) and (511).
4. Using **Channel 3** on the controller set the desired DMX address of the fixture.  
**Example 1:** If the desired DMX address is 57, set **Channel 1** to a value of (7), set **Channel 2** to a value of (7), and then set **Channel 3** to a value of (57).  
**Example 2:** If the desired DMX address is 420, set **Channel 1** to a value of (7), set **Channel 2** to a value of (8), and then set **Channel 3** to a value of (164). (256+164=420)
5. After setting **Channel 3** to the desired DMX address value, wait approximately 20 seconds for the fixture to complete the address reset function.

## PERSONALITY - Service Settings - Password (050)

**NOTE:** The Service Password MUST be entered in order to access the following menus:

### Clear Err. Info

### PERSONALITY - Display Setting - Key Lock

When ON, Control Panel buttons lock automatically after exiting main menu for 15 seconds. To unlock, keep **MODE/ESC** button pressed for 3 seconds.

### PERSONALITY - Dimmer Curve

Select dimming curve (Linear, Square, InverseSquare, S-Curve).

### PERSONALITY - Reset Default (011)



**ONLY QUALIFIED TECHNICIANS SHOULD PERFORM THIS FUNCTION!**

**NOTE: SAVED WHITE BALANCE IS ERASED AFTER A RESET IS PERFORMED!**

This function restores all fixture settings to the factory default settings. The password is **011** and must be entered each time a reset is performed.

### EFFECT ADJUST - Test Channel

Auto test each individual channel function independently from the DMX control board.

### EFFECT ADJUST - Manual Control

Select and manually test and fine adjust each individual channel function Independently from DMX control board. This function will center TILT motors and set dimmer to 100%. TILT functions will still operate if the fixture needs to be positioned to a flat clear surface. With the individual functions, you can focus the light on a flat surface (wall) and perform fine adjustments.

# SYSTEM MENU

## EFFECT ADJUST - Calibration



**ONLY QUALIFIED TECHNICIANS SHOULD PERFORM THIS FUNCTION.**

This function allows small adjustments to be made to the Tilt and Zoom movements to compensate for wear or in the event a sensor has been knocked slightly out of place. Because improper use of this function can result in undesired operation this function has been password protected. The password is **050** and must be entered each time the calibration menu function is entered. Because calibration is an extremely delicate procedure, instructions on performing this action are left out of this manual. For a first-time calibrator, please contact our customer support team for step-by-step instructions.

## EDIT PROGRAM - Rec. Controller

The fixture features an integrated DMX-recorder by which you can transmit the programmed scenes from your DMX-controller to the moving head. Adjust the desired scene numbers via the encoder (from – to). When you call up the scenes at your controller, they will automatically be transmitted to the moving head.

### EDIT PROGRAM Record Controller Working With Built In Programs

A Master unit can send up to 3 different data groups to the Secondary units, i.e. a Master unit can start 3 different Secondary units, which run 3 different programs. The Master unit sends the 3 program parts in a continuous loop.

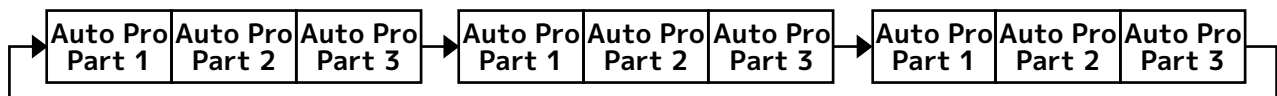

The Secondary unit receives data from the Master unit according to the group which the Secondary unit was assigned to. If e.g. a Secondary unit is set to **“Secondary 1”** in the menu **“Set to Secondary”**, the Primary unit sends **“Auto Program Part 1”** to the Secondary unit. If set to **“Secondary 2”**, the Secondary unit receives **“Auto Program Part 2”**.

To start an Auto Program proceed as follows:

### 1. Secondary Setting

- Select **“Function Mode”**.
- Press **ENTER** to confirm.
- Select **“Set to Secondary”**.
- Press **ENTER** to confirm.
- Select **“Secondary 1”**, **“Secondary 2”** or **“Secondary 3”**.
- Press **ENTER** to confirm.
- Press **MODE/ESC** in order to return to the main menu.

### 2. Automatic Program Run

- Select **“Function Mode”**.
- Press **ENTER** to confirm.
- Select **“Auto Program”**.
- Press **ENTER** to confirm.
- Select **“Primary”** or **“Alone”**.
- Press **ENTER** to confirm.
- Press **MODE/ESC** in order to return to the main menu.

# SYSTEM MENU

## 3. Program Selection for Auto Pro Part

- Select "Edit Program".
- Press **ENTER** to confirm.
- Select "Select Programs".
- Press **ENTER** to confirm.
- Select "Auto Pro Part 1", "Auto Pro Part 2" or "Auto Pro Part 3", and select which Secondary program is to be sent. Selection "Part 1" means, that the Secondary unit runs the same program as the master units.
- Press **ENTER** to confirm.
- Press **MODE/ESC** to return to the main menu.

## 4. Program Selection for Edit Program

- Select "Edit Program".
- Press **ENTER** to confirm.
- Select "Edit Program".
- Press **ENTER** to confirm.
- Select the desired program to edit specific scenes into a specific program.
- Press **ENTER** to confirm.
- Press **MODE/ESC** in order to return to the main menu.

## 5. Automatic Scene Recording

- Select "Edit Program".
- Press **ENTER** to confirm.
- Select "Edit Scenes".
- Press **ENTER** to confirm.
- Select desired scene numbers. A maximum of 250 scenes can be programmed.
- Press **ENTER** to confirm.
- Press **MODE/ESC** in order to return to the main menu.

### Example:

Program 2 includes scenes: 10, 11, 12, & 13 Program 4 includes scenes: 8, 9, & 10 Program 6 includes scenes: 12, 13, 14, & 15 Auto Pro Part 1 is Program 2

Auto Pro Part 2 is Program 3

Auto Pro Part 3 is Program 6

The 3 Secondary groups run the Auto Program in certain time segments. (See diagram below)

### Part 1:

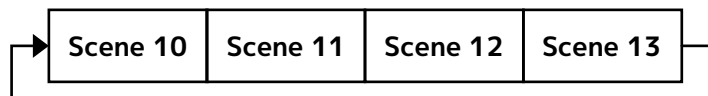

### Part 2:

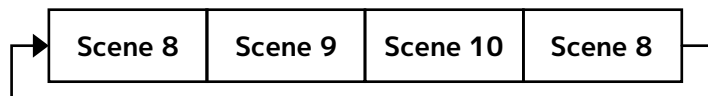

### Part 3:

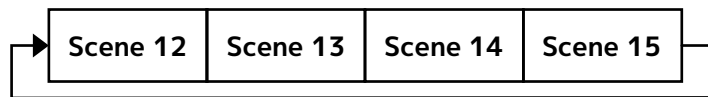

# DIMMER MODES AND DIMMER CURVES

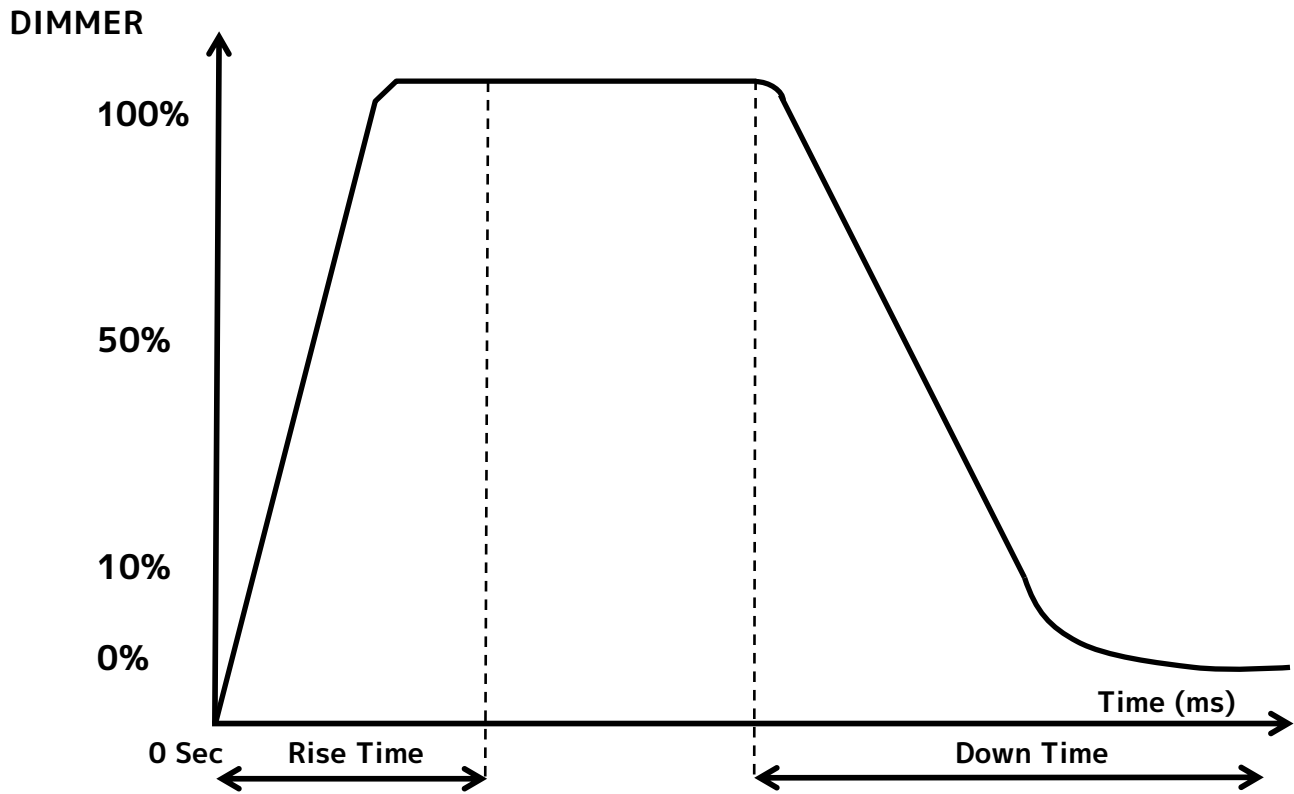

Dimming Curve Ramp Effect	0 sec Fade Time		1 sec Fade Time	
	Rise Time (ms)	Down Time (ms)	Rise Time (ms)	Down Time (ms)
Standard (default)	0	0	0	0
Stage	780	1100	1540	1660
TV	1180	1520	1860	1940
Architectural	1380	1730	2040	2120
Theatre	1580	1940	2230	2280
Stage 2	0	1100	0	1660

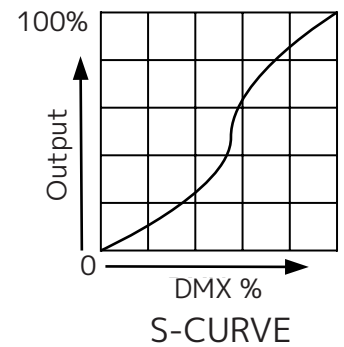
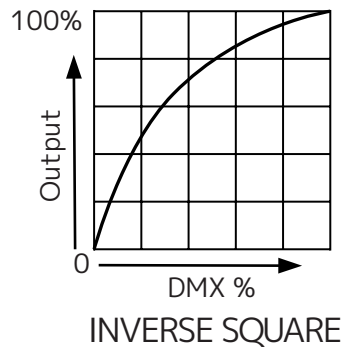
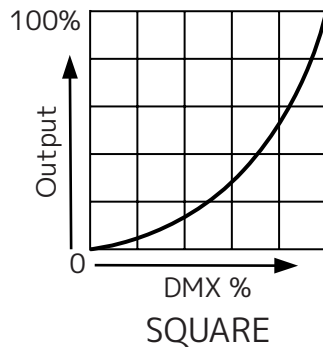
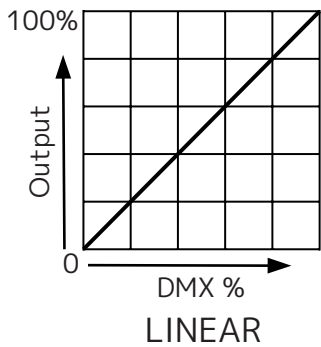

# DMX TRAITS

Standard	Extended	Value	Function	Snap	Default Value	
1	1	0-255	<b>PAN Movement 8bit:</b>		127	
			0-255			
2	2	0-255	<b>Pan Fine 16bit:</b>		127	
			0-255			
3	3	0-255	<b>TILT Movement 8bit:</b>		127	
			Tilt Movement			
4	4	0-255	<b>Tilt Fine 16bit:</b>		127	
			Fine control of Tilt movement			
5	5		<b>Pan Motor continuous rotation:</b>			
			0-63			stop rotation by spinout
			64-127			stop rotation by shortcut
			128-189			Forwards Pan rotation from fast to slow
			190-193			No rotation
194-255	Backwards Pan rotation from slow to fast					
6	6		<b>Tilt Motor continuous</b>			
			0-63			stop rotation by spinout
			64-127			stop rotation by shortcut
			128-189			Forwards Tilt rotation from fast to slow
			190-193			No rotation
194-255	Backwards Tilt rotation from slow to fast					
7	7	0-255	<b>Cyan:</b>			
			Cyan (0-100% Cyan)			
	8	0-255	<b>Cyan Fine:</b>			
			Cyan Fine			
8	9	0-255	<b>Magenta:</b>			
			Magenta (0-100% Magenta)			
	10	0-255	<b>Magenta Fine:</b>			
			Magenta Fine			
9	11	0-255	<b>Yellow:</b>			
			Yellow (0-100% Yellow)			
	12	0-255	<b>Yellow Fine:</b>			
			Yellow Fine			

# DMX TRAITS

Standard	Extended	Value	Function	Snap	Default Value
10	13		<b>Color Wheel:</b>		
		0-2	Open		
		3-7	C1		
		8-12	C2		
		13-17	C3		
		18-22	C4		
		23-27	C5		
		28-32	C6		
		33-37	C7		
		38-42	C8		
		43-47	C9		
		48-52	C10		
		53-57	C11		
		58-62	C12		
		63-67	C13		
		68-72	C14		
		73-77	C15		
		78-82	C16		
		83-87	C17		
		88-92	C18		
		93-97	C19		
		98-102	C20		
		103-107	C21		
		108-112	C22		
		113-117	C23		
118-122	C24				
123-127	C25				
		128-189	Clockwise effect from fast to slow		
		190-193	No rotation		
		194-255	Counter-clockwise effect from slow to fast		
	14	0-255	<b>Color Wheel Fine:</b>		
			Fine Control of Color Wheel position		

# DMX TRAITS

Standard	Extended	Value	Function	Snap	Default Value
11	15		<b>Rotating Gobo</b>		
		0-7	Open		
		8-14	Rot. gobo 1		
		15-21	Rot. gobo 2		
		22-28	Rot. gobo 3		
		29-35	Rot. gobo 4		
		36-42	Rot. gobo 5		
		43-49	Rot. gobo 6		
		50-56	Rot. Gobo 7		
		57-63	Rot. gobo 8		
		64-70	Rot. gobo 9		
		71-77	Rot. gobo 10		
		78-84	Rot. gobo 11		
		85-91	Rot. gobo 12		
		92-98	Rot. Gobo 13		
		99-105	Gobo 1 shake slow to fast		
		106-112	Gobo 2 shake slow to fast		
		113-119	Gobo 3 shake slow to fast		
		120-126	Gobo 4 shake slow to fast		
		127-133	Gobo 5 shake slow to fast		
		134-140	Gobo 6 shake slow to fast		
		141-147	Gobo 7 shake slow to fast		
		148-154	Gobo 8 shake slow to fast		
		155-161	Gobo 9 shake slow to fast		
		162-168	Gobo 10 shake slow to fast		
		169-175	Gobo 11 shake slow to fast		
176-182	Gobo 12 shake slow to fast				
183-189	Gobo 13 shake slow to fast				
190-221	Scroll CW fast to slow				
222-223	Stop				
224-255	Scroll CCW slow to fast				
12	16		<b>Rotating Gobo Index, Rotation</b>		
		0-127	Gobo indexing		
		128-189	Clockwise gobo scroll from fast to slow		
		190-193	No rotation		
194-255	Counter-clockwise gobo scroll from slow to fast				
13	17	0-255	<b>Rotating gobo fine indexing:</b>		
			Fine indexing		

# DMX TRAITS

Standard	Extended	Value	Function	Snap	Default Value		
14	18		<b>Fixed gobos1</b>				
		0-45	Open				
		46-48	Gobo 1				
		49-51	Gobo 2				
		52-54	Gobo 3				
		55-57	Gobo 4				
		58-60	Gobo 5				
		61-63	Gobo 6				
		64-66	Gobo 7				
		67-69	Gobo 8				
		70-72	Gobo 9				
		73-75	Gobo 10				
		76-78	Gobo 11				
		79-81	Gobo 12				
		82-84	Gobo 13				
		85-87	Gobo 14				
		88-90	Gobo 15				
		91-93	Gobo 16				
		94-96	Gobo 17				
		97-99	Gobo 18				
		100-102	Gobo 19				
		103-105	Gobo 20				
		106-108	Gobo 21				
		109-111	Gobo 22				
		112-114	Gobo 23				
		115-117	Gobo 24				
				118-120	Gobo 1 shake slow to fast		
				121-123	Gobo 2 shake slow to fast		
				124-126	Gobo 3 shake slow to fast		
				127-129	Gobo 4 shake slow to fast		
				130-132	Gobo 5 shake slow to fast		
				133-135	Gobo 6 shake slow to fast		
				136-138	Gobo 7 shake slow to fast		
				139-141	Gobo 8 shake slow to fast		
				142-144	Gobo 9 shake slow to fast		
				145-147	Gobo 10 shake slow to fast		
				148-150	Gobo 11 shake slow to fast		
				151-153	Gobo 12 shake slow to fast		
				154-156	Gobo 13 shake slow to fast		
				157-159	Gobo 14 shake slow to fast		
				160-162	Gobo 15 shake slow to fast		
		163-165	Gobo 16 shake slow to fast				
		166-168	Gobo 17 shake slow to fast				
		169-171	Gobo 18 shake slow to fast				
		172-174	Gobo 19 shake slow to fast				
		175-177	Gobo 20 shake slow to fast				
		178-180	Gobo 21 shake slow to fast				
		181-183	Gobo 22 shake slow to fast				
		184-186	Gobo 23 shake slow to fast				
		187-189	Gobo 24 shake slow to fast				
		190-221	Clockwise gobo scroll from fast to slow				
		222-223	No rotation				
		224-255	Counter-clockwise gobo scroll from slow to fast				

# DMX TRAITS

Standard	Extended	Value	Function	Snap	Default Value
	19	0-255	<b>Fixed gobo indexing Fine 1:</b> Fine indexing		
15	20	0-19	<b>Roating prism1、 2,Prism/Gobo macros:</b> Open		
		20-73	Prism1		
		74-127	Prism2		
		128-255	reserve		
16	21	0-127	<b>Rotating prism index,rotating gobo rotation1-2:</b> Prism indexing		
		128-189	Clockwise prism rotation from fast to slow		
		190-193	No rotation		
		194-255	Counter-clockwise prism rotation from slow to fast		
	22	0-255	<b>Rotating prism indexing Fine1-2:</b> Fine indexing		
17	23	0-19	<b>Roating prism,Prism3、 4/Gobo macros:</b> Open		
		20-73	Prism3		
		74-127	Prism4		
		128-255	reserve		
18	24	0-127	<b>Rotating prism index,rotating gobo rotation3-4:</b> Prism indexing		
		128-189	Clockwise prism rotation from fast to slow		
		190-193	No rotation		
		194-255	Counter-clockwise prism rotation from slow to fast		
	25	0-255	<b>Rotating prism indexing Fine3-4:</b> Fine indexing		
19	26	0-255	<b>Focus:</b> Focus adjustment from small to big		127
20	27	0-255	<b>Focus Fine:</b> Focus adjustment Fine		127
21	28	0-31	<b>Shutter, strobe:</b> Shutter closed		50
		32-63	No function (shutter open)		
		64-95	Strobe effect slow to fast		
		96-127	No function (shutter open)		
		128-159	Pulse-effect in sequences		
		160-191	No function (shutter open)		
		192-223	Random strobe effect slow to fast		
		224-255	No function (shutter open)		

# DMX TRAITS

Standard	Extended	Value	Function	Snap	Default Value
22	29	0-255	<b>Dimmer:</b>		
			Intensity 0 to 100%		
23	30	0-255	<b>Dimmer Fine:</b>		
			Dimmer fine		
24	31		<b>Dim Modes (changes menu setting permanently )</b>	0s	
		0-20	Standard		
		21-40	Stage		
		41-60	TV		
		61-80	Architectural		
		81-100	Theatre		
		101- 120	Stage 2		
			<b>Dimmer Delay Time</b>		
		121	0s		
		122	0.1s		
		123	0.2s		
		124	0.3s		
		125	0.4s		
		126	0.5s		
		127	0.6s		
		128	0.7s		
		129	0.8s		
		130	0.9s		
		131	1.0s		
		132	1.5s		
		133	2.0s		
		134	3.0s		
		135	4.0s		
		136	5.0s		
		137	6.0s		
		138	7.0s		
		139	8.0s		
140	9.0s				
141	10s				
142 - 255	Idle				
25	32		<b>Frost</b>		
		0-127	Open Frost1		
		128-255	Open Frost2		

# DMX TRAITS

Standard	Extended	Value	Function	Snap	Default Value
	33	0-255	<b>Speed Of CMY &amp; Colour macro Speed:</b> Speed Max →Min		
	34		<b>Colour macros - CMY and colour wheel:</b>		
		0-31	OFF		
		32-39	Macro1		
		40-47	Macro2		
		48-55	Macro3		
		56-63	Macro4		
		64-71	Macro5		
		72-79	Macro6		
		80-87	Macro7		
		88-95	Macro8		
		96-103	Macro9		
		104-111	Macro10		
		112-119	Macro11		
		120-127	Macro12		
		128-135	Macro13		
		136-143	Macro14		
		144-151	Macro15		
		152-159	Macro16		
		160-167	Macro17		
		168-175	Macro18		
		176-183	Macro19		
		184-191	Macro20		
		192-199	Macro21		
	200-207	Macro22			
	208-215	Macro23			
	216-223	Macro24			
	224-231	Macro25			
	232-239	Macro26			
	240-247	Macro27			
	248-255	Random CMY			
	35		<b>Pan / Tilt Speed:</b>		
		0-225	Max to min speed		
		226-235	Blackout by movement		
		236-245	Blackout by all wheel changing		
		246-255	No function		

# DMX TRAITS

Standard	Extended	Value	Function	Snap	Default Value
26	36	0-79	Normal		
		80-84	All motor reset		
		85-87	Scan motor reset		
		88-90	Color motor reset		
		91-93	Gobo motor reset		
		94-96	Zoom motor reset		
		97-99	Others motor reset		
		100-172	Idle		
		173-174	Hibernation Off		
		175-176	Hibernation		
		177-178	Home Position Before Power Off		
		179-180	Home Position Off		
		181-190	Pan Tilt Smooth (default)		
		191-200	Pan Tilt Fast		
		201-210	Dimmer Curve Linear (default)		
		211-220	Dimmer Curve Square		
		221-230	Dimmer Curve Inverse Square		
		231-240	Dimmer Curve S-Curve		
		241	Internal program 1		
		242	Internal program 2		
		243	Internal program 3		
		244	Internal program 4		
		245	Internal program 5		
		246	Internal program 6		
		247	Internal program 7		
		248-249	Idle		
		250-251	Display off		
		252-253	Display on		
254-255	Idle				

# REMOTE DEVICE MANAGEMENT (RDM)

**NOTE: In order for RDM to work properly, RDM enabled equipment must be used throughout the entire system, including DMX data splitters and wireless systems.**

Remote Device Management (RDM) is a protocol that sits on top of the DMX512 data standard for lighting, allowing the DMX systems of the fixtures to be modified and monitored remotely. This protocol is ideal for instances in which a unit is installed in a location that is not easily accessible.

With RDM, the DMX512 system becomes bi-directional, allowing a compatible RDM enabled controller to send out a signal to devices on the wire, as well as allowing the fixture to respond (known as a GET command). The controller can then use its SET command to modify settings that would typically have to be changed or viewed directly via the unit's display screen, including the DMX Address, DMX Channel Mode, and Temperature Sensors.

## FIXTURE RDM INFORMATION:

RDM Code	Device ID	Device Model ID	Personality ID
0x22A6	Open	0x71E	Standard Mode (1) Extended Mode (2)

**Please be aware that not all RDM devices support all RDM features,** and therefore it is important to check beforehand to ensure that the equipment that you are considering includes all of the features that you require.

The following parameters are accessible in RDM on this device:

[0x0200] Sensor Definition
[0x0201] Sensor Value
[0x0080] Device Model Description
[0x0081] Manufacturer Label
[0x0082] Device Label
[0x00E0] DMX Personality
[0x00E1] DMX Personality Description
[0x0400] Device Hours
[0x0600] Pan Invert
[0x0601] Tilt Invert
[0x0500] Display Invert

# ERROR CODES

When power is applied, the unit will automatically enter a “Reset/Test” mode. This mode brings all the internal motors to a home position. If there is an internal problem with one or more of the motors an error code will flash in the display in the form of “XXEr” where as XX will represent a function number. For example, when the display shows “0Er” it means there is some type of error with the Pan motor. If there are multiple errors during the start-up process they will all flash in the display. For example: if the fixtures has errors on Channel 1, 2, and 5 all at the same time, you will see the error message “01Er”, “02Er”, and “05Er” flash repeated 5 times.

If an error does occur during the initial start-up procedure the fixture will self-generate a second reset signal and try to realign all the motors and correct the errors. If the error persists after a second attempt a third attempt will be made. If after a third attempt all the errors have not been corrected the fixture will make the following determinations:

- 3 or More Errors: The fixture cannot function properly with three or more errors therefore the fixture will place itself in a stand-by mode until subsequent repairs can be made.
- Less Than 3 Errors: The fixture has less than 3 errors; therefore, most other functions will work properly. The fixture will attempt to operate normally until the errors can be correct by a technician. The errors in question will remain flashing in the display as a reminder of internal errors.

Note: Error Codes are subject to change without any prior written notice.	
ERROR CODES	DESCRIPTION
PAN Er	Movement is not located in the default position after the reset. This message will appear after a fixture reset if the magnetic-indexing circuit malfunctions (sensor failed, or magnet is missing) or there is a motor failure (defective motor or a defective motor IC drive on the main PCB). This error may also be displayed if the head/yoke was blocked during TILT Er a reset function.
TILT Er	
Cyan Color Er	Movement is not located in the default position after the reset. This message will appear after a fixture reset if the magnetic-indexing circuit malfunctions (sensor failed, or magnet is missing) or there is a motor failure (defective motor or a defective motor IC drive on the main PCB).
Magenta Color Er	
Yellow Color Er	
CTO Color Er	
Color Wheel Er	
Focus Er	
Zoom Er	
Iris Er	
Prism 1 Er	
Prism 2 Er	
Prism_Rot 1 Er	
Prism_Rot 2 Er	

# SOFTWARE UPDATES

## E-LOADER III



**ONLY QUALIFIED TECHNICIANS SHOULD PERFORM THIS FUNCTION!  
NOTE ALL MENU SETTINGS BEFORE UPDATING SOFTWARE!  
FIXTURE SOFTWARE CAN NOT BE DOWNGRADED!  
DOWNLOAD FIXTURE SOFTWARE TO PC ONLY! (NO MAC SUPPORT)  
PLEASE CONTACT ELATION SERVICE FOR FURTHER INFORMATION.**

An Elation E-Loader III can be used to update the fixture to the latest software. Please visit the E-Loader III product page at the Elation web site and download the product manual for step by step instructions.

<https://www.elationlighting.com/e-loader-iii-software-uploader>

To order the E-Loader III uploader and the updated software for your fixture, please contact Elation support for details.

# SOFTWARE UPDATES

## ETHERNET UPDATER

Software updates for this fixture can be performed using the Elation Ethernet Updater. Contact Elation Service to obtain this updater device:

**ELATION SERVICE USA - Monday - Friday 8:00am to 4:30pm PST**

323-582-3322 | support@elationlighting.com

**ELATION SERVICE EUROPE - Monday - Friday 08:30 to 17:00 CET**

+31 45 546 85 63 | Fax +31 45 546 85 96 | support@elationlighting.eu

The Elation Ethernet Updater is an EXE file, which only works on a PC System. Once you've received the Elation Ethernet Updater RAR file from Elation Service via email, download and extract the EXE file. With the file extracted, click Elation Ethernet Updater setupV100.exe to launch the installation wizard.



Follow the prompts once the Elation Ethernet Updater EXE has launched the Setup Wizard.

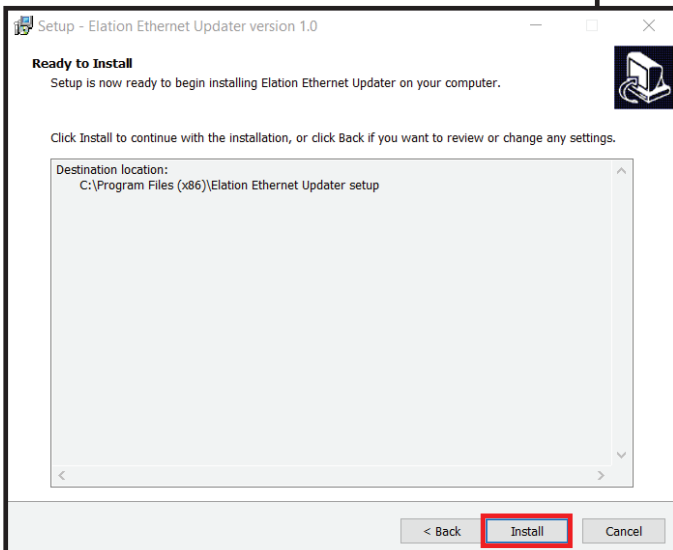
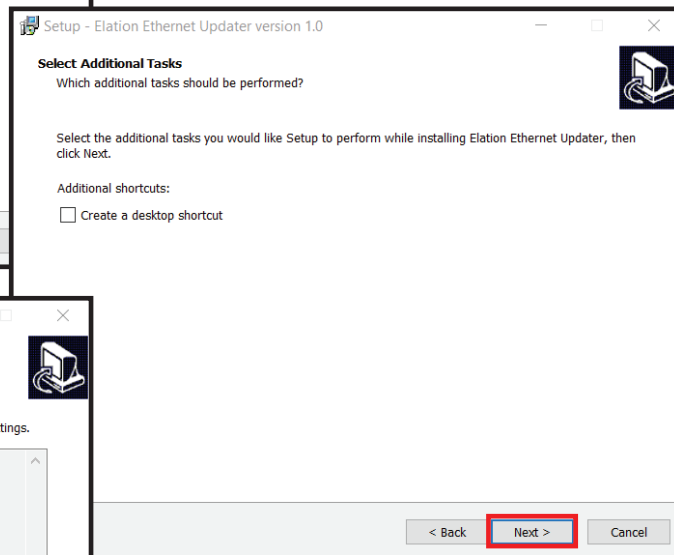
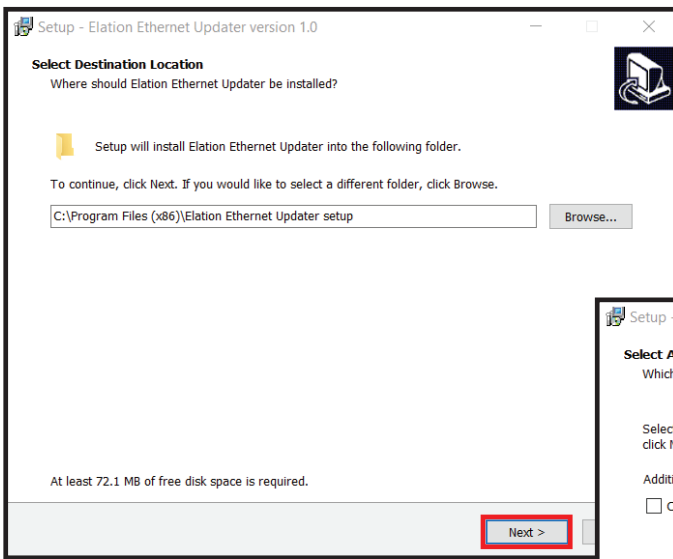

# SOFTWARE UPDATES

## ETHERNET UPDATER

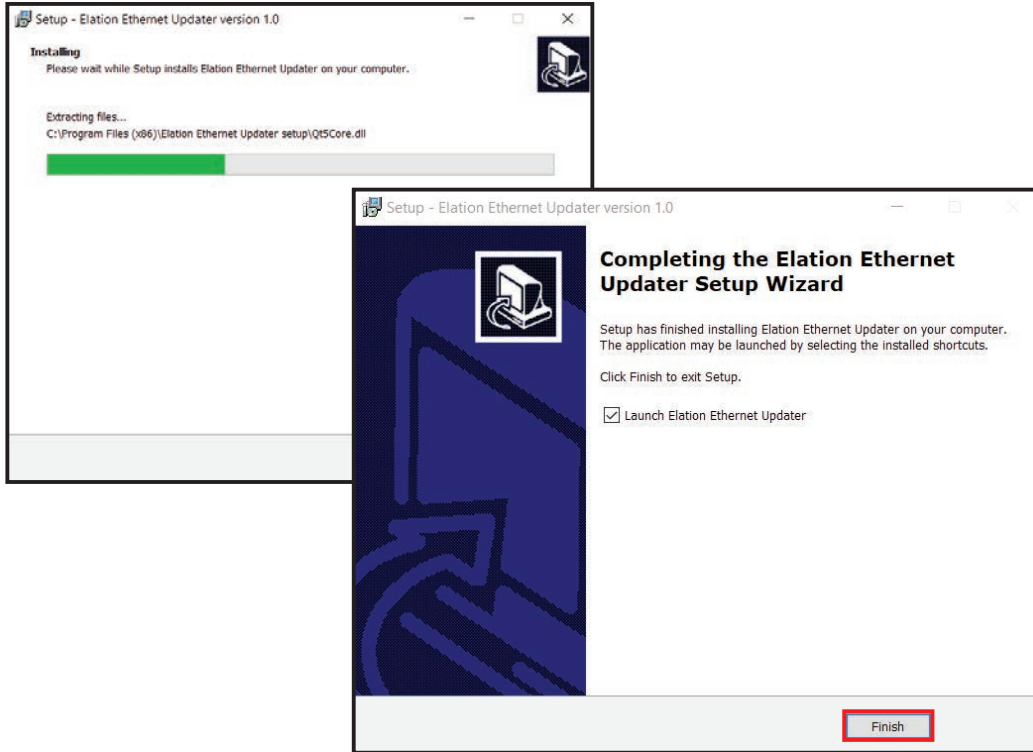

Once you have installed the Elation Ethernet Updater, it will launch automatically (unless you unchecked "Launch Elation Ethernet Updater"), or you can open it any time by clicking on the icon.

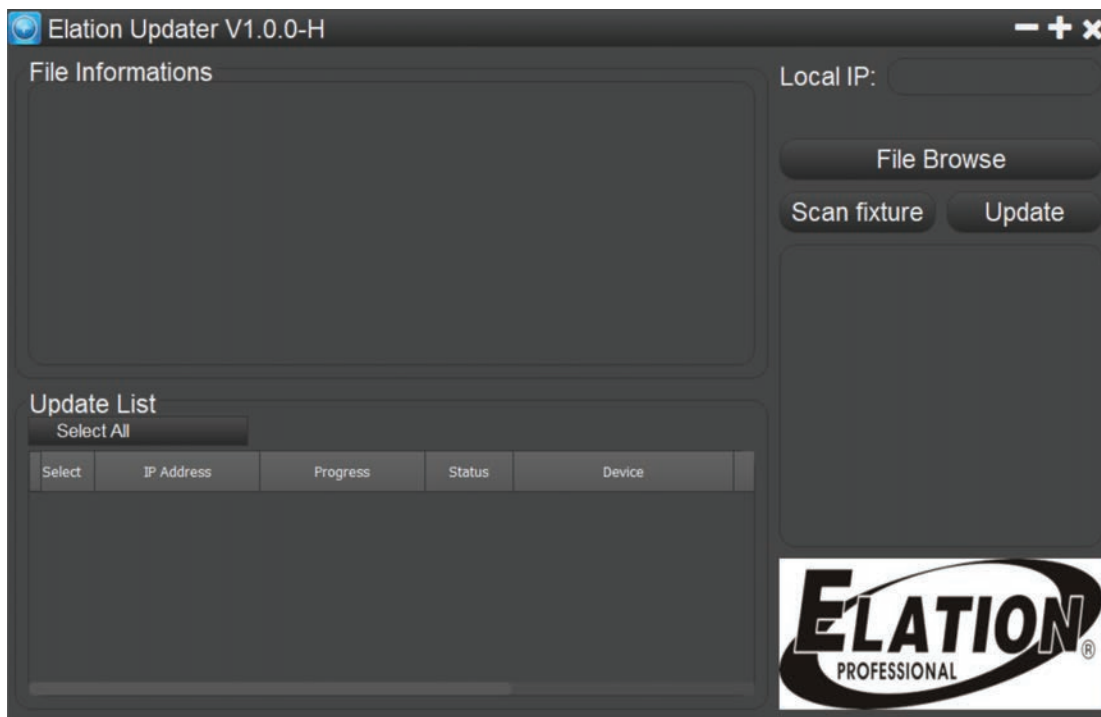

# SOFTWARE UPDATES

## ETHERNET UPDATER

Once opened, your local IP will automatically be identified. Click "Scan fixture" and create a connection. The fixture identity will appear in the Update List on the left side of browser. A connection will fail to establish if the fixture IP and Local IP are not in the same network segment.

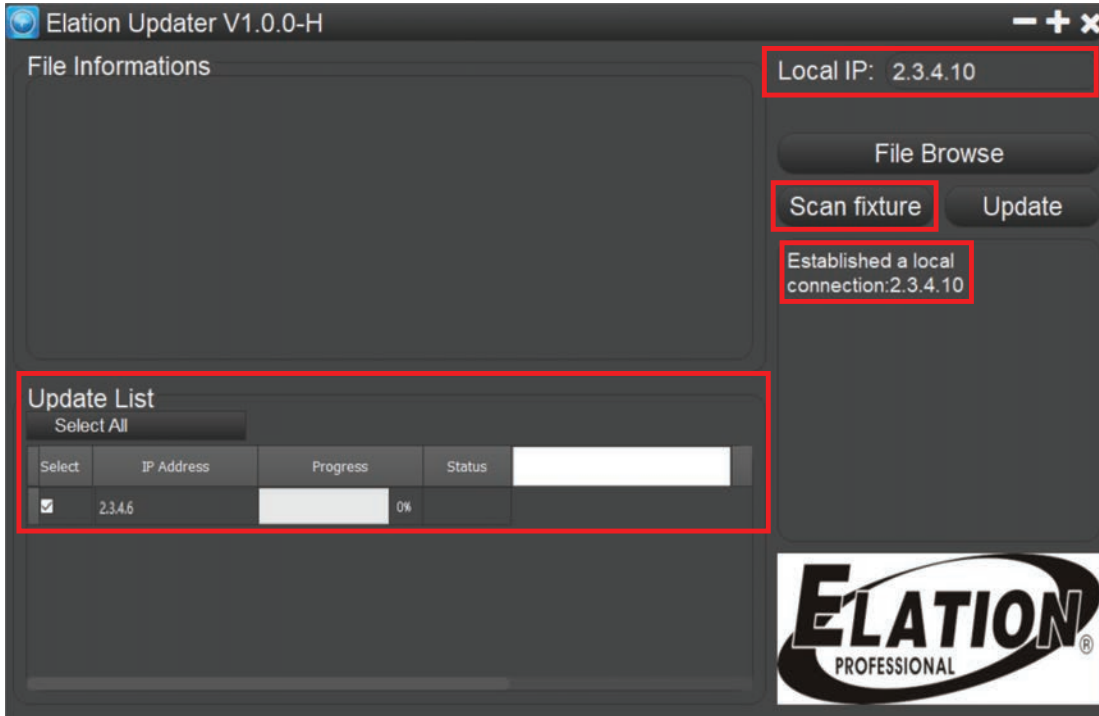

Click "File Browse" to select the files you want to download. The download Progress is displayed in the File information chart as a percentage bar graph.

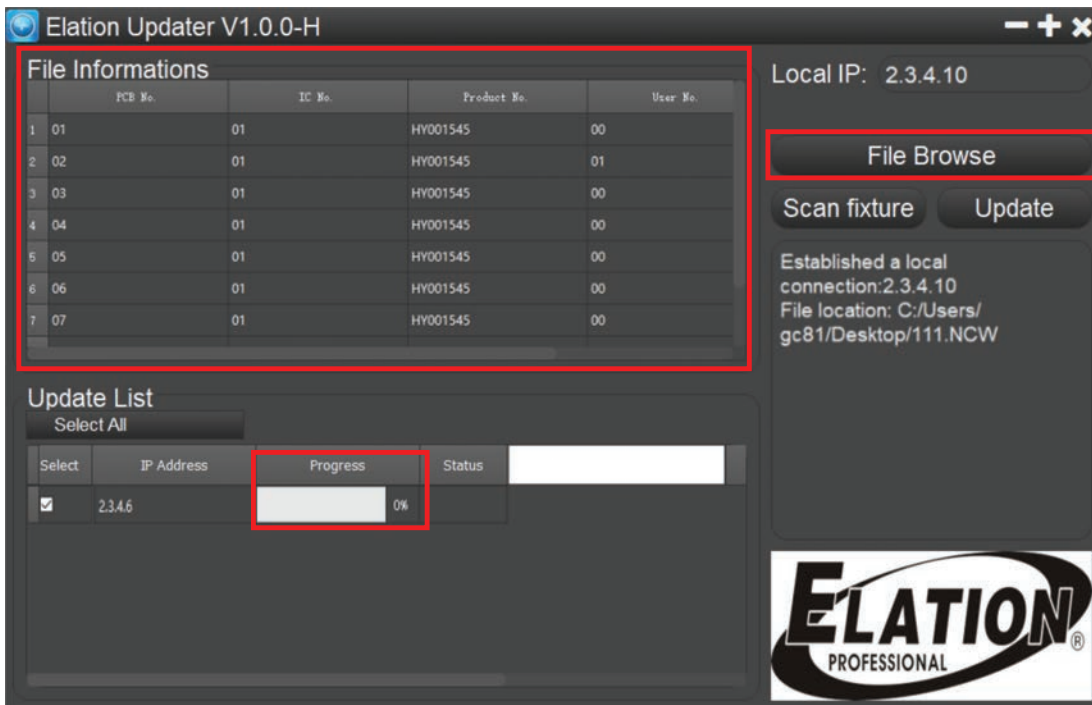



# MAINTENANCE GUIDELINES



**DISCONNECT POWER BEFORE PERFORMING ANY MAINTENANCE!**

## CLEANING

Frequent cleaning is recommended to ensure proper function, optimized light output, and an extended life. The frequency of cleaning depends on the environment in which the fixture operates: damp, smoky or particularly dirty environments can cause greater accumulation of dirt on the fixture's optics. Periodically clean the external lens surface with a soft cloth to avoid dirt/debris accumulation. **NEVER** use alcohol, solvents, or ammonia-based cleaners.

## MAINTENANCE

Regular inspections are recommended to ensure proper function and extended life. There are no user serviceable parts inside this fixture. Please refer all other service issues to an authorized Elation service technician. Should you need any spare parts, please order genuine parts from your local Elation dealer.

Please refer to the following points during routine inspections:

- A detailed electric check by an approved electrical engineer every three months, to make sure the circuit contacts are in good condition and prevent overheating.
- Be sure all screws and fasteners are securely tightened at all times. Loose screws may fall out during normal operation, resulting in damage or injury as larger parts could fall.
- Check for any deformations on the housing, color lenses, rigging hardware, and rigging points (ceiling, suspension, trussing). Deformations in the housing could allow for dust to enter into the fixture. Damaged rigging points or unsecured rigging could cause the fixture to fall and seriously injure a person(s).
- Electric power supply cables must not show any damage, material fatigue or sediments. **NEVER** remove the ground prong from the power cable.

# SPECIFICATIONS

## SOURCE

100W Laser Illuminated Light Engine  
6000K, CRI 70  
10,000 Hour Lamp Life

## PHOTOMETRIC DATA

2700 Lumen Total Fixture Output  
Beam Angle 0.9°

## EFFECTS

Dual Frost  
4 Prisms on Dual Planes  
CMY Color, Gobo, Prism Macros  
Motorized Focus  
Digital Shutter and Strobe

## COLOR

Full CMY Color Mixing System  
25 Position Color Wheel

## GOBOS

2 Gobo Wheels  
13 Interchangeable-Rotating / Indexing Metal Gobos  
24 Static-Stamped Metal Gobos

## CONTROL / CONNECTIONS

2 DMX Channel Modes  
(4) Button Touch Panel  
Full Color 180° Reversible LCD Menu Display  
DMX, RDM, Art-Net and sACN Protocol Support  
IP65 5pin DMX In/Out  
IP65 RJ45 Ethernet In/Out  
IP65 Locking Power In

## SIZE / WEIGHT

Length: 10.6" (270mm)  
Width: 15.5" (395mm)  
Height: 20.3" (516mm)  
Center-to-Center: 18.0" (456mm)  
Weight: 45.0 lbs. (20.4kg)

## ELECTRICAL / THERMAL

AC 100-240V 50/60Hz  
300W Max Power Consumption  
-4°F to 113°F (-20°C to 45°C)

## APPROVALS / RATINGS

CE | cETLus | IP66 | FCC

# DIMENSIONAL DRAWINGS

DRAWINGS NOT TO SCALE

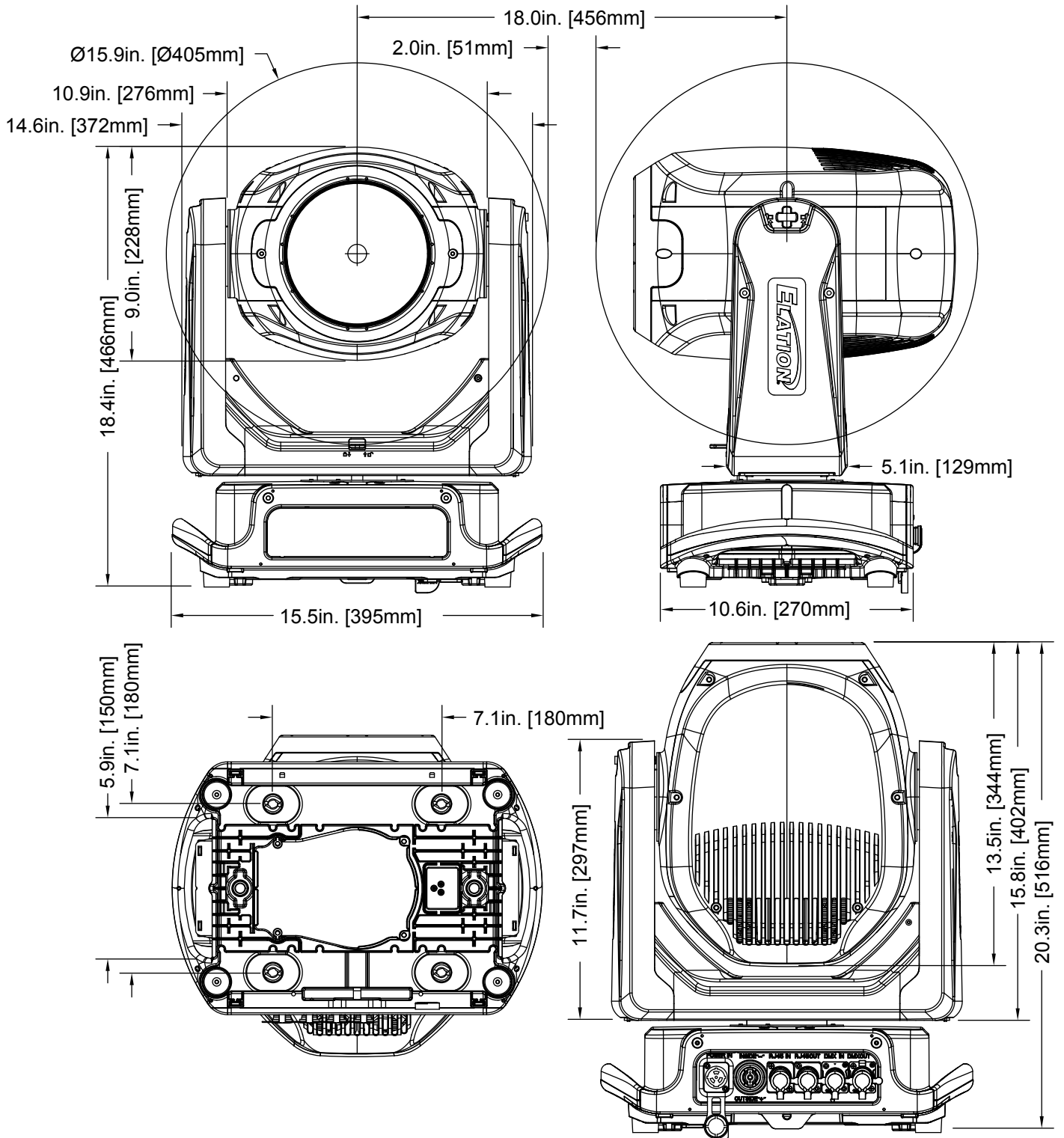

Specifications and documentation subject to change without notice.

# DIMENSIONAL DRAWINGS

DRAWINGS NOT TO SCALE

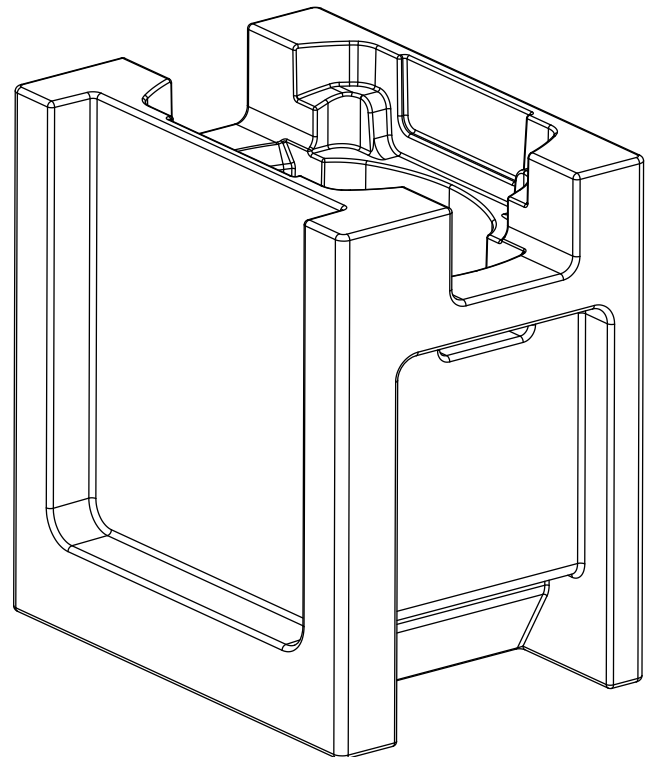
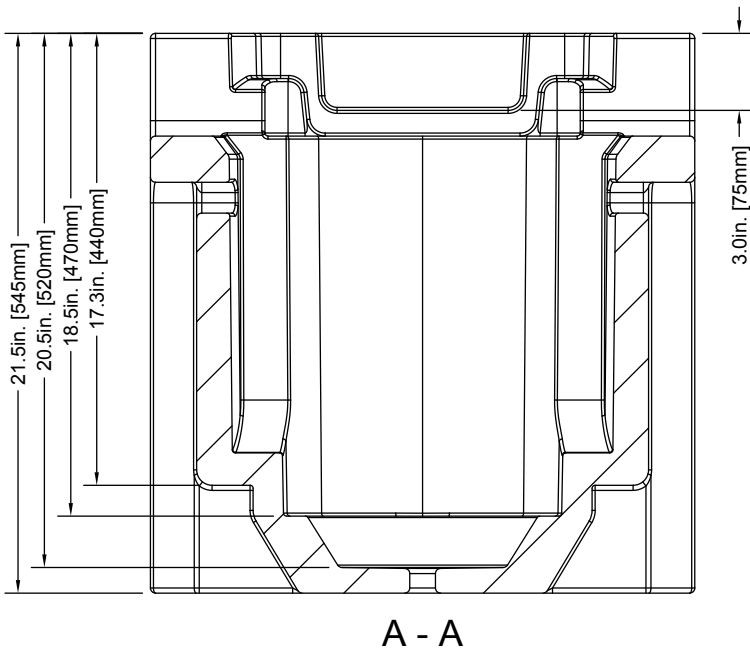
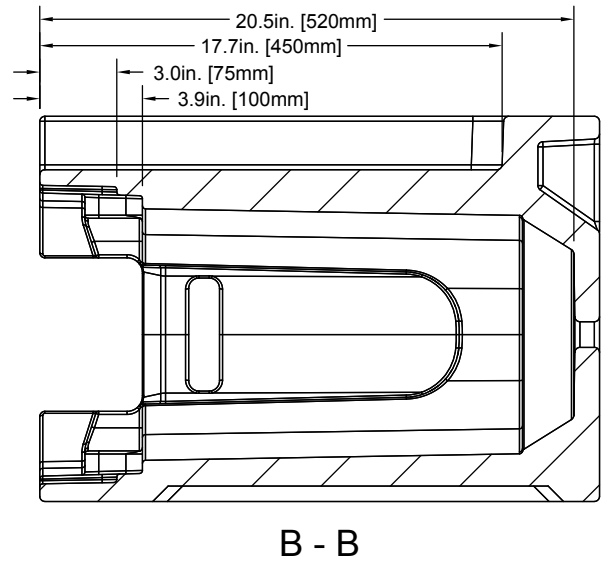
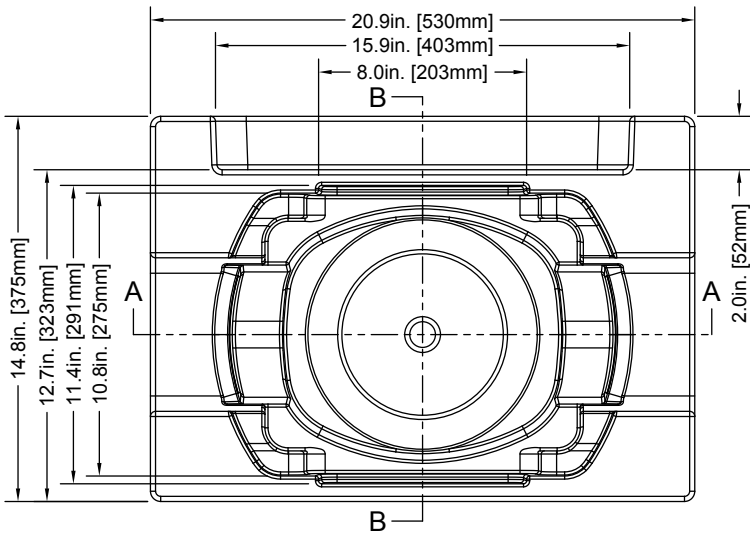

Specifications and documentation subject to change without notice.

# OPTIONAL ACCESSORIES

ORDER CODE		ITEM
US	EU	
PRD013	1237000272	Elation Proteus Radius
TRIGGER CLAMP	1741000032	Heavy Duty Wrap Around Hook Style Clamp
TOU027	N/A	Tour Link 5pin, 10 Ft, Tour Grade, DMX Data Cable
		Additional Cable Lengths Available



## FCC STATEMENT

This device complies with Part 15 of the FCC Rules. Operation is subject to the following two conditions: (1) this device may not cause harmful interference, and (2) this device must accept any interference received, including interference that may cause undesired operation.

## FCC RADIO FREQUENCY INTERFERENCE WARNINGS & INSTRUCTIONS

This product has been tested and found to comply with the limits as per Part 15 of the FCC Rules. These limits are designed to provide reasonable protection against harmful interference in a residential installation. This device uses and can radiate radio frequency energy and, if not installed and used in accordance with the included instructions, may cause harmful interference to radio communications. However, there is no guarantee that interference will not occur in a particular installation. If this device does cause harmful interference to radio or television reception, which can be determined by turning the device off and on, the user is encouraged to try to correct the interference by one or more of the following methods:

- Reorient or relocate the device.
- Increase the separation between the device and the receiver.
- Connect the device to an electrical outlet on a circuit different from which the radio receiver is connected.
- Consult the dealer or an experienced radio/TV technician for help.

## Energy Saving Matters (EuP 2009/125/EC)

Saving electric energy is a key to help protecting the environment. Please turn off all electrical products when they are not in use. To avoid power consumption in idle mode, disconnect all electrical equipment from power when not in use. Thank you!

# INDEX

- AC Power / Mains Input — 4, 8, 16, 19–20, 49
- Address via DMX — 29
- Aria Wireless DMX — 26–27
- Art-Net — 19, 27, 49
- Auto Program — 29–31
  
- Battery Compartment / Replacement — 8, 20, 26
- Beam Angle — 49
- Beam Safety — 6, 21–22
  
- Calibration — 27, 30
- Class 1 Risk Group 2 — 6, 9
- Cleaning — 5, 48
- CMY Color Mixing — 10, 27, 33, 39, 49
- Color Macros — 39, 49
- Color Wheel — 10, 34, 42, 49
- Control Panel / LCD Display — 8, 19, 26, 49
- Cooling — 4, 7, 23
- Custom Gobos — 12–13
  
- Data Cables — 4, 19–20
- Dielectric Grease — 5–6, 20
- Dimensional Drawings — 50–51
- Dimmer Curves — 27, 29, 32, 40
- Dimmer Modes — 32, 38
- DMX Address — 26–27, 29, 41
- DMX Channel Modes — 2, 27, 41, 49
- DMX Traits / Values — 28, 33–40
  
- Electrical Connections — 16, 20
- E-Loader III — 26, 43
- Error Codes — 42
- Ethernet / RJ45 — 4, 8, 19–20, 44–47, 49
- Ethernet Updater — 44–47
- External Light Beam Damage — 21–22
  
- Fan Control / Fan Modes — 23, 27–28
- FCC Statement — 52
- Fixed Gobo Wheel — 11, 36, 49
- Focus — 27, 37, 42, 49
- Frost — 38, 49
  
- Gobo Installation — 13
- Gobo Macros — 37, 49
- Gobo Specifications — 12
- Gobo Wheels — 10–13, 35–36, 49
- Grounding / Protection Class 1 — 6, 16, 24
  
- Hibernation Mode — 22, 27, 40
- Humidity / De-Humidification — 5, 15, 28
  
- IGMP — 19
- IP66 Rating — 5, 8, 14–16, 19–20, 24, 49
- IP Pressure Test — 14–15
- IP Tester — 14–15
  
- Laser Safety — 6, 9, 21
- Lens — 8, 14–15, 21–22, 48
- Low Noise Operation — 23
  
- Maintenance Guidelines — 5, 15, 48
- Maritime / Seaside Installations — 5
- Mounting / Rigging — 6–7, 16–18, 48
  
- No DMX Status — 22, 27
  
- Omega Brackets — 4, 9, 17
- Optional Accessories — 52
  
- Pan — 8, 27, 33, 39–42
- Pan/Tilt Speed — 27, 39–40
- Photometric Data — 49
- Power Linking — 16
- Prism Indexing / Rotation — 37
- Prisms — 37, 42, 49
  
- RDM / Remote Device Management — 41, 49
- Reset Functions — 27, 40, 42
- Rotating Gobo Indexing — 35
- Rotating Gobo Wheel — 10, 12–13, 35, 49
  
- sACN — 19, 27, 49
- Safety Cable — 9, 17–18
- Safety Guidelines — 6–7
- Service Password — 27, 29–30
- Shutter — 37, 49
- Sky Motion — 24–25
- Software Updates — 43–47
- Specifications — 49
- Strobe — 37, 49
- Sun Protection Mode — 22, 27
  
- Tilt — 8, 27, 33, 39–42
- Torque Settings — 14
- Truss Mounting — 16–18
  
- Vent Valves — 5, 15
  
- Warranty — 4, 6, 22

