

# **ELATION®**

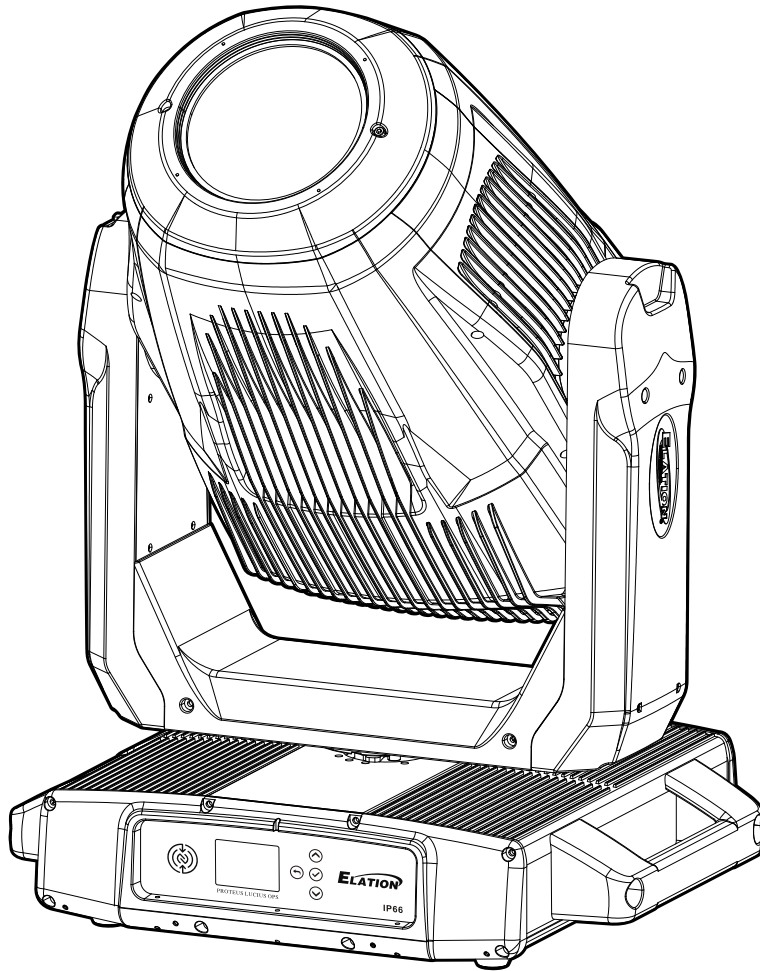

# **PROTEUS LUCIUS**

## **OPS**

### **user manual**

©2026 ELATION PROFESSIONAL all rights reserved. Information, specifications, diagrams, images, and instructions herein are subject to change without notice. ELATION PROFESSIONAL logo and identifying product names and numbers herein are trademarks of ELATION PROFESSIONAL. Copyright protection claimed includes all forms and matters of copyrightable materials and information now allowed by statutory or judicial law or hereinafter granted. Product names used in this document may be trademarks or registered trademarks of their respective companies and are hereby acknowledged. All non-ELATION brands and product names are trademarks or registered trademarks of their respective companies.

**ELATION PROFESSIONAL** and all affiliated companies hereby disclaim any and all liabilities for property, equipment, building, and electrical damages, injuries to any persons, and direct or indirect economic loss associated with the use or reliance of any information contained within this document, and/or as a result of the improper, unsafe, insufficient and negligent assembly, installation, rigging, and operation of this product.

**Elation Professional USA | 6122 S. Eastern Ave. | Los Angeles, CA. 90040**

323-582-3322 | [www.elationlighting.com](http://www.elationlighting.com) | [info@elationlighting.com](mailto:info@elationlighting.com)

**Elation Professional B.V. | Junostraat 2 | 6468 EW Kerkrade, The Netherlands**

+31 45 546 85 66 | [www.elationlighting.eu](http://www.elationlighting.eu) | [info@elationlighting.eu](mailto:info@elationlighting.eu)

**Elation Professional Mexico | AV Santa Ana 30 | Parque Industrial Lerma, Lerma, Mexico 52000**

+52 (728) 282-7070

## DOCUMENT VERSION



Due to additional product features and/or enhancements, an updated version of this document may be available online. Please scan the QR Code with your mobile device or visit [www.elationlighting.com](http://www.elationlighting.com) for the latest revision/update of this manual, before installation and/or programming.

Date	Document Version	SoftwareVersion ≥	DMX Channel Modes	Notes
05/29/2025	1.0	1.3.0	43 / 68	Initial Release
07/21/2025	1.1	V1.0.1	N/C	Updated Software, System Menu, DMX Traits
09/19/2025	1.2	N/C	N/C	Update information
01/21/2026	1.3	N/C	N/C	Added DMX Pinout Diagram
02/25/2026	1.4	N/C	N/C	Corrected Pinout Diagram
04/07/2026	1.5	N/C	N/C	Updated: System Menu, DMX Traits, Specifications

# CONTENTS

<b>General Information</b>	<b>4</b>
<b>Safety Guidelines</b>	<b>5</b>
<b>IP66 Rated</b>	<b>7</b>
<b>Overview</b>	<b>8</b>
<b>Colors and Gobos</b>	<b>9</b>
<b>Gobo Installation</b>	<b>13</b>
<b>Torque Settings for Screws</b>	<b>14</b>
<b>Fan Modes and Low Noise Operation</b>	<b>15</b>
<b>Installation Guidelines</b>	<b>16</b>
<b>Sun Protection Mode   Hibernation Mode</b>	<b>22</b>
<b>System Menu</b>	<b>23</b>
<b>Dimmer Curves   Dimmer Modes</b>	<b>25</b>
<b>DMX Traits: Channel Functions &amp; Values</b>	<b>26</b>
<b>Remote Device Management (RDM)</b>	<b>35</b>
<b>Error Codes</b>	<b>36</b>
<b>Maintenance Guidelines</b>	<b>37</b>
<b>Specifications</b>	<b>39</b>
<b>Dimensions</b>	<b>40</b>
<b>Optional Accessories   Fcc Statement</b>	<b>41</b>

# GENERAL INFORMATION

## FOR PROFESSIONAL USE ONLY

### INTRODUCTION

Please read and understand the instructions in this manual carefully and thoroughly before attempting to operate this device. These instructions contain important safety and use information.

### COOLING

After usage, the lamp may be switched off, but the fixture should remain connected to power in order to allow the fan time to cool down the fixture. OPS fixtures are not designed for 24/7 operation, and require periodic cooling intervals, especially in high temperature environments. Please refer to the **Duty Cycle and Thermal Management** section for detailed information.

### UNPACKING

Every device has been thoroughly tested and has been shipped in perfect operating condition. Carefully check the shipping carton for damage that may have occurred during shipping. If the carton is damaged, carefully inspect the device for damage, and be sure all accessories necessary to install and operate the device have arrived intact. In the event damage has been found or parts are missing, please contact our customer support team for further instructions. Please do not return this device to your dealer without first contacting customer support. Please do not discard the shipping carton in the trash. Please recycle whenever possible.

### BOX CONTENTS

Omega Brackets (x2)  
Stainless Steel Safety Cable

### CUSTOMER SUPPORT

Contact ELATION Service for any product related service and support needs. Also visit [forums.elationlighting.com](https://forums.elationlighting.com) with questions, comments or suggestions.

**ELATION SERVICE USA - Monday - Friday 8:00am to 4:30pm PST**  
**323-582-3322 | [support@elationlighting.com](mailto:support@elationlighting.com)**

**ELATION SERVICE EUROPE - Monday - Friday 08:30 to 17:00 CET**  
**+31 45 546 85 63 | [support@elationlighting.eu](mailto:support@elationlighting.eu)**

**REPLACEMENT PARTS** please visit [parts.elationlighting.com](https://parts.elationlighting.com)

### LIMITED WARRANTY

For up-to-date warranty information regarding your device, please visit Elation's warranty information page online or scan the QR codes below.



USA: <https://www.elationlighting.com/warranty-information>



EU: [https://www.elationlighting.eu/terms\\_and\\_conditions](https://www.elationlighting.eu/terms_and_conditions)

# SAFETY GUIDELINES

This fixture is a sophisticated piece of electronic equipment. To guarantee a smooth operation, it is important to follow all instructions and guidelines in this manual. Elation Professional is not responsible for injury and/or damages resulting from the misuse of this fixture due to the disregard of the information printed in this manual. Only qualified and/or certified personnel should perform installation of this fixture and only the original rigging parts (omega brackets) included with this fixture should be used for installation. Any modifications to the fixture and/or the included mounting hardware will void the original manufacturer's warranty and increase the risk of damage and/or personal injury.



**PROTECTION CLASS 1 - FIXTURE MUST BE PROPERLY GROUNDED.**



**THERE ARE NO USER SERVICEABLE PARTS INSIDE THIS UNIT.  
DO NOT ATTEMPT ANY REPAIRS YOURSELF; DOING SO WILL VOID YOUR  
MANUFACTURER'S WARRANTY. DAMAGES RESULTING FROM MODIFICATIONS  
TO THIS FIXTURE AND/OR THE DISREGARD OF SAFETY INSTRUCTIONS AND  
GUIDELINES IN THIS MANUAL VOID THE MANUFACTURE'S WARRANTY AND ARE  
NOT SUBJECT TO ANY WARRANTY CLAIMS AND/OR REPAIRS.**



**ENSURE ALL CONNECTIONS AND END CAPS ARE PROPERLY SEALED WITH A  
DIELECTRIC GREASE (AVAILABLE AT MOST ELECTRICAL SUPPLIERS) TO PREVENT  
WATER CORROSION AND/OR ELECTRICAL SHORT CIRCUIT.**



**DO NOT PLUG FIXTURE INTO A DIMMER PACK!  
NEVER OPEN THIS FIXTURE WHILE IN USE!  
UNPLUG POWER BEFORE SERVICING FIXTURE!  
NEVER TOUCH FIXTURE DURING OPERATION, AS IT MAY BE HOT!  
KEEP FLAMMABLE MATERIALS AWAY FROM FIXTURE!**



**NEVER LOOK DIRECTLY INTO THE LIGHT SOURCE!  
RETINA INJURY RISK - MAY INDUCE BLINDNESS!  
SENSITIVE PERSONS MAY SUFFER AN EPILEPTIC SHOCK!**



**MINIMUM DISTANCE TO OBJECTS/SURFACES  
MUST BE 9.8 FEET (3 METERS)  
MAXIMUM TEMP OF EXTERNAL SURFACE 194° F (90°C)  
MINIMUM DISTANCE OF INFLAMMABLE MATERIALS  
FROM THE SURFACE 1.6 FEET (0.5 METER)**

# SAFETY GUIDELINES



89.9 lbs. (40.8kg)

## WARNING

## TWO PERSON LIFT REQUIRED

## ! CAUTION

### HIGH INTENSITY ULTRAVIOLET LIGHT



AVOID DIRECT EYE & SKIN EXPOSURE.  
WEAR PROPER EYE & SKIN PROTECTION.  
SEE MANUAL FOR SAFETY INSTRUCTIONS.

RISK GROUP 3 - RISK OF EXPOSURE TO ULTRAVIOLET UV RADIATION! FIXTURE EMITS HIGH INTENSITY WAVELENGTH OF ULTRAVIOLET UV LIGHT FROM THE UV COLOR FILTER. WEAR PROPER EYE AND SKIN PROTECTION. AVOID PROLONGED PERIODS OF EXPOSURE TO UV COLOR FILTER. AVOID WEARING WHITE COLOR CLOTHING AND/OR USING UV PAINTS ON SKIN. AVOID DIRECT EYE AND/OR SKIN EXPOSURE AT DISTANCES LESS THAN 65.6 feet (20m). DO NOT OPERATE FIXTURE WITH DAMAGED/MISSING EXTERNAL COVERS. DO NOT LOOK DIRECTLY INTO THE UV LIGHT AND/OR VIEW UV LIGHT DIRECTLY WITH OPTICAL INSTRUMENTS THAT MAY CONCENTRATE THE LIGHT/RADIATION OUTPUT.

INDIVIDUALS SUFFERING FROM A RANGE OF EYE CONDITIONS, SUNLIGHT EXPOSURE DISORDERS, OR INDIVIDUALS USING PHOTSENSITIVE MEDICATION, MAY RECEIVE DISCOMFORT IF EXPOSED TO THE ULTRAVIOLET UV LIGHT EMITTED FROM THE UV LED.

DO NOT TOUCH the fixture housing during operation. Turn OFF the power and allow approximately 15 minutes for the fixture to cool down before serving.

DO NOT shake fixture, avoid brute force when installing and/or operating fixture.

DO NOT operate fixture if the power cord is frayed, crimped, damaged and/or if any of the power cord connectors are damaged and do not insert into the fixture securely with ease. NEVER force a power cord connector into the fixture. If the power cord or any of its connectors are damaged, replace it immediately with a new one of similar power rating.

DO NOT block any air ventilation slots.

All fan and air inlets must remain clean and never blocked.

Allow approx. 6" (15cm) between fixture and other devices or a wall for proper cooling.

Always disconnect fixture from main power source before performing any type of service and/or cleaning procedure. Only handle the power cord by the plug end, never pull out the plug by tugging the wire portion of the cord.

During the initial operation of this fixture, a light smoke or smell may emit from the interior of the fixture. This is a normal process and is caused by excess paint in the interior of the casing burning off from the heat associated with the lamp and will decrease gradually over time.

Consistent operational breaks will ensure fixture will function properly for many years.

ONLY use the original packaging and materials to transport the fixture in for service.

# IP66 RATED - OPS

**The International Protection (IP)** rating system is commonly expressed as “IP” (Ingress Protection) followed by two numbers (i.e. IP66), where the numbers define the degree of protection. The first digit (Foreign Bodies Protection) indicates the extent of protection against particles entering the fixture, and the second digit (Water Protection) indicates the extent of protection against water entering the fixture. An **IP66** rated lighting fixture is designed and tested to protect against the ingress of dust (**6**), and high-pressure water jets from any direction (**6**).

**The Atmospheric Corrosion rating** indicates the degree of protection that a surface coating provides against corrosion. It is commonly expressed as the letter C, followed by a number from 1 to 5 or the letter X. This fixture is rated as **CX (extreme)**, which means it is designed to provide protection in areas of high salinity, industrial areas exposed to extreme humidity, aggressive atmospheres, or tropical areas.

**Maritime/Seaside Environment Installations:** A maritime/seaside environment is adjacent to the sea and caustic to electronics through exposure to atomized salt water and humidity, whereas a coastal environment extends 5 miles inland.

A duty-cycle may also be needed when units are not in use. During times of high humidity and colder temperatures, condensation may occur internally so the fixture may require a duty-cycle to bring it up to running temperature, allowing any accumulation of moisture to be expelled via the vent valve. Recommendations can change based on installation environmental circumstances.

**NOTE: NOT ALL FEATURES LISTED ARE AVAILABLE ON ALL FIXTURES; THE FOLLOWING INSTRUCTIONS MAY NOT APPLY. CONTACT SUPPORT FOR ADDITIONAL DETAILS.**

**Exterior Maintenance:** Please note that the following are best practices, which are recommended but not required. Inspect the exterior every 30-days. The unit must be powered off/disconnected. The chassis should be inspected for any signs of contaminants. Inspect optics to determine if the lens is obstructed, then clean optics and chassis accordingly. Based on initial finding, schedule maintenance accordingly, keeping in mind that exterior maintenance will be required. Even if the luminaires are NOT in use, maintenance will still be needed given its location (exterior use). The use of a durable type of wax on the chassis is recommended since it will help prevent contaminant build up. Inspect both power and data lines for any signs of contaminants or corrosion. Periodically reapplying di-electric grease, especially in coastal environments. If any signs of corrosion/contaminants are present, clean thoroughly, and/or replace connectors, then reapply di-electric grease. Typically, this should be done annually, or any time an opportunity presents itself. As a preventive measure, annual replacement of both vent valves is recommended. The vent valve membrane can become contaminated and/or clogged causing improper venting of humidity within the luminaire. Inspect all mounting hardware as a precaution.

**Interior Maintenance:** Inspect the interior every 30-days. The unit must be powered off/disconnected.

- Inspect zoom/focus mechanism, clean optics, lubricate linear bearings (Krytox oil) as needed, inspect belts for wear
- Inspect all rotating effect wheels, manually rotate them, note any resistance
- Inspect all remaining rotating belts for any wear
- Inspect all fans, clean as needed, check rotation, check connections
- Inspect CMY module, manually move flags and check for signs of resistance, and if needed, clean guide rods first, then reapply a thin layer of grease (moly lube)
- Clean interior with low-volume compressed air, then clean optics prior to reassembly of head covers

Although the base has limited moving parts, the pan belt should also be inspected for wear. Remember to always perform an IP test anytime a cover is removed.

There is no specific time frame regarding the routine replacement of parts such as belts/stepper motors, PCBs, or LEDs. These items should only be replaced on an as needed bases, except for cooling fans, which should be replaced once the luminaries reach 10,000-hours. This is a prophylactic measure intended to keep the unit running as cool as possible, insuring proper function of all internal components. A complete service breakdown is available, please contact [service@elationlighting.com](mailto:service@elationlighting.com) for any needed parts or manuals.

# OVERVIEW

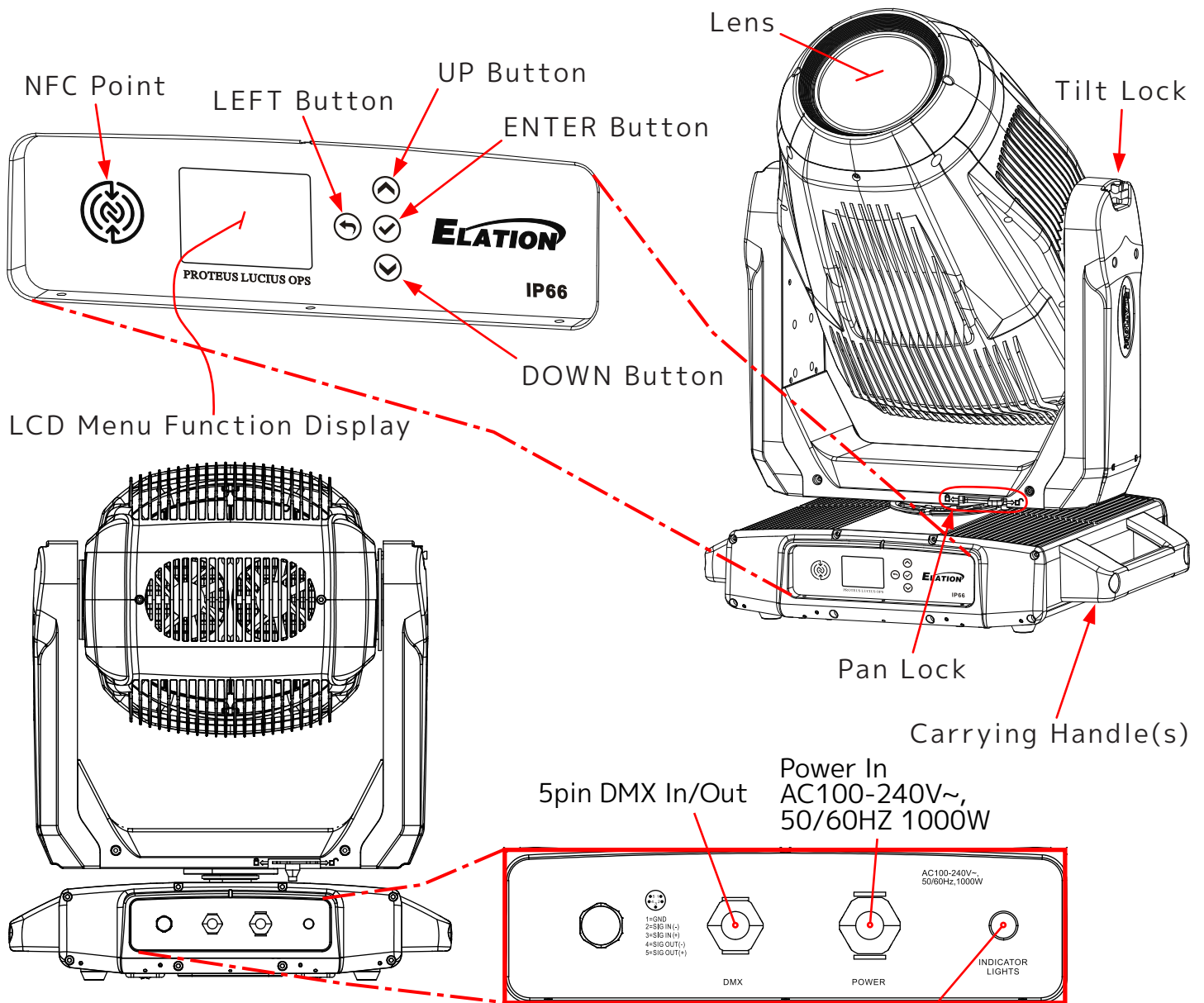

\*Indicator Lights

\*Indicator Light - **Green** light indicates that the fixture is working normally, a **Blinking Yellow** light indicates that the fixture is resetting or receiving a software update, **Orange** indicates hibernation, and a **Red** light indicates that the fixture is experiencing an error. See table on page 9 for full list of LED States.

Safety Cable Attachment Point



**ALWAYS ATTACH A SAFETY CABLE WHENEVER INSTALLING THIS DEVICE IN A SUSPENDED ENVIRONMENT TO ENSURE THE FIXTURE WILL NOT DROP IF THE CLAMP FAILS.**

# COLORS AND GOBOS

## COLOR FLAGS

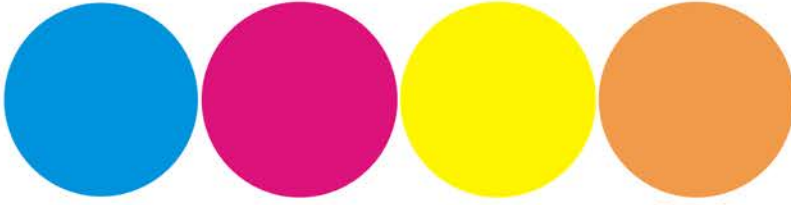

CYAN      MAGENTA      YELLOW      C.T.O.

## COLOR WHEEL



RED      GREEN      HIGH CRI      ORANGE      BLUE

## INTERCHANGEABLE – ROTATING GLASS GOBO WHEEL



Pos. 1      Pos. 2      Pos. 3      Pos. 4      Pos. 5      Pos. 6

## INTERCHANGEABLE – ROTATING GLASS GOBO WHEEL



Pos. 1      Pos. 2      Pos. 3      Pos. 4      Pos. 5      Pos. 6      Pos. 7

## INTERCHANGEABLE STATIC – FIXED GLASS GOBO WHEEL



Pos. 1      Pos. 2      Pos. 3      Pos. 4      Pos. 5      Pos. 6      Pos. 7

## BI-DIRECTIONAL ANIMATION WHEEL

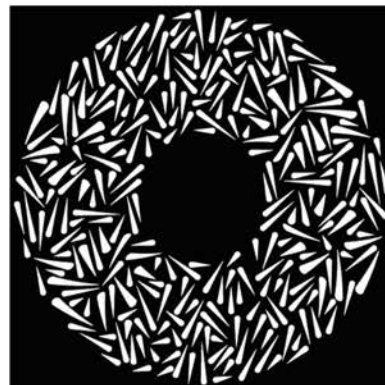

# COLORS AND GOBOS

ROTATING WHEEL1 GOBOS - Pos. 1-5:	
Gobo Holder Diameter	Ø34mm
Gobo O.D. (Max. Outer Diameter)	Ø33.8mm
Gobo I.D. (Max. Image Diameter)	Ø21mm
Gobo Thickness	1.1mm±0.1mm
Gobo Material	CORNING

ROTATING WHEEL1 GOBOS - Pos. 6:	
Gobo Holder Diameter	Ø34mm
Gobo O.D. (Max. Outer Diameter)	Ø34mm
Gobo I.D. (Max. Image Diameter)	Ø21mm
Gobo Thickness	2.5mm±0.1mm
Gobo Material	GLASS

## ROTATING WHEEL1 GOBOS

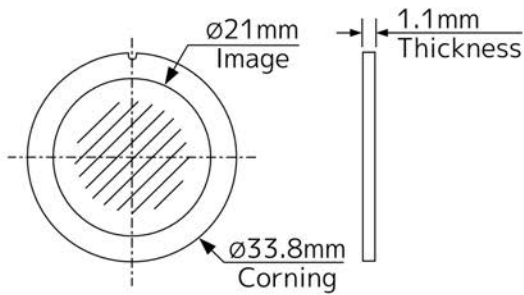

Pos. 1 - Pos. 5

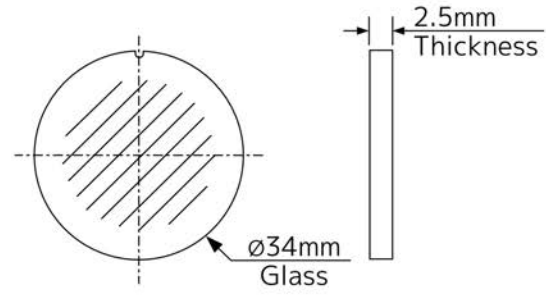

Pos. 6

## ROTATING WHEEL1 GOBO HOLDERS

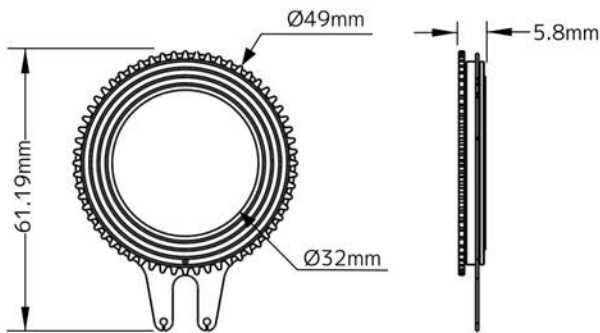

5.01.02.01.0685-0

Pos. 1 - Pos. 5

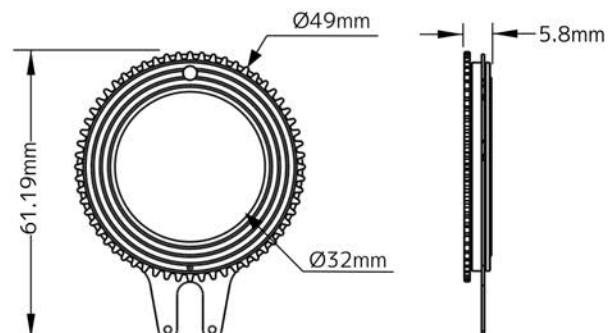

5.01.02.01.0599-0

Pos. 6

Proteus Lucius OPS utilizes different size gobo holders on every wheel.

**Please be aware of the intended position and correct sizing requirements of custom gobos.**

**\*\*\* IMPORTANT NOTICE REGARDING CUSTOM GOBOS \*\*\***

Due to the high temperature optical system, special glass material is required for custom gobos. Due to varying manufacturing processes and tolerances, it is highly recommended to provide a gobo sample and holder from the fixture to the custom gobo vendor for accurate sizing. Extended testing of custom gobo designs is highly recommended prior to use. Contact ELATION SERVICE for further information.

**ELATION SERVICE USA** -Monday -Friday 8:00am to 4:30pm PST  
323-582-3322 | support@elationlighting.com

**ELATION SERVICE EUROPE** -Monday -Friday 08:30 to 17:00 CET  
+31 45 546 85 63 | support@elationlighting.eu

# COLORS AND GOBOS

ROTATING WHEEL2 GOBOS - Pos. 1-6:	
Gobo Holder Diameter	Ø27mm
Gobo O.D. (Max. Outer Diameter)	Ø26.8mm
Gobo I.D. (Max. Image Diameter)	Ø21mm
Gobo Thickness	1.1mm±0.1mm
Gobo Material	CORNING

ROTATING WHEEL2 GOBOS - Pos. 7:	
Gobo Holder Diameter	Ø27mm
Gobo O.D. (Max. Outer Diameter)	Ø26.8mm
Gobo I.D. (Max. Image Diameter)	Ø21mm
Gobo Thickness	2.5mm±0.1mm
Gobo Material	CORNING

## ROTATING WHEEL2 GOBOS

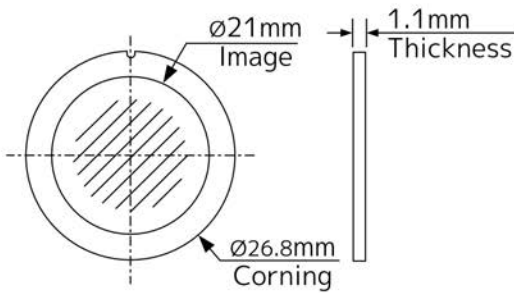

Pos. 1 - Pos. 6

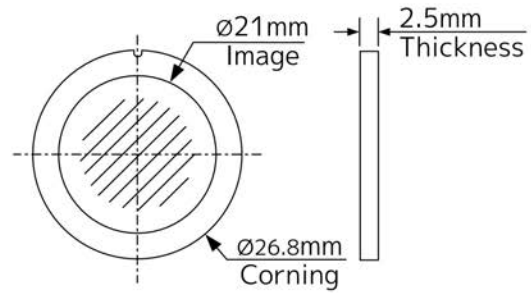

Pos. 7

## ROTATING WHEEL2 GOBO HOLDERS

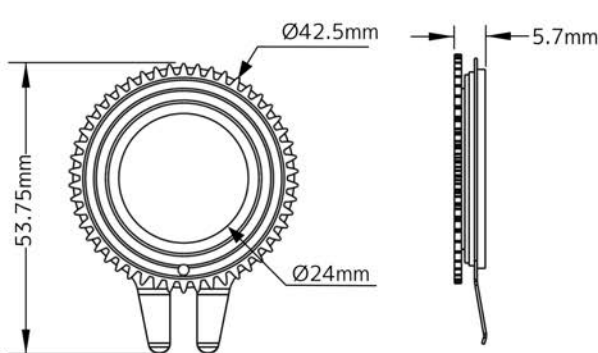

5.01.02.01.0684-0

Pos. 1 - Pos. 6

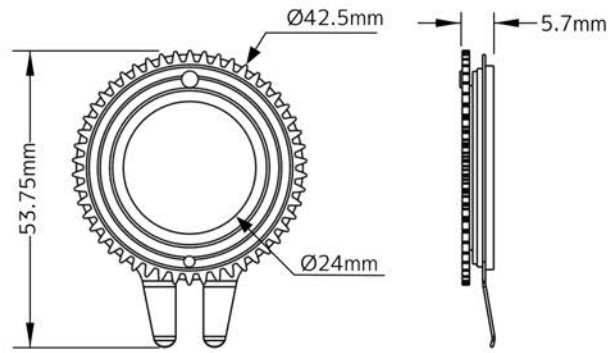

5.01.02.01.0598-0

Pos. 7

Proteus Lucius OPS utilizes different size gobo holders on every wheel.

**Please be aware of the intended position and correct sizing requirements of custom gobos.**

**\*\*\* IMPORTANT NOTICE REGARDING CUSTOM GOBOS \*\*\***

Due to the high temperature optical system, special glass material is required for custom gobos. Due to varying manufacturing processes and tolerances, it is highly recommended to provide a gobo sample and holder from the fixture to the custom gobo vendor for accurate sizing. Extended testing of custom gobo designs is highly recommended prior to use. Contact ELATION SERVICE for further information.

**ELATION SERVICE USA** -Monday -Friday 8:00am to 4:30pm PST  
323-582-3322 | support@elationlighting.com

**ELATION SERVICE EUROPE** -Monday -Friday 08:30 to 17:00 CET  
+31 45 546 85 63 | support@elationlighting.eu

# COLORS AND GOBOS

FIXED WHEEL GOBOS:	
Gobo Holder Diameter	Ø30mm
Gobo O.D. (Max. Outer Diameter)	Ø29.8mm
Gobo I.D. (Max. Image Diameter)	Ø21mm
Gobo Thickness	1.1mm±0.1mm
Gobo Material	CORNING

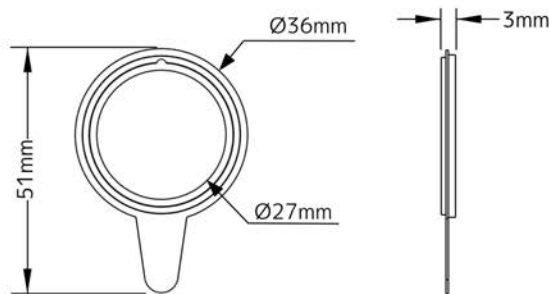
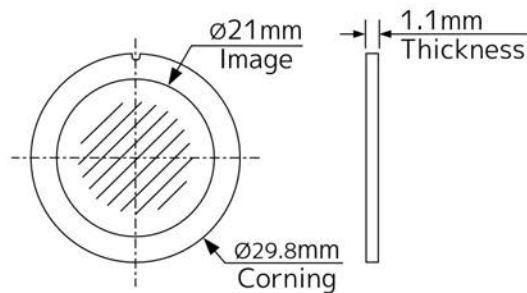

5.01.02.01.0694-0

Proteus Lucius OPS utilizes different size gobo holders on every wheel.

**Please be aware of the intended position and correct sizing requirements of custom gobos.**

**\*\*\* IMPORTANT NOTICE REGARDING CUSTOM GOBOS \*\*\***

Due to the high temperature optical system, special glass material is required for custom gobos. Due to varying manufacturing processes and tolerances, it is highly recommended to provide a gobo sample and holder from the fixture to the custom gobo vendor for accurate sizing. Extended testing of custom gobo designs is highly recommended prior to use. Contact ELATION SERVICE for further information.

**ELATION SERVICE USA** -Monday -Friday 8:00am to 4:30pm PST  
323-582-3322 | support@elationlighting.com

**ELATION SERVICE EUROPE** -Monday -Friday 08:30 to 17:00 CET  
+31 45 546 85 63 | support@elationlighting.eu

# GOBO INSTALLATION



## REPLACING A ROTATING GOBO

Locate the specific Rotating GOBO to replace. Carefully grip the GOBO using your thumb and index



Locate the tab of the spring, and with a precision pick (or similar tool), carefully press the retaining spring inward to relieve the tension. Remove the retaining spring and carefully separate the GOBO from the GOBO Holder. Lastly, remove the flat washer attached to the removed GOBO and attach it to the desired replacement GOBO. Install the replacement Rotating GOBO following the steps above in reverse order.

**CAUTION: TAKE CARE NOT TO SCRATCH GOBO OR GOBO HOLDER**

## REPLACING A STATIC GOBO



Rotate the Static GOBO Wheel until the desired GOBO is visible through the OPEN slot in the Rotating GOBO Wheel. Using a precision pick (or similar tool), carefully press the Static GOBO Holder down slightly, then using your thumb and index finger, gently pull it out and away until it fully clears the GOBO Wheel.

Locate the tab of the retaining spring. Using a precision pick (or similar tool), carefully press the retaining spring inward to relieve the tension. Remove the retaining spring and carefully separate the GOBO from the GOBO Holder. Lastly, remove the flat washer attached to the removed GOBO and attach it to the desired replacement GOBO. Install the replacement Static GOBO following the steps above in reverse

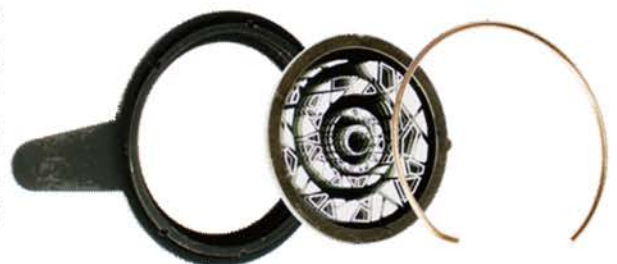

# TORQUE SETTINGS FOR SCREWS

The hex-head screws holding either the panels or the base MUST be tightened with a torque wrench (not included).

**TORQUE SETTING**  
**11 lbf-in. (12.7kgf-cm)\***

\* lbf-in = Pound Force Inches  
 kgf-cm = Kilogram Force Centimeters



**CAUTION! DO NOT OVER TORQUE SCREWS AS THIS CAN CAUSE LEAKAGE ISSUES! TO CONFIRM THE IP66 INTEGRITY AFTER A LAMP REPLACEMENT, TEST FIXTURE USING THE ELATION IP TESTER. CONTACT ELATION SERVICE FOR MORE DETAILS.**



**CAUTION! THE USE OF PROTECTIVE GLOVES AND SAFETY GOGGLES IS STRONGLY RECOMMENDED WHILE PERFORMING THE IP PRESSURE TEST! AVOID PLACING YOUR FACE, EYES, HANDS, ETC IN CLOSE PROXIMITY TO THE FIXTURE'S LENS WHILE PERFORMING THE TEST!**

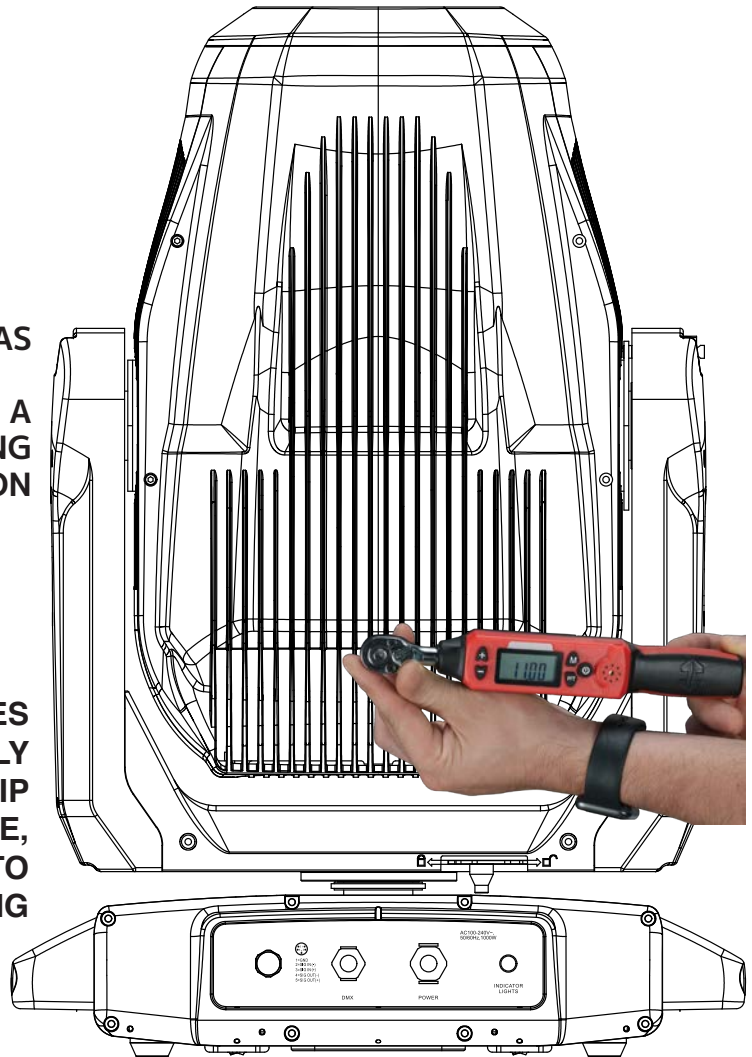

IP PRESSURE TESTING PARAMETERS	Low Pressure Limit	High Pressure Limit	Hold Time
Test Type			
Vacuum Test	-4.35psi (-30.00 KPa)	-5.08 psi (-35.00 KPa)	10s
Pressure Test	3.62 psi (25.00 KPa)	4.35 psi (30.00 KPa)	10s



# FAN CONTROL AND LOW NOISE OPERATION

The Elation Proteus Lucius OPS is a high-performance fixture suited for multiple applications. For noise critical environments such as Theater, Opera, or Orchestral Halls, it offers various fan operation modes which remove unwanted noise distractions for the audience and performers. Fan Modes can be changed remotely via the DMX control channel, allowing the fixture to offer high output or whisper-silent operation at a moment's notice. All Fan Modes smoothly transition over a brief period, preventing unwanted attraction to the fixture.

Mode	dbA at 1m LED off	dbA at 1m Dimmer 100%
Fan Control - Auto (Default)	39	47
Fan Control - High	40	55
Fan Control - Low	37	42
Low Noise – Studio	34	37
Low Noise – Mute/Silent	31	31

**Auto (Default)** – Fans only run at the speeds needed to keep the LED engine within a safe temperature range, and ensures optimal performance of the fixture. They will turn off if possible; for example, when the fixture is dimmed to a low intensity. Fans sense the ambient and fixture temperature and will, at all times, try to keep noise levels at a minimum. The fixture output will only be reduced when the LED engine cannot be cooled to its safe operating range due to a high ambient temperature.

**NOTE: This mode is recommended for daily operation.**

**Silent** – Fan speeds are reduced throughout the fixture for a lower noise profile. The fixture output is also reduced to approximately 80%. This mode should be sufficient for most uses where lower noise is required.

**High** – Fan speeds are increased throughout the fixture for the most efficient cooling. This mode will increase wear on the fans and should only be utilized in exceptional circumstances. Fans will always run, even if the fixture is dimmed. Fixture output is kept at 100% unless the LED engine temperature reaches an unsafe temperature, at which point the fixture will reduce power carefully to ensure continued safe operation. This mode is only required in very high ambient temperatures when automatic fan speed adjustments are not desired.

## Low Noise Modes

For very critical noise environments, the fixture offers two additional Low Noise Modes for silent operation. The fixture output will be reduced, yet due to the extremely high luminous flux, the fixture still offers outstanding performance. In Low Noise Modes, all parameters of the fixture operate more quietly with reduced fan speeds.

**Mute** – All but one fixture fan is turned off for whisper-quiet operation. The fixture LED power output is reduced to 25%.

# INSTALLATION GUIDELINES



## **FLAMMABLE MATERIAL WARNING**

Keep fixture minimum 9.8 feet (3m) away from flammable materials and/or pyrotechnics.



## **ELECTRICAL CONNECTIONS**

A qualified electrician should be used for all electrical connections and/or installations.



## **MINIMUM DISTANCE TO OBJECTS/SURFACES MUST BE 1.6 FOOT (0.5 METERS)**



## **MINIMUM DISTANCE OF INFLAMMABLE MATERIALS FROM THE SURFACE 1.6 FEET (0.5 METER)**



## **AMBIENT TEMPERATURE RANGE IS -4° F TO 113° F (-20°C TO 45°C)**



## **DO NOT INSTALL THE FIXTURE IF YOU ARE NOT QUALIFIED TO DO SO!**

Fixture **MUST** be installed following all local, national, and country commercial electrical and construction codes and regulations.

Before rigging/mounting the fixture to any metal truss/structure or placing the fixture on any surface, a professional equipment installer **MUST** be consulted to determine if the metal truss/structure or surface is properly certified to safely hold the combined weight of the fixture, clamps, cables, and accessories.

Overhead rigging requires extensive experience, including, amongst others, calculating working load limits, installation material being used, and periodic safety inspection of all installation material and the fixture. If you lack these qualifications, do not attempt the installation yourself. Improper installation can result in bodily injury.

Fixture ambient operating temperature range is **-4° to 113°F. (-20° to 45°C).**

Do not use the fixture under or above this temperature.

Fixture should be installed in areas outside walking paths, seating areas, or away from areas where unauthorized personnel might reach the fixture by hand.

**NEVER** stand directly below the fixture when rigging, removing or servicing.

Overhead fixture installation must always be secured with a secondary safety attachment, such as an appropriately rated safety cable.

Allow approximately 10 minutes for the fixture to cool down before serving.

# INSTALLATION GUIDELINES

## DMX Hardwire Guidelines for OPS Moving Head Installation (IP66-rated)

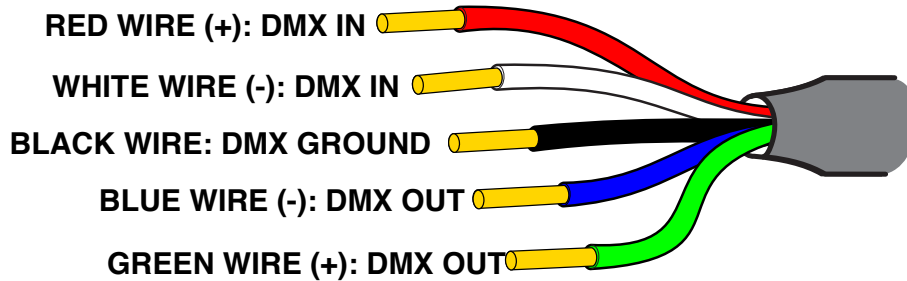

### Power Connection

Connect via IP66 locking power In/Out to 100–240V AC 50/60Hz overload-protected supply. Use surge protection to safeguard control and power electronics.

### In-Rush Current

LED fixtures exhibit brief in-rush current on power-up due to switching power supplies. Limit fixtures per power input to avoid over-current trips (refer to model-specific manual for power ratings and derating).

### Wired DMX Control (Hardwire Option)

For custom hardwire installations, use shielded twisted-pair RS-485 cable (120  $\Omega$  impedance, e.g., Belden 9841). Daisy-chain as shown. Install 120  $\Omega$  terminator across DMX + and DMX - at the last fixture.

### DMX Wiring Diagram

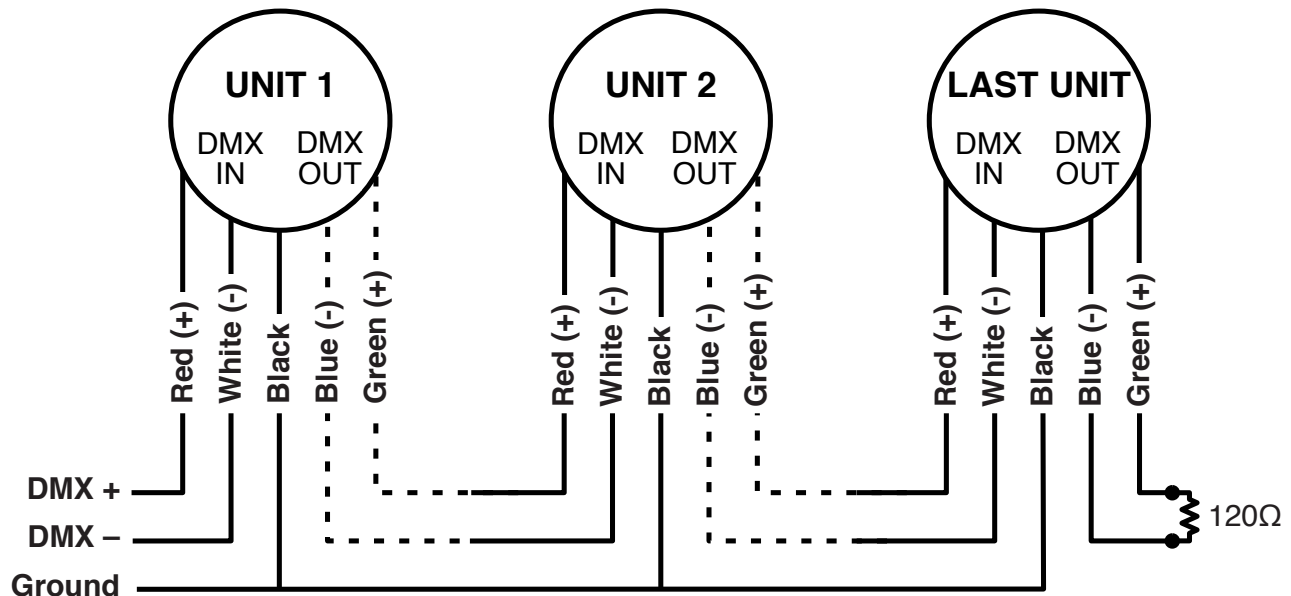

### DMX Best Practices

- Max total cable length: 3,900 ft (1,200 m) without buffer
- Max 32 fixtures per line without buffer
- Use 120  $\Omega$  twisted-pair shielded cable
- Always terminate last fixture with 120  $\Omega$  resistor
- No passive Y-splits; use powered splitter/buffer if needed
- Never cross DMX + and DMX -

### Installation Requirements

- Use overload-protected supply
- Seal all cable access points and enclosures
- Follow local codes during planning and installation
- Use suitable connectors in junction boxes
- Connections must be made, inspected, and certified by a qualified electrician

# INSTALLATION GUIDELINES

## OMEGA BRACKETS WITH CLAMP INSTALLATION

Insert the Omega Brackets into the matching holes on the bottom of the fixture. Secure the Omega Brackets to the fixture by turning each quick-lock fastener ¼ turn clockwise; making sure the fastener is completely locked. Omega Brackets can be installed into the fixture base as illustrated below.

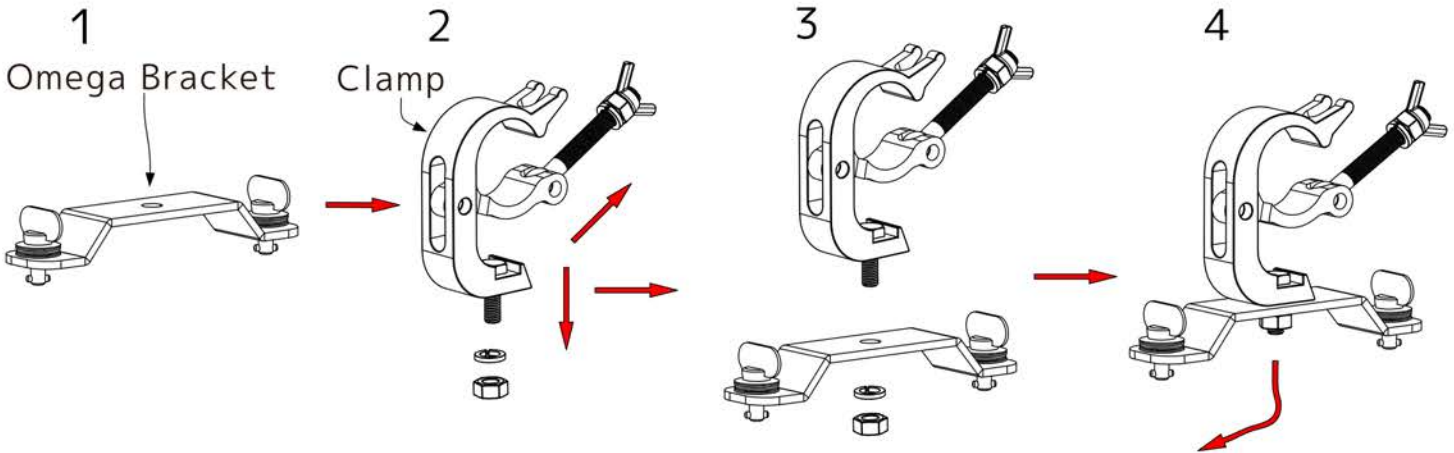

## SAFETY CABLE

**ALWAYS ATTACH AN APPROPRIATELY RATED SAFETY CABLE WHENEVER INSTALLING THIS FIXTURE IN A SUSPENDED ENVIRONMENT TO ENSURE THE FIXTURE WILL NOT FALL IF THE CLAMP FAILS.**

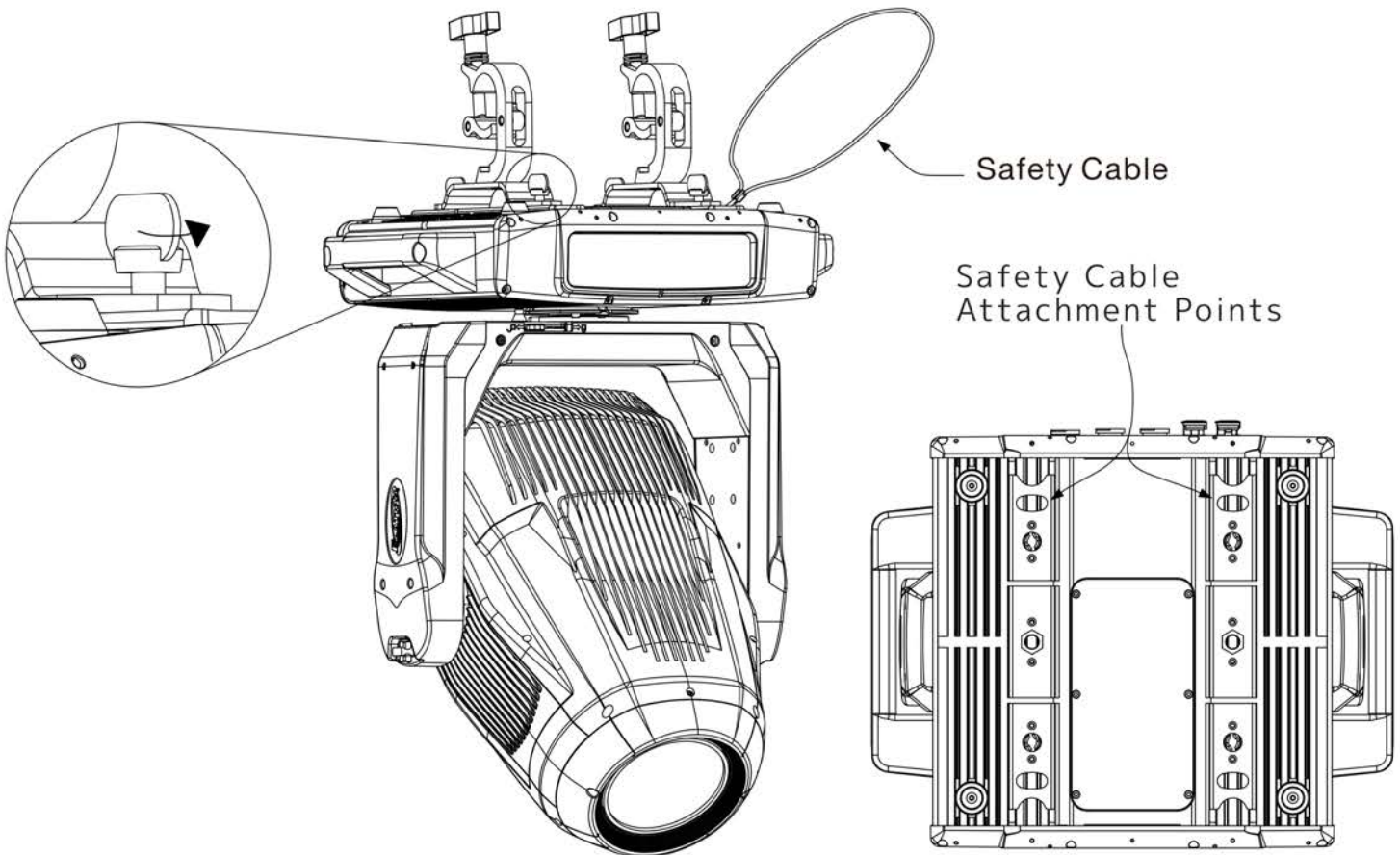

## MOUNTING THE FIXTURE ON A TRUSS USING CLAMPS WITH OMEGA BRACKETS

When mounting the fixture to a truss, be sure to secure an appropriately rated professional grade rigging clamp to the included **Omega Brackets** using an M10 screw fitted through the center hole of the **Omega Brackets**. The fixture provides built-in rigging points for a **SAFETY CABLE** (not included). Be sure to only use one of the designated rigging points for the safety cable and never secure a safety cable to a carrying handle.

# INSTALLATION GUIDELINES

## CLAMP INSTALLATION

Insert (2x) minimum grade 8.8 steel M12x25mm bolts (not included) through the respective mounting hole of the clamp (not included), and then thread it into the matching 12M holes on the bottom of the fixture base. Both bolts must be threaded at least 18mm (0.7ins) into the fixture base.

(2xM12) Threaded Holes,  
max. Screw length 19mm

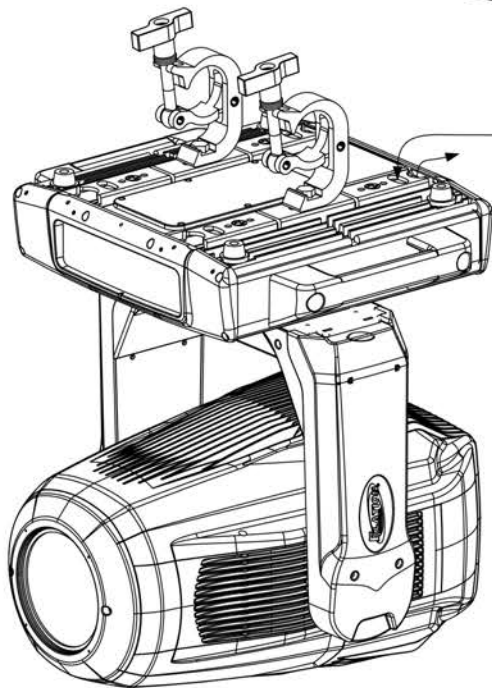
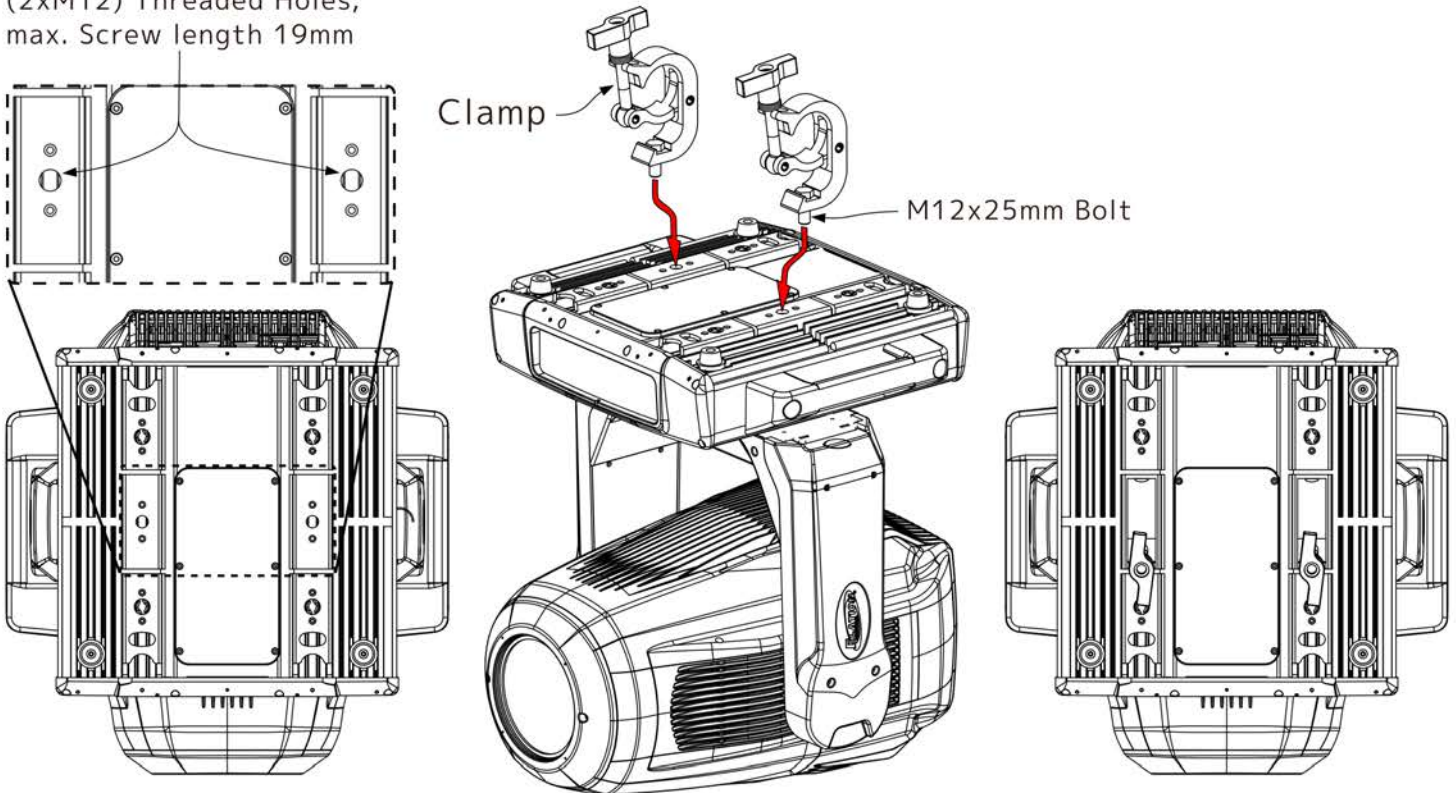

Route Safety Cable through  
Safety Cable Attachment  
Points and around truss

## MOUNTING THE FIXTURE ON A TRUSS USING CLAMPS

When mounting the fixture to a truss, be sure to secure an appropriately rated professional grade rigging clamp to the bottom of the fixture using (2x) minimum grade 8.8 steel (2x) M12x25mm bolts fitted through the mounting hole of the Clamp. The fixture provides built-in rigging points for a SAFETY CABLE (not included). Be sure to only use one of the designated rigging points for the safety cable and never secure a safety cable to a carrying handle.

# INSTALLATION GUIDELINES

## RIGGING

Overhead rigging requires extensive experience, including among others calculating working load limits, installation material being used, and periodic safety inspection of all installation material and the fixture. If you lack these qualifications, do not attempt the installation yourself. Improper installation can result in bodily injury.

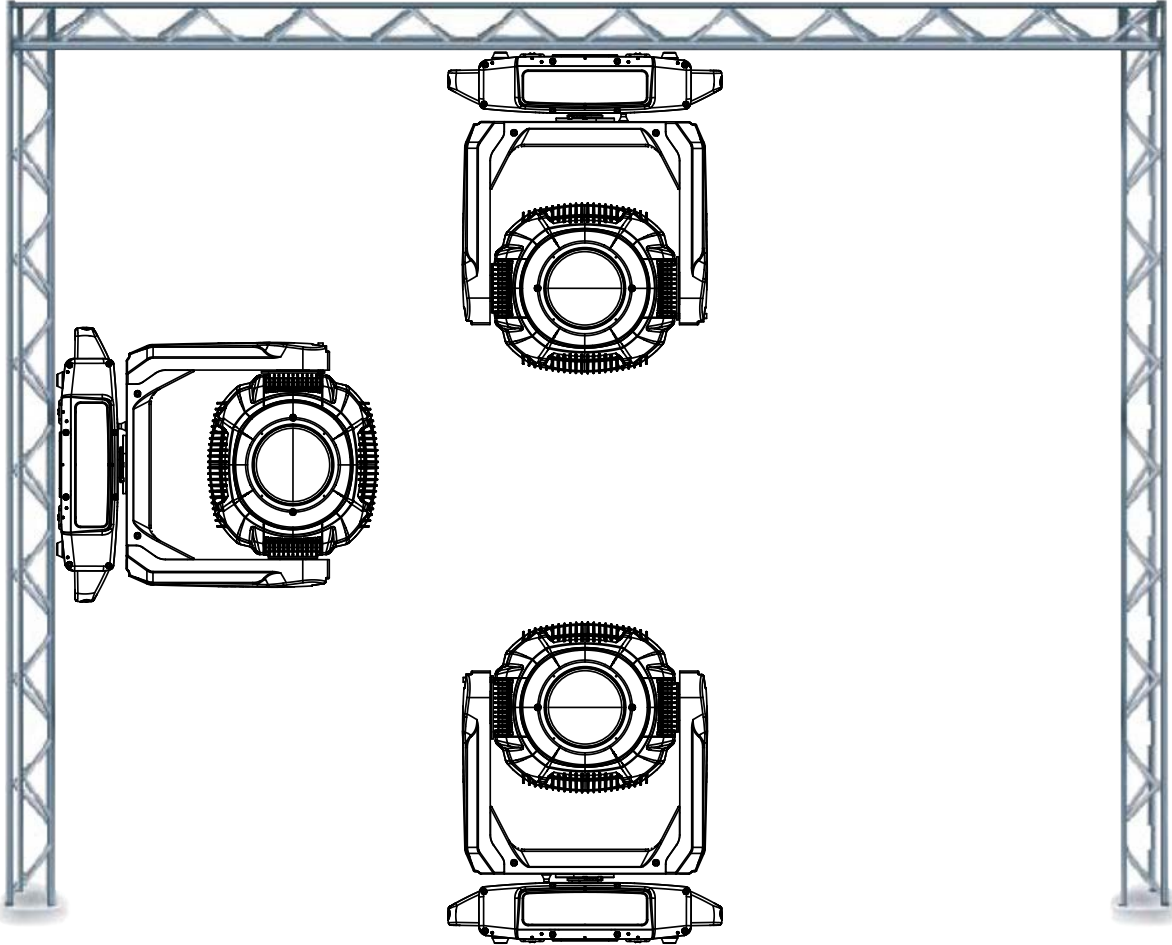

**FALLING FIXTURES CAN CAUSE SEVERE INJURY OR SERIOUS EQUIPMENT DAMAGE! FOR THIS REASON, FIXTURES SHOULD BE INSTALLED AND INSPECTED ONLY BY QUALIFIED PERSONNEL. DO NOT INSTALL THE UNIT IF YOU LACK THE QUALIFICATIONS TO DO SO, OR IF YOU HAVE DOUBTS ABOUT THE SAFETY AND SECURITY OF THE INSTALLATION SETUP OR LOCATION!**



**ALWAYS ATTACH A SAFETY CABLE WHENEVER INSTALLING THIS FIXTURE IN A SUSPENDED ENVIRONMENT TO ENSURE THE FIXTURE WILL NOT FALL IF THE CLAMP FAILS.**

## ART-NET | sACN CONNECTION

When connecting fixture to a network switch to control multiple devices, a Gigabit Ethernet Switch that supports IGMP (Internet Group Management Protocol) is required. Using a Gigabit Ethernet Switch that does not support IGMP can cause erratic behavior of all connected devices to the switch. Click link below for more information about IGMP.

[https://en.wikipedia.org/wiki/Internet\\_Group\\_Management\\_Protocol](https://en.wikipedia.org/wiki/Internet_Group_Management_Protocol).

# INSTALLATION GUIDELINES

## POTENTIAL INTERNAL FIXTURE DAMAGE FROM EXTERNAL SOURCES OF LIGHT BEAMS

External sources of light beams from direct sunlight, lighting moving head fixtures, and lasers, which are focused directly towards the exterior housing and/or penetrate the front lens opening of ELATION lighting fixtures, can cause severe internal damage including burning to optics, dichroic color filters, glass and metal gobos, prisms, animation wheels, frost filters, iris, shutters, motors, belts, wiring, discharge lamps, and LEDs.

This issue is not specific only to ELATION lighting fixtures, it is a common issue with lighting fixtures from all manufacturers. Although there is no true way to fully prevent this issue from happening, the guidelines below can prevent any potential damage from occurring if followed. Contact ELATION Service for more details.

**DO NOT EXPOSE THE FIXTURE AND/OR FRONT LENS OPENING TO LIGHT BEAMS FROM DIRECT SUNLIGHT, OTHER LIGHTING MOVING HEAD FIXTURES, AND LASERS WHILE UNPACKING, INSTALLATION, USE, AND EXTENDED IDLE TIMES OUTDOORS. DO NOT FOCUS A LIGHT BEAM FROM ONE LIGHTING FIXTURE DIRECTLY TOWARDS ANOTHER.**

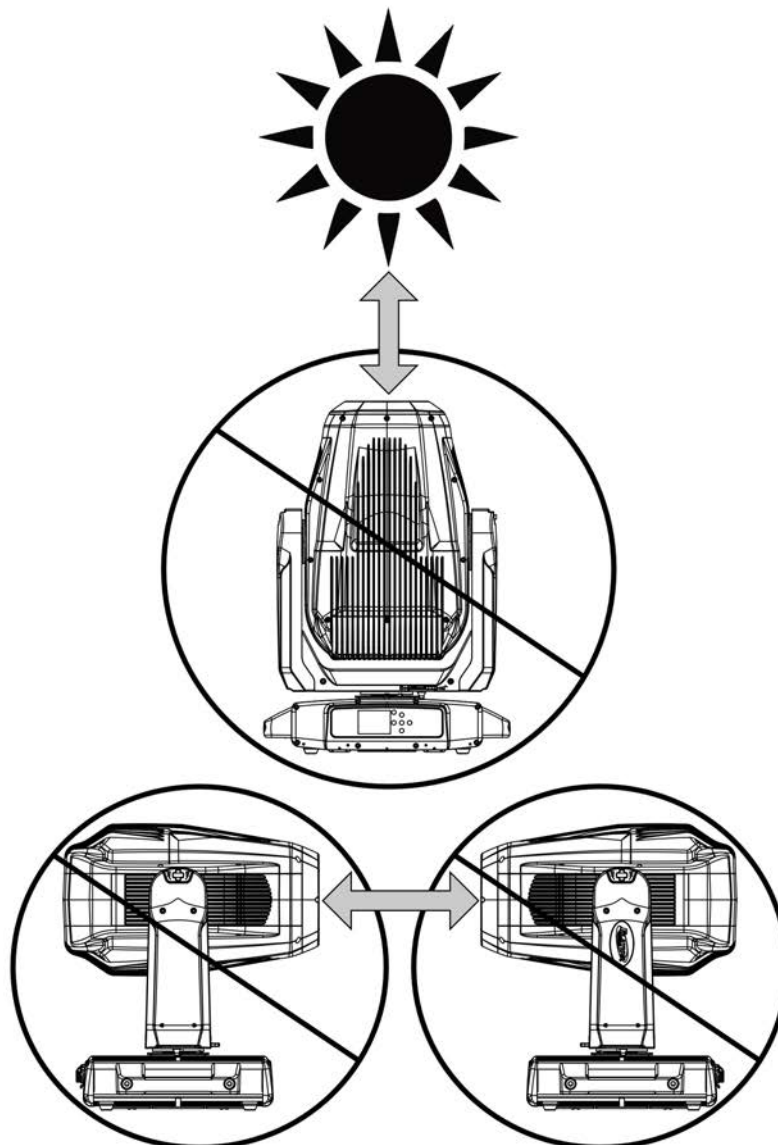

# SUN PROTECTION MODE

The fixture incorporates an automatic protection from harmful sunlight, which can damage a fixture's internal components from extended exposure. Fixtures use an internal sensor to determine their physical orientation, then reorient the fixture towards the ground to prevent sunlight from entering the lens.

This automatic feature only works when the fixture is powered. If the fixture is unpowered during setup, it is necessary to manually reorient the lenses away from the sun, and aim them towards the ground. Even a few minutes of sun exposure can cause damage inside the fixture.

The Sun Protection setting is accessed via the "No DMX Status" menu.

The automatic sun protection positioning is activated under the following conditions:

1. Power on without DMX signal: the fixture always starts in sun protection mode.
2. No DMX Status "Sun Protection": the fixture enters sun protection mode after approximately 3 minutes.
3. Remote DMX control: the sun protection position can be **temporarily** activated from the lighting console without the need to create a custom position preset. The fixture senses the correct ground orientation. This means that fixtures already facing the ground may not move their heads.

Hold "Sun Protect Position" for 3s to set the fixture to the sun protection position.

Sun protection status displays as "**Sun Protection: Active**".

The sun protection position deactivates under the following conditions:

1. Connect DMX signal.
2. Remote DMX control: Hold "Sun Protection Off" for 3s.

To avoid harsh or jarring movements, the sun protection position always uses a 5-second fade time when it is activated or deactivated.

# HIBERNATION MODE

To reduce wear on the fixture and its components, this mode disables motors and most electronics. Set the hibernation mode countdown time in the Display Menu: "Status Settings / Personality / Hibernation". Hibernation can be fully disabled.

The hibernation mode activates under the following conditions:

1. Loss of DMX: the fixture enters hibernation after the timeout expires. Default is 15 minutes.
2. Remote DMX control: Hold "Hibernate Fixture" for 3s

The hibernation mode deactivates under the following conditions:

1. Connect DMX Signal
2. Remote DMX control: Hold "Hibernate Off" for 3s

The fixture will perform a full calibration cycle, then assume the current DMX status.

Please note that the Hibernation does not change the PT position of the fixtures, allowing the user to set the desired position and then issue the Hibernate command.

To ensure the fixture is protected from harmful sunrays it is recommended to either leave the "No DMX Status" in "Sun Protection" (so the fixture is already in the correct position after 3 minutes of DMX loss) or set the fixture to a safe Tilt position manually first before hibernation.

**Burn and heat damage to the fixture's interior components due to external light sources (sun or other fixtures shining into the lens) is never covered under the manufacturers warranty.**

# SYSTEM MENU

The fixture includes an easy to navigate system menu. The control panel (see image below) located on the front of the fixture, provides access to the main system menu and is where all necessary system adjustments are made to the fixture. During normal operation, pressing **MODE/ESC** button once will access the fixture’s main menu. Once in the main menu you can navigate through the different functions and access the sub-menus with the **UP, DOWN, RIGHT,** and **LEFT** buttons. Once you reach a field that requires adjusting, press the **ENTER** button to activate that field and use the **UP** and **DOWN** buttons to adjust the field. Pressing the **ENTER** button once more will confirm your setting. You may exit the main menu at any time without making any adjustments by pressing the **MODE/ESC** button.

**Note: The Display is only activated by way of DMX, NFC, or the Aria app.**

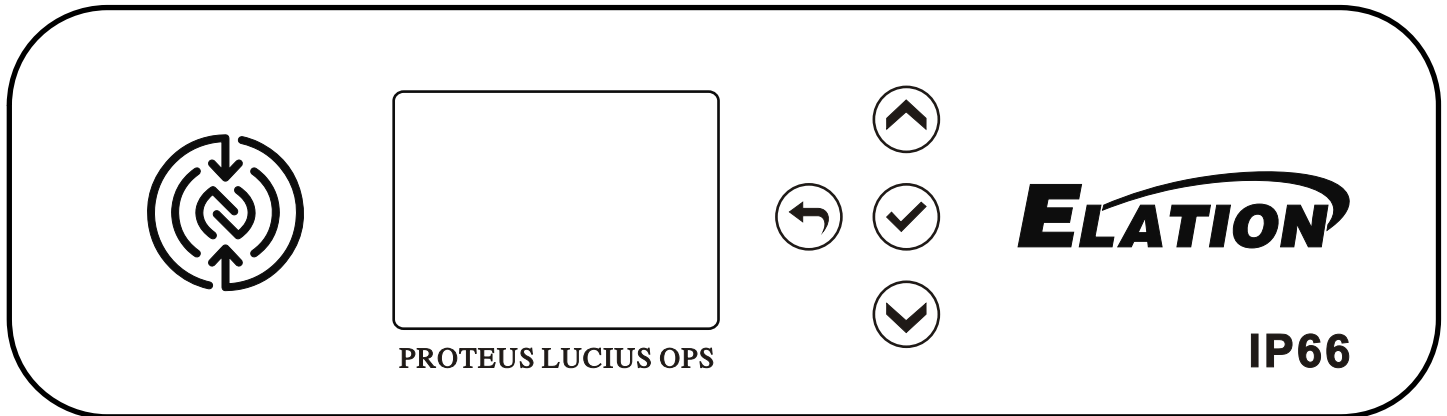

**The display never turns on unless explicitly activated by NFC or DMX**

	Display	*LED
Power On	Off	Green, turn off after 5 min
Reset	Off	Green, turn off after 5 min
Display enable (NFC or DMX)	On	Green
Error Detected	Off	Red, never turn off
Hibernate	Off	Orange
Hibernate Resume	Off	Green, turn off after 5 min

**Note:** the INDICATOR LIGHTS LED is located on the rear panel (see Overview on page 9).

## ARIA ACTIVATION AND SOFTWARE UPDATE

Although Aria settings may appear in the System Menu, the optional Aria wireless DMX feature is not activated and requires activation in the Service Menu. To activate Aria or update the Elation Proteus Lucius OPS fixture to the latest software, contact Elation Service:

**Elation Service USA:** Monday - Friday, 8:00 AM to 4:30 PM PST



+1 323-582-3322 | support@elationlighting.com

**Elation Service Europe:** Monday - Friday, 08:30 to 17:00 CET

+31 45 546 85 63 | support@elationlighting.eu

**Note:** Aria wireless software updates are not currently available. Do not attempt to use Aria for updates without Elation’s guidance. Ensure stable power (AC 100-240V, 50/60Hz) during any update process.

# SYSTEM MENU

MAIN MENU	OPTIONS / VALUES (Default Settings in <b>BOLD</b> )		
DMX	DMX Address	<b>001</b> - 512	
	DMX Mode	<b>Standard</b> , Extended	
	No DMX Status	<b>Hold Last</b> , Fade to Black, Sun Protection	
		Hibernation	Off, 1-99M ( <b>Default=15Min</b> )
	Protocol	Select Signal	<b>DMX</b> / Aria In-DMX Out / DMX In - Aria Out
	Aria	Enable Aria	<b>Off/On</b>
		Frequency	<b>2.4Ghz</b> / Sub Gig-US / Sub Gig-EU
		2.4Ghz Chan	<b>0</b> -15
		Sub Gig Chan	<b>0</b> -9
Enable Mesh		<b>Off/On</b>	
	Enable Bluetooth	Off/ <b>On</b>	
CONTROL	Manual Control	Dimmer 0% - <b>100%</b> , Pan, Tilt, ...	
	Reset	All, Pan Tilt, Color, Gobo, Focus Zoom, Others	
	Self Test	All, Dimmer, Movement, Color Mix, Gobo, Beam	
SETTINGS	Movement	Pan Invert	<b>Off/On</b>
		Tilt Invert	<b>Off/On</b>
		Pan Tilt Speed	<b>Fast/Smooth</b>
		Pan Tilt Brake	<b>Smooth/Fast</b>
		Pan Tilt Feedback	Off/ <b>On</b>
		Gobo Color Cor.	Disable/ <b>Enable</b>
		FollowSpot Mode (default hidden.)	<b>Off/On/Close Menu</b>
	Fans Control	<b>Auto</b> , High, Low, Studio, Mute	
	Color	CMY Speed	Smooth/ <b>Fast</b>
	Dimmer	<b>Linear</b> , Square, Square Inverse, S-Curve	
	Display	Screen Delay	10s - 5min (Default = <b>1 min</b> )
		Screen Lock	<b>Off</b> , 10s - 5 min
		Auto Rotate	Off/ <b>On</b>
Activate LCD		Off/ <b>On</b>	
Reset Defaults	Yes / No		
INFORMATION	Time	Current Time, Total Run Time, Last Run Time	
	Temperature	Head, Base, Lamp	
	Humidity	Head, Base	
	Fan	Fan 1U (Position), Fan 1U (Position)	
	DMX Values	Pan, Tilt, ...	
	Product IDs	RDM UID	
	Error Logs	Fixture Errors	
	Software Version	Vx.x	
Service (Passcode=050)	Calibration	Dimmer, Pan, Tilt, ...	
	Reset Last Run	Yes / No	
	Reset Error Logs	Yes / No	

DISPLAY SHORTCUTS	
Button Sequence	Function
Press and hold ENTER for 10s	Unlock display (fixture shows 10 second countdown)
Press and hold UP + DOWN for 3s	Disable Pan/Tilt
Press and hold BACK + ENTER for 10s	Reset to Default (Yes to reset, No to cancel and return to menu)

# DIMMER CURVES

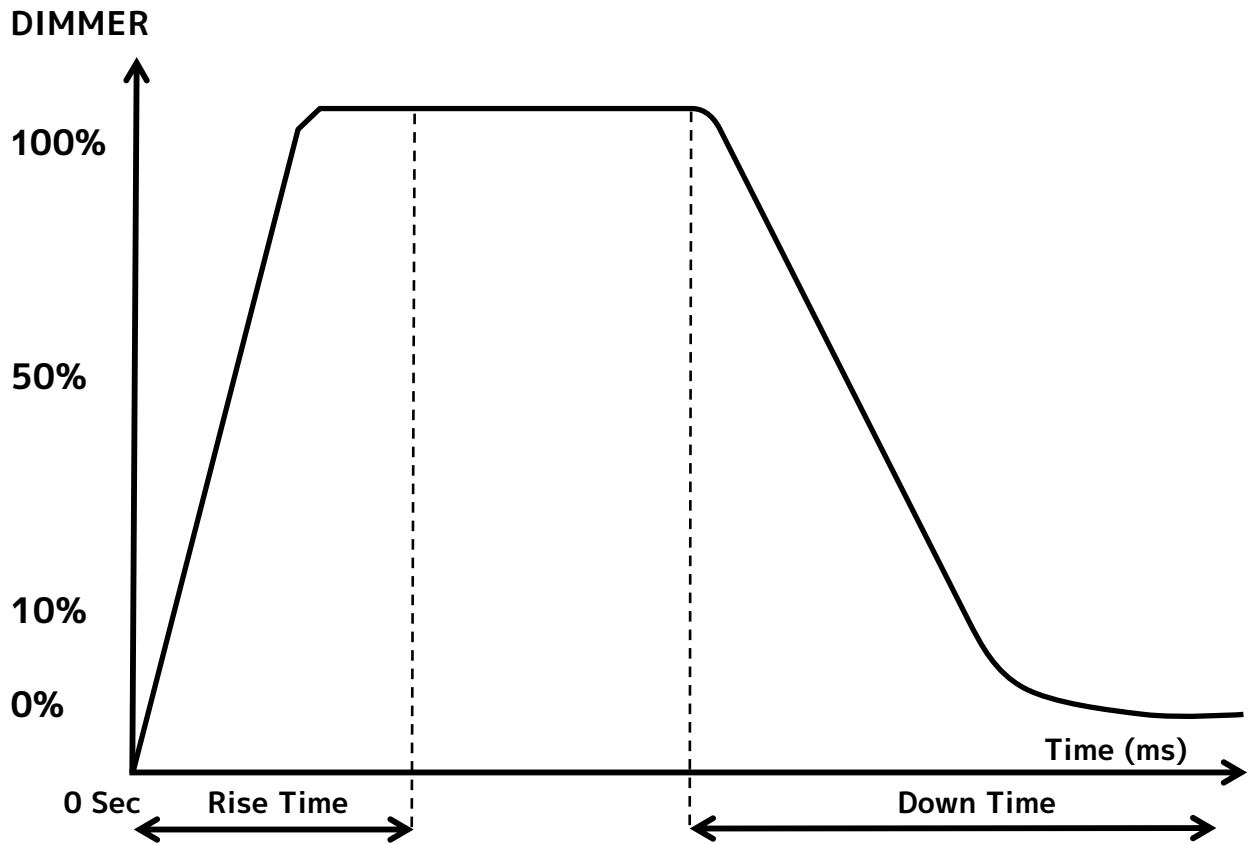

Dimming Curve Ramp Effect	0 sec Fade Time		1 sec Fade Time	
	Rise Time (ms)	Down Time (ms)	Rise Time (ms)	Down Time (ms)
Standard (default)	0	0	0	0
Stage	780	1100	1540	1660
TV	1180	1520	1860	1940
Architectural	1380	1730	2040	2120
Theatre	1580	1940	2230	2280
Stage 2	0	1100	0	1660

# DIMMER MODES

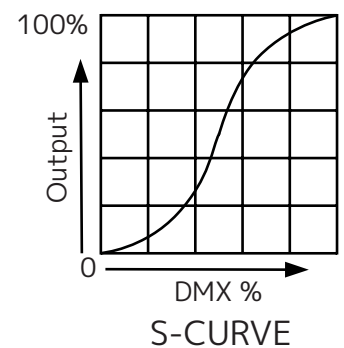
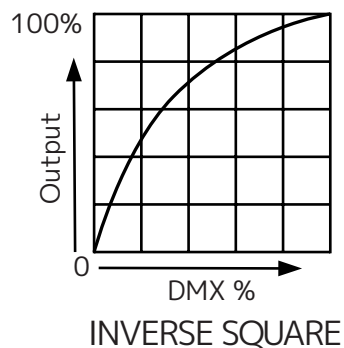
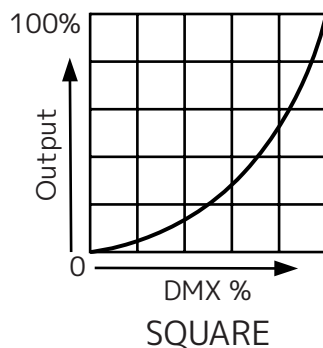
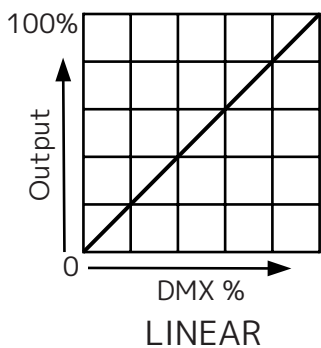

# DMX TRAITS

Features subject to change without notice					
MODE/CHANNEL		VALUE	FUNCTION	SNAP	DEFAULT
STANDARD	EXTENDED				
1	1	0-255	<b>Pan</b> Left → Right		127
2	2	0-255	<b>Pan Fine</b> Fine Position		127
3	3	0-255	<b>Tilt</b> Forward → Backward		127
4	4	0-255	<b>Tilt Fine</b> Fine Position		127
5	5	0-255	<b>Cyan</b> Cyan( 0 → 100%)		0
	6	0-255	<b>Cyan Fine</b> Fine Saturation		0
6	7	0-255	<b>Magenta</b> Magenta( 0 → 100%)		0
	8	0-255	<b>Magenta Fine</b> Fine Saturation		0
7	9	0-255	<b>Yellow</b> Yellow( 0 → 100%)		0
	10	0-255	<b>Yellow Fine</b> Fine Saturation		0
8	11	0-255	<b>CTO</b> Cold → Warm		0
	12	0-255	<b>CTO Fine</b> Fine Saturation		0
9	13		<b>Color</b>	X	0
		0-7	Open		
		8-31	Red		
		32-55	Green		
		56-79	High CRI		
		80-103	Orange		
		104-127	Medium Blue		
			<b>Scroll</b>		
		128-189	Clockwise Fast → Slow		
190-193	Stop				
	194-255	Counter-clockwise Slow → Fast			
	14	0-255	<b>Color Fine</b> Position	X	0

# DMX TRAITS

Features subject to change without notice					
MODE/CHANNEL		VALUE	FUNCTION	DEFAULT	SNAP
STANDARD	EXTENDED				
10	15		<b>Rotating Gobo 1</b>	X	0
		0-9	Open		
		10-19	Gobo 1		
		20-29	Gobo 2		
		30-39	Gobo 3		
		40-49	Gobo 4		
		50-59	Gobo 5		
		60-69	Gobo 6		
		70-89	Gobo 1 shake slow to fast		
		90-109	Gobo 2 shake slow to fast		
		110-129	Gobo 3 shake slow to fast		
		130-149	Gobo 4 shake slow to fast		
		150-169	Gobo 5 shake slow to fast		
		170-189	Gobo 6 shake slow to fast		
			<b>Scroll</b>		
190-221	Clockwise Fast → Slow				
222-223	Stop				
224-255	Counter-clockwise Slow → Fast				
11	16		<b>Rotating Gobo 1 Index/ Rotation</b>		0
		0-127	Index Position		
			<b>Rotate</b>		
		128-189	Clockwise Fast → Slow		
		190-193	Stop		
194-255	Counter-clockwise Slow → Fast				
12	17	0-255	<b>Rotating Gobo Index/ Rotation Fine</b> Index Position		0
13	18		<b>Rotating Gobo 2</b>	X	0
		0-9	Open		
		10-19	Gobo 1		
		20-29	Gobo 2		
		30-39	Gobo 3		
		40-49	Gobo 4		
		50-59	Gobo 5		
		60-69	Gobo 6		
		70-77	Gobo 7		
		78-93	Gobo 1 shake slow to fast		
		94-109	Gobo 2 shake slow to fast		
		110-125	Gobo 3 shake slow to fast		
		126-141	Gobo 4 shake slow to fast		
		142-157	Gobo 5 shake slow to fast		
		158-173	Gobo 6 shake slow to fast		
174-189	Gobo 7 shake slow to fast				
	<b>Scroll</b>				
190-221	Clockwise Fast → Slow				
222-223	Stop				
224-255	Counter-clockwise Slow → Fast				
14	19		<b>Rotating Gobo 2 Index/ Rotation</b>		0
		0-127	Index Position		
			<b>Rotate</b>		
		128-189	Clockwise Fast → Slow		
		190-193	Stop		
194-255	Counter-clockwise Slow → Fast				
15	20	0-255	<b>Rotating Gobo 2 Index/ Rotation Fine</b> Index Position		0

# DMX TRAITS

Features subject to change without notice					
MODE/CHANNEL		VALUE	FUNCTION	DEFAULT	SNAP
STANDARD	EXTENDED				
16	21		<b>Fixed Gobo</b>	X	0
		0-9	Open		
		10-19	Gobo 1		
		20-29	Gobo 2		
		30-39	Gobo 3		
		40-49	Gobo 4		
		50-59	Gobo 5		
		60-69	Gobo 6		
		70-77	Gobo 7		
		78-93	Gobo 1 shake slow to fast		
		94-109	Gobo 2 shake slow to fast		
		110-125	Gobo 3 shake slow to fast		
		126-141	Gobo 4 shake slow to fast		
		142-157	Gobo 5 shake slow to fast		
		158-173	Gobo 6 shake slow to fast		
		174-189	Gobo 7 shake slow to fast		
			<b>Scroll</b>		
		190-221	Clockwise Fast → Slow		
222-223	Stop				
224-255	Counter-clockwise Slow → Fast				
	22	0-255	<b>Fixed Gobo Fine</b> Position		0
17	23		<b>Rotating Prism 1</b>	X	0
		0-63	Open		
		64-127	4-Facet		
		128-135	Macro1		
		136-143	Macro2		
		144-151	Macro3		
		152-159	Macro4		
		160-167	Macro5		
		168-175	Macro6		
		176-183	Macro7		
		184-191	Macro8		
		192--199	Macro9		
		200-207	Macro10		
		208-215	Macro11		
		216-223	Macro12		
		224-231	Macro13		
232-239	Macro14				
240-247	Macro15				
248-255	Macro16				
18	24		<b>Rotating Prism 1 Index/Rotation</b>		0
		0-127	Index Position		
			<b>Rotate</b>		
		128-189	Clockwise Fast → Slow		
		190-193	Stop		
194-255	Counter-clockwise Slow → Fast				
	25	0-255	<b>Rotating Prism 1 Index/Rotation Fine</b> Position		0

# DMX TRAITS

Features subject to change without notice					
MODE/CHANNEL		VALUE	FUNCTION	DEFAULT	SNAP
STANDARD	EXTENDED				
19	26		<b>Rotating Prism 2</b>	X	0
		0-63	Open		
		64-255	4-Facet		
20	27		<b>Rotating Prism 2 Index/Rotation</b>		0
		0-127	Index Position		
			<b>Rotate</b>		
		128-189	Clockwise Fast → Slow		
		190-193	Stop		
	194-255	Counter-clockwise Slow → Fast			
	28	0-255	<b>Rotating Prism 2 Index/Rotation Fine</b>		0
			Position		
21	29	0-255	<b>Focus</b>		127
			Infinity → Near		
22	30	0-255	<b>Focus Fine</b>		127
			Fine Adjustment		
23	31	0-255	<b>Zoom</b>		127
			Narrow → Wide		
24	32	0-255	<b>Zoom Fine</b>		127
			Fine Adjustment		
	33		<b>Auto Focus</b>		0
		0-4	Auto Focus Off		
		51-100	5m		
		101-150	7.5m		
		151-200	10m		
		201-255	15m		
	34	0-255	<b>AutoFocus Fine</b>		0
			Fine Adjustment		
25	35		<b>Shutter/Strobe</b>	X	50
		0-31	Closed		
		32-63	Open		
		64-95	Strobe Slow → Fast		
		96-127	Open		
		128-159	Pulse-effect		
		160-191	Open		
		192-223	Random strobe Slow → Fast		
224-255	Open				
26	36	0-255	<b>Dimmer</b>		0
			Intensity 0 → 100%		
27	37	0-255	<b>Dimmer Fine</b>		0
			Fine Adjustment		

# DMX TRAITS

Features subject to change without notice					
MODE/CHANNEL		VALUE	FUNCTION	DEFAULT	SNAP
STANDARD	EXTENDED				
28	38		<b>Dim Modes</b>	X	0
		0-20	Standard		
		21-40	Stage		
		41-60	TV		
		61-80	Architectural		
		81-100	Theatre		
		101- 120	Stage 2		
			<b>Dimmer Delay Time</b>		
		121	0s		
		122	0.1s		
		123	0.2s		
		124	0.3s		
		125	0.4s		
		126	0.5s		
		127	0.6s		
		128	0.7s		
		129	0.8s		
		130	0.9s		
		131	1.0s		
		132	1.5s		
		133	2.0s		
		134	3.0s		
		135	4.0s		
		136	5.0s		
137	6.0s				
138	7.0s				
139	8.0s				
140	9.0s				
141	10s				
142 - 255	Idle				
29	39		<b>Iris</b>		0
		0-191	Open → Close		
		192-223	Pulse Closing fast → slow		
		224-255	Pulse Opening slow → fast		
	40	0-255	<b>Iris Fine</b> Fine Adjustment		0
30	41	0 – 255	<b>Frost 1 (Soft)</b>		0
			Open → Max		
31	42	0 – 255	<b>Frost 2 (Wash)</b>		0
			Open → Max		
32	43		<b>Animation Wheel</b>		0
		0-7	Open		
		8-255	Animation Min → Max		
33	44		<b>Animation Index</b>		64
		0-127	Position		
			<b>Scroll</b>		
		128-189	Clockwise Fast → Slow		
		190-193	Stop		
		194-255	Counter-clockwise Slow → Fast		

# DMX TRAITS

Features subject to change without notice					
MODE/CHANNEL		VALUE	FUNCTION	DEFAULT	SNAP
STANDARD	EXTENDED				
	45	0-255	<b>Color Macro Speed</b> Max → Min Speed		0
	46		<b>Color Macros</b>	X	0
		0-31	OFF		
		32-39	Macro1		
		40-47	Macro2		
		48-55	Macro3		
		56-63	Macro4		
		64-71	Macro5		
		72-79	Macro6		
		80-87	Macro7		
		88-95	Macro8		
		96-103	Macro9		
		104-111	Macro10		
		112-119	Macro11		
		120-127	Macro12		
		128-135	Macro13		
		136-143	Macro14		
		144-151	Macro15		
		152-159	Macro16		
		160-167	Macro17		
		168-175	Macro18		
	176-183	Macro19			
	184-191	Macro20			
	192-199	Macro21			
	200-207	Macro22			
	208-215	Macro23			
	216-223	Macro24			
	224-231	Macro25			
	232-239	Macro26			
	240-247	Macro27			
	248-255	Random CMY			
34	47	0-255	<b>Blade 1 A</b> Open → Closed		0
	48	0-255	<b>Blade 1 A Fine</b> Fine Adjustment		0
35	49	0-255	<b>Blade 1 B</b> Open → Closed		0
	50	0-255	<b>Blade 1 B Fine</b> Fine Adjustment		0
36	51	0-255	<b>Blade 2 A</b> Open → Closed		0
	52	0-255	<b>Blade 2 A Fine</b> Fine Adjustment		0
37	53	0-255	<b>Blade 2 B</b> Open → Closed		0
	54	0-255	<b>Blade 2 B Fine</b> Fine Adjustment		0
38	55	0-255	<b>Blade 3 A</b> Open → Closed		0
	56	0-255	<b>Blade 3 A Fine</b> Fine Adjustment		0
39	57	0-255	<b>Blade 3 B</b> Open → Closed		0
	58	0-255	<b>Blade 3 B Fine</b> Fine Adjustment		0

# DMX TRAITS

Features subject to change without notice					
MODE/CHANNEL		VALUE	FUNCTION	DEFAULT	SNAP
STANDARD	EXTENDED				
40	59	0-255	<b>Blade 4 A</b> Open → Closed		0
	60	0-255	<b>Blade 4 A Fine</b> Fine Adjustment		0
41	61	0-255	<b>Blade 4 B</b> Open → Closed		0
	62	0-255	<b>Blade 4 B Fine</b> Fine Adjustment		0
42	63		<b>Framing Rotation</b>		127
		0-126	Min (-45°)		
		127-128	Parallel (0°)		
	64	0-255	<b>Framing Rotation Fine</b> Fine Adjustment		0
	65	0-255	<b>Framing Macro Speed</b> Max → Min Speed		0
			<b>Framing Macro</b>		
	66	0-7	OFF		0
		8-15	Macro1		
		16-23	Macro2		
		24-31	Macro3		
		32-39	Macro4		
		40-47	Macro5		
		48-55	Macro6		
		56-63	Macro7		
		64-71	Macro8		
		72-79	Macro9		
		80-87	Macro10		
		88-95	Macro11		
		96-103	Macro12		
		104-111	Macro13		
		112-119	Macro14		
		120-127	Macro15	X	
		128-135	Macro16		
		136-143	Macro17		
		144-151	Macro18		
		152-159	Macro19		
		160-167	Macro20		
		168-175	Macro21		
		176-183	Macro22		
		184-191	Macro23		
		192-199	Macro24		
		200-207	Macro25		
		208-215	Macro26		
		216-223	Macro27		
		224-231	Macro28		
		232-239	Macro29		
		240-247	Macro30		
	248-255	Macro31			
	67		<b>Pan / Tilt Speed</b>		0
		0-225	Max → Min Speed		
		226-235	Blackout by movement	X	
		236-245	Blackout by wheel changes		
		246-255	No function		

# DMX TRAITS

Features subject to change without notice					
MODE/CHANNEL		VALUE	FUNCTION	DEFAULT	SNAP
STANDARD	EXTENDED				
43	68		<b>Control</b>	X	0
		0-19	Wheel Snap		
		20-29	Color Wheel Fade		
		30-39	Color/Gobo Wheel Fade		
			<b>Fan Mode</b>		
		40-44	Mute		
		45-49	Studio		
		50-59	Low		
		60-69	High		
		70-79	Auto (default)		
			<b>Reset</b>		
		80-84	Fixture		
		85-87	Pan Tilt		
		88-90	Color		
		91-93	Gobo		
		94-96	Focus Zoom		
		97-99	Other Features		
			<b>Refresh Rate (Hz)</b>		
		100	900		
		101	910		
		102	920		
		103	930		
		104	940		
		105	950		
		106	960		
		107	970		
		108	980		
		109	990		
		110	1000		
		111	1010		
		112	1020		
		113	1030		
		114	1040		
		115	1050		
116	1060				
117	1070				
118	1080				
119	1090				
120	1100				
121	1110				
122	1120				
123	1130				
124	1140				
125	1150				
126	1160				
127	1170				
128	1180				
129	1190				
130	<b>1200 (default)</b>				
131	1210				
132	1220				
133	1230				
134	1240				

# DMX TRAITS

Features subject to change without notice					
MODE/CHANNEL		VALUE	FUNCTION	DEFAULT	SNAP
STANDARD	EXTENDED				
43	68	135	1250	X	0
		136	1260		
		137	1270		
		138	1280		
		139	1290		
		140	1300		
		141	1310		
		142	1320		
		143	1330		
		144	1340		
		145	1350		
		146	1360		
		147	1370		
		148	1380		
		149	1390		
		150	1400		
		151	1410		
		152	1420		
		153	1430		
		154	1440		
		155	1450		
		156	1460		
		157	1470		
		158	1480		
		159	1490		
		160	1500		
		161	2500		
		162	4000		
		163	5000		
		164	6000		
		165	10000		
		166	15000		
		167	20000		
		168	25000		
		169-170	Gobo Color Correction disable		
		171-172	Gobo Color Correction enable (default)		
		173-174	Hibernation Off		
		175-176	Hibernation		
		177-178	Sun Protection On (default)		
		179-180	Sun Protection Off		
		181-190	Pan Tilt Smooth		
		191-200	Pan Tilt Fast (default)		
			<b>Dimmer Curve</b>		
		201-210	Linear (default)		
		211-220	Square		
		221-230	Inverse Square		
		231-240	S-Curve		
		241-243	Idle		
244-245	Display Disable (default)				
246-247	Display Enable (1h)				
248-249	Cmy Smooth				
250-251	Cmy Fast (default)				
252-255	Idle				

# REMOTE DEVICE MANAGEMENT (RDM)

**NOTE: In order for RDM to work properly, RDM enabled equipment must be used throughout the entire system, including DMX data splitters and wireless systems.**

Remote Device Management (RDM) is a protocol that sits on top of the DMX512 data standard for lighting, allowing the DMX systems of the device to be managed, modified, and monitored remotely (hence, remote device management). This protocol is ideal for fixtures installed in locations that are not easily accessible.

With RDM, the DMX512 system becomes bi-directional, allowing a compatible RDM enabled controller to send out a signal to devices on the wire, as well as allowing the fixture to respond (known as a GET command). The controller can then use it's SET command to modify settings that would typically have to be changed or viewed directly via the unit's display screen, including the DMX Address, DMX Channel Mode, and Temperature Sensors.

## FIXTURE RDM INFORMATION:

RDM Code	Device ID	Device Model ID	Personality ID
0X667	OPEN	1639	OPEN

**Please be aware that not all RDM devices support all RDM features,** and therefore it is important to check beforehand to ensure that the equipment that you are considering includes all of the features that you require.

The following parameters are accessible in RDM on this device:

LED FIXTURE	
0x0200	Sensor Definition
0x0201	Sensor Value
0x0080	Device Model Description
0x0081	Manufacturer Label
0x0082	Device Label
0x00E0	DMX Personality
0x00E1	DMX Personality Description
0x0400	Device Hours
0x0600	Pan Invert
0x0601	Tilt Invert
0x0500	Display Invert

# ERROR CODES

When power is applied, the unit will automatically enter a "Reset/Test" mode. This mode brings all the internal motors to a home position. If there is an internal problem with one or more of the motors an error code will flash in the display in the form of "XXer" where as XX will represent a function number. For example, when the display shows "0Er" it means there is some type of error with the Pan motor. If there are multiple errors during the start-up process they will all flash in the display. For example: if the fixtures has errors on Channel 1, 2, and 5 all at the same time, you will see the error message "01Er", "02Er", and "05Er" flash repeated 5 times.

If an error does occur during the initial start-up procedure the fixture will self-generate a second reset signal and try to realign all the motors and correct the errors. If the error persists after a second attempt a third attempt will be made. If after a third attempt all the errors have not been corrected the fixture will make the following determinations:

- 3 or More Errors: The fixture cannot function properly with three or more errors therefore the fixture will place itself in a stand-by mode until subsequent repairs can be made.
- Less Than 3 Errors: The fixture has less than 3 errors; therefore, most other functions will work properly. The fixture will attempt to operate normally until the errors can be correct by a technician. The errors in question will remain flashing in the display as a reminder of internal errors.

Error Codes subject to change without notice	
ERROR CODES	DESCRIPTION
Pan Tilt Cyan Megenta Yellow CTO CTB Color Wheel Gobol Gobol_ROT Gobo2 Gobo2_ROT Fixed_Gobo Focus Zoom Prism1 Prism_Rot1 Prism2 Prism_Rot2 Frost1 Frost2 Iris Animation AnimationRot Blade_Rot LED Temp Error Head Temp Error Base Temp Error 3UHeadFan1 Error 3UHeadFan2 Error 3UHeadFan3 Error 3UHeadFan4 Error 3UHeadFan5 Error 5UHeadFan1 Error 8UHeadFan1 Error 11UHeadFan1 Error 11UHeadFan2 Error 11UHeadFan5 Error 11UHeadFan6 Error Base Fan1 Error Base Fan2 Error Base HD Warning. Base HD Higher. Head HD Warning. Head HD Higher. Base HD Error. Head HD Error.	Movement is not located in the default position after the reset. This message will appear after a fixture reset if the magnetic-indexing circuit malfunctions (sensor failed, or magnet is missing) or there is a motor failure (defective motor or a defective motor IC drive on the main PCB).

# MAINTENANCE GUIDELINES

## SPECIALIZED OPS MAINTENANCE

Fixtures in Elation Lighting's OPS Series are high-performance, IP-rated moving light fixtures designed for professional use in extreme conditions. To maintain peak performance and ensure maximized longevity, regular maintenance and proper operational practices are essential. This section provides guidance on maintenance schedules, best practices for cleanliness, and duty cycle recommendations. Please refer all service issues to an authorized Elation service technician. Should you need any spare parts, please order genuine parts from an authorized Elation dealer.

### Weekly Maintenance

- Clean the external housing using a soft cloth with mild detergent.
- Inspect the cooling fans and vents for dust buildup and clean as needed.
- Perform a quick function test (pan, tilt, color, gobo, zoom, focus, etc.).

### Monthly Maintenance

- Inspect and clean the lens assembly with an approved optical-grade lens cleaner.
- Check all moving parts for smooth operation and apply manufacturer-approved lubricants if necessary.
- Inspect gobo wheels, color wheels, and effects for dust accumulation.
- Check firmware versions and update if needed.

### Quarterly Maintenance

- Open fixture housing and inspect for internal dust buildup. Please note that any IP-rated areas must be resealed properly during re-assembly.
- Verify that seals and gaskets maintain IP rating integrity.
- Tighten any loose screws or fasteners.
- Test fixture for proper operation in extreme conditions (if applicable to the environment).

### Annual Maintenance

- Perform a full diagnostic check using the fixture's built-in test functions.
- Disassemble and clean optical components, ensuring all are free of residue or buildup.
- Replace any worn-out gaskets, filters, or seals.
- Perform a full recalibration of pan/tilt and effect mechanisms.
- Check internal power supply and ballast for any irregularities.

### Indicator LEDs

This fixture features an LED light that indicates fixture status as follows:

- Green: Fixture is working normally.
- Blinking Yellow: Fixture is in the process of resetting, or is receiving a software update.
- Red: Fixture is experiencing an error.

# MAINTENANCE GUIDELINES

## BEST PRACTICES FOR CLEANING

To maintain optimal performance and prevent premature damage, adhere to the following guidelines:

### General Cleaning Guidelines

- Always power down the fixture and disconnect the power cord before cleaning.
- Use a soft, lint-free cloth with mild detergent for external surfaces.
- For internal cleaning, use compressed air to remove dust from sensitive areas.
- Avoid using alcohol-based or abrasive cleaners on optical components.

### Lens and Optical Component Care

- Use a microfiber cloth and lens-specific cleaner to remove smudges and dust.
- Avoid touching the lens directly with your fingers, as doing so can leave oil residue on the lens.
- Check for condensation inside the lens and ensure proper ventilation.

### Protecting Against Environmental Damage

- When installed in extreme environments, more frequent maintenance will be required.
- For long-term storage, use protective covers to prevent dust accumulation.
- After use in high humidity environments, ensure the fixture is completely dry before it is packed away for storage or transportation.

## DUTY CYCLE USAGE AND THERMAL MANAGEMENT

Proper usage will maximize the longevity of OPS fixtures, and adhering to duty cycle guidelines helps prevent overheating and component wear.

### Recommended Duty Cycles

- Continuous Operation: OPS fixtures are **NOT** designed for 24/7 operation, and require periodic cooling intervals in high-heat environments. No more than 12 hours per day of operation should be allowed.
- Intermittent Use: When used in show environments with frequent starts/stops, allow for cool-down intervals in order to maintain optimal performance.
- Extreme Weather Use: Ensure fixtures are adequately ventilated and monitored for any excessive moisture ingress.

### Thermal Protection Measures

- Monitor temperature warnings via RDM or NFC Aria X2.
- Ensure unobstructed airflow around the unit.
- If running fixtures in direct sunlight, utilize shading to reduce the thermal impact.

# SPECIFICATIONS

## SOURCE

580W 6,500K Bright White Peak Field LED Engine

30,000 Hour Average LED Life\*

\*Test lab conditions. May vary depending on several factors including but not limited to:

Environmental Conditions, Power/Voltage, Usage Patterns (On-Off Cycling), Control, and Dimming.

## PHOTOMETRIC DATA

33,500 Total Lumen Fixture Output

CRI 71+ (85+ with HCRI Filter)

2.5:1 Hotspot Ratio

Zoom Range 5.5° - 50°

Beam Angle 6° - 36.7°

Field Angle 7.6° - 51.3°

## EFFECTS

Motorized Zoom

4 Rotating Full Blackout Framing Blades

+/-45° Framing Indexing

Full 360° Bi-Directional Animation Wheel

4-Facet and Linear Rotating Prisms

2 Variable Frost Filters (Light and Wash)

Internal Color, Framing, Prism, and Frost Macros

Motorized Iris with Variable Pulse Effects

Variable 16-bit Dimming Curve Modes

High Speed Electronic Shutter and Strobe

DMX Controllable LED Refresh Rate

Pan Angle: 540°/630°

Tilt Angle: 250°

## COLOR

CMY Color Mixing

Linear CTO Color Correction

5 Dichroic Colors including High CRI Filter

## GOBOS

3 Gobo Wheels

6 Rotating Gobo (Wheel #1)

7 Rotating Gobos (Wheel #2)

7 Static Gobos (Wheel #3)

## CONTROL / CONNECTIONS

2 DMX Channel Modes (43/68 Ch.)

DMX and RDM Protocol Support

(6) Button Touch Control Panel

Full Color 180° Reversible LCD Menu Display

NFC Support

10' (3m) DMX In/Out combo cable

10' (3m) Power cable

## SIZE / WEIGHT

Length: 18.41 in (468mm)

Width: 14.6 in (370mm)

Height: 26.8in (682mm)

Center-to-Center Spacing 24.6in (626mm)

Weight: 89.9 lbs. (40.8 kg)

## EXTERIOR FINISH

RAL9016 (custom colors available on request)

CX Extreme Marine Grade Coating

Stainless Steel 316 Fasteners

## ELECTRICAL

AC 100-240V 50/60Hz

Max Power Consumption 1000W

-4° to 122°F (-20°C to 50°C)

BTU/hr (+/- 10%) 3239.5

## INCLUDED ITEMS

Omega Brackets (x2)

Safety Cable

## APPROVALS / RATINGS

CE | cETLus | FCC | IP66



# DIMENSIONS

\*Drawings not to scale.

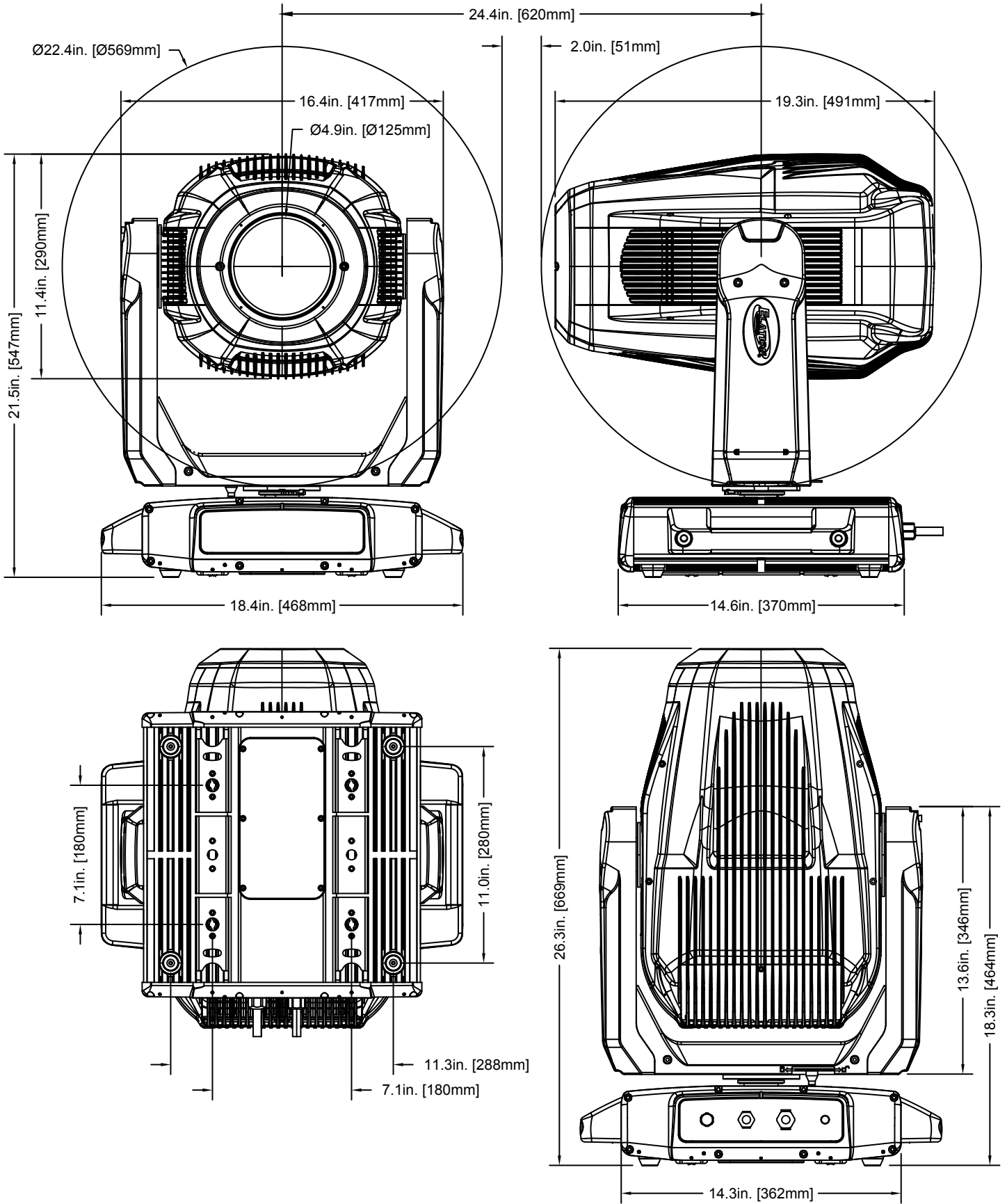

# OPTIONAL ACCESSORIES

ORDER CODE (US)	ORDER CODE (EU)	ITEM
PRL734	N/A	Proteus Lucius OPS
TRIGGER CLAMP	1741000032	Heavy Duty Wrap Around Hook Style Clamp



## FCC STATEMENT

This device complies with Part 15 of the FCC Rules. Operation is subject to the following two conditions: (1) this device may not cause harmful interference, and (2) this device must accept any interference received, including interference that may cause undesired operation.

## FCC RADIO FREQUENCY INTERFERENCE WARNINGS & INSTRUCTIONS

This product has been tested and found to comply with the limits as per Part 15 of the FCC Rules. These limits are designed to provide reasonable protection against harmful interference in a residential installation. This device uses and can radiate radio frequency energy and, if not installed and used in accordance with the included instructions, may cause harmful interference to radio communications. However, there is no guarantee that interference will not occur in a particular installation. If this device does cause harmful interference to radio or television reception, which can be determined by turning the device off and on, the user is encouraged to try to correct the interference by one or more of the following methods:

- Reorient or relocate the device.
- Increase the separation between the device and the receiver.
- Connect the device to an electrical outlet on a circuit different from which the radio receiver is connected.
- Consult the dealer or an experienced radio/TV technician for help.

## Energy Saving Matters (EuP 2009/125/EC)

Saving electric energy is a key to help protecting the environment. Please turn off all electrical products when they are not in use. To avoid power consumption in idle mode, disconnect all electrical equipment from power when not in use. Thank you!

