

ELIMINATOR[®]

LIGHTING

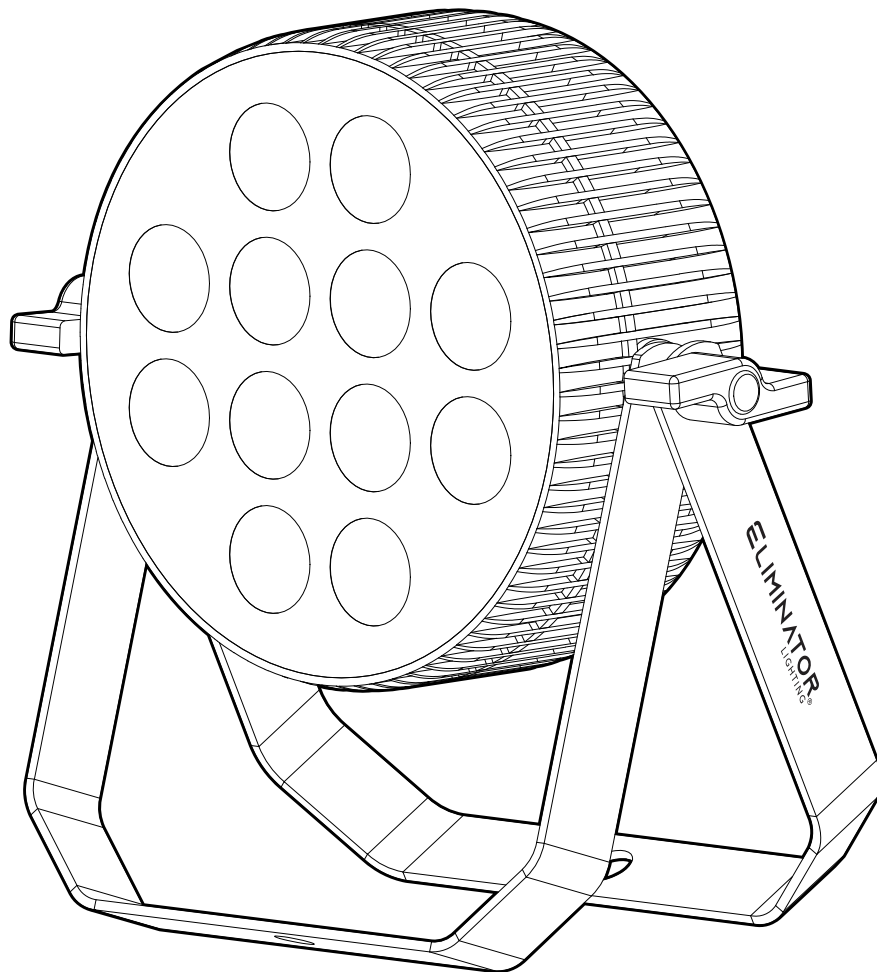

LP HEX 12 PLUS

User Manual

©2026 Eliminator Lighting all rights reserved. Information, specifications, diagrams, images, and instructions herein are subject to change without notice. Eliminator logo and identifying product names and numbers herein are trademarks of Eliminator Lighting. Copyright protection claimed includes all forms and matters of copyrightable materials and information now allowed by statutory or judicial law or hereinafter granted. Product names used in this document may be trademarks or registered trademarks of their respective companies and are hereby acknowledged. All non-Eliminator brands and product names are trademarks or registered trademarks of their respective companies.

Eliminator Lighting and all affiliated companies hereby disclaim any and all liabilities for property, equipment, building, and electrical damages, injuries to any persons, and direct or indirect economic loss associated with the use or reliance of any information contained within this document, and/or as a result of the improper, unsafe, insufficient and negligent assembly, installation, rigging, and operation of this product.

Eliminator Lighting

6122 S. Eastern Ave. Los Angeles, CA. 90040
323-582-2650 | www.adj.com | info@adj.com

ADJ SUPPLY Europe B.V

Junostraat 2 6468 EW Kerkrade, The Netherlands
+31 (0)45 546 85 00 | www.adj.eu | info@adj.eu

ADJ PRODUCTS GROUP Mexico

AV Santa Ana 30 Parque Industrial Lerma, Lerma, Mexico 52000
+52 (728) 282-7070

DOCUMENT VERSION



Due to additional product features and/or enhancements, and updated version of this document may be available online.

Please check www.adj.com for the latest revision/update of this manual before beginning installation and/or programming.

Date	Document Version	Software Version >	DMX Channel Mode	Notes
04/10/26	1.0	1.0.0	10 / 12 Ch	Initial release

CONTENTS

Introduction	4
Features	5
Safety Guidelines	6
Overview	8
Installation	9
System Menu	13
Dimmer Modes and Curves	16
DMX Setup	17
DMX Traits	19
Multi-Unit Power-Linking	20
Maintenance Guidelines Cleaning Troubleshooting	21
Specifications	22
Dimensional Drawings	23
Optional Accessories FCC Statement	24

INFORMATION

INTRODUCTION

Please read and understand the instructions in this manual carefully and thoroughly before attempting to operate this device. These instructions contain important safety and use information.

This product is intended for use by professionally trained personnel only, and is not suitable for private use.

Unpacking

Every device has been thoroughly tested and has been shipped in perfect operating condition. Carefully check the shipping carton for damage that may have occurred during shipping. If the carton is damaged, carefully inspect the device for damage, and be sure all accessories necessary to install and operate the device have arrived intact. In the event damage has been found or parts are missing, please contact our customer support team for further instructions. Please do not return this device to your dealer without first contacting customer support. Please do not discard the shipping carton in the trash. Please recycle whenever possible.

Parts: To purchase parts online visit:

<http://parts.adj.com> (US)

<http://www.adjparts.eu> (EU)

ADJ SERVICE USA - Monday - Friday 8:00am to 4:30pm PST

Voice: 800-322-6337 | support@adj.com

ADJ SERVICE EUROPE - Monday - Friday 08:30 to 17:00 CET

Voice: +31 45 546 85 60 | support@adj.eu

ADJ PRODUCTS LLC USA

6122 S. Eastern Ave. Los Angeles, CA. 90040

323-582-2650 | www.adj.com | info@adj.com

ADJ SUPPLY Europe B.V

Junostraat 2 6468 EW Kerkrade, The Netherlands

+31 (0)45 546 85 00 | www.adj.eu | info@adj.eu

ADJ PRODUCTS GROUP Mexico

AV Santa Ana 30 Parque Industrial Lerma, Lerma, Mexico 52000

+52 (728) 282-7070

LIMITED WARRANTY

For up-to-date warranty information regarding your device, please visit ADJ's warranty information page online or scan the QR codes below.



USA: <https://www.adj.com/pages/warranty-information>



EU: https://www.adj.eu/terms_and_conditions

It is strongly recommended to power the fixture down completely when not in use. Doing so will reduce wear on the fixture due to sustained or extended operational periods, thereby maximizing its operational lifespan.

FEATURES

- 12 × 18 W RGBWA+UV 6-in-1 LEDs for extended color spectrum
- Rich, vibrant output including warm ambers, clean whites, deep reds, and powerful UV effects
- Superior color mixing, smooth blending, and uniform wash coverage
- Ideal for stage lighting, uplighting, dance floors, clubs, and permanent installations
- Two DMX modes: 6-channel (basic) and 10-channel (advanced control)
- White balance adjustment and color-cast correction for precise color accuracy
- Built-in temperature protection for safe, reliable long-term operation
- Multiple operating modes: DMX512, Primary-Secondary, Auto Run, and Sound Active
- 0–100% linear dimming with high-speed synchronous strobe
- Compact, lightweight design for easy transport and installation in tight spaces
- Low power consumption: 110 W maximum draw
- IP20 rating for indoor use

SAFETY GUIDELINES

To ensure smooth operation, it is important to follow all instructions and guidelines in this manual. **Eliminator Lighting, LLC** is not responsible for injury and/or damages resulting from the misuse of these devices due to the disregard of the information printed in this manual. Only qualified and/or certified personnel should perform installation of these devices, and only the original rigging parts included with these devices should be used for installation. Any modifications to these devices and/or the included mounting hardware will void the original manufacturer's warranty and increase the risk of damage and/or personal injury.

CAUTION

HIGH INTENSITY ULTRAVIOLET LIGHT

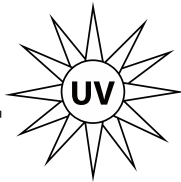

**AVOID DIRECT EYE & SKIN EXPOSURE.
WEAR PROPER EYE & SKIN PROTECTION.
SEE MANUAL FOR SAFETY INSTRUCTIONS.**

RISK GROUP 3 - RISK OF EXPOSURE TO ULTRAVIOLET (UV) RADIATION! FIXTURE EMITS HIGH INTENSITY WAVELENGTH OF ULTRAVIOLET LIGHT AT A WAVELENGTH OF 395NM – 400NM. WEAR PROPER EYE AND SKIN PROTECTION. DO NOT OPERATE FIXTURE WITH DAMAGED/MISSING EXTERNAL COVER PROTECTIVE LENS. DO NOT LOOK DIRECTLY INTO THE (UV) LIGHT AND/OR VIEW (UV) LIGHT DIRECTLY WITH OPTICAL INSTRUMENTS THAT MAY CONCENTRATE THE LIGHT/RADIATION OUTPUT. AVOID PROLONGED PERIODS OF EXPOSURE. AVOID WEARING WHITE COLOR CLOTHING AND/OR USING (UV) PAINTS ON SKIN. AVOID DIRECT EYE AND/OR SKIN EXPOSURE AT DISTANCES SHORTER THAN 11 feet (3.3m). INDIVIDUALS SUFFERING FROM A RANGE OF EYE CONDITIONS, SUNLIGHT EXPOSURE DISORDERS, OR INDIVIDUALS USING PHOTSENSITIVE MEDICATION, MAY RECEIVE DISCOMFORT IF EXPOSED TO THE ULTRAVIOLET (UV) LIGHT EMITTED FROM THIS FIXTURE.



THERE ARE NO USER SERVICEABLE PARTS INSIDE THESE DEVICES. DO NOT ATTEMPT ANY REPAIRS YOURSELF, AS DOING SO WILL VOID YOUR MANUFACTURER'S WARRANTY. DAMAGES RESULTING FROM MODIFICATIONS TO THESE DEVICES AND/OR THE DISREGARD OF SAFETY INSTRUCTIONS AND GUIDELINES IN THIS MANUAL VOID THE MANUFACTURER'S WARRANTY AND ARE NOT SUBJECT TO ANY WARRANTY CLAIMS AND/OR REPAIRS.



**NEVER TOUCH LIGHT DURING OPERATION, AS IT MAY BE HOT!
ALWAYS DISCONNECT FROM MAIN POWER BEFORE PERFORMING ANY REPAIRS OR MAINTENANCE!
ALWAYS REPLACE LAMPS AND FUSES WITH REPLACEMENTS OF THE SAME TYPE!
KEEP FLAMMABLE MATERIALS AWAY FROM THESE DEVICES!**



**INDOOR / DRY LOCATIONS USE ONLY!
DO NOT EXPOSE DEVICES TO RAIN AND/OR MOISTURE!**

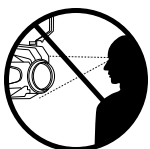

**NEVER LOOK DIRECTLY INTO THE LIGHT SOURCE!
RETINA INJURY RISK - MAY INDUCE BLINDNESS!
SENSITIVE PERSONS MAY SUFFER AN EPILEPTIC SHOCK!**

SAFETY GUIDELINES

DO NOT position devices close to any FLAMMABLE MATERIALS while operating.

DO NOT attempt installation and/or operation of devices without knowledge of how to do so.

DO NOT permit operation by persons who are not qualified to operate these types of devices.

DO NOT shake devices, avoid brute force when installing and/or operating.

DO NOT operate these devices if the main power cord has become frayed, crimped and/or damaged. Replace any damaged power cords with cords of a similar power rating.

DO NOT remove or break off the ground plug from the device power cords.

DO NOT remove or disassemble devices, there are NO user serviceable parts inside.

ALWAYS disconnect devices from main power source before performing any cleaning.

ALWAYS disconnect light from main power before replacing lamp.

ALWAYS be sure to install these devices in an area that will allow proper ventilation.

NEVER remove the ground prong from the power cable.

Power cords should be safely routed and secured so they are not likely to get pinched.

Disconnect power cords during long periods of non-use.

Only use recommended rigging hardware as described in this guide.

Use the original packaging and materials to transport these devices for service.

These devices should be serviced by qualified service personnel when:

- The power cords or plugs have become damaged.
- Objects have fallen on and/or liquid has spilled into the devices.
- The devices have been exposed to rain and/or moisture.
- The devices do not operate normally or exhibit a marked change in performance.

OVERVIEW

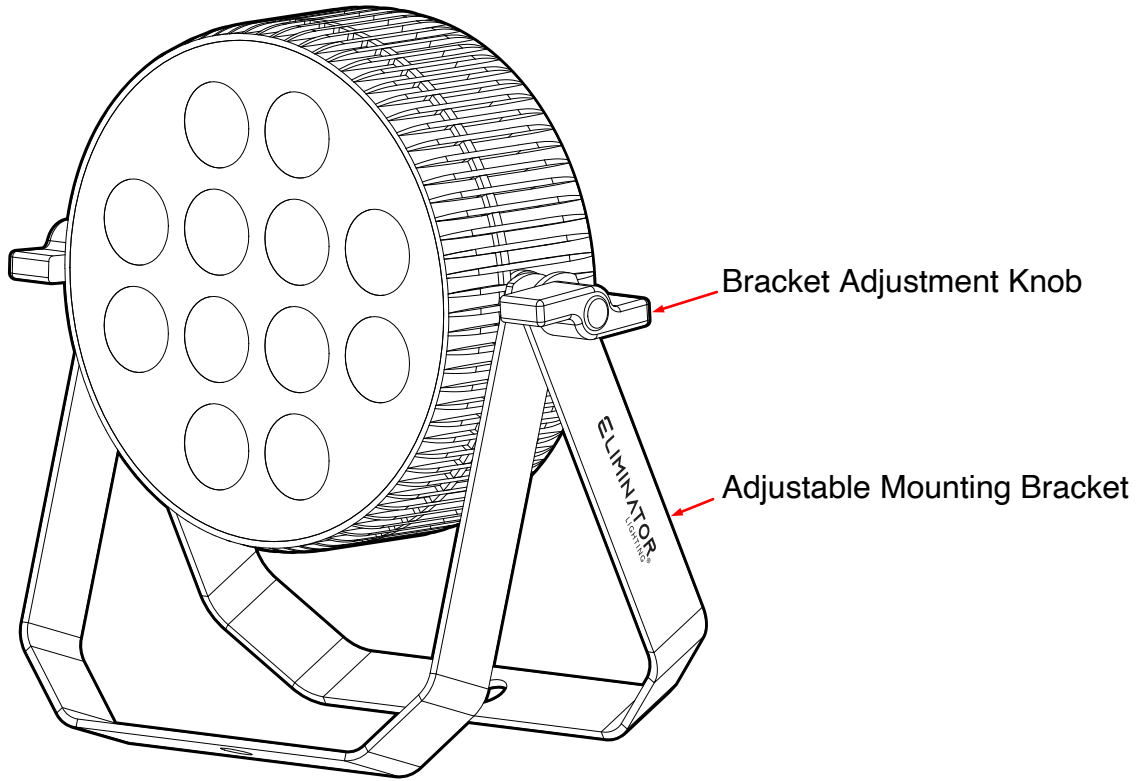

LED Screen

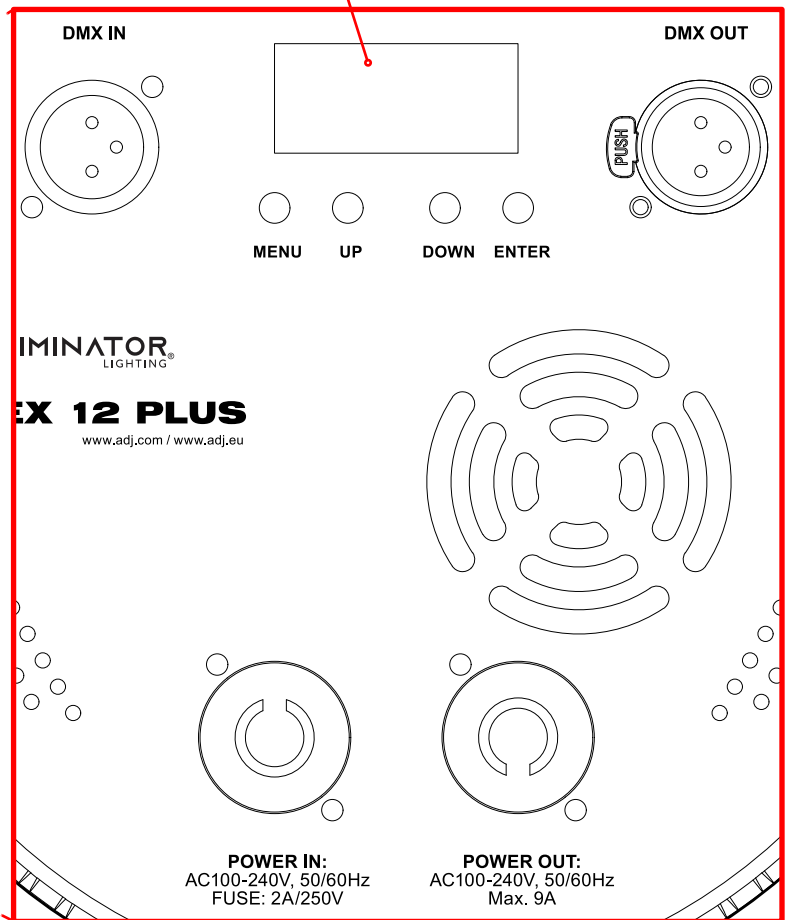
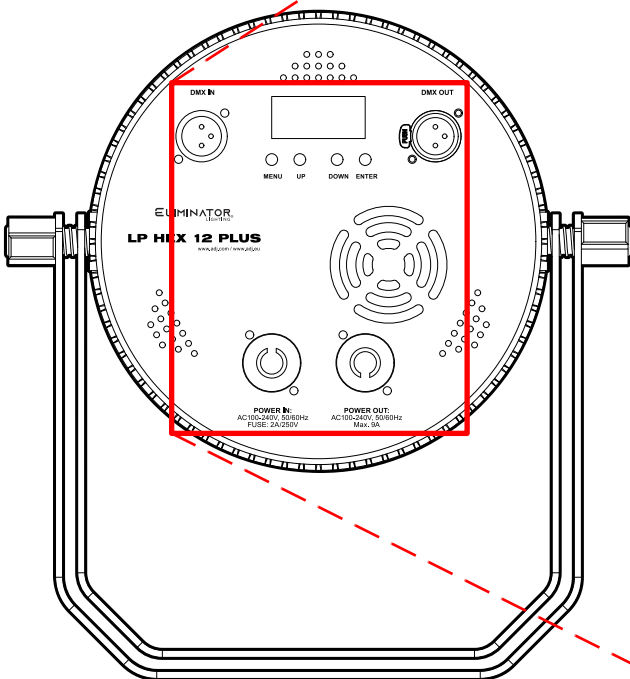

INSTALLATION



FLAMMABLE MATERIAL WARNING

Keep fixture minimum 3.3 ft (1 m) away from flammable materials and/or pyrotechnics.



ELECTRICAL CONNECTIONS

A qualified electrician should be used for all electrical connections and/or installations.



MINIMUM DISTANCES:

- Minimum distance to objects/surfaces: **1.6 ft (0.5 m)**
- Minimum distance to illuminated objects: **1.6 ft (0.5 m)**
- Minimum distance of flammable materials from fixture surface: **3.3 ft (1 m)**



DEVICE IS INTENDED FOR INDOOR USE ONLY! Outdoor installation or exposure to rain or moisture can damage the device and void the manufacturer's warranty.

DO NOT INSTALL THE FIXTURE IF YOU ARE NOT QUALIFIED TO DO SO!

- Fixture **MUST** be installed following all local, national, and country commercial electrical and construction codes and regulations.
- Before rigging/mounting the fixture to any metal truss/structure or placing the fixture on any surface, a professional equipment installer **MUST** be consulted to determine if the metal truss/structure or surface is properly certified to safely hold the combined weight of the fixture, clamps, cables, and accessories.
- Fixture ambient operating temperature range is **-4°F to 113°F (-20°C to 45°C)**. Do not operate this fixture outside this temperature range.
- Fixture should be installed away from walking paths, seating areas, or areas where unauthorized personnel might reach the fixture by hand.
- **NEVER** stand directly below the fixture when rigging, removing, or servicing.
- Overhead fixture installation must always be secured with a secondary safety attachment, such as an appropriately rated safety cable.
- Allow approximately 15 minutes for the fixture to cool down before servicing.

RIGGING

Overhead rigging requires extensive experience, including calculating working load limits, knowledge about installation materials being used, and periodic safety inspection of all installation material and the fixture. If you lack these qualifications, do not attempt the installation yourself. Improper installation can result in bodily injury.

OPERATIONAL BREAKS

Duty Cycle – It is strongly recommended to power the fixture down completely when not in use. Doing so will reduce wear on the fixture due to sustained or extended operational periods, thereby maximizing the fixture's operational lifespan.

INSTALLATION

CLAMP INSTALLATION

This fixture features mounting clamp attachment point. Attach safety cable loop as shown in the illustration below. When mounting the fixture to a truss or any other suspended or overhead installation, be sure to secure an appropriately rated clamp (**not included**) to the clamp attachment point and attach a separate **SAFETY CABLE** of the appropriate safety rating to the safety cable rigging point.

Truss Clamp

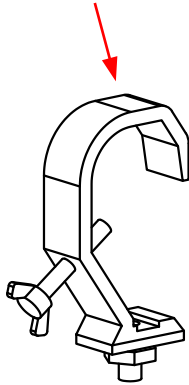

Safety Cable

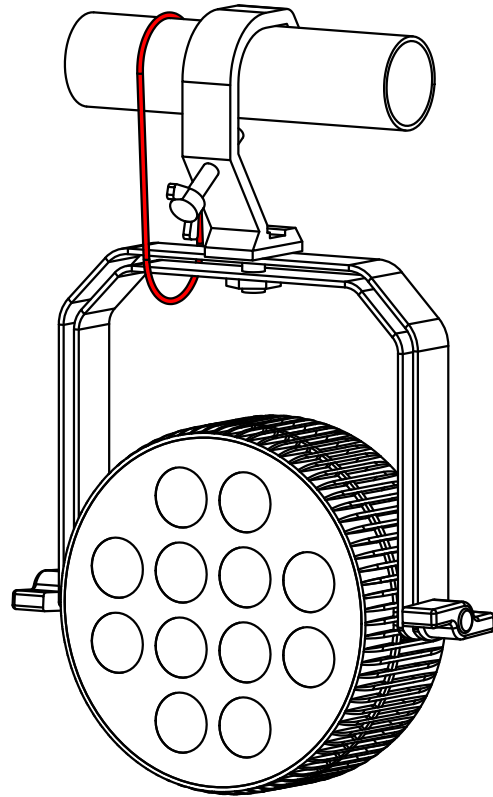
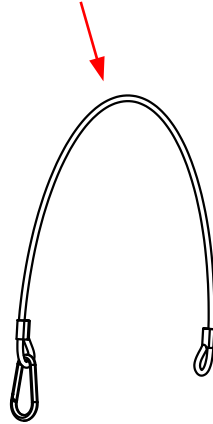

SAFETY CABLE
ALWAYS ATTACH AN APPROPRIATELY
RATED SAFETY CABLE WHENEVER
INSTALLING THIS FIXTURE IN A
SUSPENDED ENVIRONMENT TO
ENSURE THE FIXTURE WILL NOT FALL
IF THE CLAMP FAILS.

INSTALLATION GUIDELINES

FIXTURE INSTALLATION

The **ELIMINATOR LP 12 HEX PLUS** is fully operational in three different mounting positions: hanging upside-down, mounted sideways on trussing, or set on a flat level surface. Always use and install the supplied safety cable as a safety measure to prevent accidental damage and/or injury in the event the clamp fails.

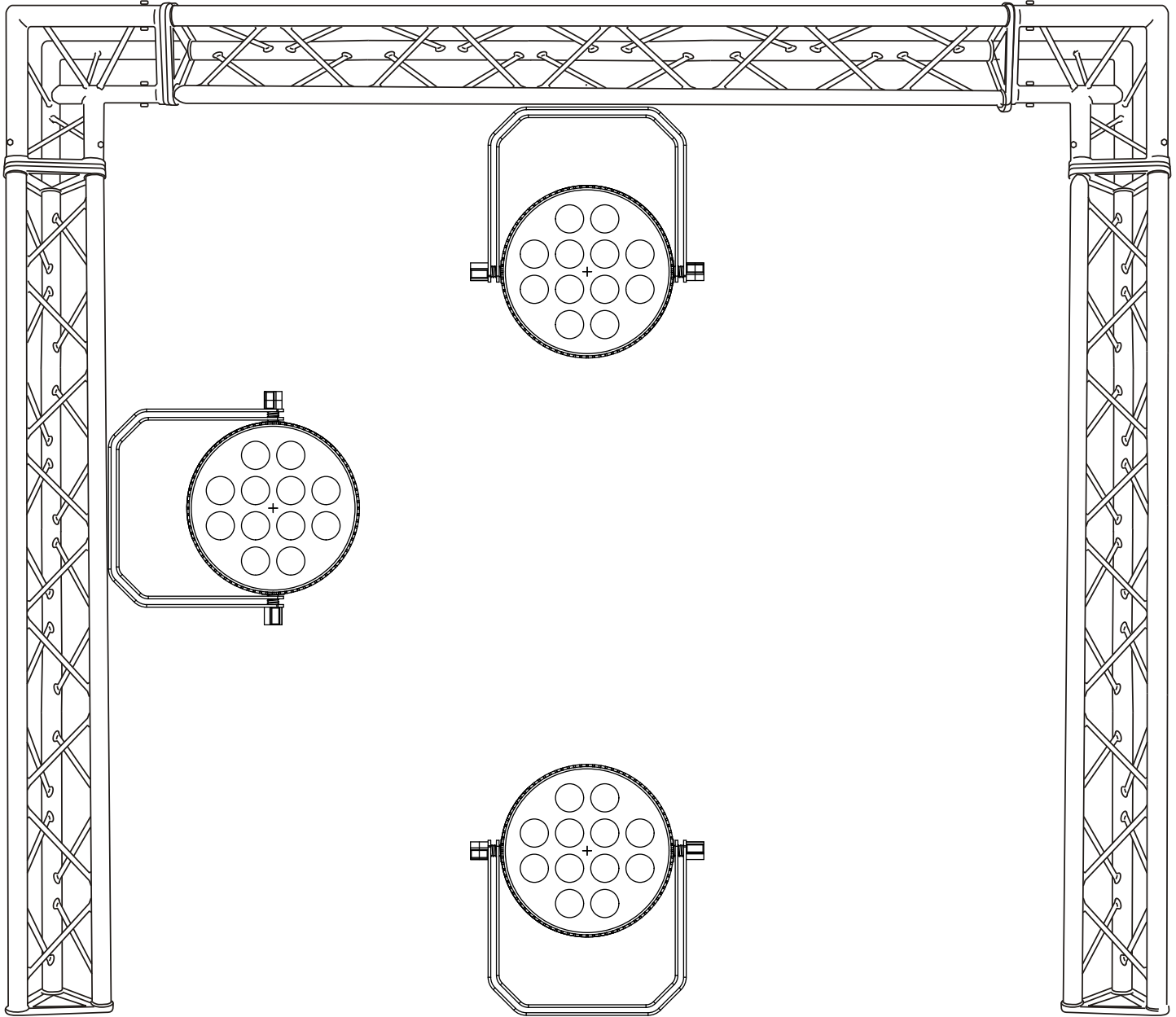

FALLING FIXTURES CAN CAUSE SEVERE INJURY OR SERIOUS EQUIPMENT DAMAGE! FOR THIS REASON, FIXTURES SHOULD BE INSTALLED AND INSPECTED ONLY BY QUALIFIED PERSONNEL. DO NOT INSTALL THE UNIT IF YOU LACK THE QUALIFICATIONS TO DO SO, OR IF YOU HAVE DOUBTS ABOUT THE SAFETY AND SECURITY OF THE INSTALLATION SETUP OR LOCATION!



ALWAYS ATTACH A SAFETY CABLE WHENEVER INSTALLING THIS FIXTURE IN A SUSPENDED ENVIRONMENT TO ENSURE THE FIXTURE WILL NOT FALL IF THE CLAMP FAILS.

INSTALLATION

POTENTIAL INTERNAL FIXTURE DAMAGE FROM EXTERNAL SOURCES OF LIGHT BEAMS

External sources of light beams from direct sunlight, lighting and moving head fixtures, and lasers, which are focused directly towards the exterior housing and/or penetrate the front lens opening of Eliminator lighting fixtures, can cause severe internal damage including burning of optics, dichroic color filters, glass and metal gobos, prisms, animation wheels, frost filters, iris, shutters, motors, belts, wiring, discharge lamps, and LEDs.

This issue is not specific only to Eliminator lighting fixtures, but rather it is a common issue with lighting fixtures from all manufacturers. Although there is no true way to fully prevent this issue from happening, the guidelines below can reduce the risk of potential damage. Contact Eliminator Service for more details.

DO NOT EXPOSE THE FIXTURE AND/OR FRONT LENS OPENING TO LIGHT BEAMS FROM DIRECT SUNLIGHT, OTHER LIGHTING OR MOVING HEAD FIXTURES, AND LASERS DURING UNPACKING, INSTALLATION, USE, AND EXTENDED IDLE TIMES OUTDOORS. DO NOT FOCUS A LIGHT BEAM FROM ONE LIGHTING FIXTURE DIRECTLY TOWARDS ANOTHER.

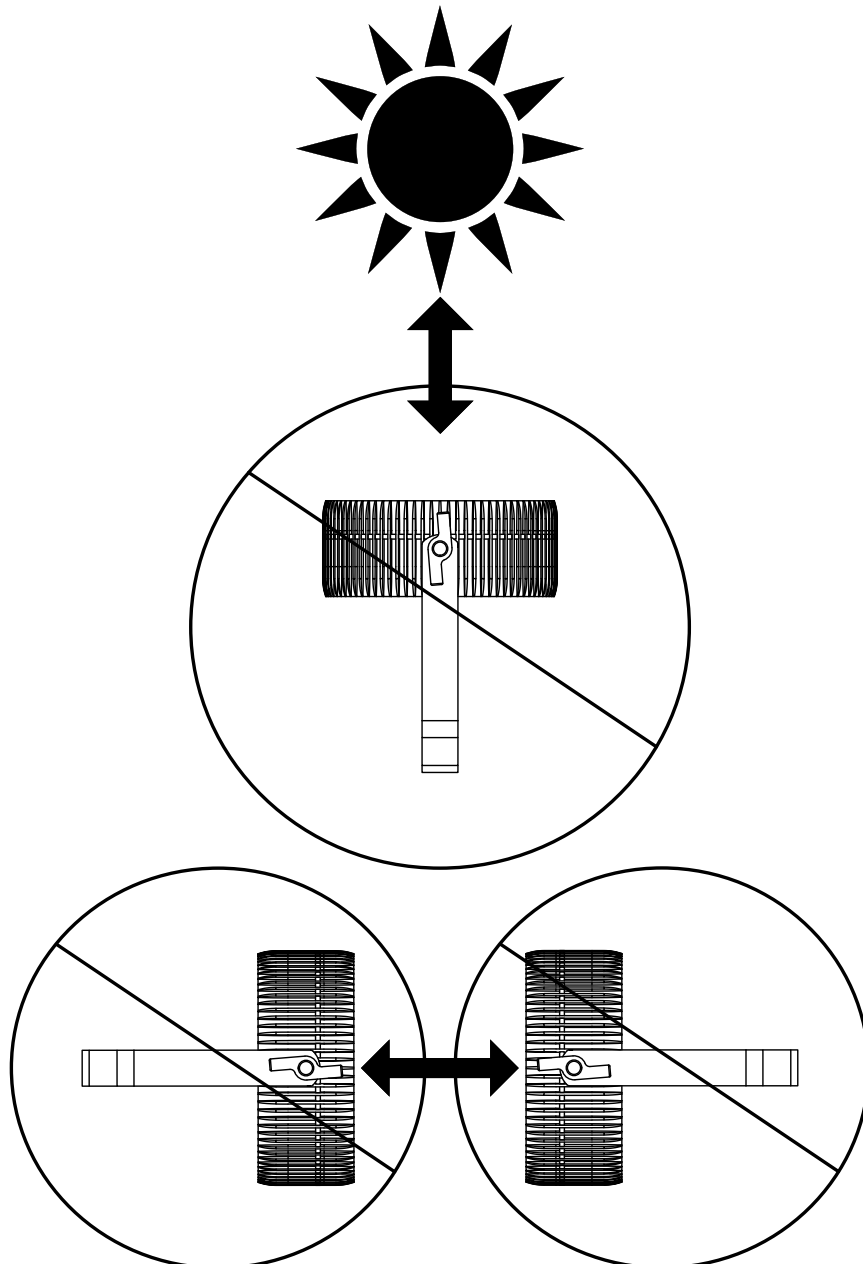

SYSTEM MENU

The fixture includes an easy to navigate system menu control panel display where all necessary settings and adjustments are made.

- **MENU:** Cycles through the main menu options and/or return to previous menu without making changes.
- **DOWN/UP:** Scroll through options in the selected menu.
- **ENTER:** Select highlighted option and/or confirm selection.

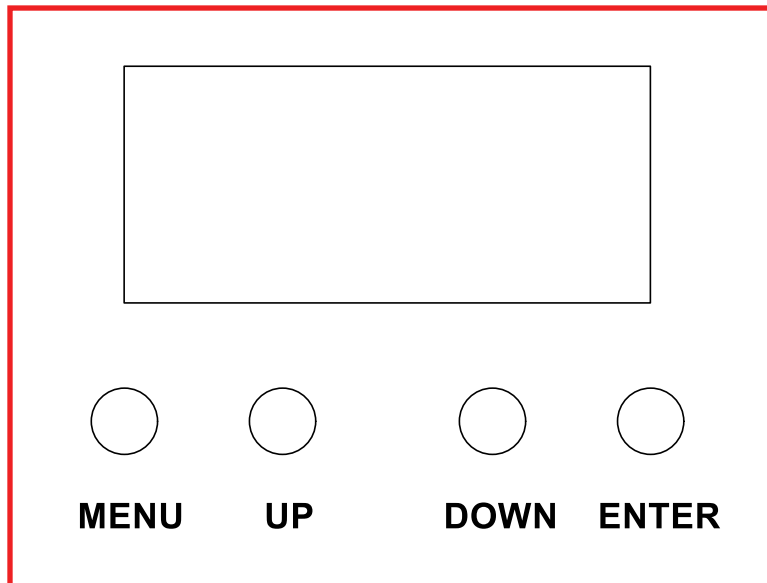

SOFTWARE UPDATES:

Software updates should be performed by trained personnel only! Contact Customer Service at the number or email listed below for assistance with performing software updates.

Tel: (323) 582-2650

support@eliminatorlighting.com

SYSTEM MENU

MENU	OPTIONS / VALUES		DESCRIPTION
A001	DMX address	001~512	10CH mode UP,DOWN increase or reduce the value
d001	DMX address	001~512	6CH mode,UP,DOWN increase or reduce the value
r255	Red dim	000~255	UP,DOWN Change brightness
G255	Green dim	000~255	UP,DOWN Change brightness
b255	Blue dim	000~255	UP,DOWN Change brightness
u255	White dim	000~255	UP,DOWN Change brightness
y255	Amber dim	000~255	UP,DOWN Change brightness
P255	Ultraviolet dim	000~255	UP,DOWN Change brightness
FH99	Strobe/Shutter	01 ~ 99	UP,DOWN change the speed
CL01	Colors choose	01 ~ 08	UP,DOWN Change color
CC99	Colors Jump	01 ~ 99	UP,DOWN change the speed
DE99	Colors Gra-date	01 ~ 99	UP,DOWN change the speed
CP99	Colors Pulse	01 ~ 99	UP,DOWN change the speed
SU01	Colors sound-Active	01~09	UP, DOWN Change the effects

SYSTEM MENU

DMX Mode:

This function will allow you to control each individual fixture's traits with a standard DMX 512 controller. Operating through a DMX controller gives the user the freedom to create their own programs tailored to their own individual needs. The **LP 12 HEX PLUS** has multiple DMX channel modes. See the chart below for the DMX traits and values.

1. To run your fixture in DMX mode press the MENU or UP and DOWN buttons until "Addr" is displayed and press ENTER. "AXXX" will now be displayed. "XXX" represents the current displayed address. Use the UP or DOWN buttons to select your desired DMX address.
2. Press ENTER again to select your desired DMX channel mode. Use the UP and DOWN buttons to find your desired DMX channel mode.
3. After you have chosen your desired DMX address and DMX channel mode, press ENTER and plug in the fixture via the XLR connections to any standard DMX controller.

Jump Change Mode:

1. Plug the fixture in and press the MENU or UP and DOWN buttons until "ASC-" is displayed.
2. Press the ENTER button to adjust the Jump speed. Use the UP and DOWN buttons to adjust the speed.
3. The speed can be adjusted between "AS00" (slowest) to "AS12" (fastest).

Pulse Change Mode:

1. Plug the fixture in and press the MENU or UP and DOWN buttons until "ACC-" is displayed.
2. Press the ENTER button to adjust the Pulse speed. Use the UP and DOWN buttons to adjust the speed.
3. The speed can be adjusted between "AC00" (slowest) to "AC12" (fastest).

Fade Mode:

1. Plug the fixture in and press the MENU or UP and DOWN buttons until "FAde" is displayed.
2. Press the ENTER button to adjust the Fade speed. Use the UP and DOWN buttons to adjust the speed.
3. The speed can be adjusted between "FA00" (slowest) to "FA12" (fastest).

Sound Active Pulse Mode:

1. Plug the fixture in and press the MENU or UP and DOWN buttons until "SOUF" is displayed.
2. Press the ENTER button to adjust the sound sensitivity. Use the UP and DOWN buttons to adjust the sensitivity. The sensitivity can be adjusted between "SF00" (least sensitive) to "SF12" (most sensitive).

RGBW + UV Dimmer Mode:

1. Plug the fixture in and press the MENU or UP and DOWN buttons until "rL", "gL", "bL", "uL", "yL" or "PL" is displayed, and press ENTER.
2. Use the UP and DOWN buttons to adjust the output intensity. When you are finished adjusting press ENTER.

Flash / Strobe Mode:

1. After you have adjusted the colors you can activate strobing by pressing the MENU button until "FLAS" is displayed and press ENTER.
2. Use the UP and DOWN buttons to adjust the flash/strobe speed. The speed can be adjusted between "FL00" to "FL12".

DIMMER MODES AND CURVES

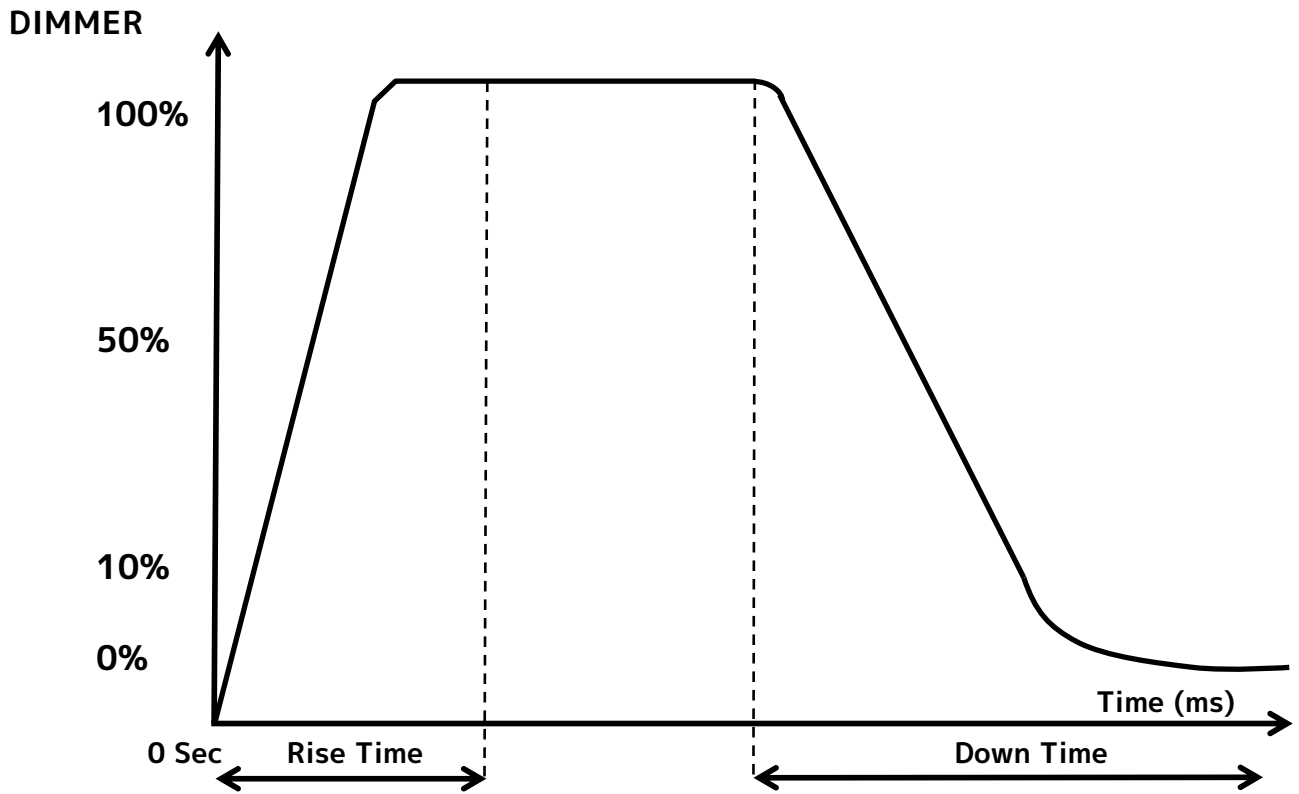

Dimming Curve Ramp Effect	0 sec Fade Time		1 sec Fade Time	
	Rise Time (ms)	Down Time (ms)	Rise Time (ms)	Down Time (ms)
Standard (default)	0	0	0	0
Stage	780	1100	1540	1660
TV	1180	1520	1860	1940
Architectural	1380	1730	2040	2120
Theatre	1580	1940	2230	2280
Stage 2	0	1100	0	1660

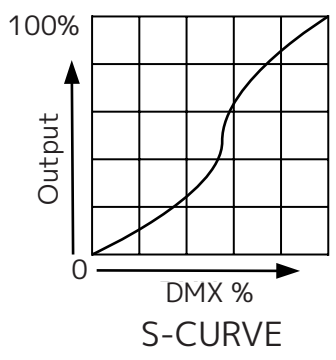
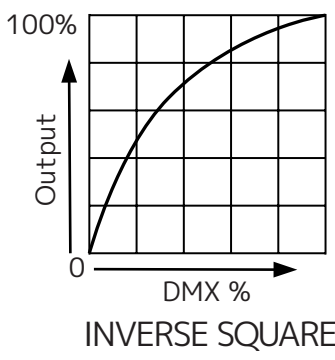
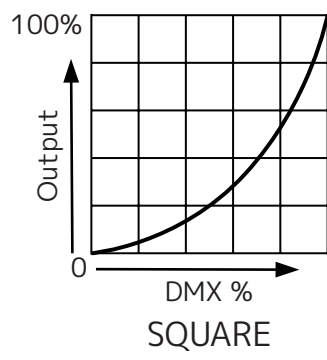
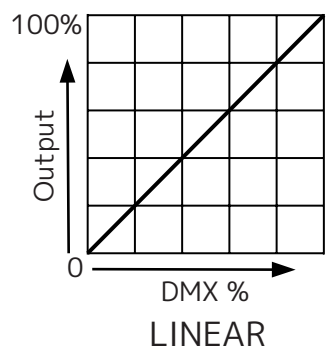

DMX SETUP

DMX-512: DMX is short for Digital Multiplex. This is a universal protocol used as a form of communication between intelligent fixtures and controllers. A DMX controller sends DMX data instructions from the controller to the fixture. DMX data is sent as serial data that travels from fixture to fixture via the DATA “IN” and DATA “OUT” XLR terminals located on all DMX fixtures (most controllers only have a DATA “OUT” terminal).

DMX Linking: DMX is a language allowing all makes and models of different manufacturers to be linked together and operate from a single controller, as long as all fixtures and the controller are DMX compliant. To ensure proper DMX data transmission, try to use the shortest cable path possible when linking several DMX fixtures. The order in which fixtures are connected in a DMX line does not influence the DMX addressing. For example, a fixture assigned a DMX address of 1 may be placed anywhere in a DMX line: at the beginning, at the end, or anywhere in the middle. When a fixture is assigned a DMX address of 1, the DMX controller knows to send DATA assigned to address 1 to that unit, no matter where it is located in the DMX chain.

Data Cable (DMX Cable) Requirements (For DMX Operation): This unit can be controlled via DMX-512 protocol and features 2 selectable DMX modes. Please refer to the **DMX Traits** section of this manual for detailed information. The DMX address can be set using the controls on the rear panel of the unit. Your unit and your DMX controller require a 3-pin XLR connector for data input/output. We recommend Accu-Cable DMX cables. If you are making your own cables, be sure to use standard 110-120 Ohm shielded cable (This cable may be purchased at almost all pro lighting stores). Your cables should be made with a male XLR connector on one end and a female XLR connector on the other. Also remember that DMX cable must be daisy chained and cannot be split.



Special Note: Line Termination. When longer runs of cable are used, you may need to use a terminator on the last unit to avoid erratic behavior. A terminator is a 110-120 ohm 1/4 watt resistor which is connected between pins 2 and 3 of a male XLR connector (DATA + and DATA -). This unit is inserted in the female XLR connector of the last unit in your daisy chain to terminate the line. Using a cable terminator (ADJ part number Z-DMX/T) will decrease the possibilities of erratic behavior.

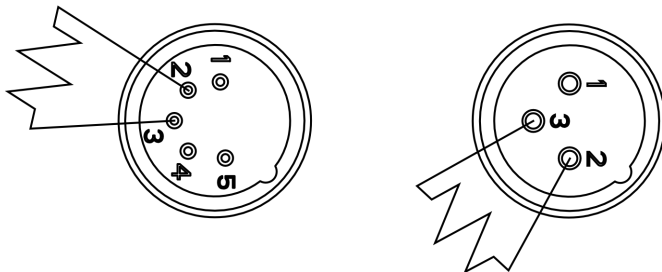

A DMX512 terminator reduces signal errors, avoiding most signal reflection interference. Connect PIN 2 (DMX-) and PIN 3 (DMX+) of the last fixture in series with a 120 Ohm, 1/4 W Resistor to terminate the DMX512.

5-Pin XLR DMX Connectors: Some manufacturers use 5-pin DMX-512 data cables for DATA transmission in place of 3-pin. 5-pin DMX fixtures may be integrated into a 3-pin DMX line with a 5-pin to 3-pin adapter cable. These adapters are readily available at most electronics stores. Follow the chart below for a proper conversion.

3-Pin XLR to 5-Pin XLR Conversion		
Ground/Shield	Pin 1	Pin 1
Data Compliment (- signal)	Pin 2	Pin 2
Data True (+ signal)	Pin 3	Pin 3
Not Used		Do Not Use
Not Used		Do Not Use

DMX SETUP

DMX Addressing:

All fixtures should be given a DMX starting address when using a DMX controller, in order to ensure that the correct fixture responds to the correct control signal. This digital starting address is the channel number from which the fixture starts to “listen” to the digital control signal sent out from the DMX controller. The assignment of this starting DMX address is achieved by setting the correct DMX address on the digital control display on the fixture.

You can set the same starting address for all fixtures or a group of fixtures, or set different addresses for each individual fixture. Setting all fixtures to the same DMX address will cause all fixtures to react in the same way; in other words, changing the settings of one channel will affect all the fixtures simultaneously.

If you set each fixture to a different DMX address, each unit will start to “listen” to the channel number you have set, based on the quantity of DMX channels of each fixture. That means changing the settings of one channel will only affect the selected fixture. For instance, when this unit is set to 10 Channel mode, you should set the starting DMX address of the first unit to 1, the second unit to 11 (1 + 10), the third unit to 21 (1 + 10 + 10), the fourth unit to 31 (1 + 10 + 10 + 10), etc...

Channel Mode	Unit 1 Address	Unit 2 Address	Unit 3 Address	Unit 4 Address
6Ch	1	7	13	19
10Ch	1	11	21	31

DMX TRAITS

CHANNEL		DMX VALUES	FUNCTION
6Ch	10Ch		
	1	000-255	Total Dimmer , RGBWA+UV Total Dimmer- Dark to Bright
1	2	000-255	R Dimmer , Red Dimmer- Dark to Bright
2	3	000-255	G Dimmer , Green Dimmer- Dark to Bright
3	4	000-255	B Dimmer , Blue Dimmer- Dark to Bright
4	5	000-255	W Dimmer , White Dimmer- Dark to Bright
5	6	000-255	A Dimmer , Amber Dimmer- Dark to Bright
6	7	000-255	UV Dimmer , Ultraviolet Dimmer- Dark to Bright
	8		Strobe/Shutter
		000-031	Shutter Closed (LEDs OFF)
		032-063	Shutter OPEN (LEDS ON)
		064-095	Strobe effect slow to fast
		096-127	Shutter OPEN(LEDS ON)
		128-159	Pulse effect in sequences
		160-191	Shutter OPEN(LEDS ON)
		192-223	Random strobe effect slow to fast
	224-255	Shutter OPEN(LEDS ON)	
	9		Function Choice
		000~050	CH1-CH8 Control.
		051~100	Different Colors output
		101~150	Colors Jump Change.
		151~200	Colors Gradate.
		201~250	Colors Pulse Change.
	251~255	Sound-Active	
	10	000-255	Function/Speed , Slow to Fast (At the Colors output and sound choose the color)

MULTI-UNIT POWER-LINKING

This feature allows multiple units to be linked together via their power in/out ports. The maximum number of units that can be linked in this manner is as follows:

- **8 units maximum at 120V.**

DO NOT EXCEED THIS MAXIMUM NUMBER WHEN LINKING UNITS!

DO NOT MIS MAKE AND MODEL TYPES WHEN LINKING UNITS! All units that are connected in this manner must be of the same make and model type!

MAINTENANCE



DISCONNECT POWER BEFORE PERFORMING ANY MAINTENANCE!

CLEANING

Frequent cleaning is recommended to ensure proper function, optimized light output, and an extended life. The frequency of cleaning depends on the environment which the device operates in: damp, smoky or particularly dirty environments can cause greater accumulation of dirt on the fixture housing and/or light fixture optics. Clean the external surface and the front lens of the light at least every 20 days with a soft cloth to avoid dirt/debris accumulation

NEVER use alcohol, solvents, or ammonia-based cleaners.

MAINTENANCE

Regular inspections are recommended to ensure proper function and extended life. There are no user serviceable parts inside these devices, please refer all other service issues to Eliminator Lighting. Should you need any spare parts, please order genuine parts from Eliminator Lighting.

Please refer to the following points during routine inspections:

- A detailed review by an approved electrical engineer every three months, to make sure the circuit contacts are in good condition and prevent overheating.
- Be sure all screws and fasteners are securely tightened at all times. Loose screws may fall out during normal operation resulting in damage or injury as larger parts could fall.
- Check for any deformations on the light housing, lens, rigging hardware and rigging points (ceiling, suspension, trussing, etc.). Deformations could allow for dust to enter into the devices. Damaged rigging points or unsecured rigging could cause the devices to fall and seriously injure a person(s).
- Electric power supply cables must not show any damage, material fatigue or sediments.

TROUBLESHOOTING

The light does not turn ON.

1. Confirm the AC power cord from the light is not damaged or cut.
2. Check if circuit breaker that controls the AC outlet that the light is plugged into is not tripped.
3. Confirm the power connection is not loose.
4. If none of these solutions work, please contact Eliminator Lighting Customer Service.

The unit is not responding to DMX.

1. Check that the DMX cables are connected properly and are wired correctly.
2. Check that all cables are connected to the right connectors

SPECIFICATIONS

LED: 12 × 18W RGBWA+UV 6-in-1 LED's

25° Beam Angle

Light Effect: Pure color, excellent color mixing, smooth wash output

DMX Channel Modes: 6 / 10

Functions: White light balance setting, color cast correction

Temperature Control Protection

Control Modes: DMX512, Primary-Secondary, Auto Run, Sound Active

Dimmer: 0–100% linear dimming

Strobe: High-speed synchronous strobe

Input Power: AC100–240V, 50/60Hz

Power Consumption: 110W

Metal Housing

Product Dimensions: 8.27" × 9.84" × 7.48" (210 × 250 × 190 mm)

Net Weight: 5.51 lb (2.5 k)

IP Rating: IP20



DIMENSIONAL DRAWINGS

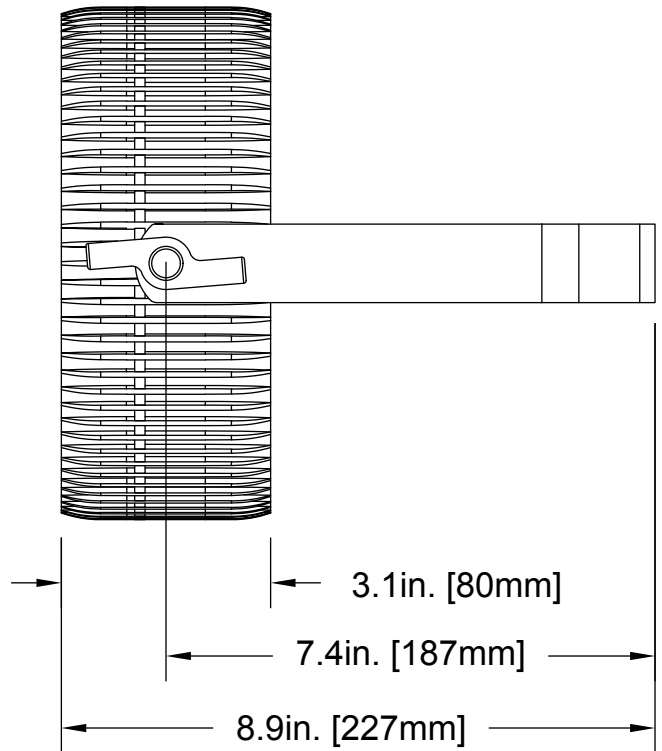
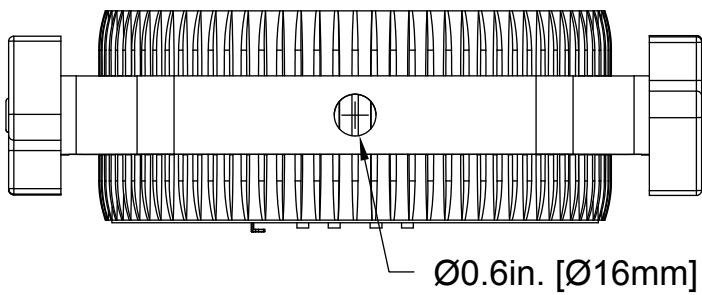
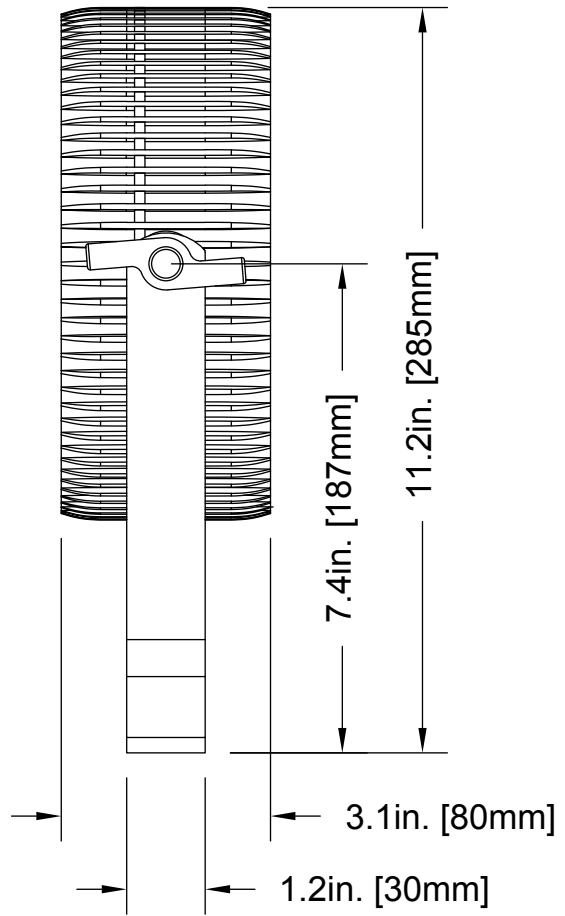
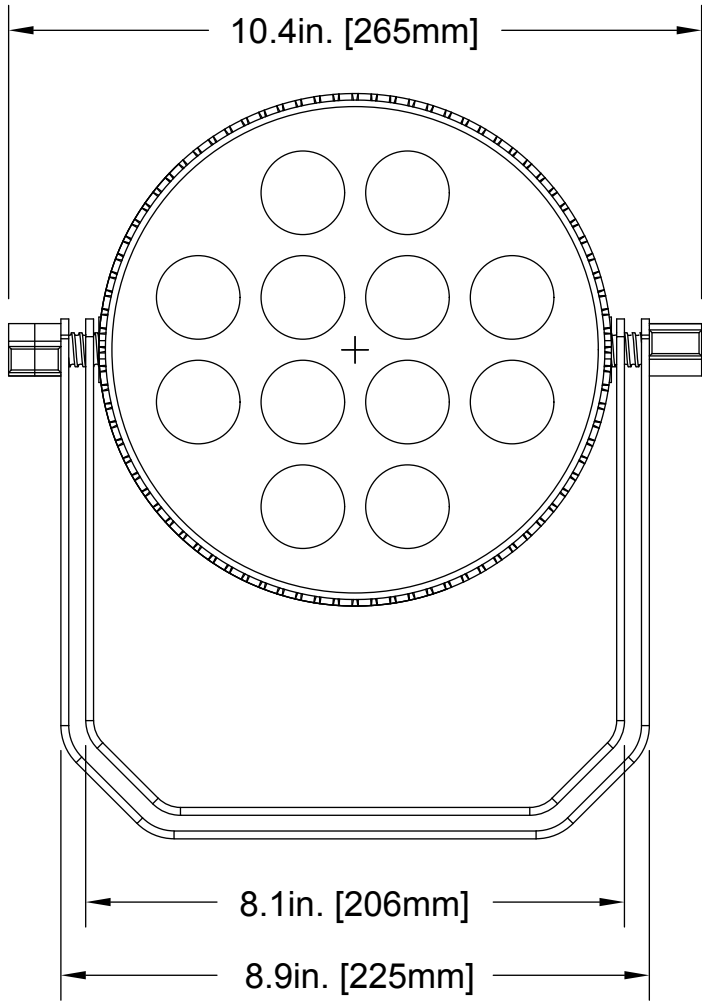

OPTIONAL ACCESSORIES

ORDER CODE		ITEM
US	EU	
HEX100	1900000054	LP HEX 12 PLUS
TRIGGER CLAMP	N/A	Heavy Duty Wrap Around Hook Style Clamp
TOU027	N/A	5 ft. (1.5m) 5pin PRO DMX Cable
		Additional Cable Lengths Available



FCC STATEMENT

This device complies with Part 15 of the FCC Rules. Operation is subject to the following two conditions: (1) this device may not cause harmful interference, and (2) this device must accept any interference received, including interference that may cause undesired operation.

Please note that changes or modifications of this product is not expressly approved by the party responsible for compliance could void the user's authority to operate the equipment. NOTE: This equipment has been tested and found to comply with the limits for a Class A digital device, pursuant to part 15 of the FCC Rules. These limits are designed to provide reasonable protection against harmful interference when the equipment is operated in a commercial environment. This equipment generates, uses, and can radiate radio frequency energy and, if not installed and used in accordance with the instruction manual, may cause harmful interference to radio communications. Operation of this equipment in a residential area is likely to cause harmful interference in which case the user will be required to correct the interference at his own expense.

Europe Energy Saving Notice

Energy Saving Matters (EuP 2009/125/EC)

Saving electric energy is a key to help protecting the environment. Please turn off all electrical products when they are not in use. To avoid power consumption in idle mode, disconnect all electrical equipment from power when not in use. Thank you

