

ELATION[®]



KL Profile Compact

Photometric &
Chromaticity Test Reports

CONTENTS

Testing Procedures	4
Photometric Output Reports	5
26° Lens	5
Full Output	5
2400K	7
3200K	9
5600K	11
6500K	13
8500K	15
36° Lens	17
Full Output	17
2400K	19
3200K	21
5600K	23
6500K	25
8500K	27
50° Lens	29
Full Output	29
2400K	31
3200K	33
5600K	35
6500K	37
8500K	39
Color Quality Reports	41
Full Output	41
2700K	43
3200K	45
5600K	47
6500K	49
8500K	51



LED Color Information Reports 53

Red 53

Green 54

Blue 55

Mint 56

Amber 57

©2026 ELATION PROFESSIONAL all rights reserved. Information, specifications, diagrams, images, and instructions herein are subject to change without notice. ELATION PROFESSIONAL logo and identifying product names and numbers herein are trademarks of ELATION PROFESSIONAL. Copyright protection claimed includes all forms and matters of copyrightable materials and information now allowed by statutory or judicial law or hereinafter granted. Product names used in this document may be trademarks or registered trademarks of their respective companies and are hereby acknowledged. All non-ELATION brands and product names are trademarks or registered trademarks of their respective companies.

Elation Professional USA | 6122 S. Eastern Ave. | Los Angeles, CA. 90040
323-582-3322 | 323-832-9142 fax | www.elationlighting.com | info@elationlighting.com

Elation Professional B.V. | Junostraat 2 | 6468 EW Kerkrade, The Netherlands
+31 45 546 85 66 | +31 45 546 85 96 fax | www.elationlighting.eu | info@elationlighting.eu

Elation Professional Mexico | AV Santa Ana 30 | Parque Industrial Lerma, Lerma, Mexico 52000

+52 (728) 282-7070

Testing Process

Total Lumen Measurements

Lumens are measured using a Viso Systems Lab Spion. As a goniophotometer, the Viso calculates the field lumens of the fixture by taking multiple measurements across the light beam.

Many lumens figures provided for entertainment lighting fixtures are only 2π sphere values, some even emphasize the LED engine lumens. All Elation product photometric data is the actual light output from the fixture lens, never a theoretical value based on calculation or using the source lumens as the fixtures output. We advise to always compare total fixture lumens acquired with identical measurement systems when comparing lighting fixtures.

Test Lab Equipment and Process

Elation operates an optical testing laboratory at its Los Angeles, CA headquarters to provide accurate photometric data for its lighting products. The testing lab is both light and climate- controlled and contains a variety of precise lighting measurement systems. Fixtures are analyzed with the sophisticated [Viso Systems Lab Spion](#) equipment, which measures all light and color parameters by panning the light beam at a precise speed and from different angles through a calibrated, laser aligned light and color sensor. Test data is collected and summarized by the Viso Light Inspector software. This type of measurement system is referred to as a Goniophotometer.

The Viso software calculates all relevant types of measurements, from beam angles, candela to center light intensity at a variety of distances to the latest color quality measurements like TM30 or CQS as well as accurate color temperature. This wealth of data is then processed by an Elation specific template which is included in the photometric test report for various fixture conditions such as zoom angles and color correction filters.

The Viso software also creates IES (Illuminating Engineering Society) files for each test report. IES is an industry standard file format created for the easy electronic transfer of photometric test data, which is widely used by lighting manufacturers for photometric data distribution.

Additionally, fixtures are periodically rechecked for accuracy using various hand-held light meters including one or more of the devices listed below. This is done to ensure the test data contained in this report is as accurate as possible.

[Asenstek Lighting Passport](#) | [Konica Minolta T-10](#) | [Sekonic C800U](#)

Key Measurements

Output

Total Lumen Output: 4916 lm

Peak Intensity: 48117 cd

Beam

Beam Angle (50%): 22.5°

Field Angle (10%): 25.3°

Cutoff Angle (2.5%): 26.3°

Color

Color Temperature: 6066 K

CRI: 91.2

TLCI: 94

TM30 R_F: 89.3

TM30 R_g: 105.7

Power Details

Efficacy: 21 Lumen/Watt

Power: 239 W

Supply Voltage: 117 V

Current: 2.04 A

Beam Details

Distance	3 m	5 m	10 m	15 m	20 m
Beam Width	1.2 m	2 m	4 m	6 m	8 m

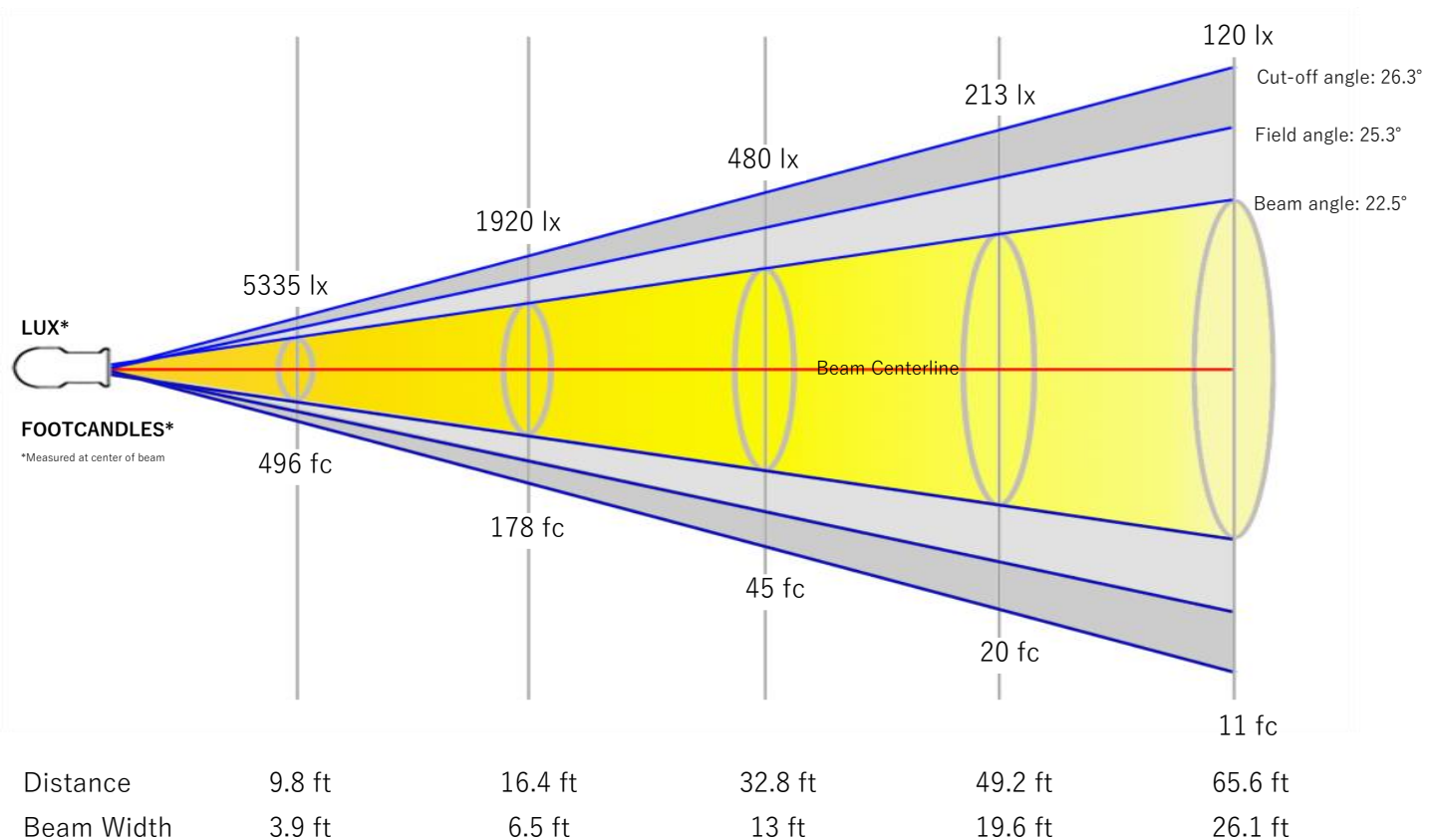

Beam Intensities from 1-20m

M	1	2	3	4	5	6	7	8	9	10	11	12	13	14	15	16	17	18	19	20
LX	48011	12003	5335	3001	1920	1334	980	750	593	480	397	333	284	245	213	188	166	148	133	120
FT	3.3	6.6	9.8	13.1	16.4	19.7	23	26.2	29.5	32.8	36.1	39.4	42.7	45.9	49.2	52.5	55.8	59.1	62.3	65.6
FC	4460.4	1115.1	495.6	278.8	178.4	123.9	91	69.7	55.1	44.6	36.9	31	26.4	22.8	19.8	17.4	15.4	13.8	12.4	11.2

Angular Distribution

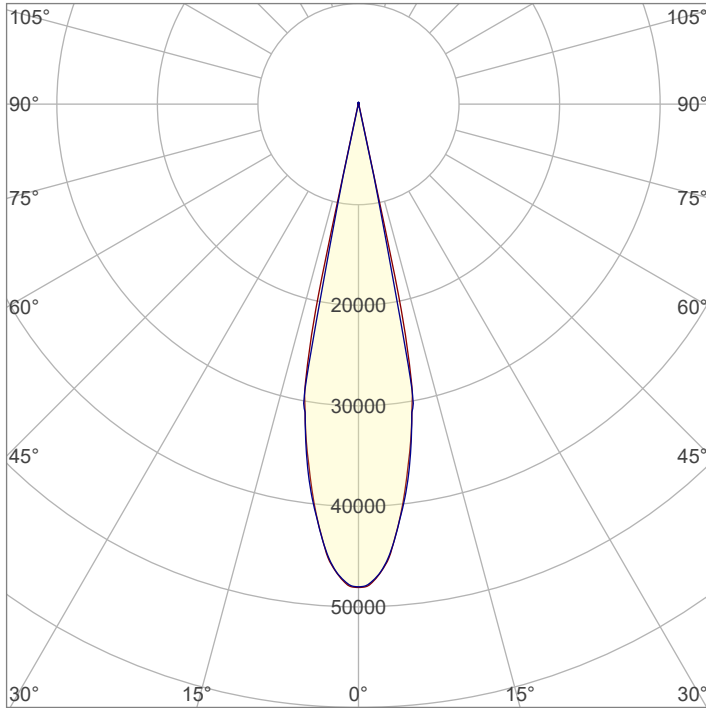

Beam Angle - 50%
22.5°
Field Angle - 10%
25.3°
Cutoff Angle - 2.5%
26.3°

ISO Diagrams

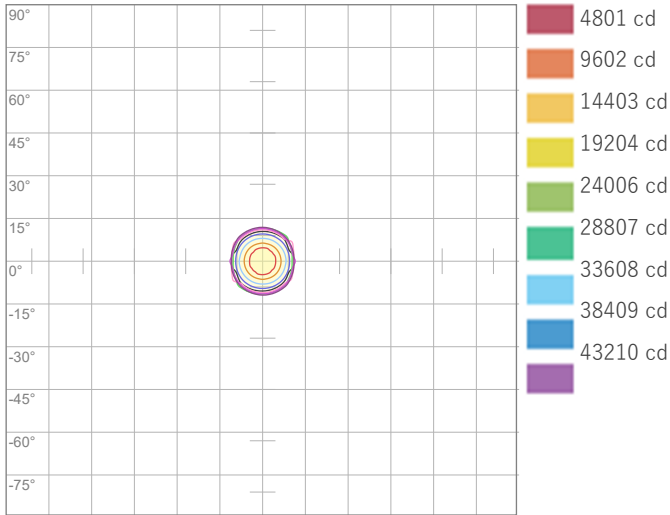

ISO Candela Diagram

Conditions:

Number of c-planes: 8

Candela at center: 48011 cd

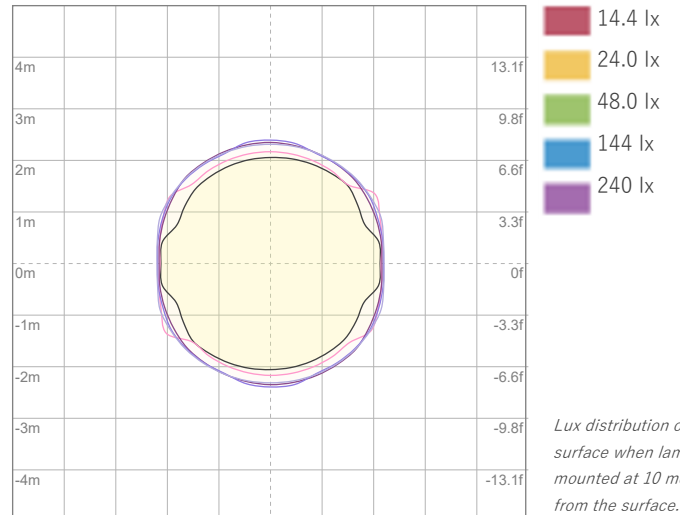

ISO LUX Diagram

Conditions:

Number of c-planes: 8

LUX at center: 480 lx

Lux distribution on a surface when lamp is mounted at 10 meters from the surface.

Linear Distribution

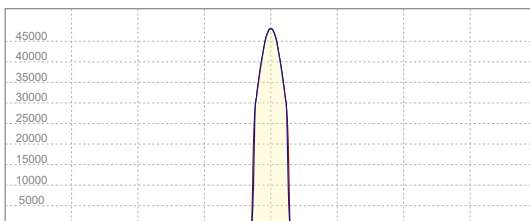

Peak Candela
48117 cd

Calculate Center Beam Intensities

$$\text{lux} = 48117 / \text{distance(m)}^2$$

$$\text{fc} = 48117 / \text{distance(ft)}^2$$

Key Measurements

Output

Total Lumen Output: 4827 lm

Peak Intensity: 47146 cd

Beam

Beam Angle (50%): 22.6°

Field Angle (10%): 25.3°

Cutoff Angle (2.5%): 26.7°

Color

Color Temperature: 2714 K

CRI: 89.1

TLCI: 93

TM30 R_F: 92.4

TM30 R_g: 107.0

Power Details

Efficacy: 20 Lumen/Watt

Power: 244 W

Supply Voltage: 117 V

Current: 2.09 A

Beam Details

Distance	3 m	5 m	10 m	15 m	20 m
Beam Width	1.2 m	2 m	4 m	6 m	8 m

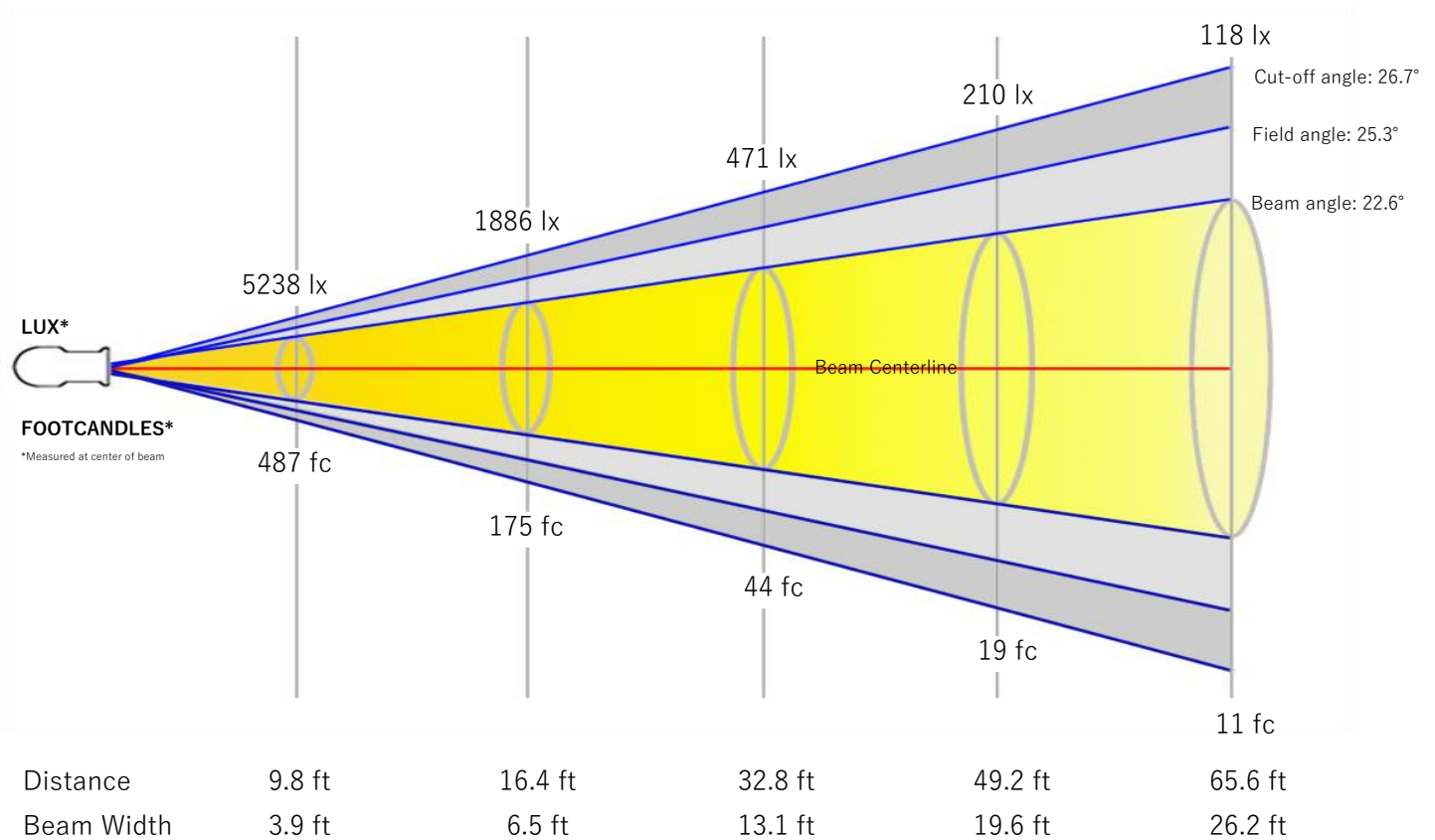

Beam Intensities from 1-20m

M	1	2	3	4	5	6	7	8	9	10	11	12	13	14	15	16	17	18	19	20
LX	47146	11787	5238	2947	1886	1310	962	737	582	471	390	327	279	241	210	184	163	146	131	118
FT	3.3	6.6	9.8	13.1	16.4	19.7	23	26.2	29.5	32.8	36.1	39.4	42.7	45.9	49.2	52.5	55.8	59.1	62.3	65.6
FC	4380	1095	486.7	273.8	175.2	121.7	89.4	68.4	54.1	43.8	36.2	30.4	25.9	22.3	19.5	17.1	15.2	13.5	12.1	11

Angular Distribution

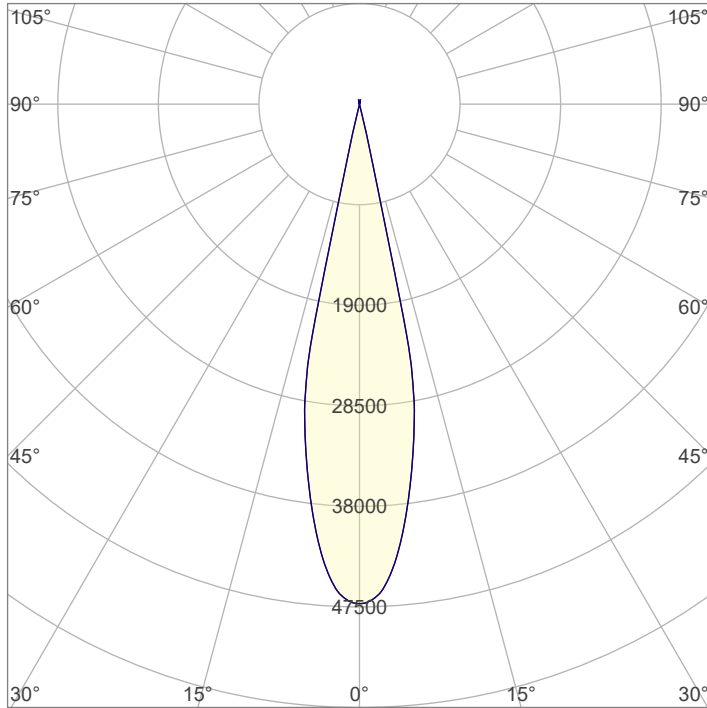

Beam Angle - 50%
22.6°
Field Angle - 10%
25.3°
Cutoff Angle - 2.5%
26.7°

ISO Diagrams

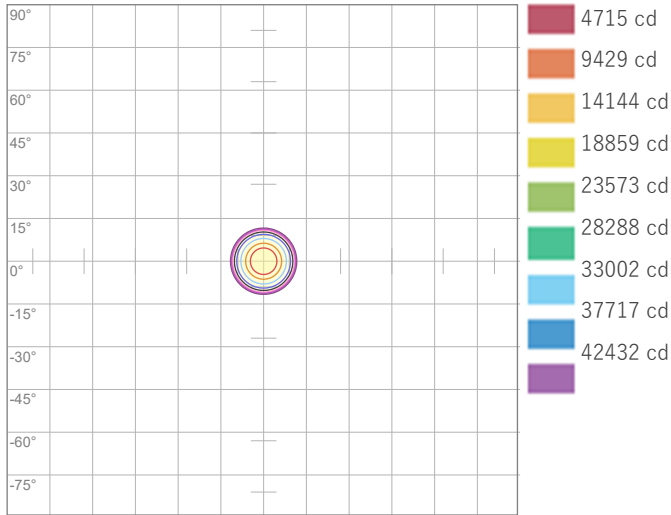

ISO Candela Diagram

Conditions:

Number of c-planes: 8

Candela at center: 47146 cd

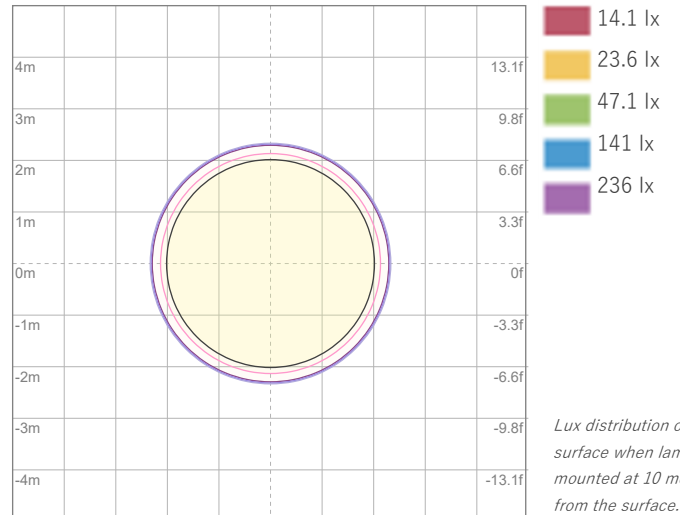

ISO LUX Diagram

Lux distribution on a surface when lamp is mounted at 10 meters from the surface.

Conditions:

Number of c-planes: 8

LUX at center: 471 lx

Linear Distribution

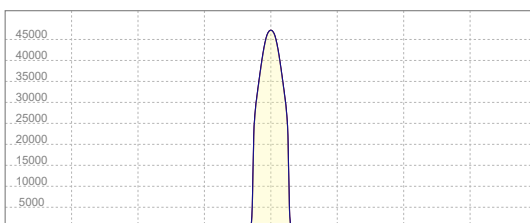

Peak Candela
47146 cd

Calculate Center Beam Intensities

$$\text{lux} = 47146 / \text{distance(m)}^2$$

$$\text{fc} = 47146 / \text{distance(ft)}^2$$

Key Measurements

Output

Total Lumen Output: 5162 lm

Peak Intensity: 50826 cd

Beam

Beam Angle (50%): 22.6°

Field Angle (10%): 25.3°

Cutoff Angle (2.5%): 26.4°

Color

Color Temperature: 3251 K

CRI: 90.7

TLCI: 94

TM30 R_F: 92.0

TM30 R_g: 106.1

Power Details

Efficacy: 21 Lumen/Watt

Power: 245 W

Supply Voltage: 116 V

Current: 2.11 A

Beam Details

Distance	3 m	5 m	10 m	15 m	20 m
Beam Width	1.2 m	2 m	4 m	6 m	8 m

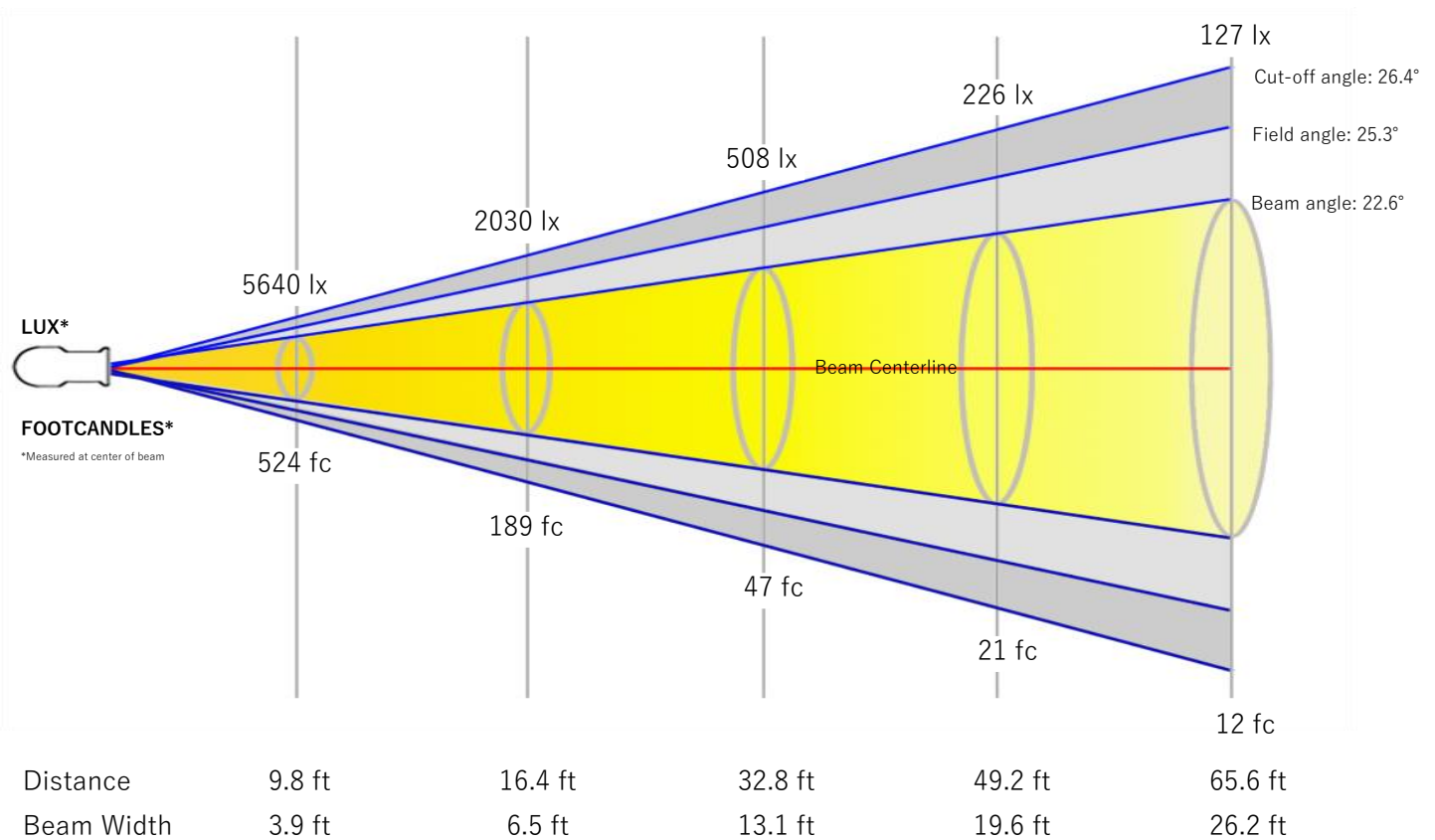

Beam Intensities from 1-20m

M	1	2	3	4	5	6	7	8	9	10	11	12	13	14	15	16	17	18	19	20
LX	50762	12691	5640	3173	2030	1410	1036	793	627	508	420	353	300	259	226	198	176	157	141	127
FT	3.3	6.6	9.8	13.1	16.4	19.7	23	26.2	29.5	32.8	36.1	39.4	42.7	45.9	49.2	52.5	55.8	59.1	62.3	65.6
FC	4716	1179	524	294.7	188.6	131	96.2	73.7	58.2	47.2	39	32.7	27.9	24.1	21	18.4	16.3	14.6	13.1	11.8

Angular Distribution

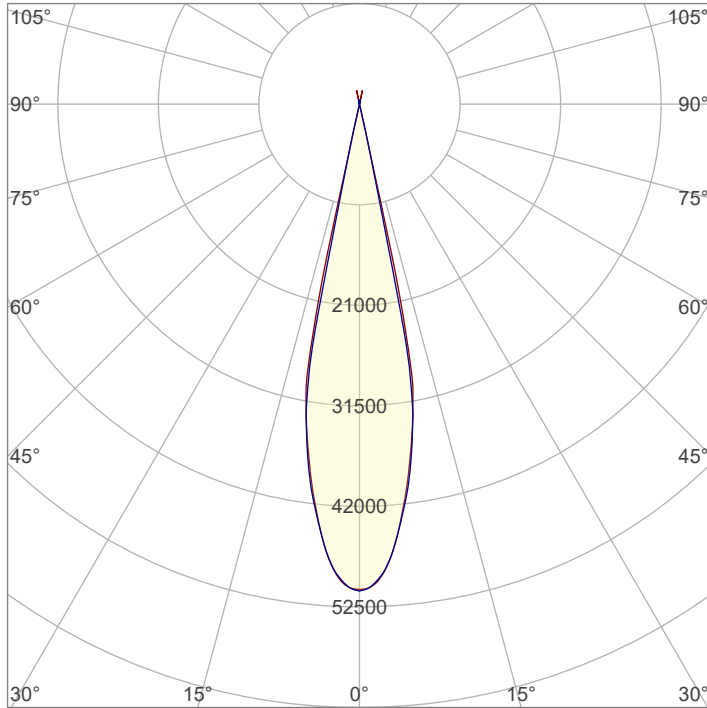

Beam Angle - 50%
22.6°
Field Angle - 10%
25.3°
Cutoff Angle - 2.5%
26.4°

ISO Diagrams

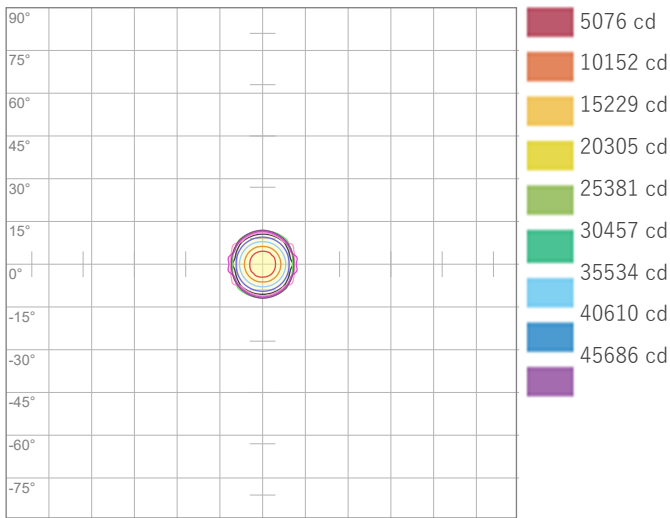

ISO Candela Diagram

Conditions:

Number of c-planes: 8

Candela at center: 50762 cd

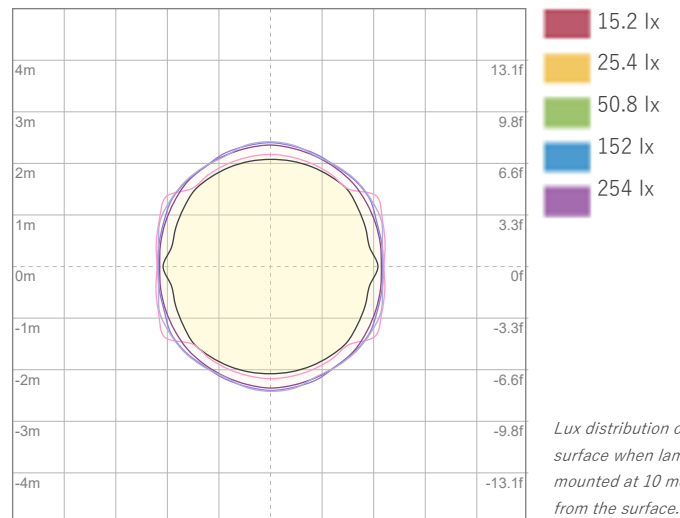

ISO LUX Diagram

Conditions:

Number of c-planes: 8

LUX at center: 508 lx

Lux distribution on a surface when lamp is mounted at 10 meters from the surface.

Linear Distribution

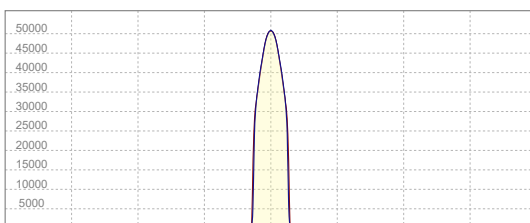

Peak Candela
50826 cd

Calculate Center Beam Intensities

$$\text{lux} = 50826 / \text{distance(m)}^2$$

$$\text{fc} = 50826 / \text{distance(ft)}^2$$

Key Measurements

Output

Total Lumen Output: 4995 lm

Peak Intensity: 48402 cd

Beam

Beam Angle (50%): 22.7°

Field Angle (10%): 25.5°

Cutoff Angle (2.5%): 26.7°

Color

Color Temperature: 5657 K

CRI: 90.1

TLCI: 93

TM30 R_F: 89.5

TM30 R_g: 106.5

Power Details

Efficacy: 21 Lumen/Watt

Power: 240 W

Supply Voltage: 116 V

Current: 2.07 A

Beam Details

Distance	3 m	5 m	10 m	15 m	20 m
Beam Width	1.2 m	2 m	4 m	6 m	8 m

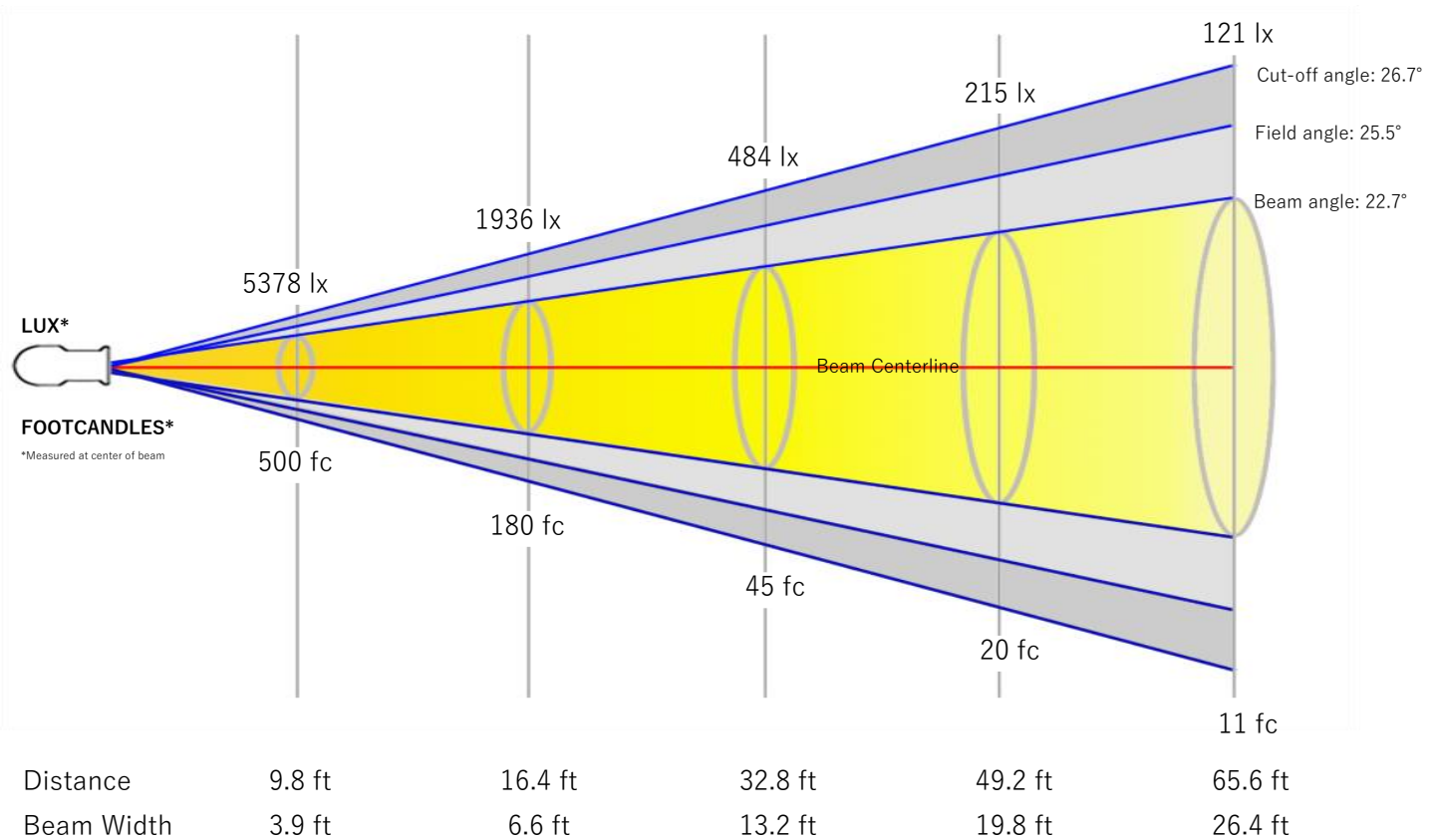

Beam Intensities from 1-20m

M	1	2	3	4	5	6	7	8	9	10	11	12	13	14	15	16	17	18	19	20
LX	48402	12101	5378	3025	1936	1345	988	756	598	484	400	336	286	247	215	189	167	149	134	121
FT	3.3	6.6	9.8	13.1	16.4	19.7	23	26.2	29.5	32.8	36.1	39.4	42.7	45.9	49.2	52.5	55.8	59.1	62.3	65.6
FC	4496.7	1124.2	499.6	281	179.9	124.9	91.8	70.3	55.5	45	37.2	31.2	26.6	22.9	20	17.6	15.6	13.9	12.5	11.2

Angular Distribution

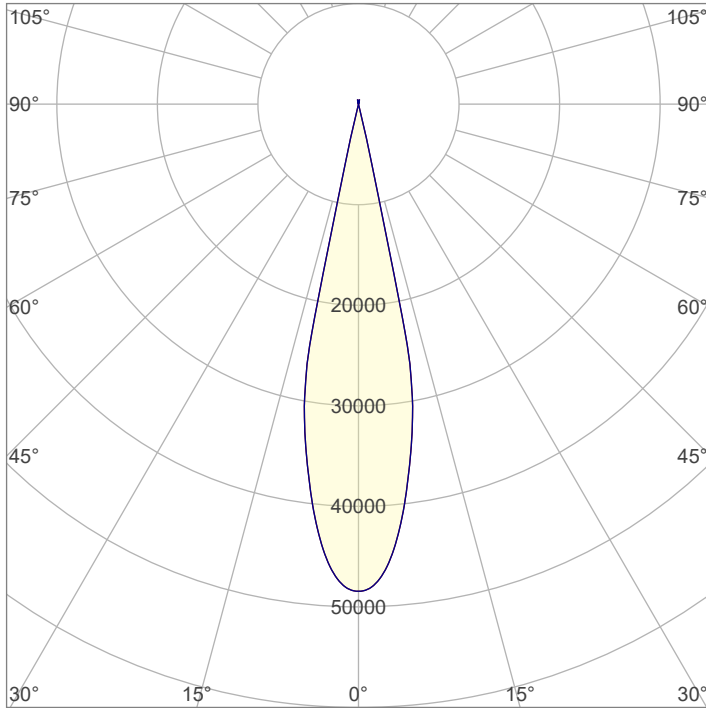

Beam Angle - 50%
22.7°
Field Angle - 10%
25.5°
Cutoff Angle - 2.5%
26.7°

ISO Diagrams

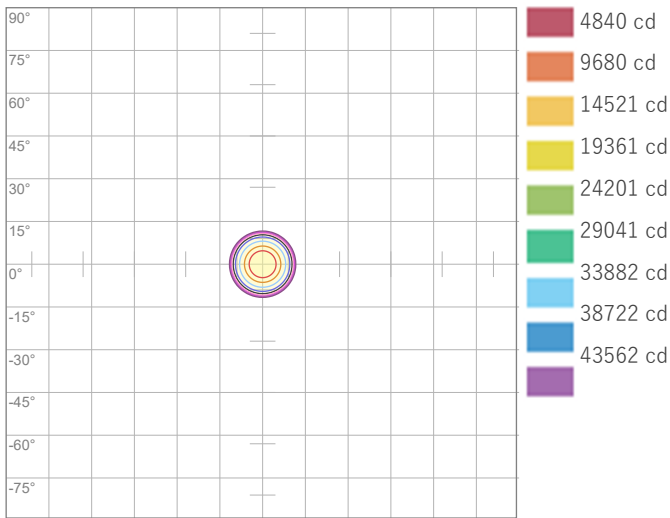

ISO Candela Diagram

Conditions:

Number of c-planes: 8

Candela at center: 48402 cd

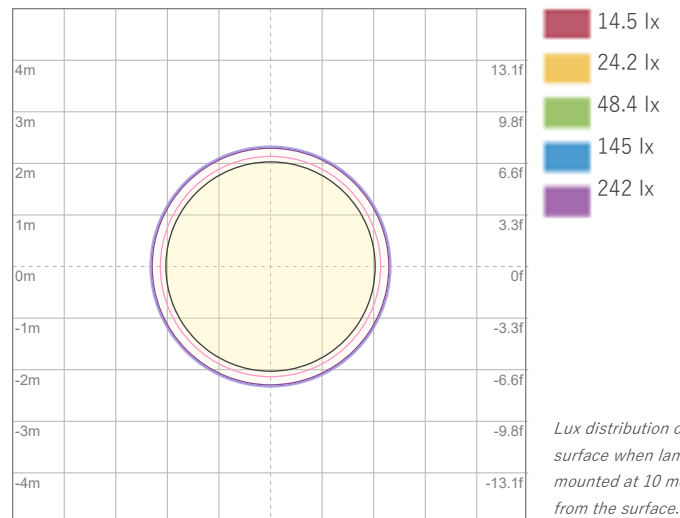

ISO LUX Diagram

Conditions:

Number of c-planes: 8

LUX at center: 484 lx

Lux distribution on a surface when lamp is mounted at 10 meters from the surface.

Linear Distribution

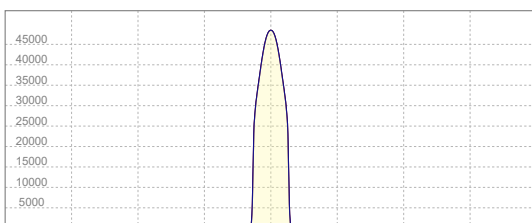

Peak Candela
48402 cd

Calculate Center Beam Intensities

$$\text{lux} = 48402 / \text{distance(m)}^2$$

$$\text{fc} = 48402 / \text{distance(ft)}^2$$

Key Measurements

Output

Total Lumen Output: 4979 lm

Peak Intensity: 48305 cd

Beam

Beam Angle (50%): 22.7°

Field Angle (10%): 25.4°

Cutoff Angle (2.5%): 26.7°

Color

Color Temperature: 6540 K

CRI: 92.1

TLCI: 93

TM30 R_F: 88.6

TM30 R_g: 103.1

Power Details

Efficacy: 21 Lumen/Watt

Power: 242 W

Supply Voltage: 116 V

Current: 2.09 A

Beam Details

Distance	3 m	5 m	10 m	15 m	20 m
Beam Width	1.2 m	2 m	4 m	6 m	8 m

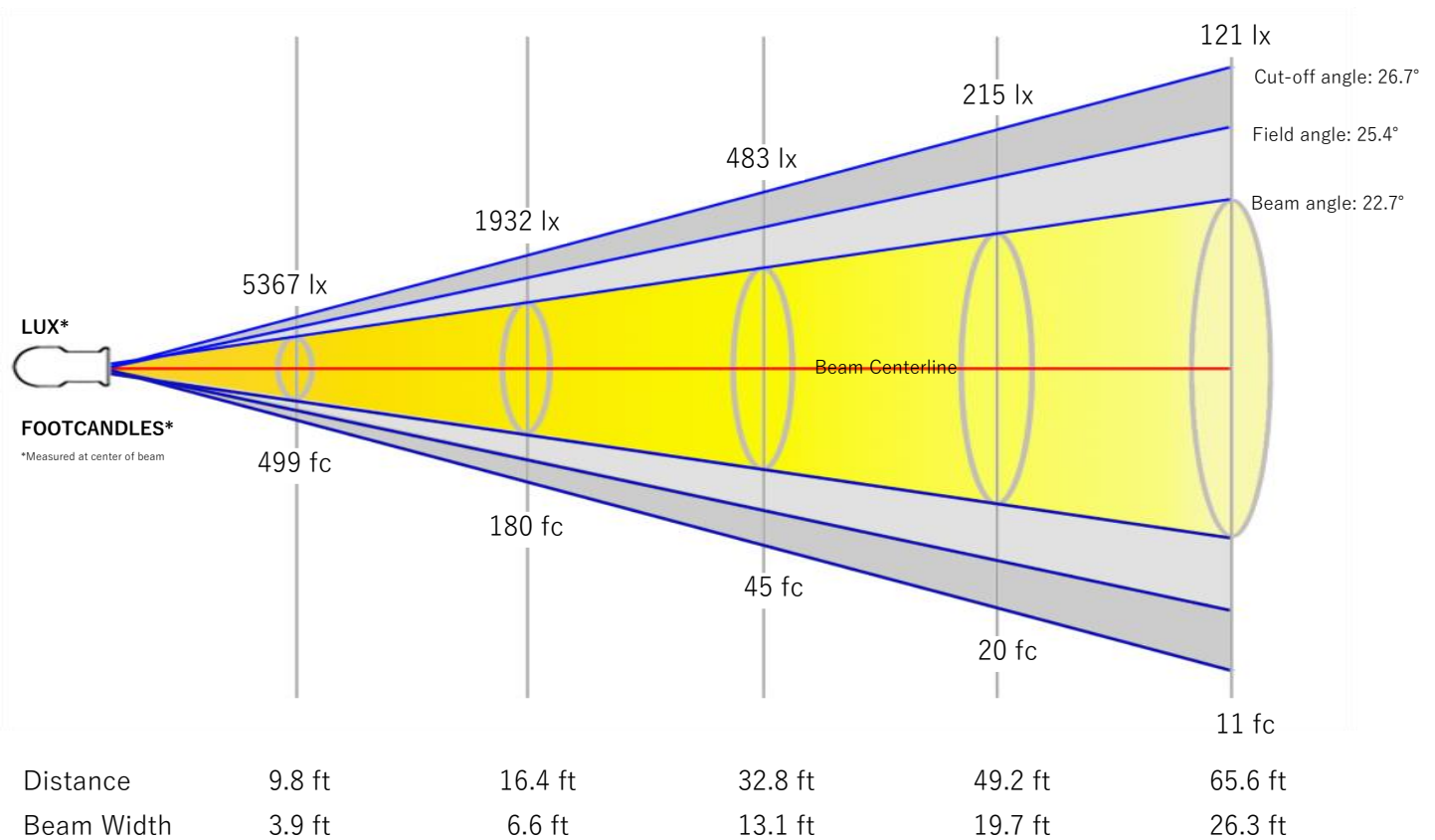

Beam Intensities from 1-20m

M	1	2	3	4	5	6	7	8	9	10	11	12	13	14	15	16	17	18	19	20
LX	48305	12076	5367	3019	1932	1342	986	755	596	483	399	335	286	246	215	189	167	149	134	121
FT	3.3	6.6	9.8	13.1	16.4	19.7	23	26.2	29.5	32.8	36.1	39.4	42.7	45.9	49.2	52.5	55.8	59.1	62.3	65.6
FC	4487.7	1121.9	498.6	280.5	179.5	124.7	91.6	70.1	55.4	44.9	37.1	31.2	26.6	22.9	19.9	17.5	15.5	13.9	12.4	11.2

Angular Distribution

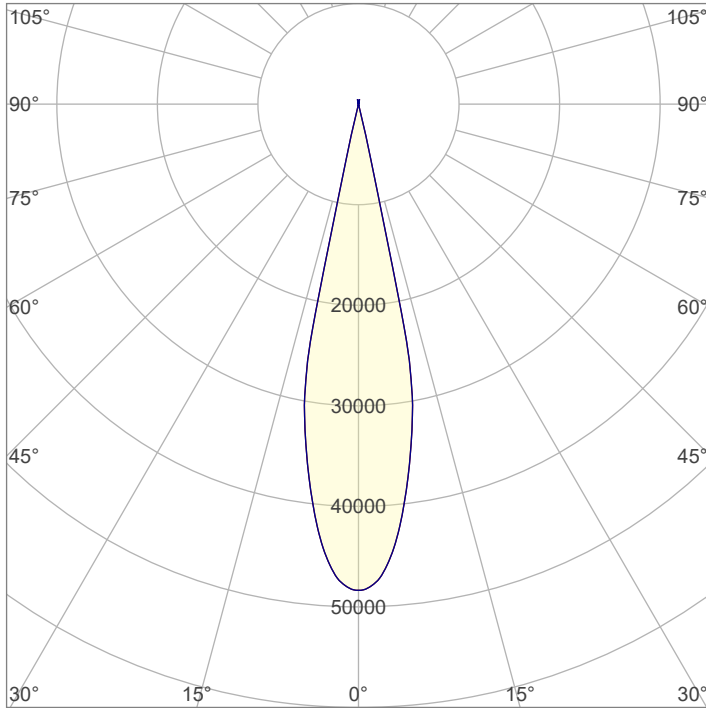

Beam Angle - 50%
22.7°
Field Angle - 10%
25.4°
Cutoff Angle - 2.5%
26.7°

ISO Diagrams

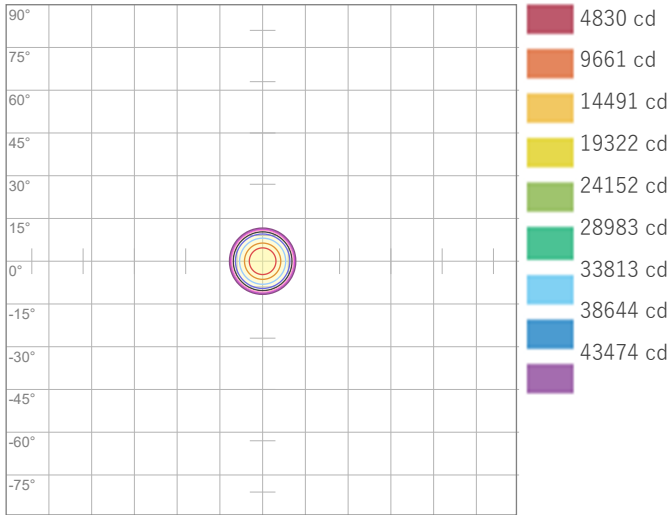

ISO Candela Diagram

Conditions:

Number of c-planes: 8

Candela at center: 48305 cd

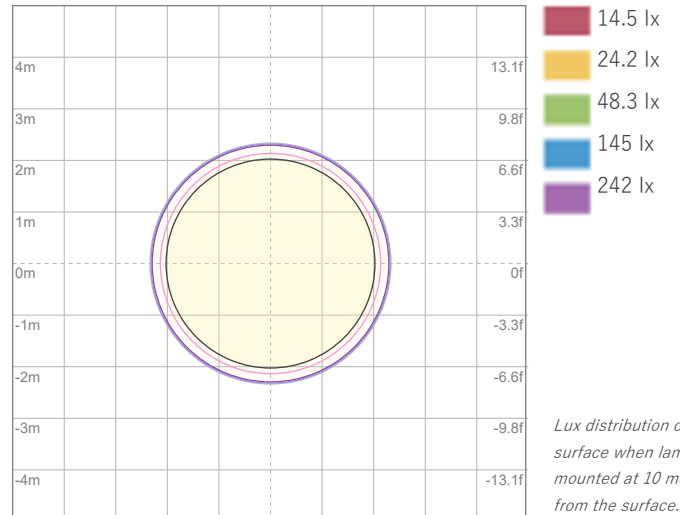

ISO LUX Diagram

Conditions:

Number of c-planes: 8

LUX at center: 483 lx

Lux distribution on a surface when lamp is mounted at 10 meters from the surface.

Linear Distribution

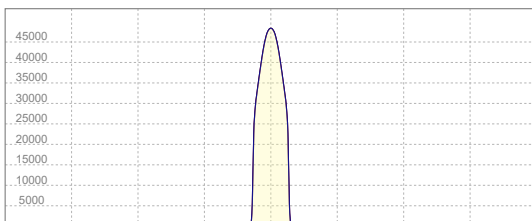

Peak Candela
48305 cd

Calculate Center Beam Intensities

$$\text{lux} = 48305 / \text{distance(m)}^2$$

$$\text{fc} = 48305 / \text{distance(ft)}^2$$

Key Measurements

Output

Total Lumen Output: 5387 lm

Peak Intensity: 53014 cd

Beam

Beam Angle (50%): 22.5°

Field Angle (10%): 25.3°

Cutoff Angle (2.5%): 26.4°

Color

Color Temperature: 8225 K

CRI: 83.8

TLCI: 69

TM30 R_F: 80.6

TM30 R_g: 95.0

Power Details

Efficacy: 22 Lumen/Watt

Power: 250 W

Supply Voltage: 117 V

Current: 2.14 A

Beam Details

Distance	3 m	5 m	10 m	15 m	20 m
Beam Width	1.2 m	2 m	4 m	6 m	8 m

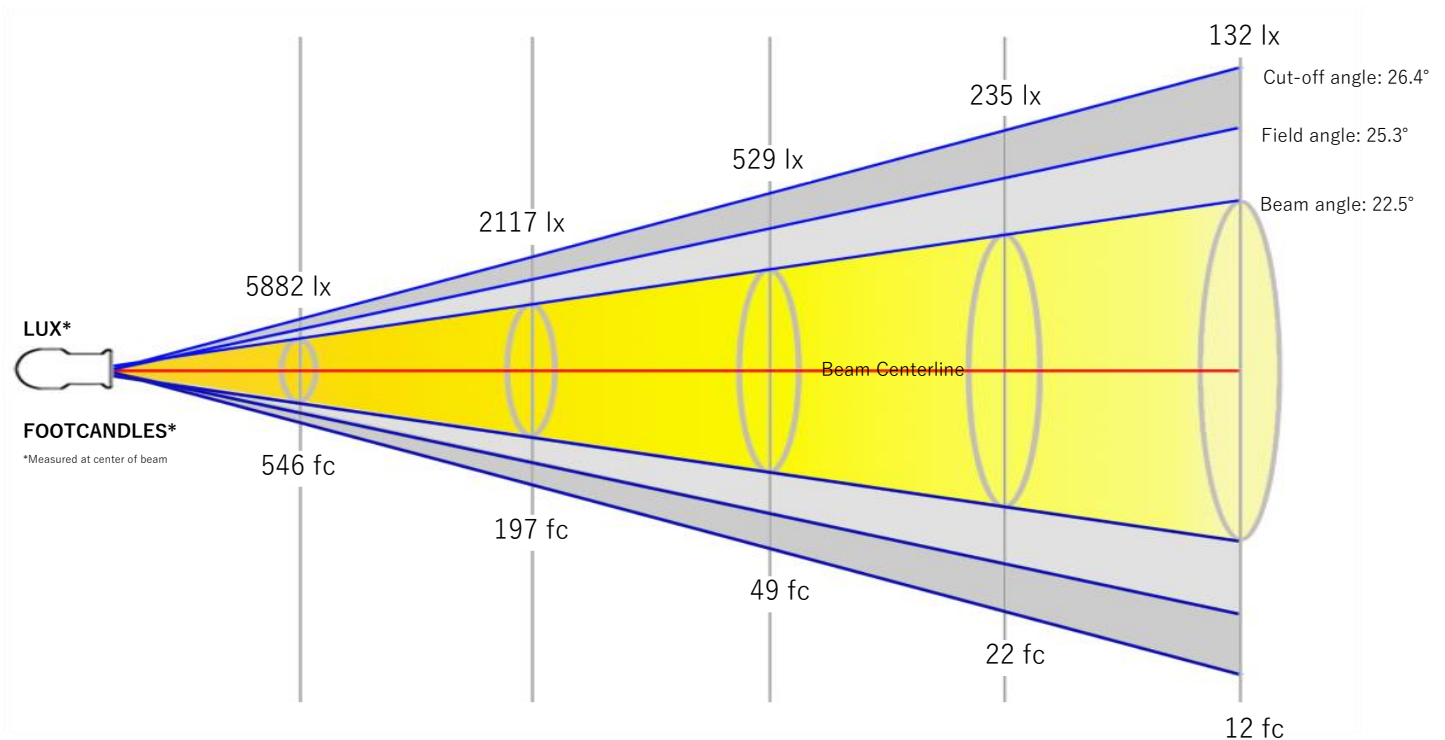

Distance	9.8 ft	16.4 ft	32.8 ft	49.2 ft	65.6 ft
Beam Width	3.9 ft	6.5 ft	13.1 ft	19.6 ft	26.1 ft

Beam Intensities from 1-20m

M	1	2	3	4	5	6	7	8	9	10	11	12	13	14	15	16	17	18	19	20
LX	52936	13234	5882	3309	2117	1470	1080	827	654	529	437	368	313	270	235	207	183	163	147	132
FT	3.3	6.6	9.8	13.1	16.4	19.7	23	26.2	29.5	32.8	36.1	39.4	42.7	45.9	49.2	52.5	55.8	59.1	62.3	65.6
FC	4917.9	1229.5	546.4	307.4	196.7	136.6	100.4	76.8	60.7	49.2	40.6	34.2	29.1	25.1	21.9	19.2	17	15.2	13.6	12.3

Angular Distribution

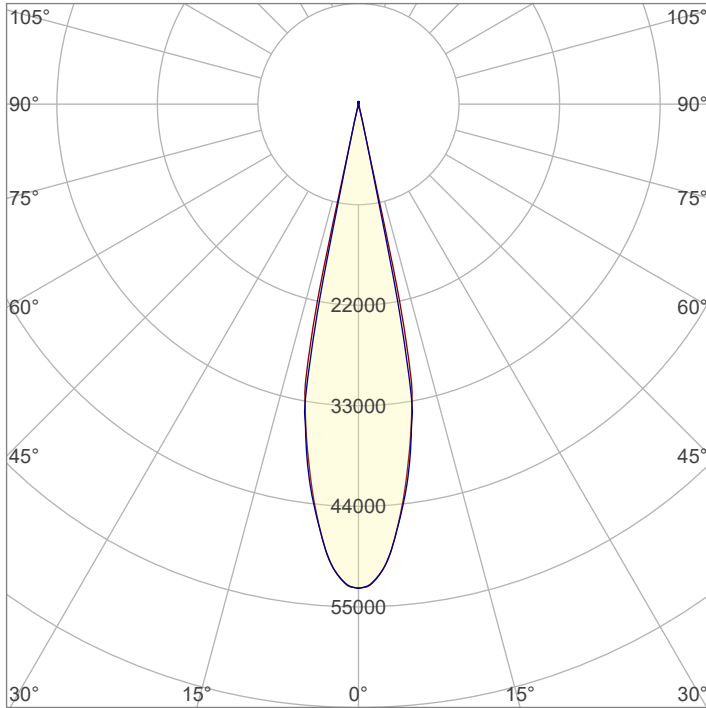

Beam Angle - 50%
22.5°
Field Angle - 10%
25.3°
Cutoff Angle - 2.5%
26.4°

ISO Diagrams

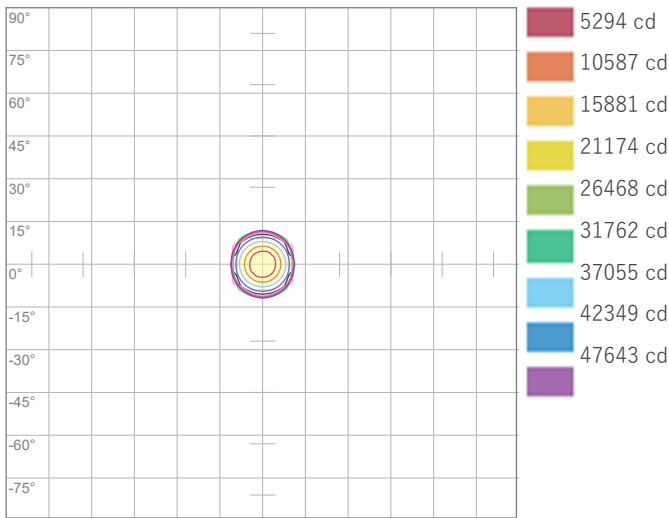

ISO Candela Diagram

Conditions:
Number of c-planes: 8
Candela at center: 52936 cd

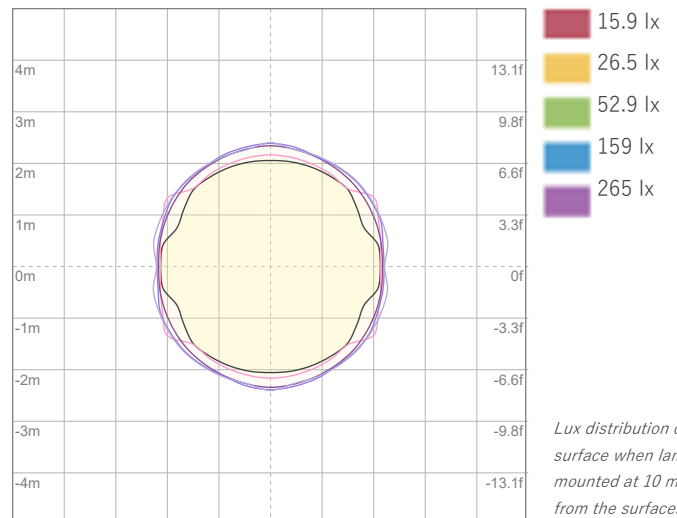

ISO LUX Diagram

Conditions:
Number of c-planes: 8
LUX at center: 529 lx

Lux distribution on a surface when lamp is mounted at 10 meters from the surface.

Linear Distribution

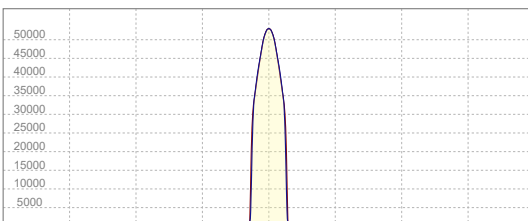

Peak Candela
53014 cd

Calculate Center Beam Intensities

$$\text{lux} = 53014 / \text{distance(m)}^2$$

$$\text{fc} = 53014 / \text{distance(ft)}^2$$

Key Measurements

Output

Total Lumen Output: 4923 lm

Peak Intensity: 24219 cd

Beam

Beam Angle (50%): 32°

Field Angle (10%): 36.4°

Cutoff Angle (2.5%): 38°

Color

Color Temperature: 6076 K

CRI: 91.1

TLCI: 94

TM30 R_F: 89.3

TM30 R_g: 105.7

Power Details

Efficacy: 21 Lumen/Watt

Power: 239 W

Supply Voltage: 117 V

Current: 2.04 A

Beam Details

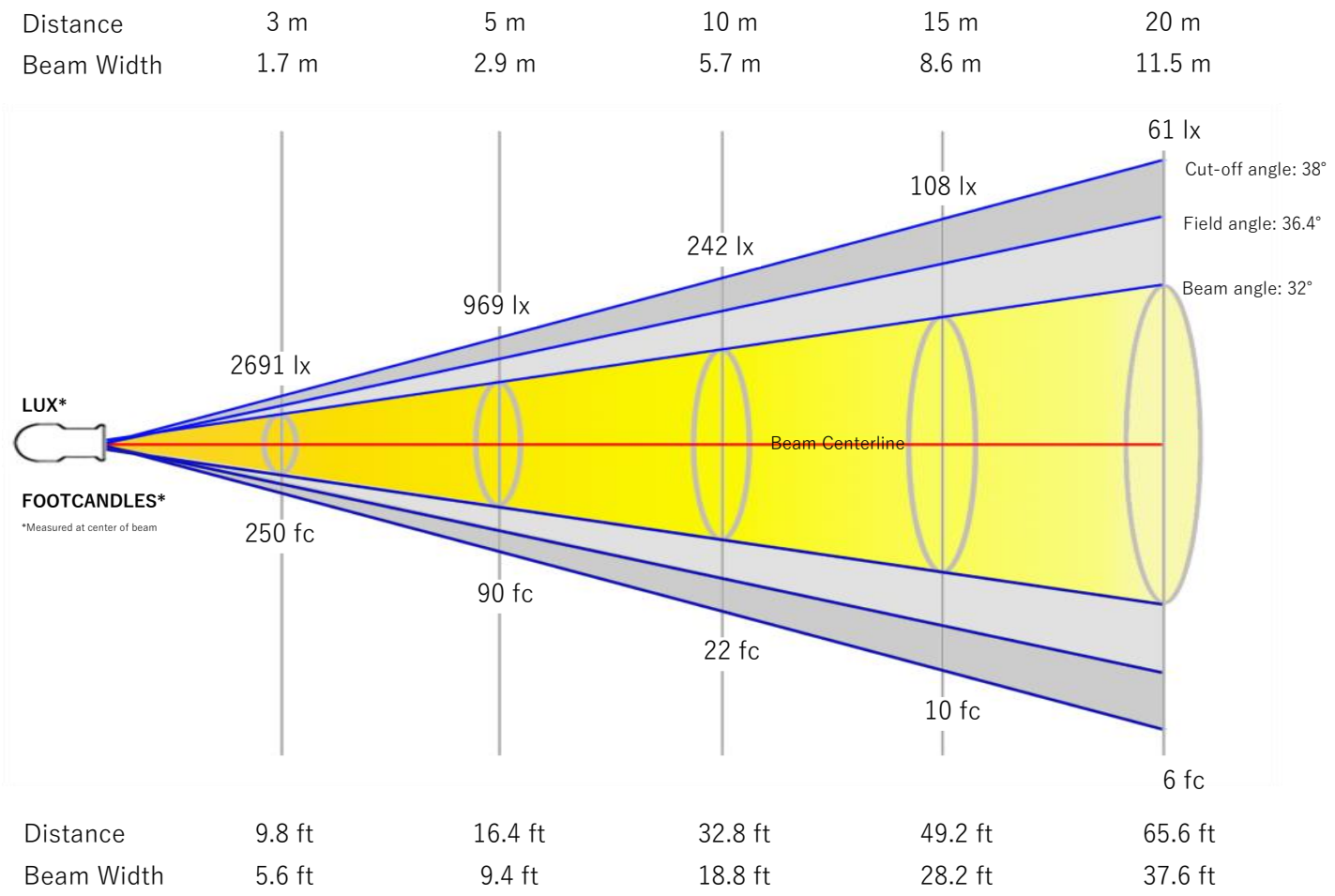

Beam Intensities from 1-20m

M	1	2	3	4	5	6	7	8	9	10	11	12	13	14	15	16	17	18	19	20
LX	24219	6055	2691	1514	969	673	494	378	299	242	200	168	143	124	108	95	84	75	67	61
FT	3.3	6.6	9.8	13.1	16.4	19.7	23	26.2	29.5	32.8	36.1	39.4	42.7	45.9	49.2	52.5	55.8	59.1	62.3	65.6
FC	2250	562.5	250	140.6	90	62.5	45.9	35.2	27.8	22.5	18.6	15.6	13.3	11.5	10	8.8	7.8	6.9	6.2	5.6

Angular Distribution

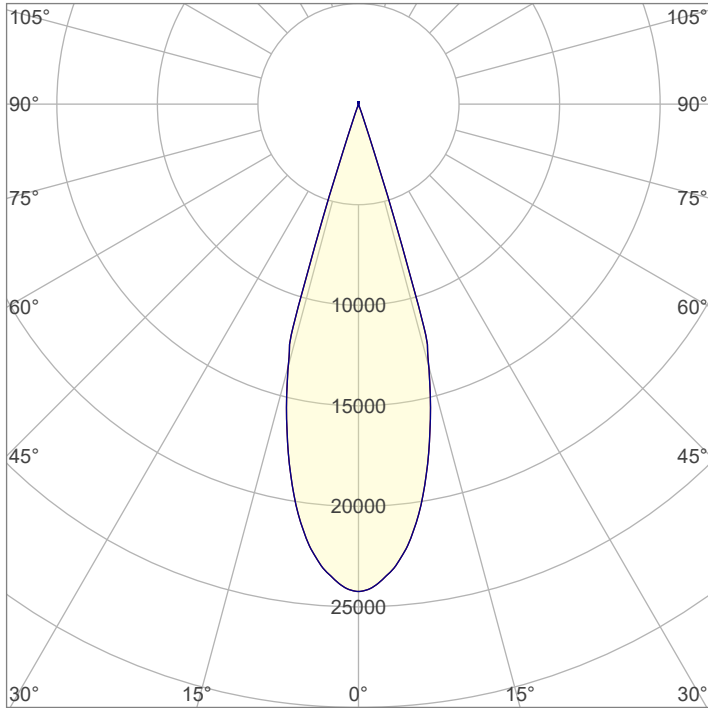

Beam Angle - 50%
32°
Field Angle - 10%
36.4°
Cutoff Angle - 2.5%
38°

ISO Diagrams

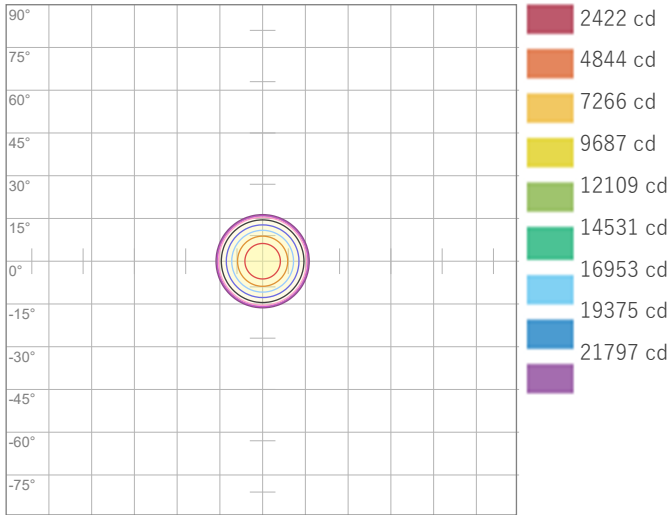

ISO Candela Diagram

Conditions:

Number of c-planes: 8

Candela at center: 24219 cd

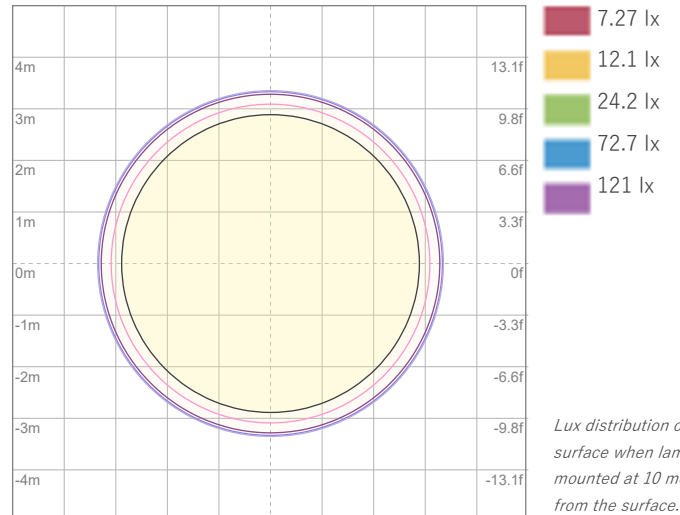

ISO LUX Diagram

Conditions:

Number of c-planes: 8

LUX at center: 242 lx

Lux distribution on a surface when lamp is mounted at 10 meters from the surface.

Linear Distribution

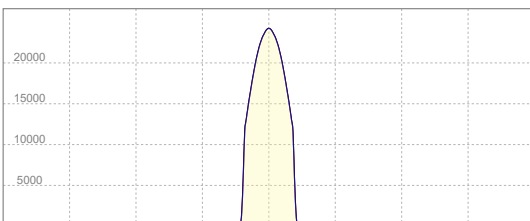

Peak Candela
24219 cd

Calculate Center Beam Intensities

$$\text{lux} = 24219 / \text{distance(m)}^2$$

$$\text{fc} = 24219 / \text{distance(ft)}^2$$

Key Measurements

Output

Total Lumen Output: 4956 lm

Peak Intensity: 24483 cd

Beam

Beam Angle (50%): 31.6°

Field Angle (10%): 36.5°

Cutoff Angle (2.5%): 38°

Color

Color Temperature: 2713 K

CRI: 89.0

TLCI: 93

TM30 R_F: 92.4

TM30 R_g: 107.0

Power Details

Efficacy: 20 Lumen/Watt

Power: 246 W

Supply Voltage: 116 V

Current: 2.12 A

Beam Details

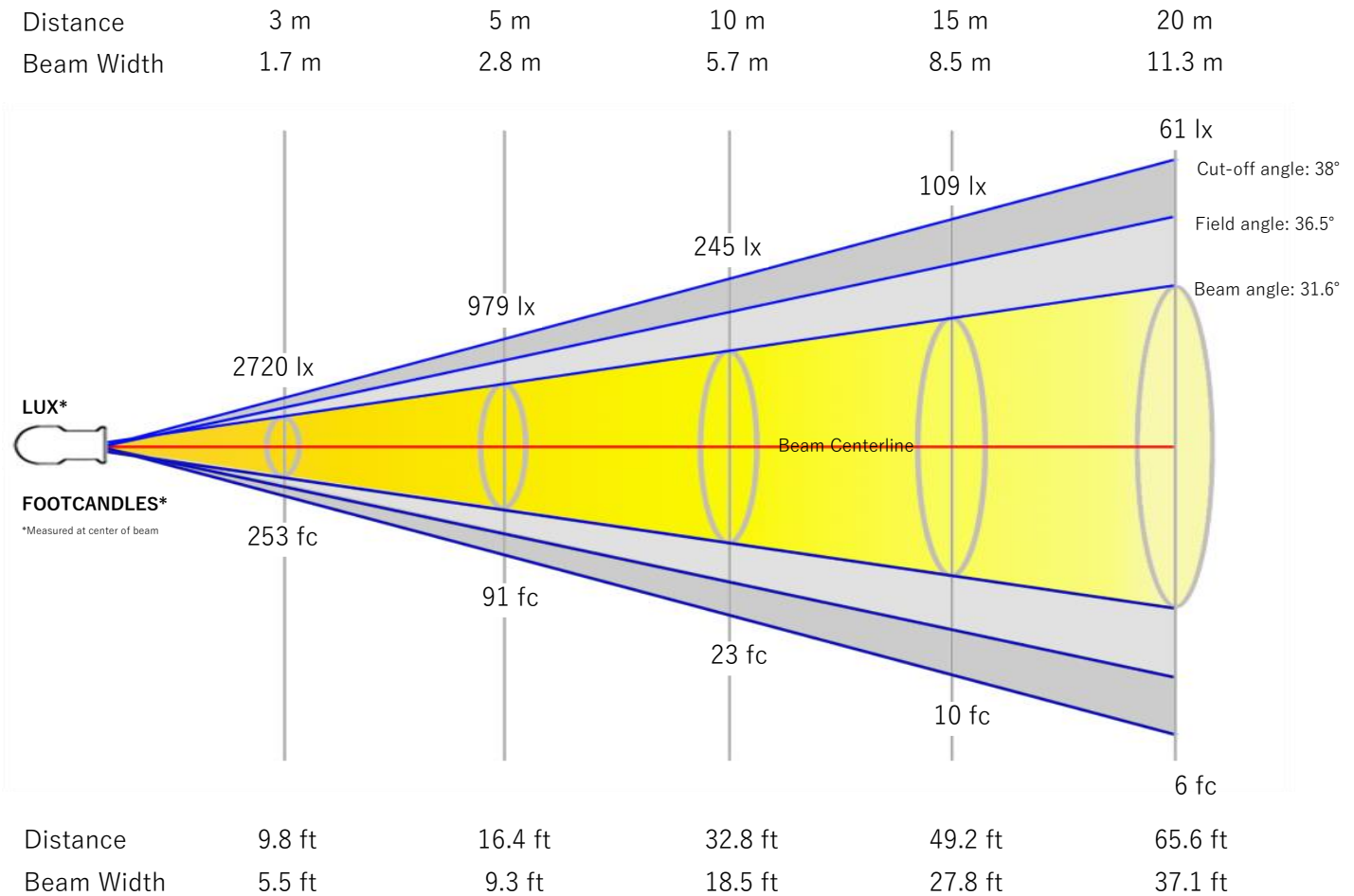

Beam Intensities from 1-20m

M	1	2	3	4	5	6	7	8	9	10	11	12	13	14	15	16	17	18	19	20
LX	24483	6121	2720	1530	979	680	500	383	302	245	202	170	145	125	109	96	85	76	68	61
FT	3.3	6.6	9.8	13.1	16.4	19.7	23	26.2	29.5	32.8	36.1	39.4	42.7	45.9	49.2	52.5	55.8	59.1	62.3	65.6
FC	2274.5	568.6	252.7	142.2	91	63.2	46.4	35.5	28.1	22.7	18.8	15.8	13.5	11.6	10.1	8.9	7.9	7	6.3	5.7

Angular Distribution

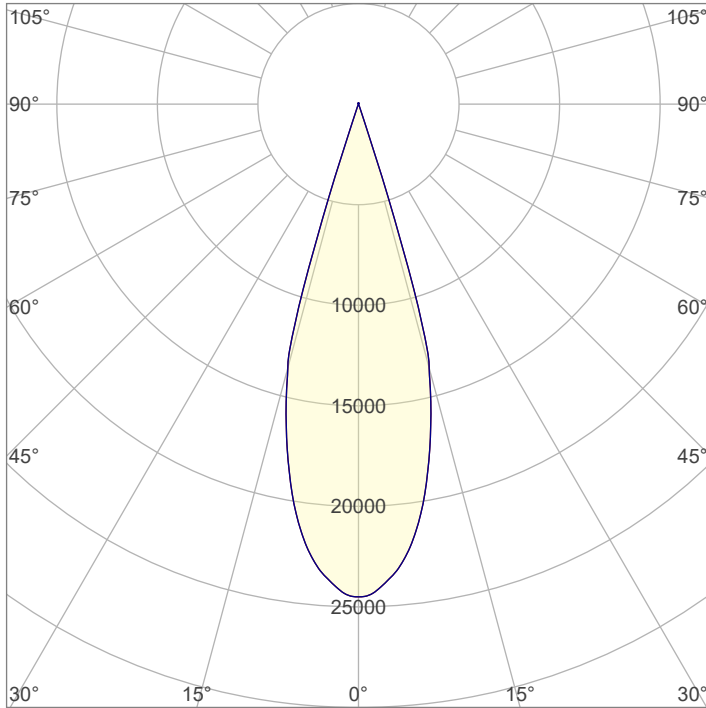

Beam Angle - 50%
31.6°
Field Angle - 10%
36.5°
Cutoff Angle - 2.5%
38°

ISO Diagrams

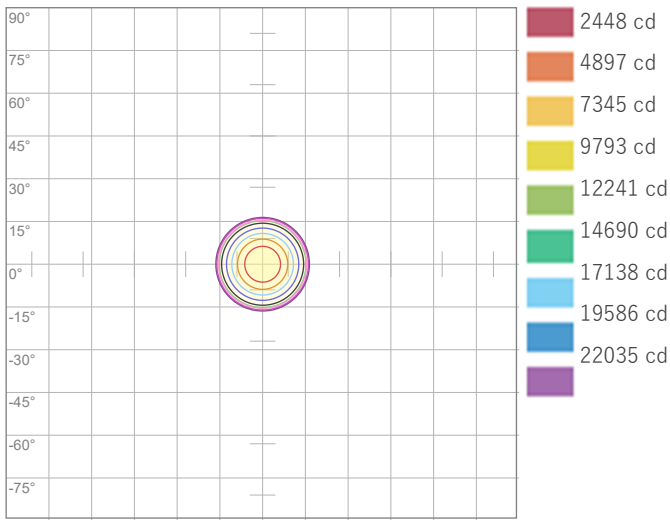

ISO Candela Diagram

Conditions:
Number of c-planes: 8
Candela at center: 24483 cd

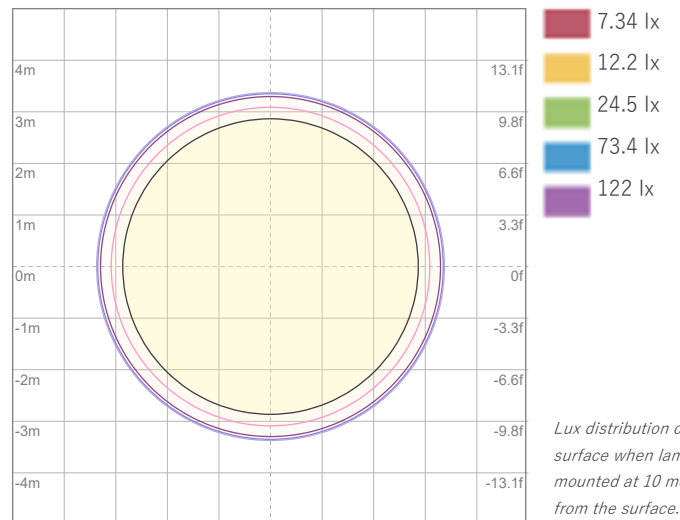

ISO LUX Diagram

Conditions:
Number of c-planes: 8
LUX at center: 245 lx

Lux distribution on a surface when lamp is mounted at 10 meters from the surface.

Linear Distribution

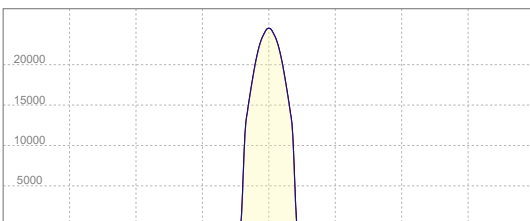

Peak Candela
24483 cd

Calculate Center Beam Intensities

$$\text{lux} = 24483 / \text{distance(m)}^2$$

$$\text{fc} = 24483 / \text{distance(ft)}^2$$

Key Measurements

Output

Total Lumen Output: 5183 lm

Peak Intensity: 25766 cd

Beam

Beam Angle (50%): 31.7°

Field Angle (10%): 36.4°

Cutoff Angle (2.5%): 37.6°

Color

Color Temperature: 3242 K

CRI: 90.7

TLCI: 94

TM30 R_F: 92.0

TM30 R_g: 106.1

Power Details

Efficacy: 21 Lumen/Watt

Power: 244 W

Supply Voltage: 116 V

Current: 2.10 A

Beam Details

Distance	3 m	5 m	10 m	15 m	20 m
Beam Width	1.7 m	2.8 m	5.7 m	8.5 m	11.4 m

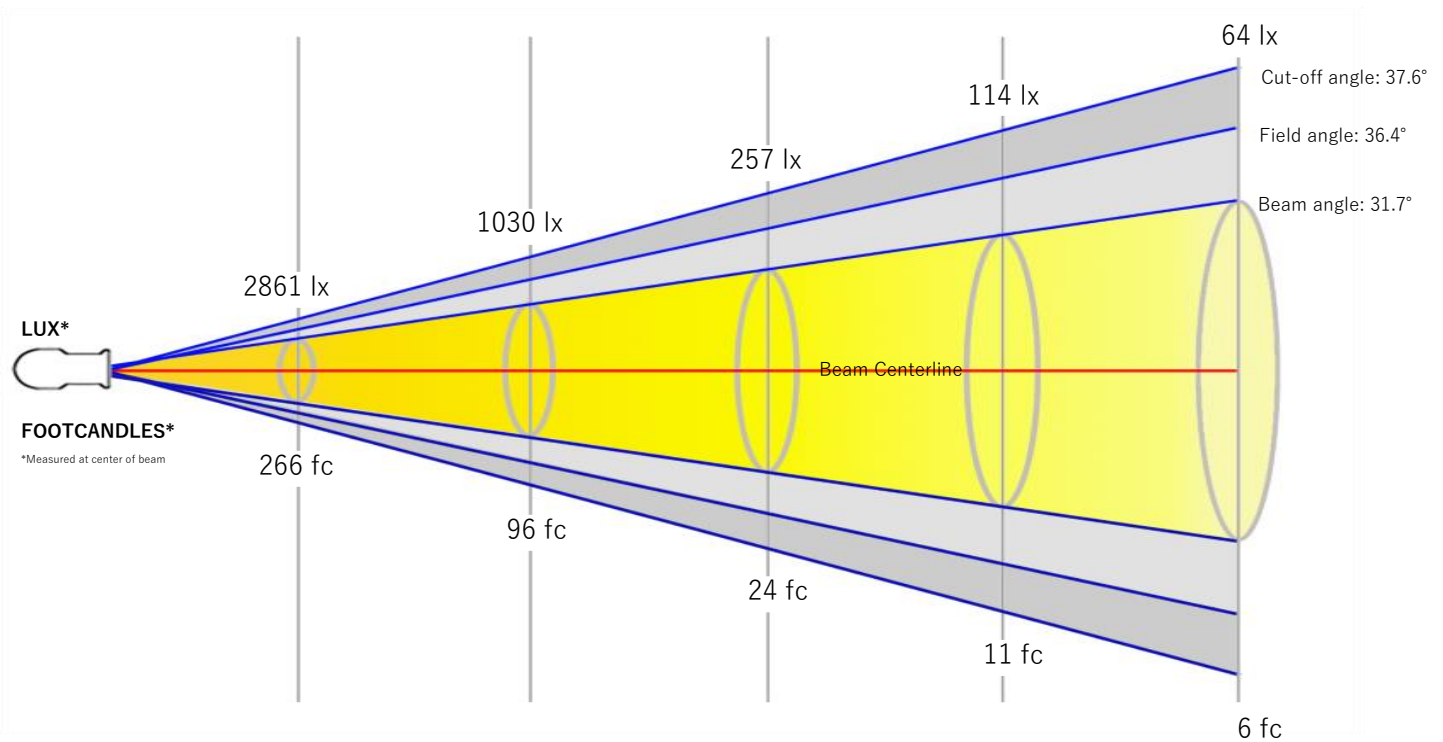

Distance	9.8 ft	16.4 ft	32.8 ft	49.2 ft	65.6 ft
Beam Width	5.6 ft	9.3 ft	18.7 ft	28 ft	37.3 ft

Beam Intensities from 1-20m

M	1	2	3	4	5	6	7	8	9	10	11	12	13	14	15	16	17	18	19	20
LX	25746	6436	2861	1609	1030	715	525	402	318	257	213	179	152	131	114	101	89	79	71	64
FT	3.3	6.6	9.8	13.1	16.4	19.7	23	26.2	29.5	32.8	36.1	39.4	42.7	45.9	49.2	52.5	55.8	59.1	62.3	65.6
FC	2391.8	598	265.8	149.5	95.7	66.4	48.8	37.4	29.5	23.9	19.8	16.6	14.2	12.2	10.6	9.3	8.3	7.4	6.6	6

Angular Distribution

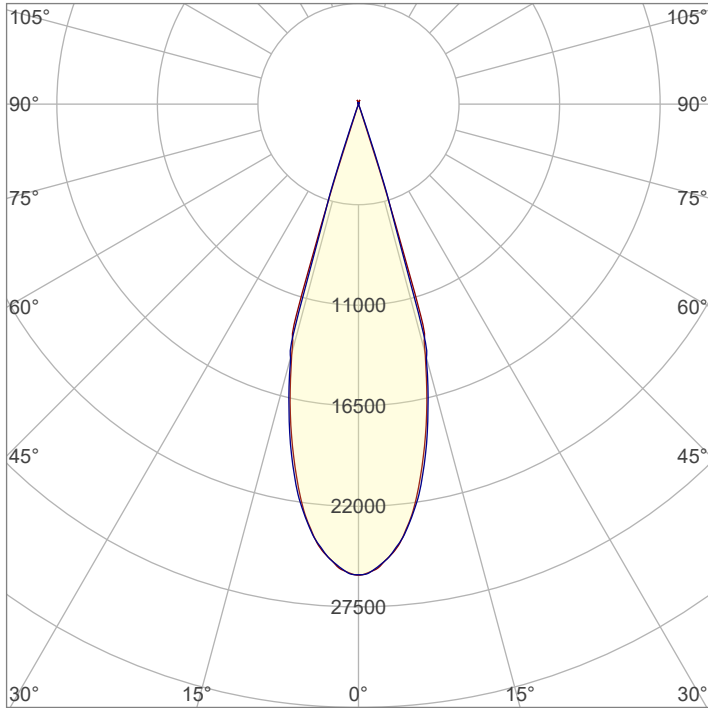

Beam Angle - 50%
31.7°
Field Angle - 10%
36.4°
Cutoff Angle - 2.5%
37.6°

ISO Diagrams

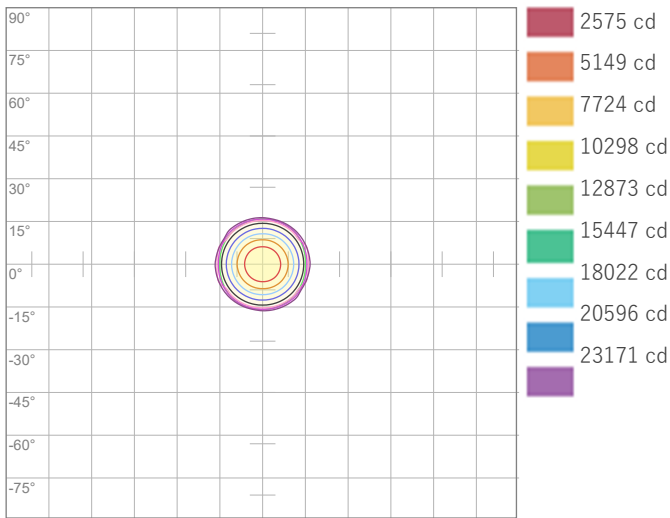

ISO Candela Diagram

Conditions:

Number of c-planes: 8

Candela at center: 25746 cd

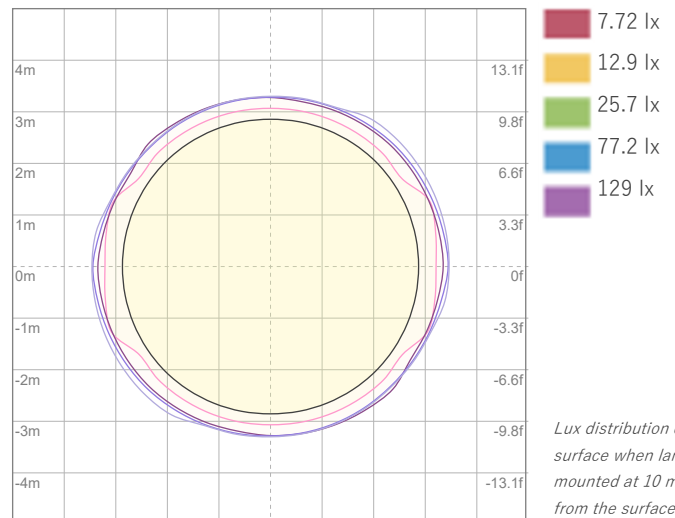

ISO LUX Diagram

Lux distribution on a surface when lamp is mounted at 10 meters from the surface.

Conditions:

Number of c-planes: 8

LUX at center: 257 lx

Linear Distribution

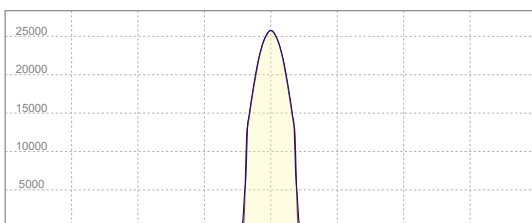

Peak Candela
25766 cd

Calculate Center Beam Intensities

$$\text{lux} = 25766 / \text{distance(m)}^2$$

$$\text{fc} = 25766 / \text{distance(ft)}^2$$

Key Measurements

Output

Total Lumen Output: 4917 lm

Peak Intensity: 24158 cd

Beam

Beam Angle (50%): 31.9°

Field Angle (10%): 36.5°

Cutoff Angle (2.5%): 37.7°

Color

Color Temperature: 5660 K

CRI: 90.1

TLCI: 93

TM30 R_F: 89.4

TM30 R_g: 106.6

Power Details

Efficacy: 20 Lumen/Watt

Power: 241 W

Supply Voltage: 116 V

Current: 2.08 A

Beam Details

Distance	3 m	5 m	10 m	15 m	20 m
Beam Width	1.7 m	2.9 m	5.7 m	8.6 m	11.4 m

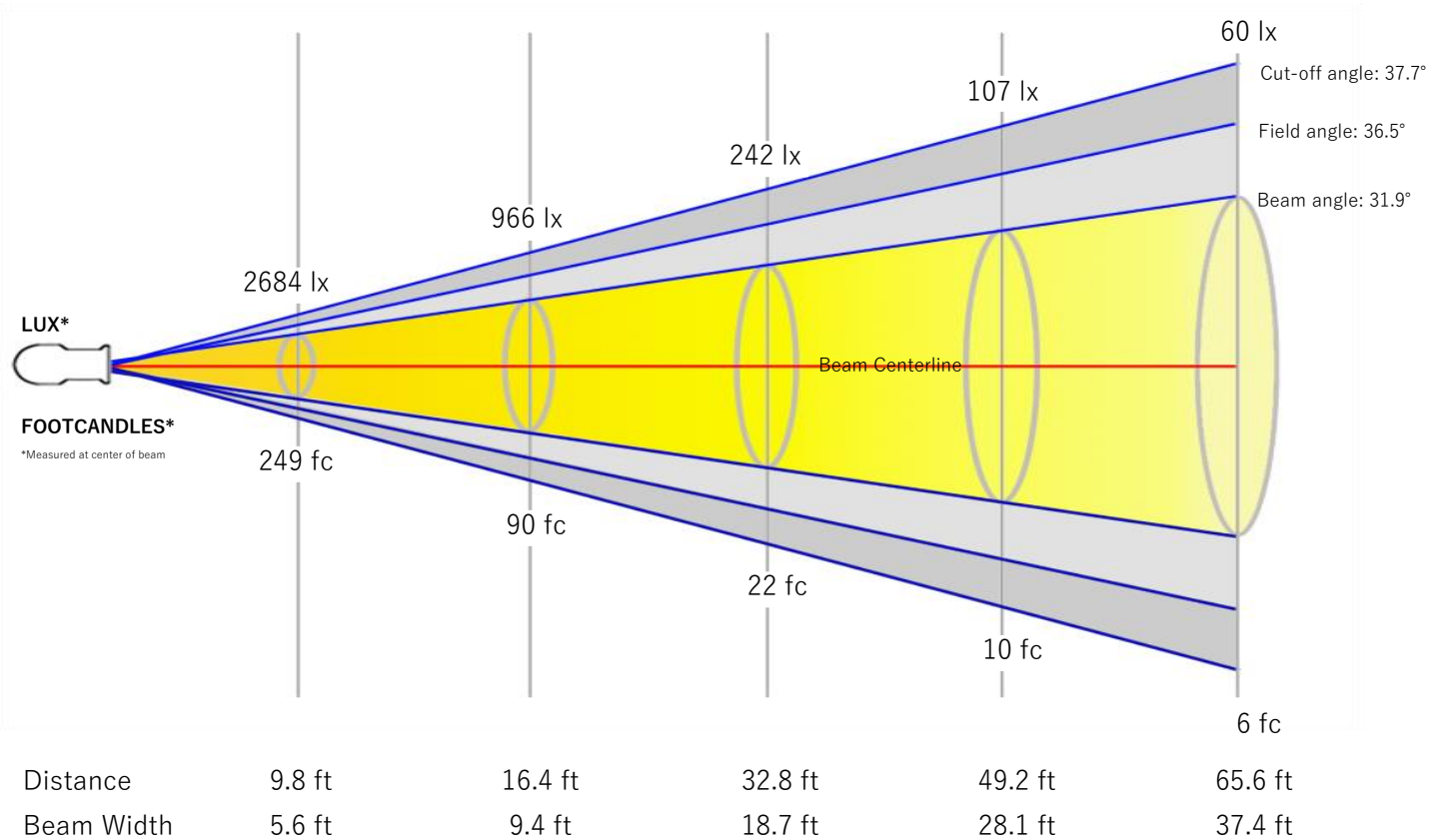

Beam Intensities from 1-20m

M	1	2	3	4	5	6	7	8	9	10	11	12	13	14	15	16	17	18	19	20
LX	24158	6040	2684	1510	966	671	493	377	298	242	200	168	143	123	107	94	84	75	67	60
FT	3.3	6.6	9.8	13.1	16.4	19.7	23	26.2	29.5	32.8	36.1	39.4	42.7	45.9	49.2	52.5	55.8	59.1	62.3	65.6
FC	2244.4	561.1	249.4	140.3	89.8	62.3	45.8	35.1	27.7	22.4	18.5	15.6	13.3	11.5	10	8.8	7.8	6.9	6.2	5.6

Angular Distribution

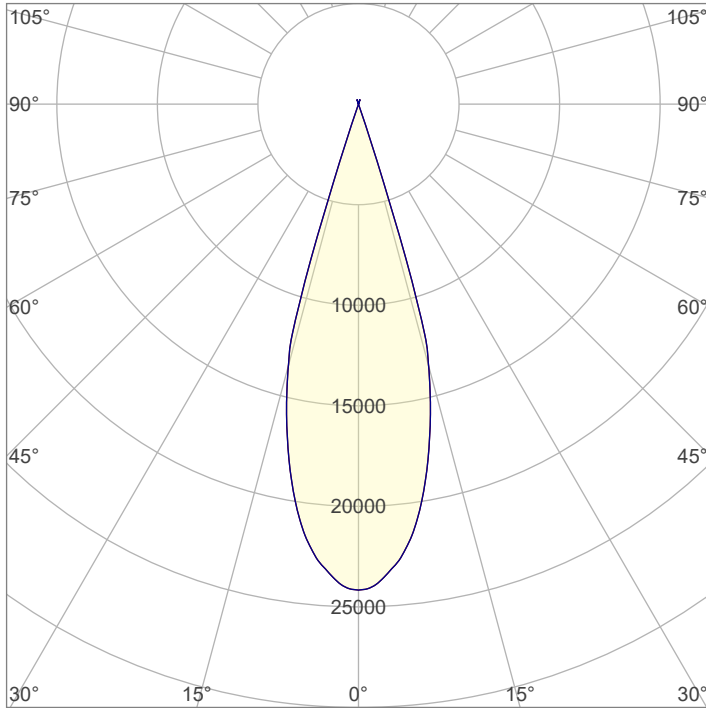

Beam Angle - 50%
31.9°
Field Angle - 10%
36.5°
Cutoff Angle - 2.5%
37.7°

ISO Diagrams

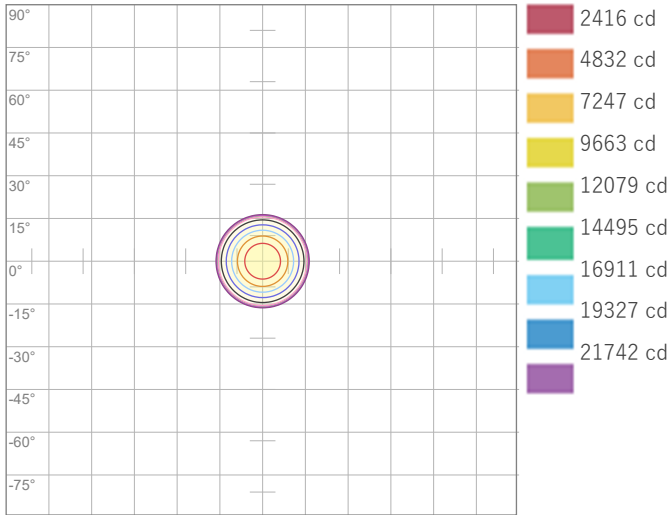

ISO Candela Diagram

Conditions:
Number of c-planes: 8
Candela at center: 24158 cd

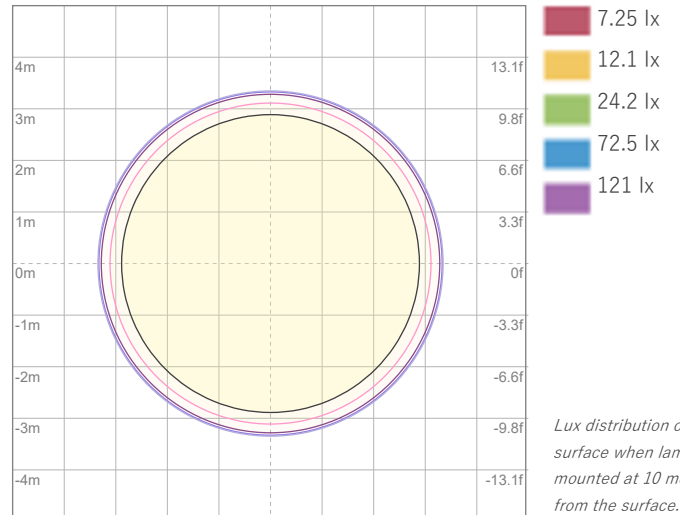

ISO LUX Diagram

Conditions:
Number of c-planes: 8
LUX at center: 242 lx

Lux distribution on a surface when lamp is mounted at 10 meters from the surface.

Linear Distribution

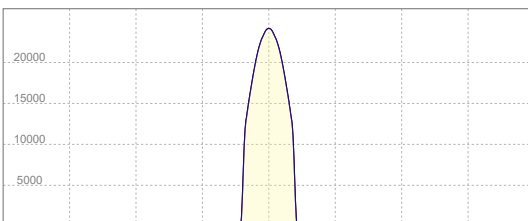

Peak Candela
24158 cd

Calculate Center Beam Intensities

$$\text{lux} = 24158 / \text{distance(m)}^2$$

$$\text{fc} = 24158 / \text{distance(ft)}^2$$

Key Measurements

Output

Total Lumen Output: 4954 lm

Peak Intensity: 24479 cd

Beam

Beam Angle (50%): 31.8°

Field Angle (10%): 36.2°

Cutoff Angle (2.5%): 37.5°

Color

Color Temperature: 6550 K

CRI: 92.1

TLCI: 93

TM30 R_F: 88.6

TM30 R_g: 103.0

Power Details

Efficacy: 21 Lumen/Watt

Power: 240 W

Supply Voltage: 117 V

Current: 2.05 A

Beam Details

Distance	3 m	5 m	10 m	15 m	20 m
Beam Width	1.7 m	2.9 m	5.7 m	8.6 m	11.4 m

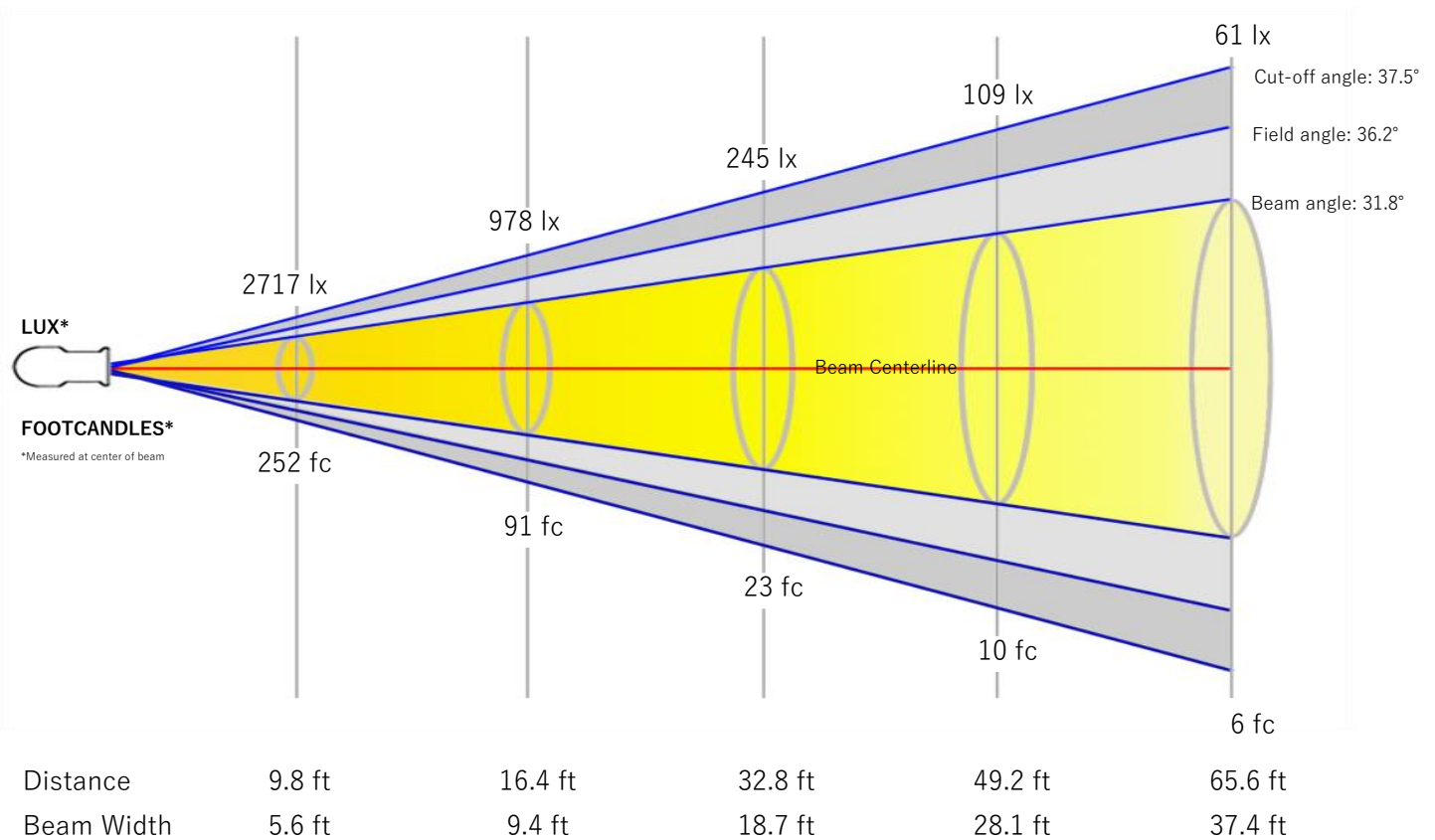

Beam Intensities from 1-20m

M	1	2	3	4	5	6	7	8	9	10	11	12	13	14	15	16	17	18	19	20
LX	24451	6113	2717	1528	978	679	499	382	302	245	202	170	145	125	109	96	85	75	68	61
FT	3.3	6.6	9.8	13.1	16.4	19.7	23	26.2	29.5	32.8	36.1	39.4	42.7	45.9	49.2	52.5	55.8	59.1	62.3	65.6
FC	2271.6	567.9	252.4	142	90.9	63.1	46.4	35.5	28	22.7	18.8	15.8	13.4	11.6	10.1	8.9	7.9	7	6.3	5.7

Angular Distribution

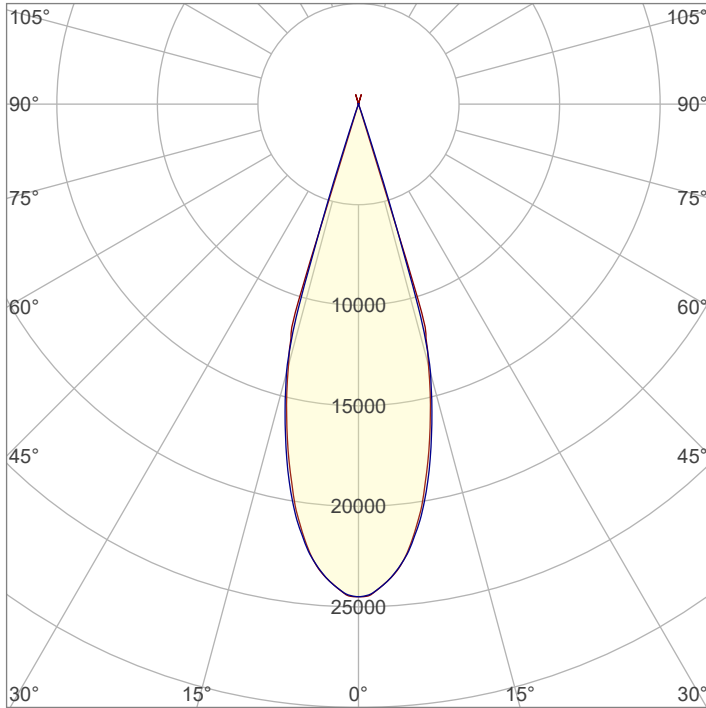

Beam Angle - 50%
31.8°
Field Angle - 10%
36.2°
Cutoff Angle - 2.5%
37.5°

ISO Diagrams

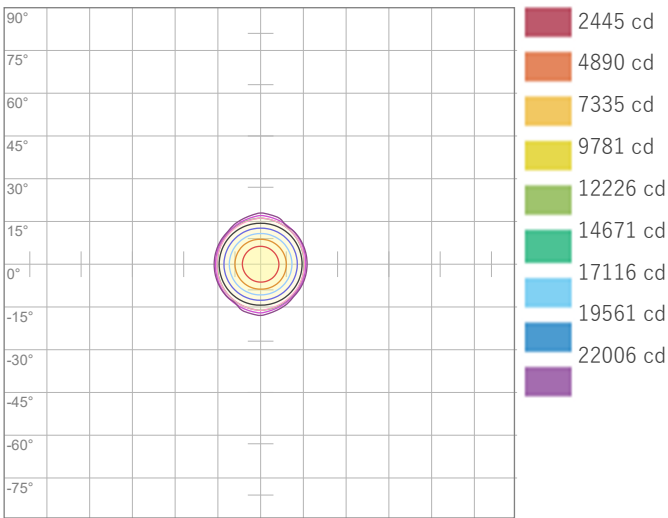

ISO Candela Diagram

Conditions:

Number of c-planes: 8

Candela at center: 24451 cd

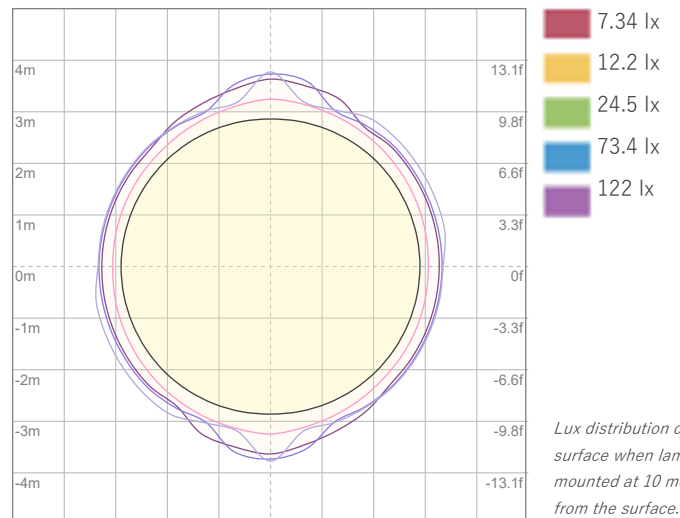

ISO LUX Diagram

Conditions:

Number of c-planes: 8

LUX at center: 245 lx

Lux distribution on a surface when lamp is mounted at 10 meters from the surface.

Linear Distribution

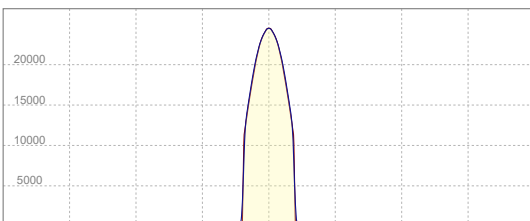

Peak Candela
24479 cd

Calculate Center Beam Intensities

$$\text{lux} = 24479 / \text{distance(m)}^2$$

$$\text{fc} = 24479 / \text{distance(ft)}^2$$

Key Measurements

Output

Total Lumen Output: 5325 lm

Peak Intensity: 26417 cd

Beam

Beam Angle (50%): 31.8°

Field Angle (10%): 36.4°

Cutoff Angle (2.5%): 37.4°

Color

Color Temperature: 8256 K

CRI: 83.8

TLCI: 69

TM30 R_F: 80.5

TM30 R_g: 95.0

Power Details

Efficacy: 22 Lumen/Watt

Power: 247 W

Supply Voltage: 116 V

Current: 2.13 A

Beam Details

Distance	3 m	5 m	10 m	15 m	20 m
Beam Width	1.7 m	2.9 m	5.7 m	8.6 m	11.4 m

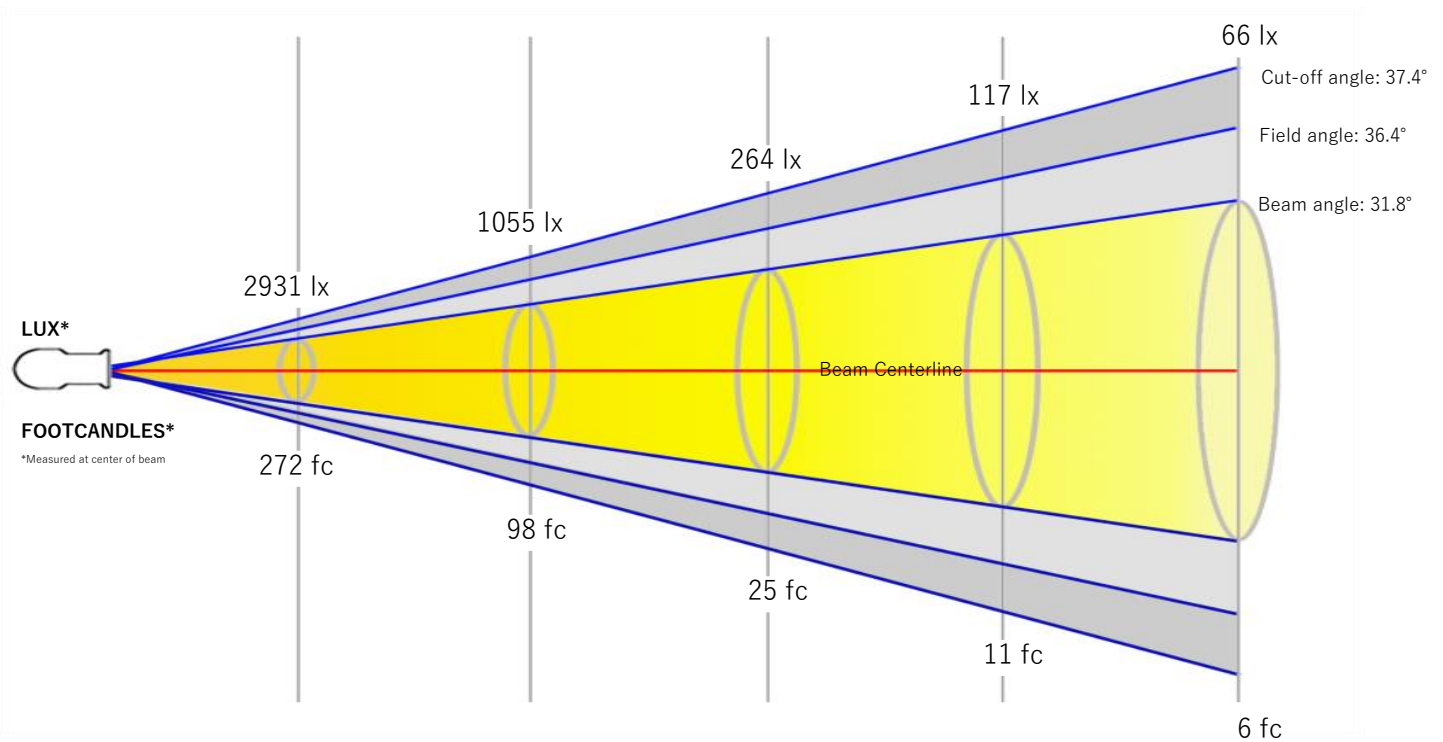

Distance	9.8 ft	16.4 ft	32.8 ft	49.2 ft	65.6 ft
Beam Width	5.6 ft	9.4 ft	18.7 ft	28.1 ft	37.4 ft

Beam Intensities from 1-20m

M	1	2	3	4	5	6	7	8	9	10	11	12	13	14	15	16	17	18	19	20
LX	26382	6596	2931	1649	1055	733	538	412	326	264	218	183	156	135	117	103	91	81	73	66
FT	3.3	6.6	9.8	13.1	16.4	19.7	23	26.2	29.5	32.8	36.1	39.4	42.7	45.9	49.2	52.5	55.8	59.1	62.3	65.6
FC	2451	612.7	272.3	153.2	98	68.1	50	38.3	30.3	24.5	20.3	17	14.5	12.5	10.9	9.6	8.5	7.6	6.8	6.1

Angular Distribution

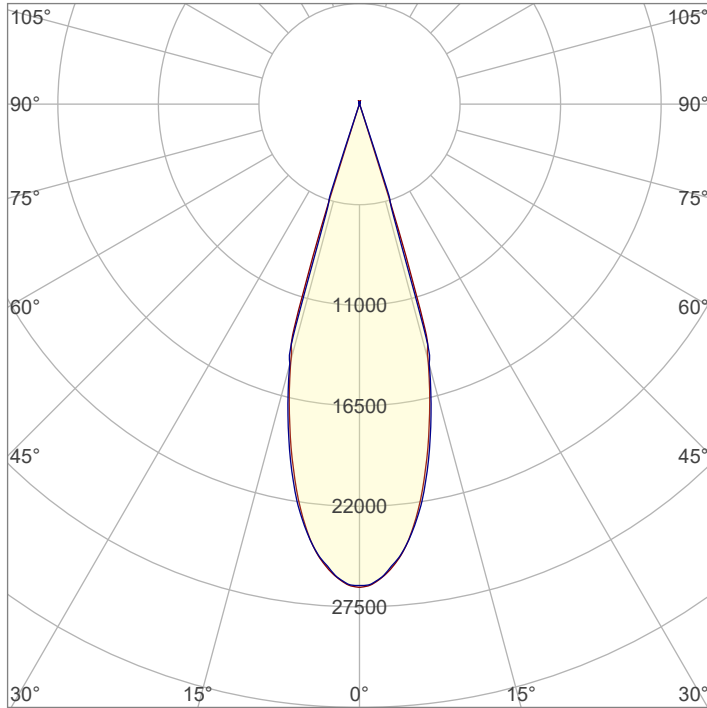

Beam Angle - 50%
31.8°
Field Angle - 10%
36.4°
Cutoff Angle - 2.5%
37.4°

ISO Diagrams

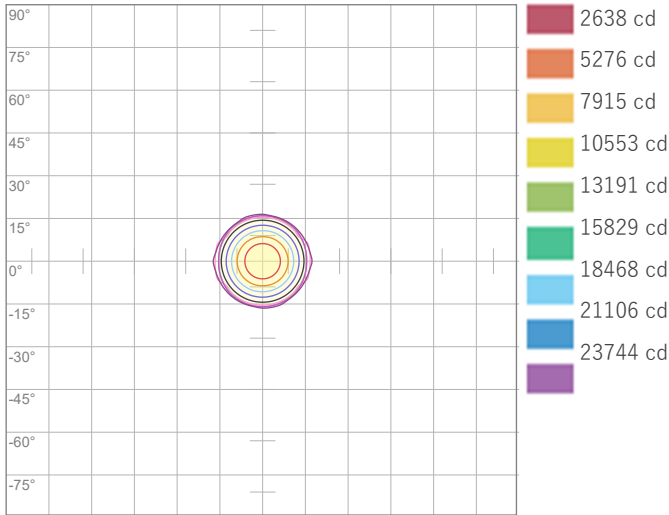

ISO Candela Diagram

Conditions:

Number of c-planes: 8

Candela at center: 26382 cd

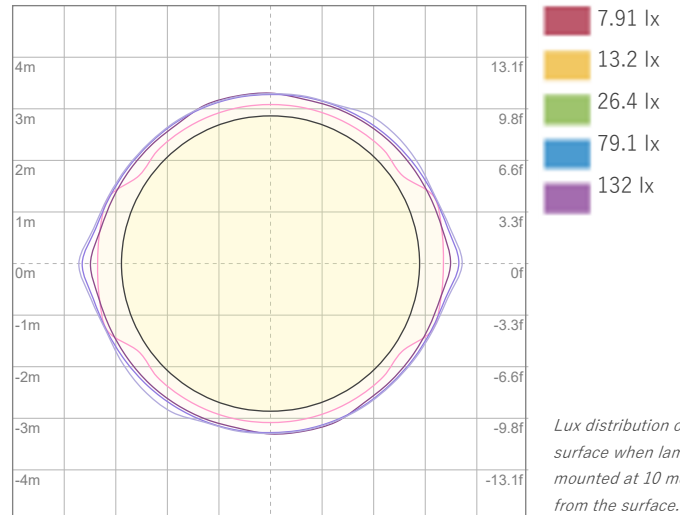

ISO LUX Diagram

Conditions:

Number of c-planes: 8

LUX at center: 264 lx

Lux distribution on a surface when lamp is mounted at 10 meters from the surface.

Linear Distribution

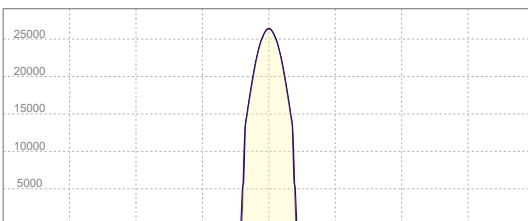

Peak Candela
26417 cd

Calculate Center Beam Intensities

$$\text{lux} = 26417 / \text{distance(m)}^2$$

$$\text{fc} = 26417 / \text{distance(ft)}^2$$

Key Measurements

Output

Total Lumen Output: 5583 lm

Peak Intensity: 16110 cd

Beam

Beam Angle (50%): 37°

Field Angle (10%): 49.1°

Cutoff Angle (2.5%): 50.3°

Color

Color Temperature: 6047 K

CRI: 91.5

TLCI: 94

TM30 R_F: 89.5

TM30 R_g: 105.4

Power Details

Efficacy: 23 Lumen/Watt

Power: 239 W

Supply Voltage: 117 V

Current: 2.04 A

Beam Details

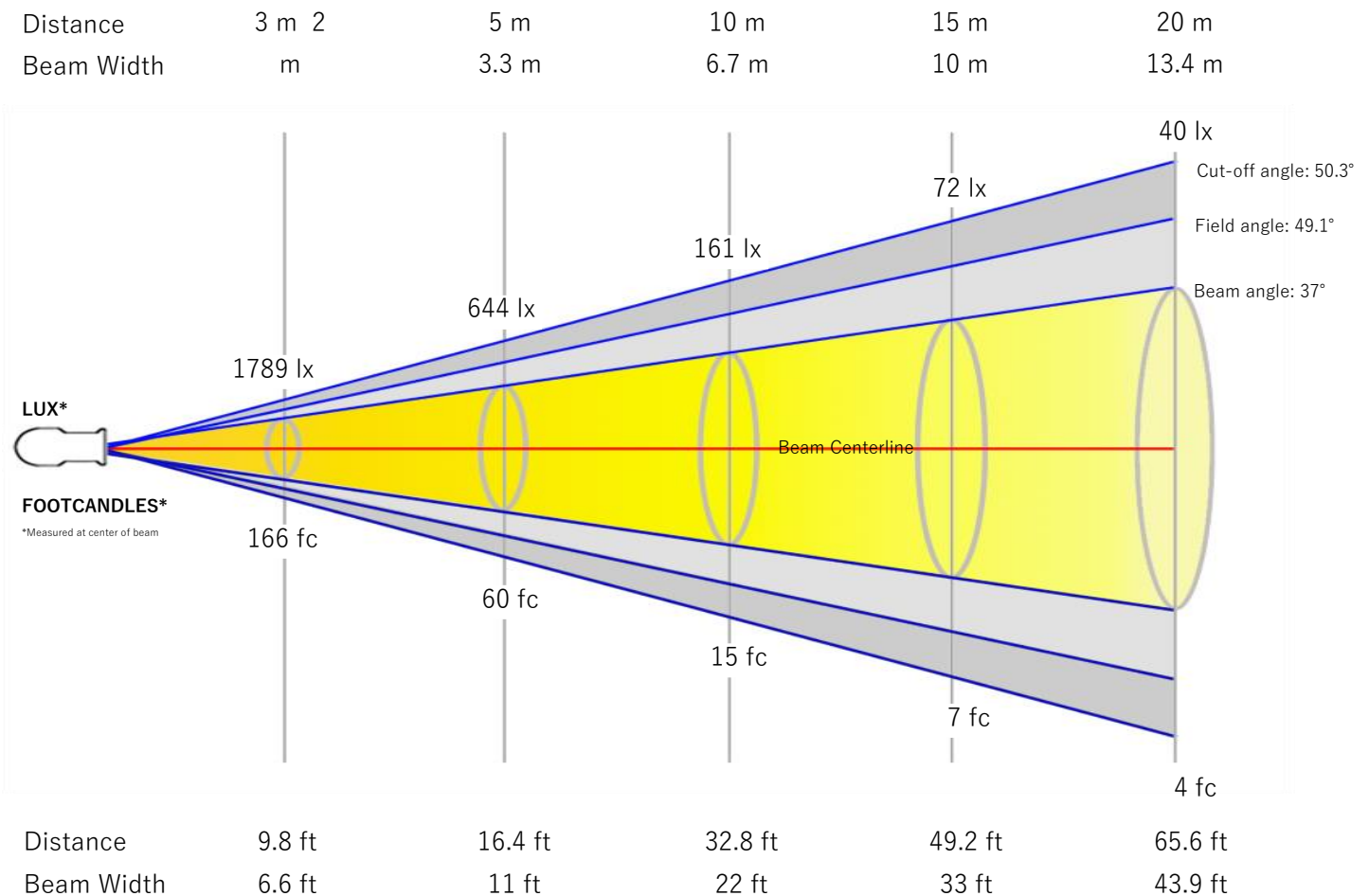

Beam Intensities from 1-20m

M	1	2	3	4	5	6	7	8	9	10	11	12	13	14	15	16	17	18	19	20
LX	16100	4025	1789	1006	644	447	329	252	199	161	133	112	95	82	72	63	56	50	45	40
FT	3.3	6.6	9.8	13.1	16.4	19.7	23	26.2	29.5	32.8	36.1	39.4	42.7	45.9	49.2	52.5	55.8	59.1	62.3	65.6
FC	1495.7	373.9	166.2	93.5	59.8	41.5	30.5	23.4	18.5	15	12.4	10.4	8.9	7.6	6.6	5.8	5.2	4.6	4.1	3.7

Angular Distribution

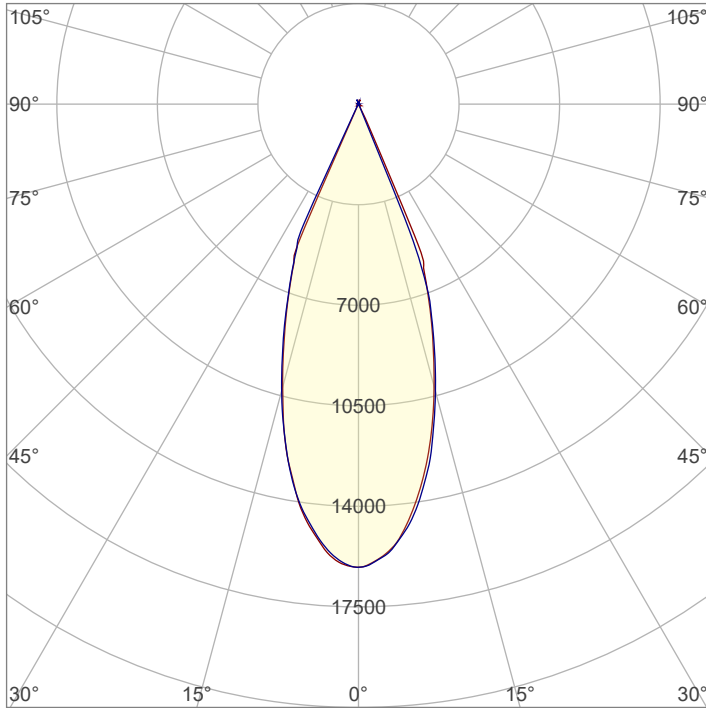

Beam Angle - 50%
37°
Field Angle - 10%
49.1°
Cutoff Angle - 2.5%
50.3°

ISO Diagrams

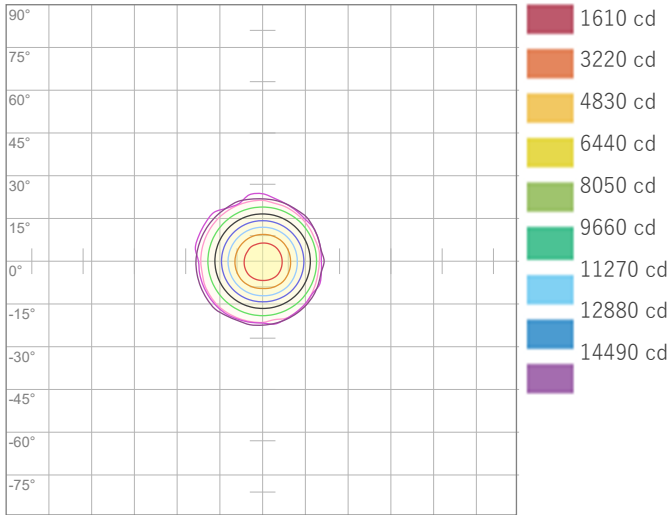

ISO Candela Diagram

Conditions:
Number of c-planes: 8
Candela at center: 16100 cd

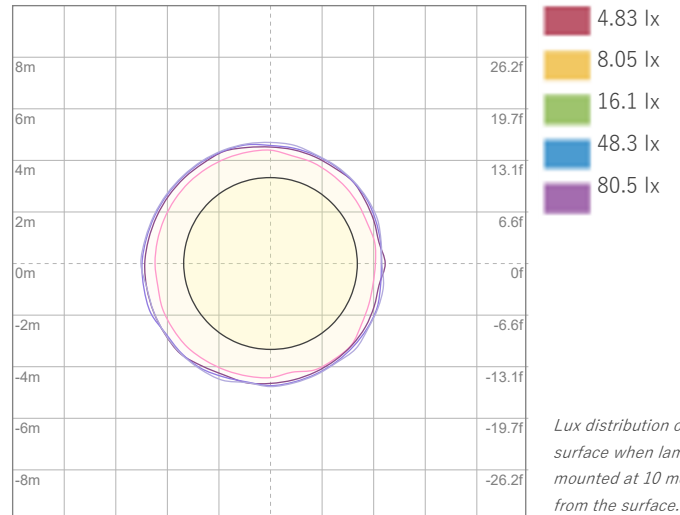

ISO LUX Diagram

Conditions:
Number of c-planes: 8
LUX at center: 161 lx

Lux distribution on a surface when lamp is mounted at 10 meters from the surface.

Linear Distribution

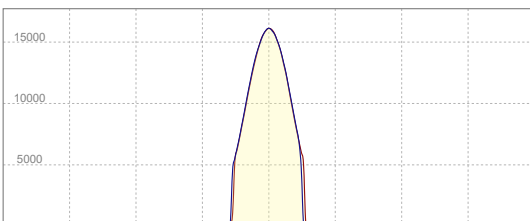

Peak Candela
16110 cd

Calculate Center Beam Intensities

$$\text{lux} = 16110 / \text{distance(m)}^2$$

$$\text{fc} = 16110 / \text{distance(ft)}^2$$

Key Measurements

Output

Total Lumen Output: 5322 lm

Peak Intensity: 16147 cd

Beam

Beam Angle (50%): 36.8°

Field Angle (10%): 50°

Cutoff Angle (2.5%): 52.6°

Color

Color Temperature: 2732 K

CRI: 89.1

TLCI: 93

TM30 R_F: 92.5

TM30 R_g: 106.8

Power Details

Efficacy: 22 Lumen/Watt

Power: 241 W

Supply Voltage: 117 V

Current: 2.06 A

Beam Details

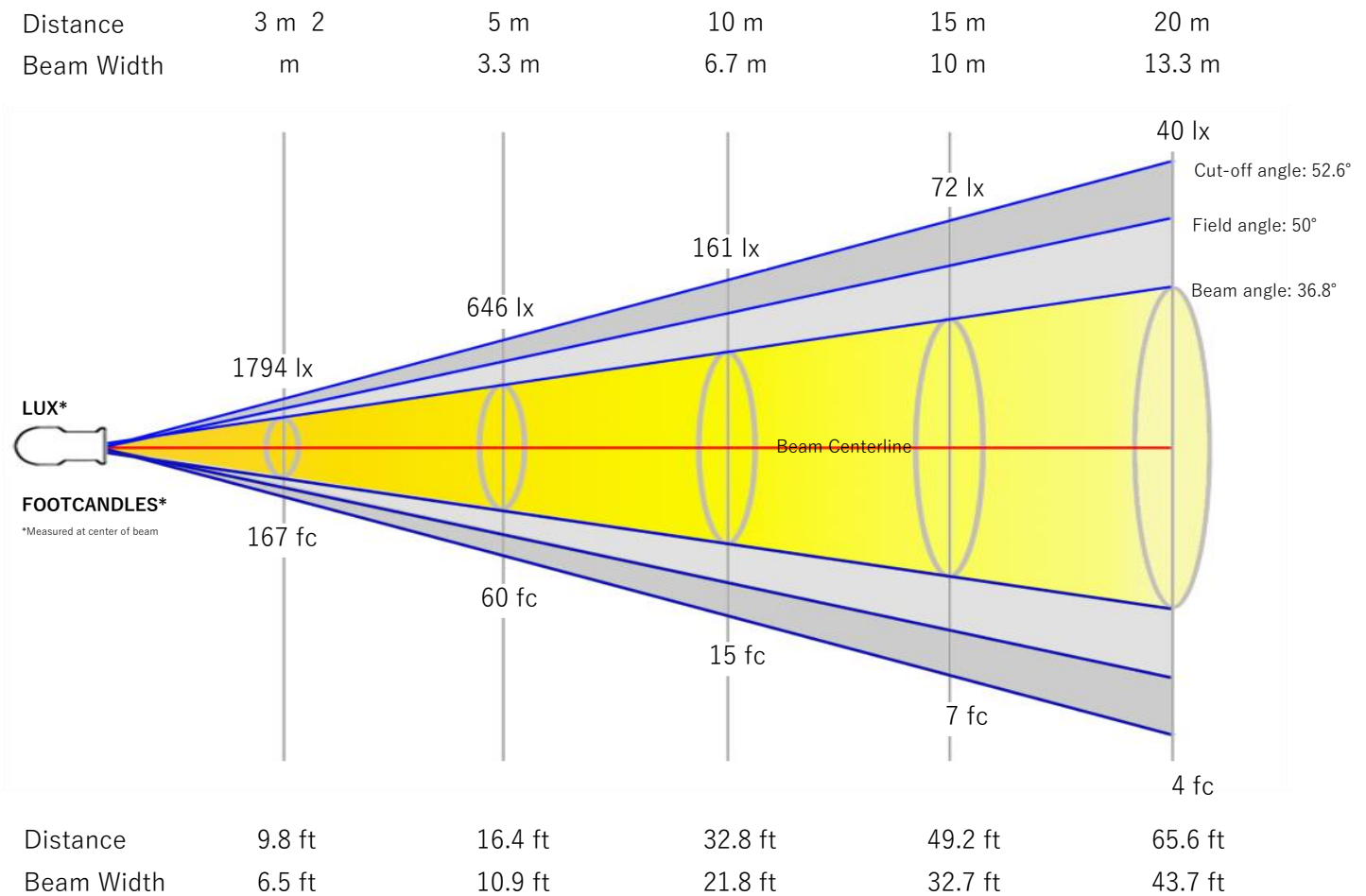

Beam Intensities from 1-20m

M	1	2	3	4	5	6	7	8	9	10	11	12	13	14	15	16	17	18	19	20
LX	16147	4037	1794	1009	646	449	330	252	199	161	133	112	96	82	72	63	56	50	45	40
FT	3.3	6.6	9.8	13.1	16.4	19.7	23	26.2	29.5	32.8	36.1	39.4	42.7	45.9	49.2	52.5	55.8	59.1	62.3	65.6
FC	1500.1	375	166.7	93.8	60	41.7	30.6	23.4	18.5	15	12.4	10.4	8.9	7.7	6.7	5.9	5.2	4.6	4.2	3.8

Angular Distribution

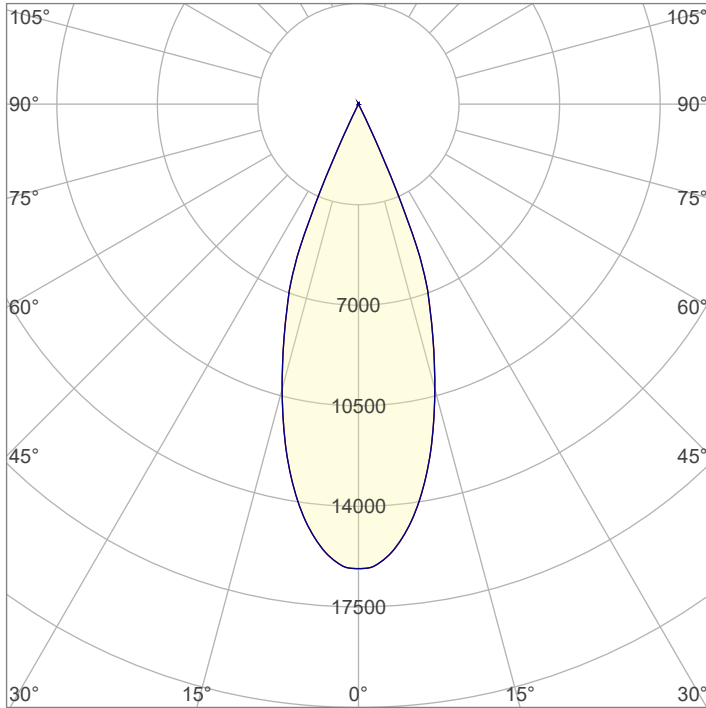

Beam Angle - 50%
36.8°
Field Angle - 10%
50°
Cutoff Angle - 2.5%
52.6°

ISO Diagrams

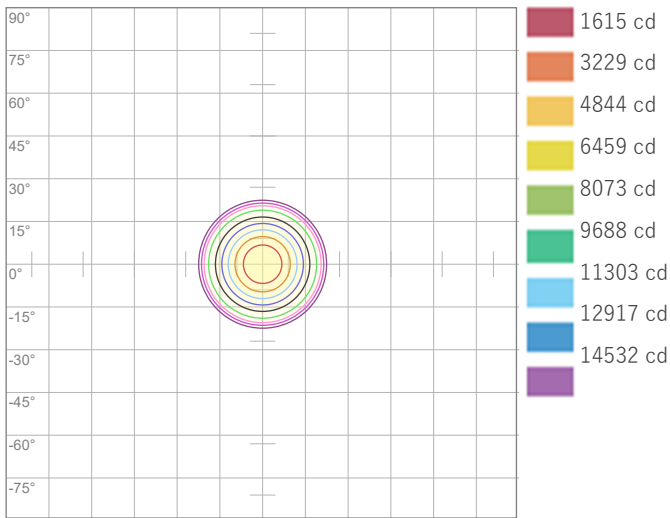

ISO Candela Diagram

Conditions:

Number of c-planes: 8

Candela at center: 16147 cd

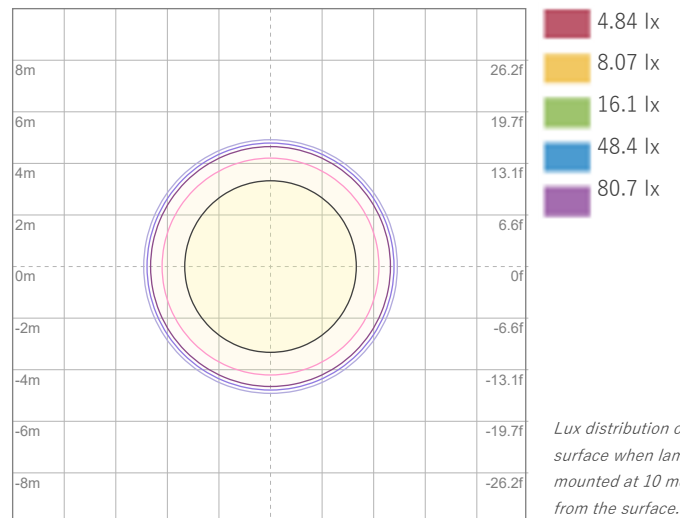

ISO LUX Diagram

Conditions:

Number of c-planes: 8

LUX at center: 161 lx

Lux distribution on a surface when lamp is mounted at 10 meters from the surface.

Linear Distribution

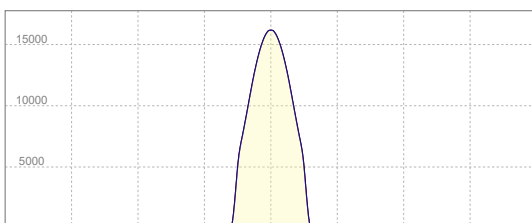

Peak Candela
16147 cd

Calculate Center Beam Intensities

$$\text{lux} = 16147 / \text{distance(m)}^2$$

$$\text{fc} = 16147 / \text{distance(ft)}^2$$

Key Measurements

Output

Total Lumen Output: 5586 lm

Peak Intensity: 17034 cd

Beam

Beam Angle (50%): 36.9°

Field Angle (10%): 49.6°

Cutoff Angle (2.5%): 52.1°

Color

Color Temperature: 3265 K

CRI: 90.9

TLCI: 94

TM30 R_F: 92.1

TM30 R_g: 105.9

Power Details

Efficacy: 23 Lumen/Watt

Power: 245 W

Supply Voltage: 116 V

Current: 2.11 A

Beam Details

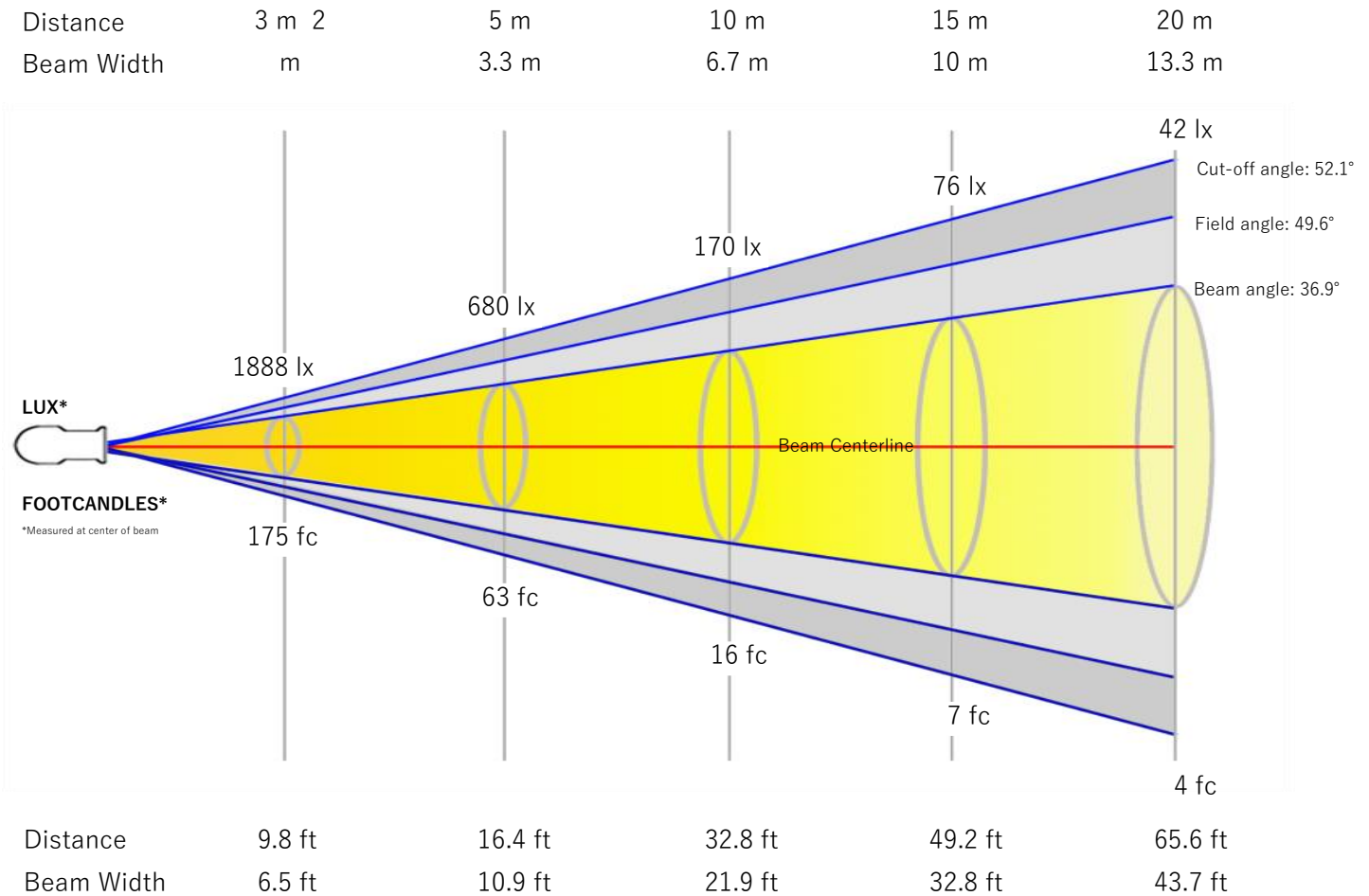

Beam Intensities from 1-20m

M	1	2	3	4	5	6	7	8	9	10	11	12	13	14	15	16	17	18	19	20
LX	16991	4248	1888	1062	680	472	347	265	210	170	140	118	101	87	76	66	59	52	47	42
FT	3.3	6.6	9.8	13.1	16.4	19.7	23	26.2	29.5	32.8	36.1	39.4	42.7	45.9	49.2	52.5	55.8	59.1	62.3	65.6
FC	1578.5	394.6	175.4	98.7	63.1	43.8	32.2	24.7	19.5	15.8	13	11	9.3	8.1	7	6.2	5.5	4.9	4.4	3.9

Angular Distribution

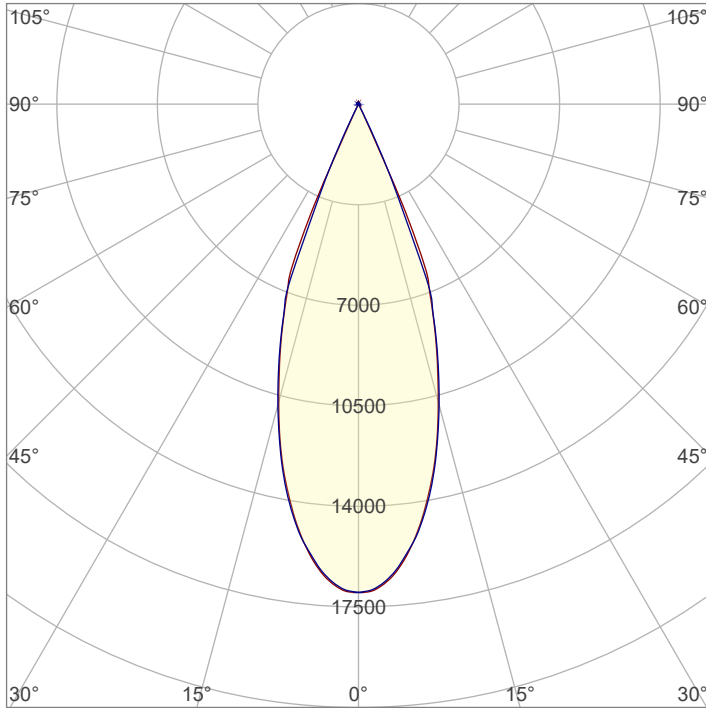

Beam Angle - 50%
36.9°
Field Angle - 10%
49.6°
Cutoff Angle - 2.5%
52.1°

ISO Diagrams

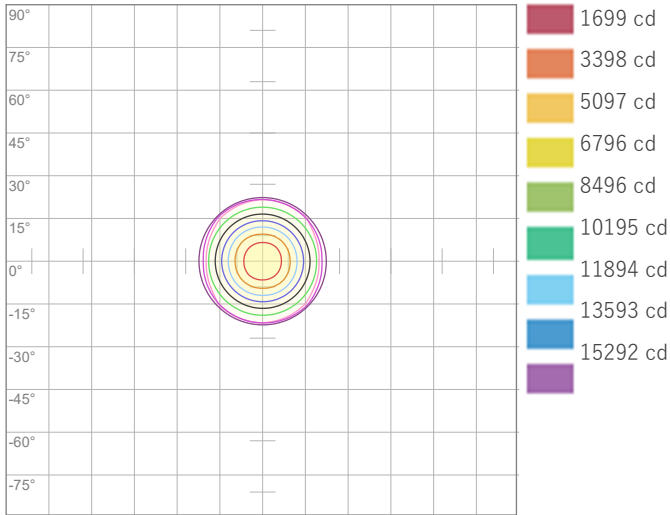

ISO Candela Diagram

Conditions:

Number of c-planes: 8

Candela at center: 16991 cd

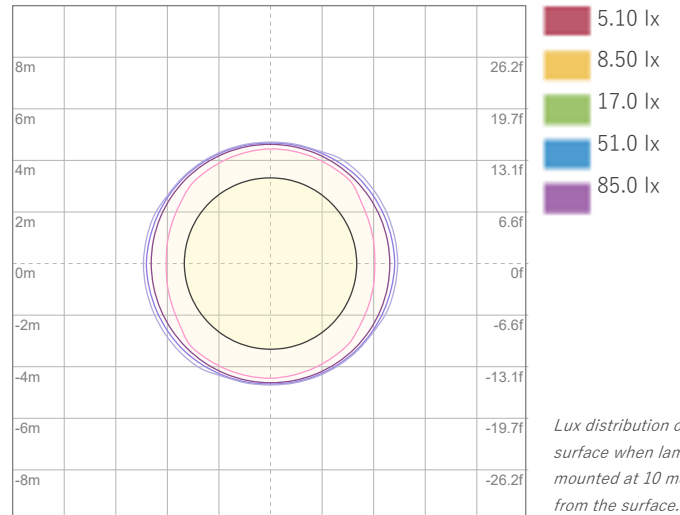

ISO LUX Diagram

Conditions:

Number of c-planes: 8

LUX at center: 170 lx

Lux distribution on a surface when lamp is mounted at 10 meters from the surface.

Linear Distribution

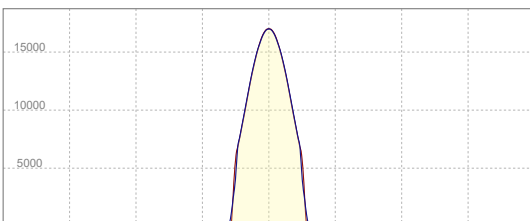

Peak Candela
17034 cd

Calculate Center Beam Intensities

$$\text{lux} = 17034 / \text{distance(m)}^2$$

$$\text{fc} = 17034 / \text{distance(ft)}^2$$

Key Measurements

Output

Total Lumen Output: 5336 lm

Peak Intensity: 15974 cd

Beam

Beam Angle (50%): 37.1°

Field Angle (10%): 49.5°

Cutoff Angle (2.5%): 52°

Color

Color Temperature: 5672 K

CRI: 90.4

TLCI: 93

TM30 R_F: 89.6

TM30 R_g: 106.3

Power Details

Efficacy: 22 Lumen/Watt

Power: 240 W

Supply Voltage: 117 V

Current: 2.05 A

Beam Details

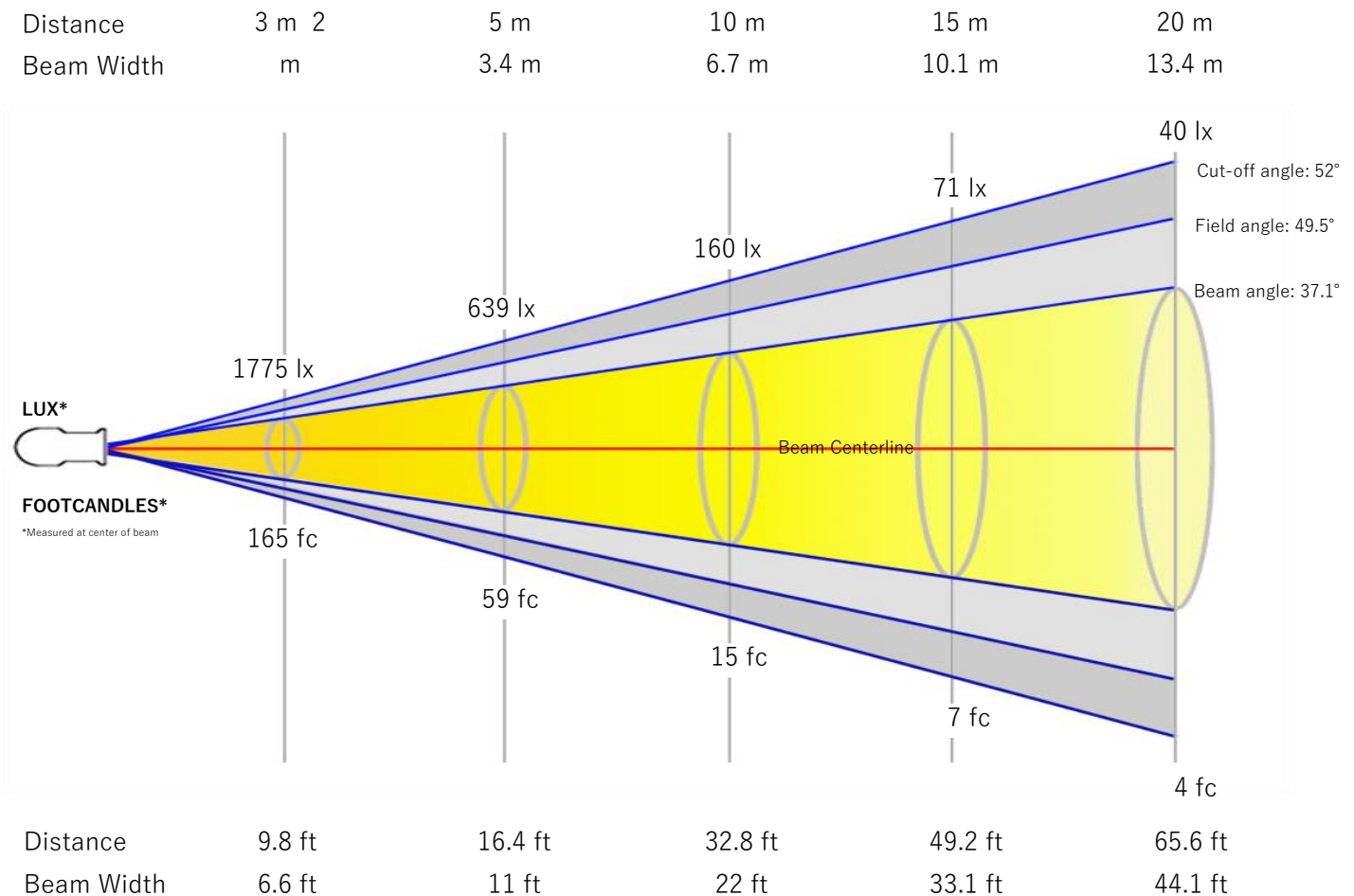

Beam Intensities from 1-20m

M	1	2	3	4	5	6	7	8	9	10	11	12	13	14	15	16	17	18	19	20
LX	15974	3994	1775	998	639	444	326	250	197	160	132	111	95	82	71	62	55	49	44	40
FT	3.3	6.6	9.8	13.1	16.4	19.7	23	26.2	29.5	32.8	36.1	39.4	42.7	45.9	49.2	52.5	55.8	59.1	62.3	65.6
FC	1484.1	371	164.9	92.8	59.4	41.2	30.3	23.2	18.3	14.8	12.3	10.3	8.8	7.6	6.6	5.8	5.1	4.6	4.1	3.7

Angular Distribution

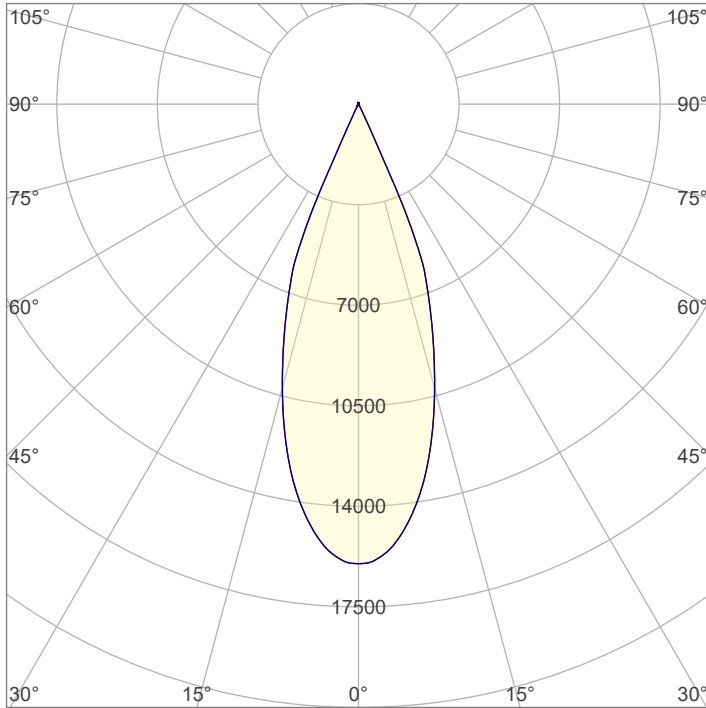

Beam Angle - 50%
37.1°
Field Angle - 10%
49.5°
Cutoff Angle - 2.5%
52°

ISO Diagrams

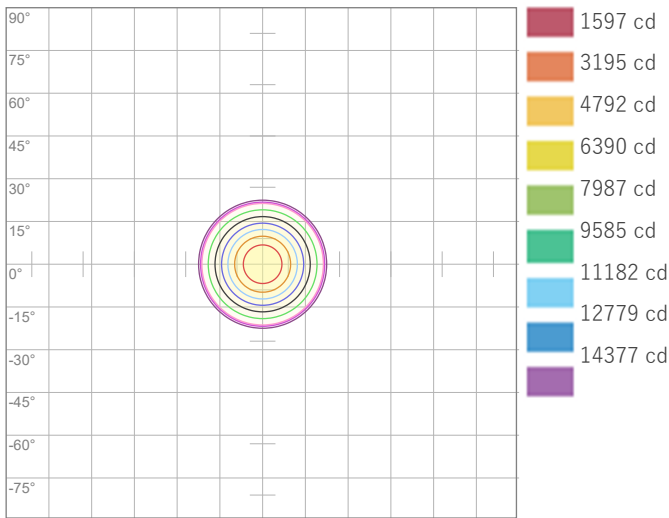

ISO Candela Diagram

Conditions:
Number of c-planes: 8
Candela at center: 15974 cd

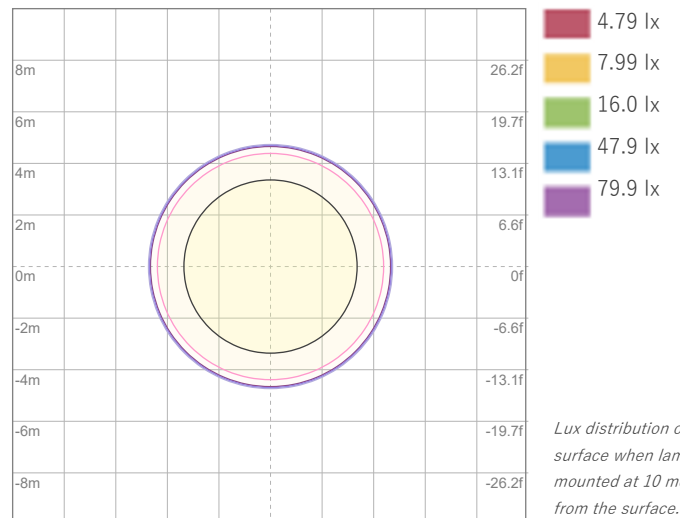

ISO LUX Diagram

Conditions:
Number of c-planes: 8
LUX at center: 160 lx

Lux distribution on a surface when lamp is mounted at 10 meters from the surface.

Linear Distribution

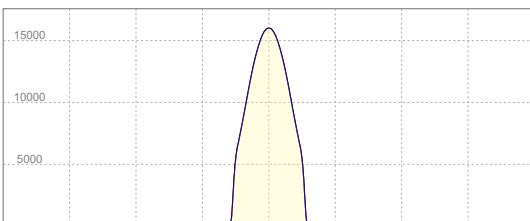

Peak Candela
15974 cd

Calculate Center Beam Intensities

$$\text{lux} = 15974 / \text{distance(m)}^2$$

$$\text{fc} = 15974 / \text{distance(ft)}^2$$

Key Measurements

Output

Total Lumen Output: 5335 lm

Peak Intensity: 16002 cd

Beam

Beam Angle (50%): 37°

Field Angle (10%): 50°

Cutoff Angle (2.5%): 52.4°

Color

Color Temperature: 6514 K

CRI: 92.1

TLCI: 93

TM30 R_F: 88.7

TM30 R_g: 103.2

Power Details

Efficacy: 22 Lumen/Watt

Power: 240 W

Supply Voltage: 117 V

Current: 2.05 A

Beam Details

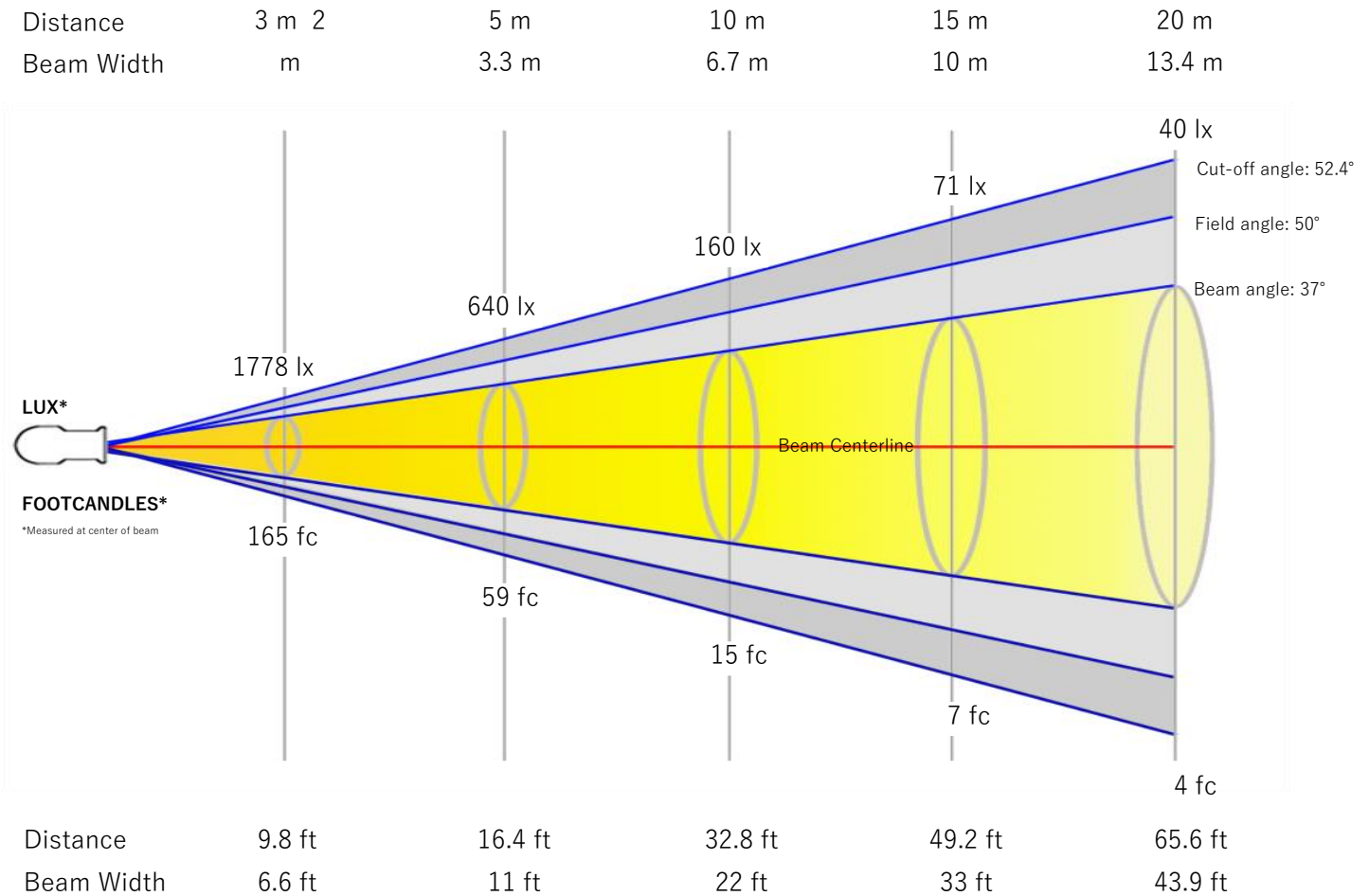

Beam Intensities from 1-20m

M	1	2	3	4	5	6	7	8	9	10	11	12	13	14	15	16	17	18	19	20
LX	16002	4000	1778	1000	640	444	327	250	198	160	132	111	95	82	71	63	55	49	44	40
FT	3.3	6.6	9.8	13.1	16.4	19.7	23	26.2	29.5	32.8	36.1	39.4	42.7	45.9	49.2	52.5	55.8	59.1	62.3	65.6
FC	1486.6	371.6	165.2	92.9	59.5	41.3	30.3	23.2	18.4	14.9	12.3	10.3	8.8	7.6	6.6	5.8	5.1	4.6	4.1	3.7

Angular Distribution

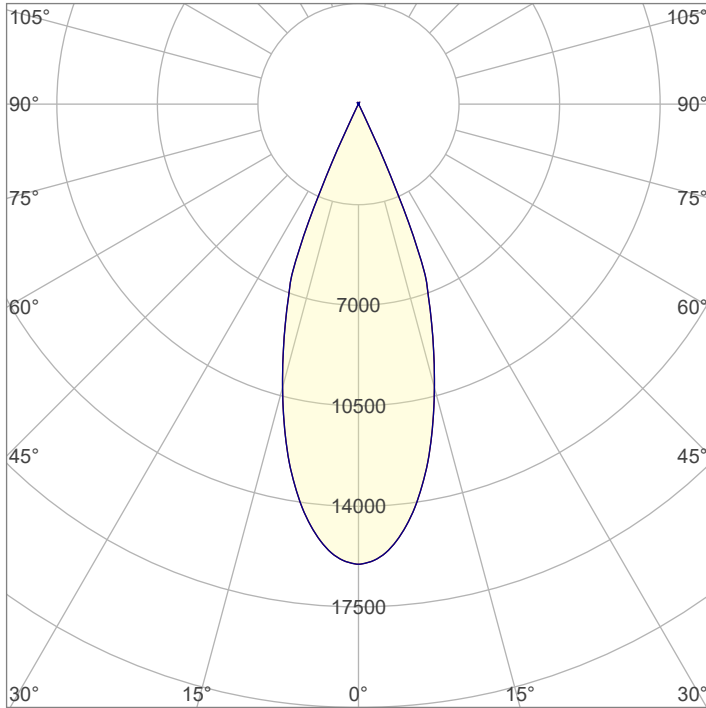

Beam Angle - 50%
37°
Field Angle - 10%
50°
Cutoff Angle - 2.5%
52.4°

ISO Diagrams

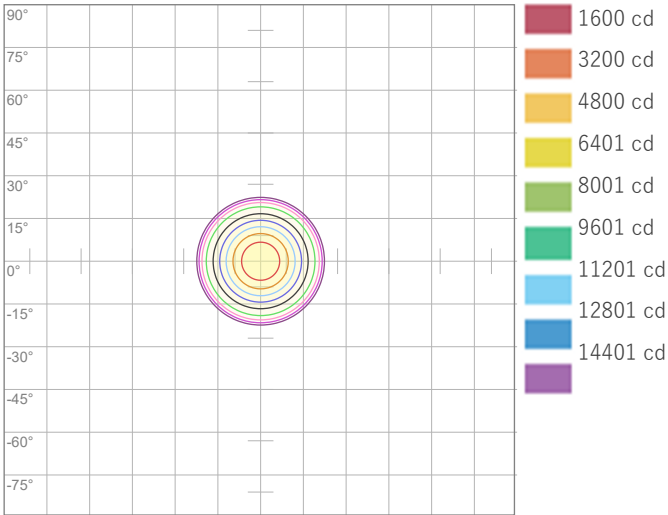

ISO Candela Diagram

Conditions:

Number of c-planes: 8

Candela at center: 16002 cd

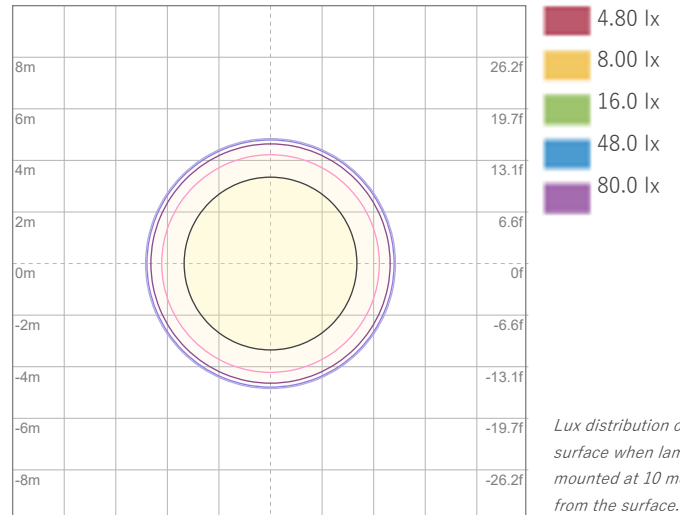

ISO LUX Diagram

Conditions:

Number of c-planes: 8

LUX at center: 160 lx

Lux distribution on a surface when lamp is mounted at 10 meters from the surface.

Linear Distribution

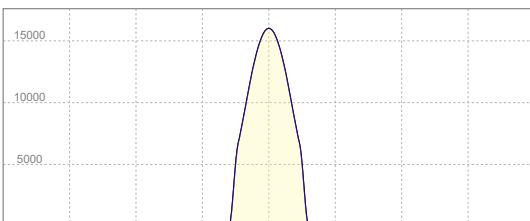

Peak Candela
16002 cd

Calculate Center Beam Intensities

$$\text{lux} = 16002 / \text{distance(m)}^2$$

$$\text{fc} = 16002 / \text{distance(ft)}^2$$

Key Measurements

Output

Total Lumen Output: 5820 lm

Peak Intensity: 17478 cd

Beam

Beam Angle (50%): 37°

Field Angle (10%): 49.8°

Cutoff Angle (2.5%): 52.5°

Color

Color Temperature: 8198 K

CRI: 83.7

TLCI: 70

TM30 R_F: 80.6

TM30 R_g: 95.0

Power Details

Efficacy: 24 Lumen/Watt

Power: 247 W

Supply Voltage: 116 V

Current: 2.13 A

Beam Details

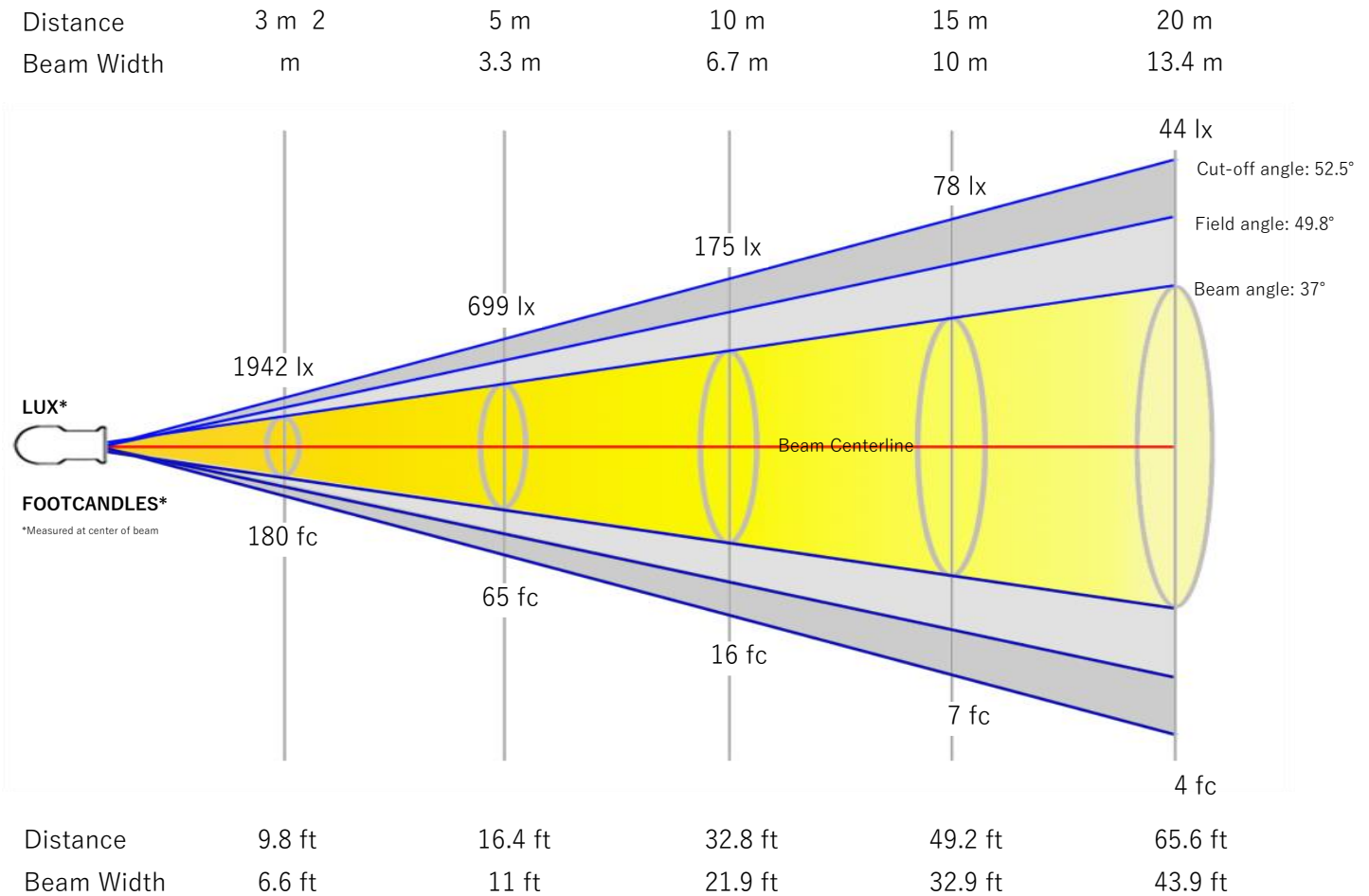

Beam Intensities from 1-20m

M	1	2	3	4	5	6	7	8	9	10	11	12	13	14	15	16	17	18	19	20
LX	17478	4370	1942	1092	699	486	357	273	216	175	144	121	103	89	78	68	60	54	48	44
FT	3.3	6.6	9.8	13.1	16.4	19.7	23	26.2	29.5	32.8	36.1	39.4	42.7	45.9	49.2	52.5	55.8	59.1	62.3	65.6
FC	1623.8	405.9	180.4	101.5	65	45.1	33.1	25.4	20	16.2	13.4	11.3	9.6	8.3	7.2	6.3	5.6	5	4.5	4.1

Angular Distribution

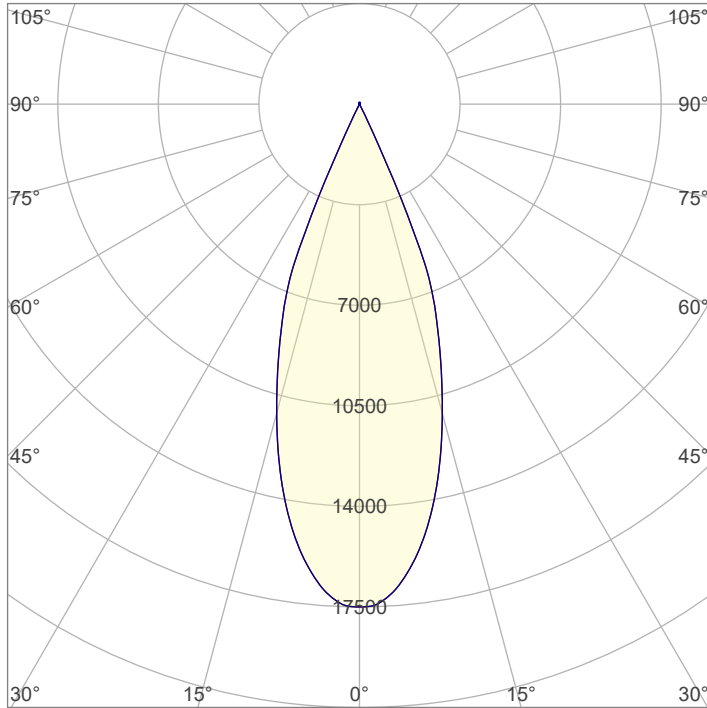

Beam Angle - 50%
37°
Field Angle - 10%
49.8°
Cutoff Angle - 2.5%
52.5°

ISO Diagrams

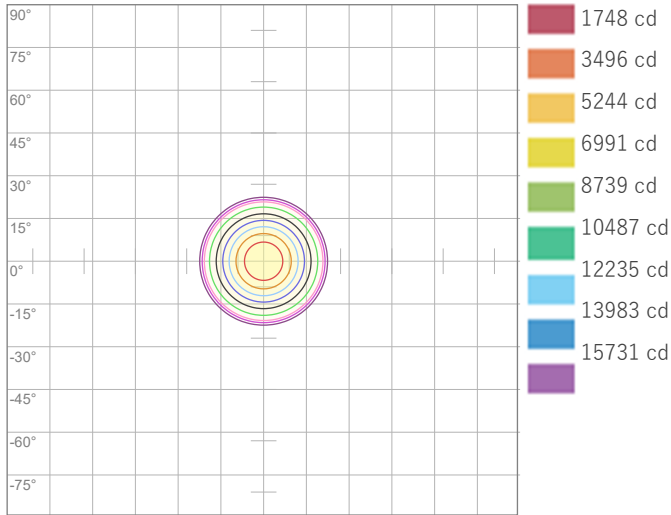

ISO Candela Diagram

Conditions:

Number of c-planes: 8

Candela at center: 17478 cd

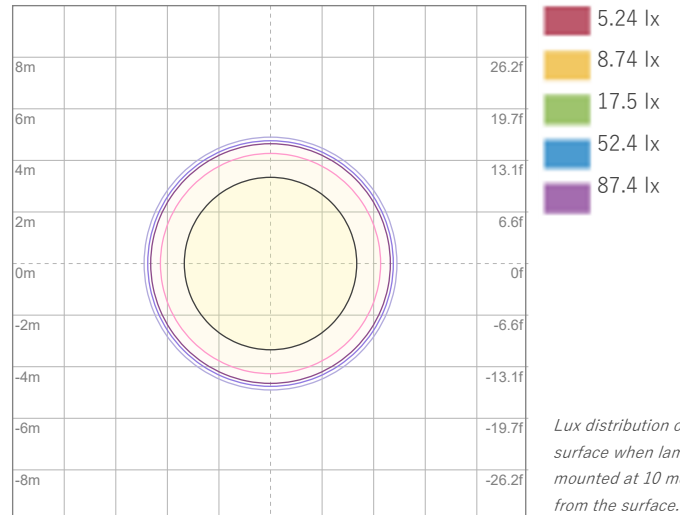

ISO LUX Diagram

Conditions:

Number of c-planes: 8

LUX at center: 175 lx

Lux distribution on a surface when lamp is mounted at 10 meters from the surface.

Linear Distribution

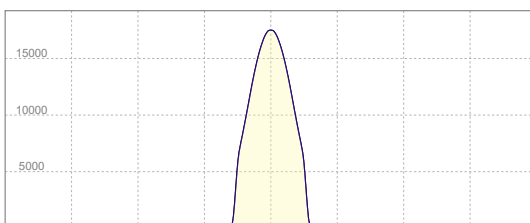

Peak Candela
17478 cd

Calculate Center Beam Intensities

$$\text{lux} = 17478 / \text{distance(m)}^2$$

$$\text{fc} = 17478 / \text{distance(ft)}^2$$

Color Temperature: 6076K

Accuracy Metric Overview

Color Rendering Index	Color Rendering Index, R9 (Red Component)	TM-30 Color Fidelity	TM-30 Color Gamut	Television Lighting Consistency Index	Color Quality Scale	Color Coordinate- CIE 1931	Color Coordinate- CIE 1931	Deviation from Black Body	SSI [CIE A] Tungsten	SSI [CIE D65] Daylight
CRI	CRI R9	TM30 R _f	TM30 R _g	TLCI	CQS	x	Y	Δuv	SSIt	SSId
91.1	65.8	89.3	105.7	94	91.5	0.321	0.330	-0.0005	31	56

CIE 1931

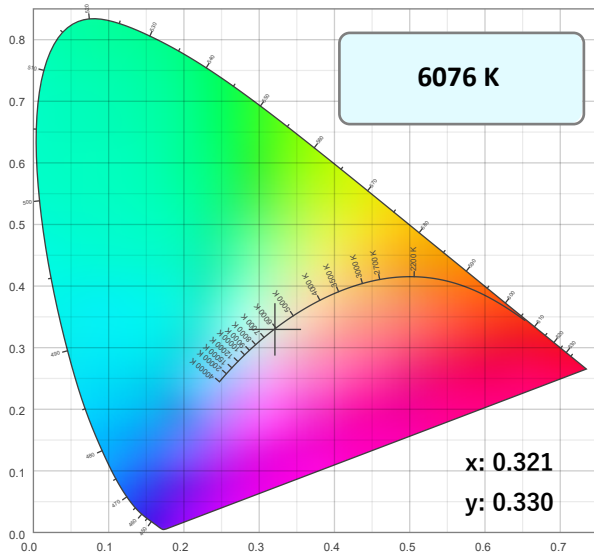

CIE 1931 ZOOMED

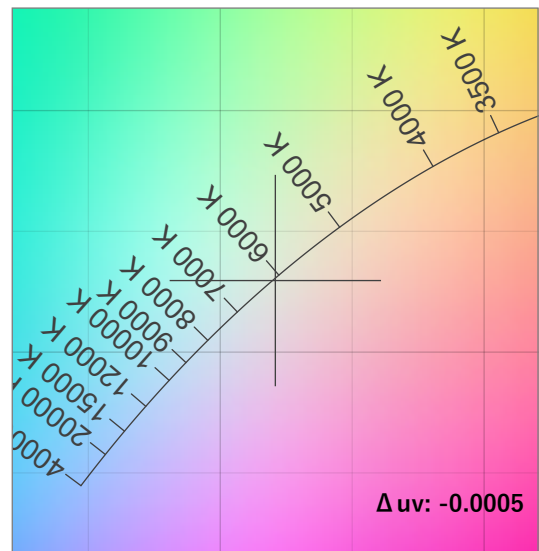

CRI: 91.1 (R1-R8)

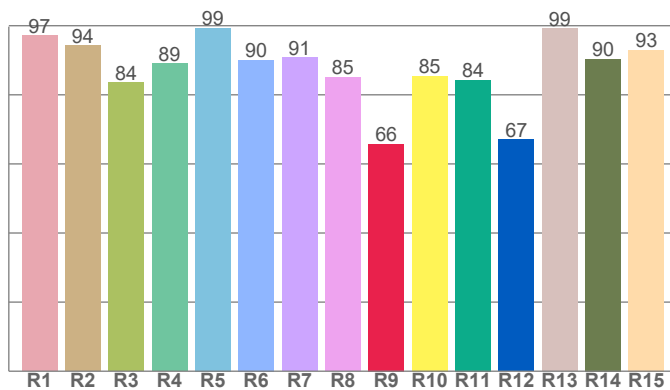

Spectral Power Distribution (SPD)

Dominant Wavelength 604 nm

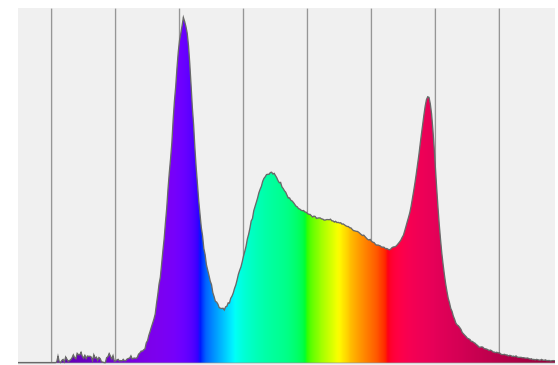

SSI Spectral Variance Graph- Tungsten

SSI [CIE A] 31

Spectral variance

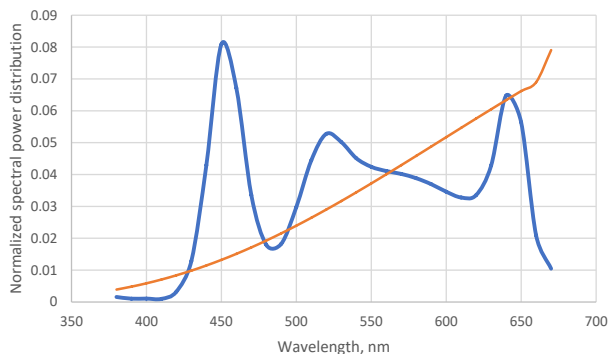

— Test Source — CIE Illuminant A - Tungsten

SSI Spectral Variance Graph- Daylight

SSI [CIE D65] 56

Spectral variance

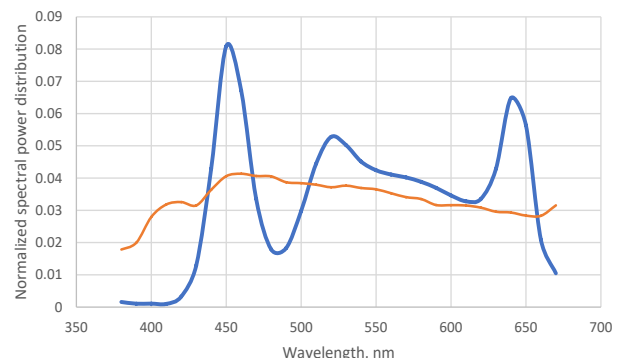

— Test Source — CIE Illuminant D65 - Daylight

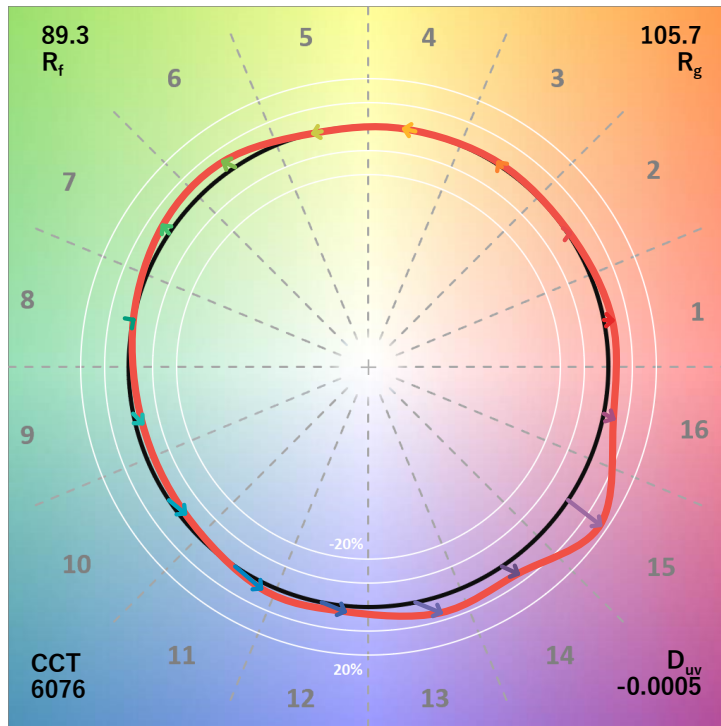

TM30-18 R_f Values per Hue Bin

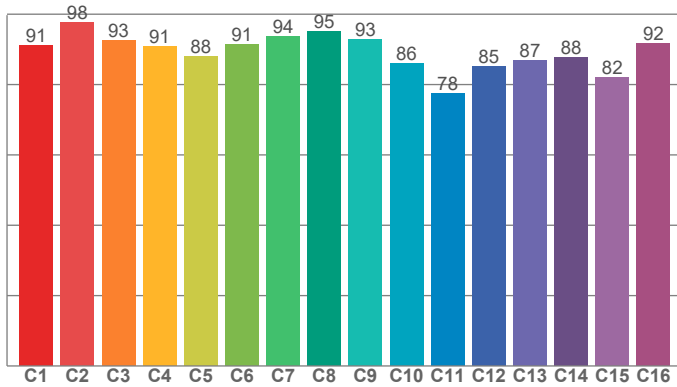

TM30 Chroma Shift per Hue Bin

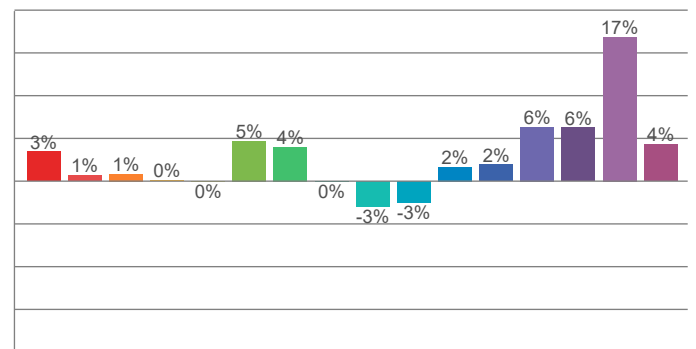

TM30-18 R_f Values per Reference Color (CES)

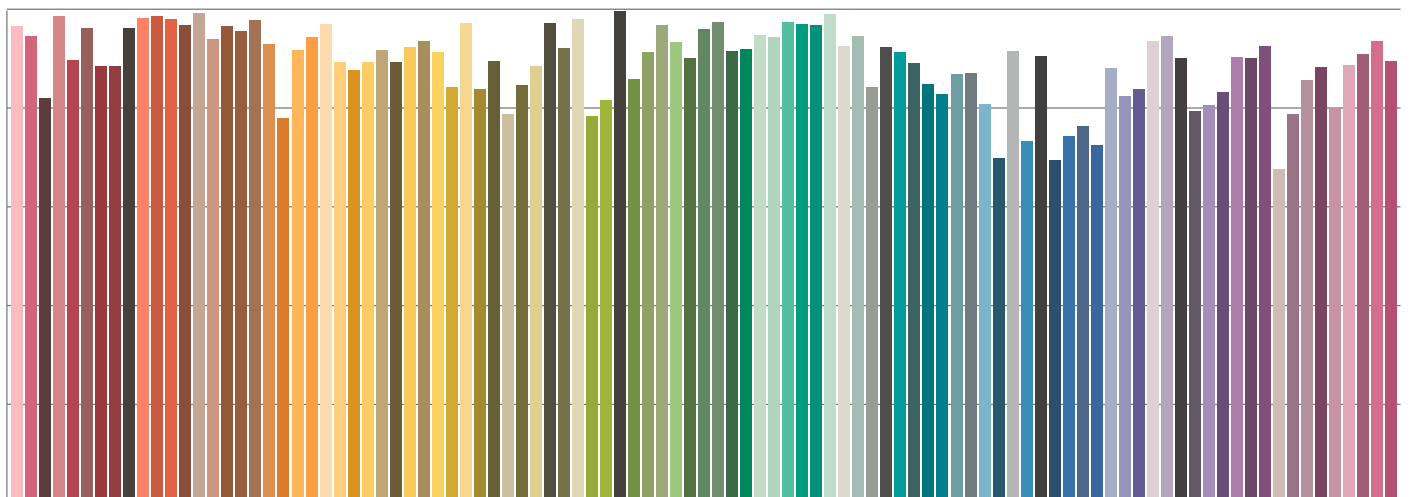

Color Temperature: 2713K

Accuracy Metric Overview

Color Rendering Index	Color Rendering Index, R9 (Red Component)	TM-30 Color Fidelity	TM-30 Color Gamut	Television Lighting Consistency Index	Color Quality Scale	Color Coordinate- CIE 1931	Color Coordinate- CIE 1931	Deviation from Black Body	SSI [CIE A] Tungsten	SSI [CIE D65] Daylight
CRI	CRI R9	TM30 R _f	TM30 R _g	TLCI	CQS	x	Y	Δuv	SSIt	SSId
89.0	47.6	92.4	107.0	93	91.9	0.460	0.412	0.0003	65	10

CIE 1931

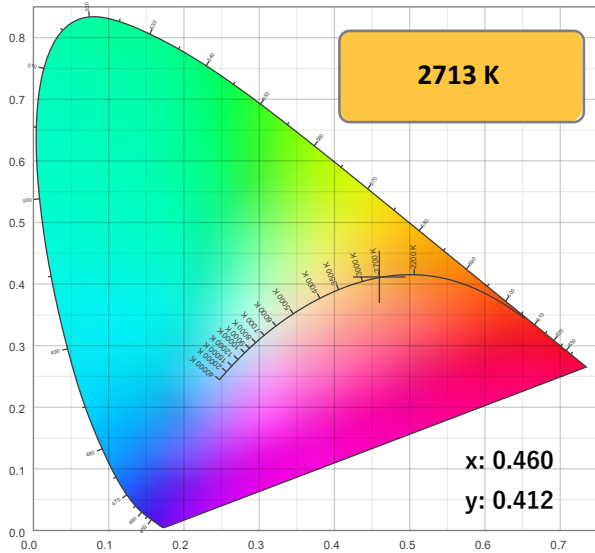

CIE 1931 ZOOMED

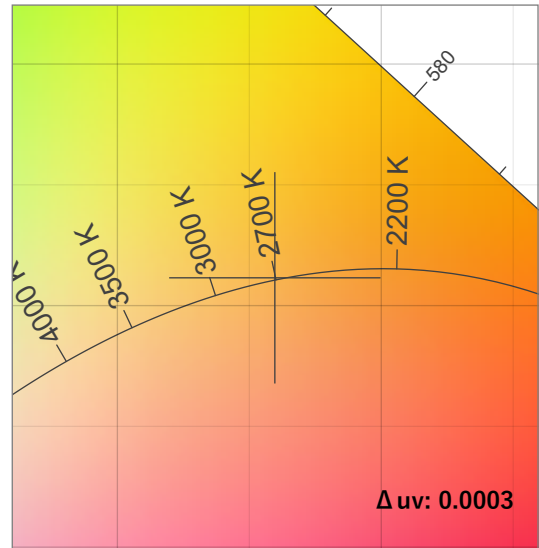

CRI: 89.0 (R1-R8)

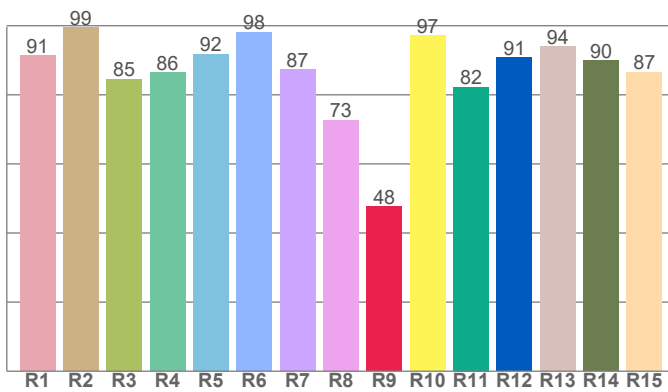

Spectral Power Distribution (SPD)

Dominant Wavelength 585 nm

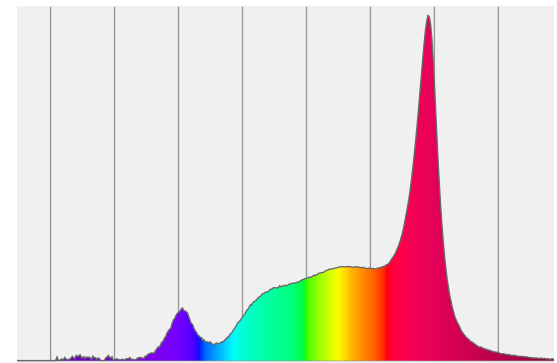

SSI Spectral Variance Graph- Tungsten

SSI [CIE A] 65

Spectral variance

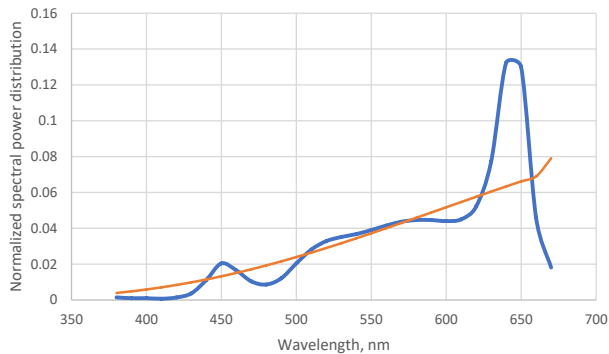

— Test Source — CIE Illuminant A - Tungsten

SSI Spectral Variance Graph- Daylight

SSI [CIE D65] 10

Spectral variance

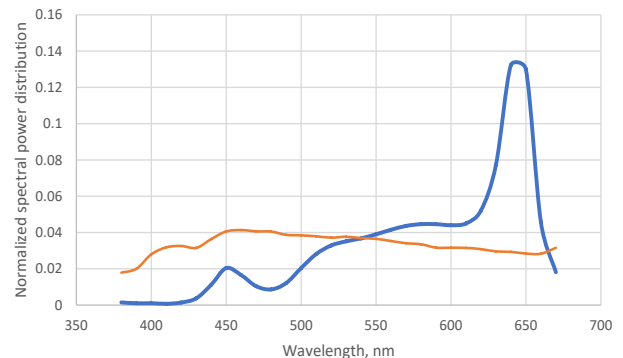

— Test Source — CIE Illuminant D65 - Daylight

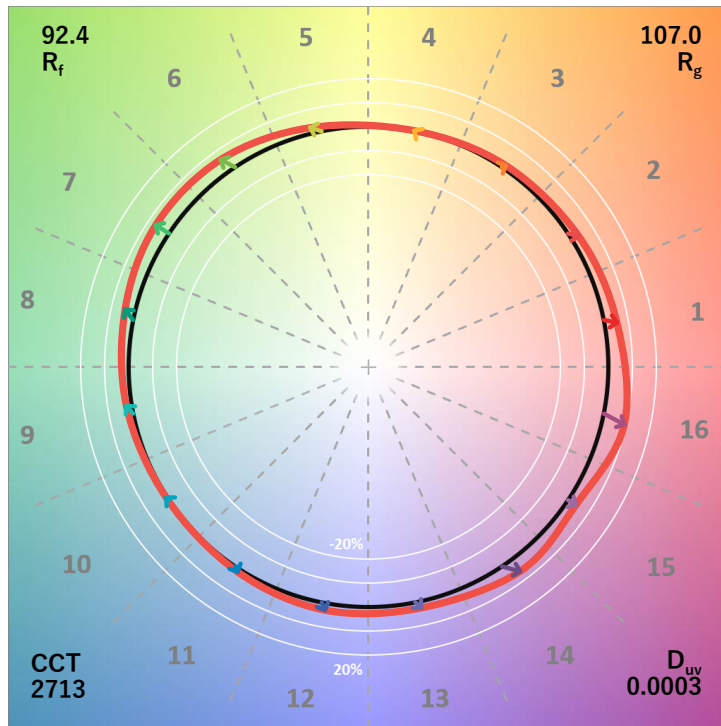

TM30-18 R_f Values per Hue Bin

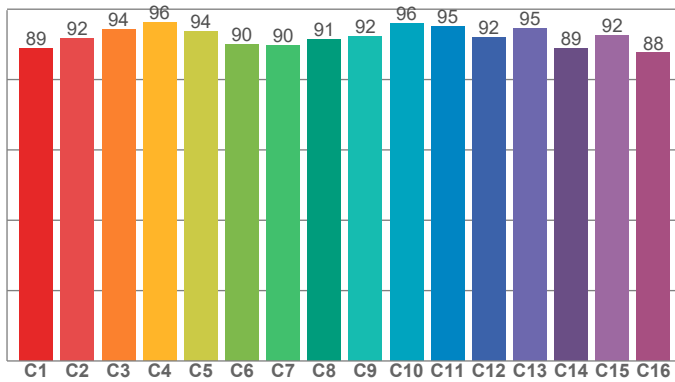

TM30 Chroma Shift per Hue Bin

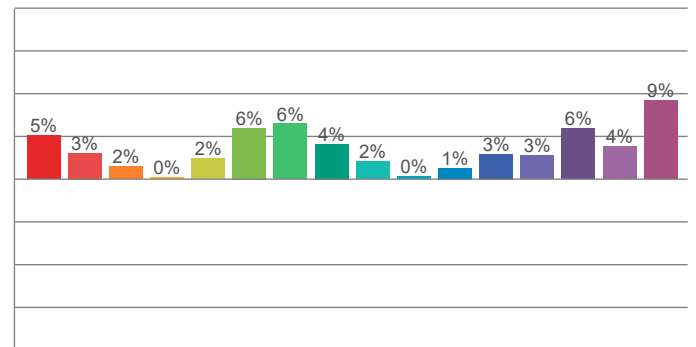

TM30-18 R_f Values per Reference Color (CES)

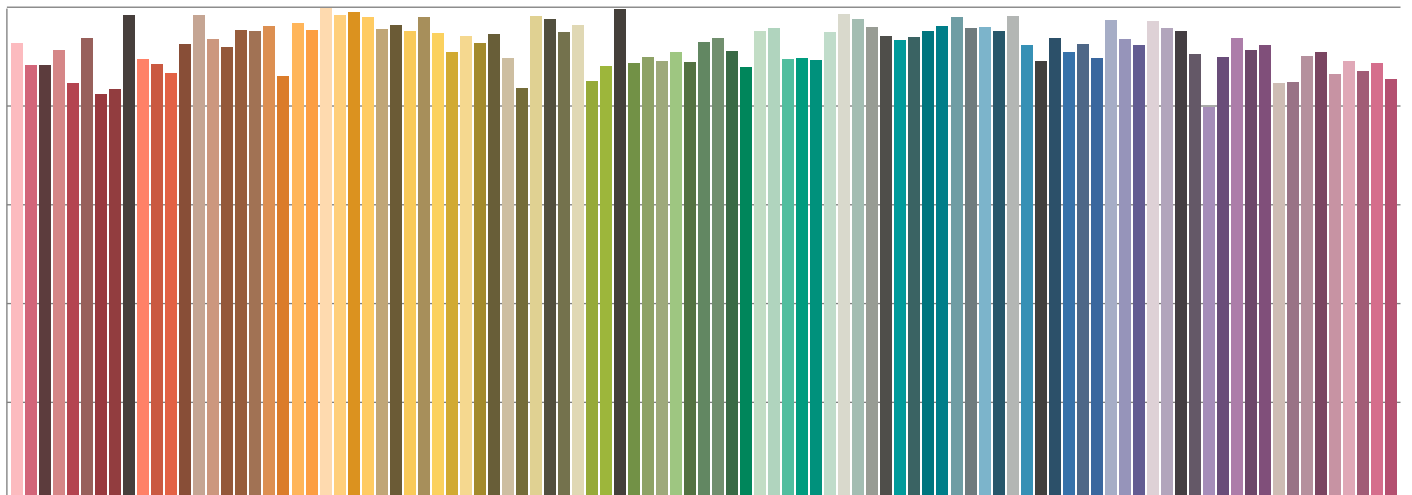

Color Temperature: 3242K

Accuracy Metric Overview

Color Rendering Index	Color Rendering Index, R9 (Red Component)	TM-30 Color Fidelity	TM-30 Color Gamut	Television Lighting Consistency Index	Color Quality Scale	Color Coordinate- CIE 1931	Color Coordinate- CIE 1931	Deviation from Black Body	SSI [CIE A] Tungsten	SSI [CIE D65] Daylight
CRI	CRI R9	TM30 R _f	TM30 R _g	TLCI	CQS	x	Y	Δuv	SSIt	SSId
90.7	57.9	92.0	106.1	94	93.1	0.422	0.399	0.0005	69	27

CIE 1931

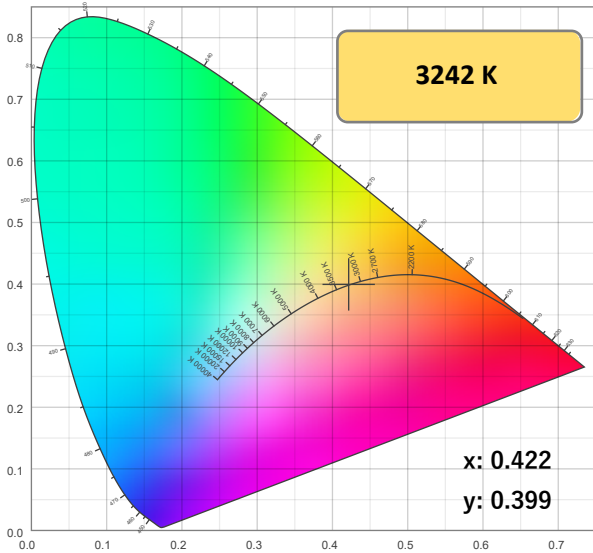

CIE 1931 ZOOMED

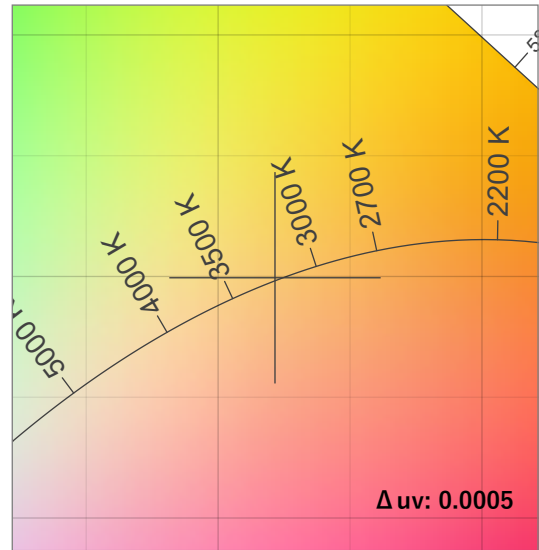

CRI: 90.7 (R1-R8)

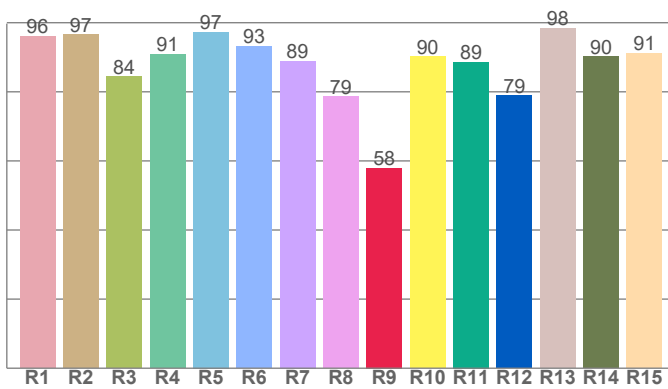

Spectral Power Distribution (SPD)

Dominant Wavelength 583 nm

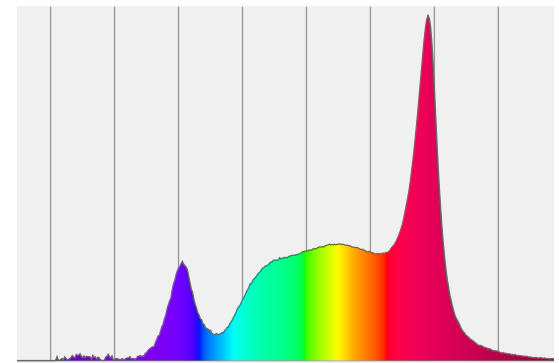

SSI Spectral Variance Graph- Tungsten

SSI [CIE A] 69

Spectral variance

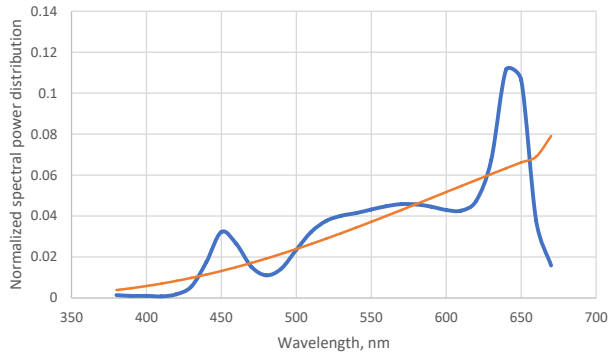

— Test Source — CIE Illuminant A - Tungsten

SSI Spectral Variance Graph- Daylight

SSI [CIE D65] 27

Spectral variance

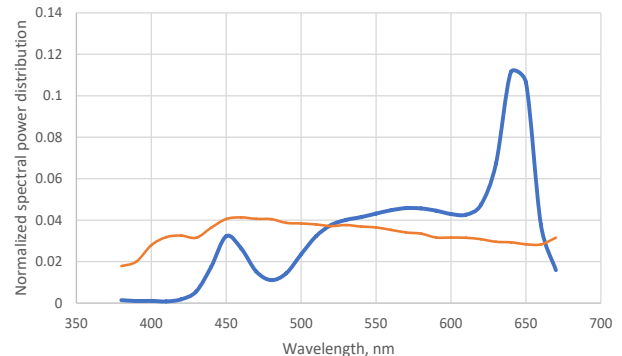

— Test Source — CIE Illuminant D65 - Daylight

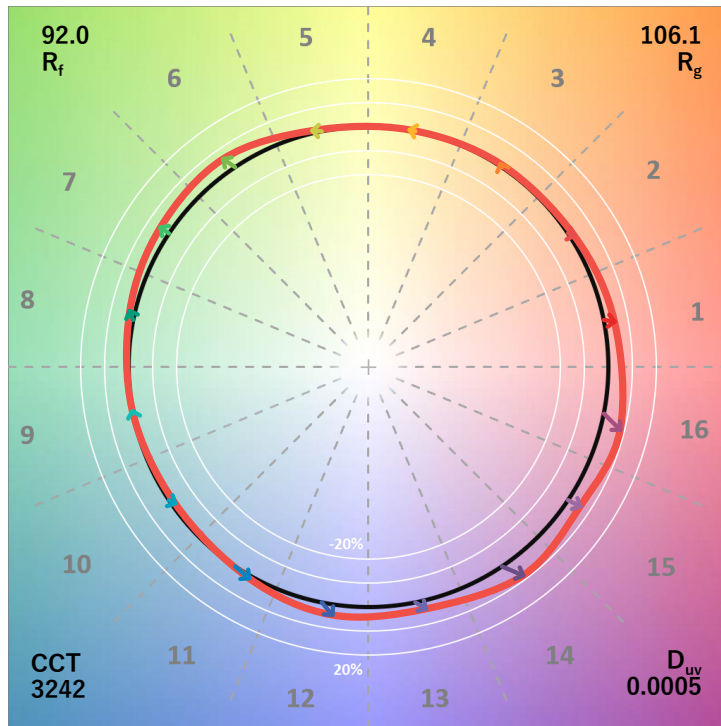

TM30-18 R_f Values per Hue Bin

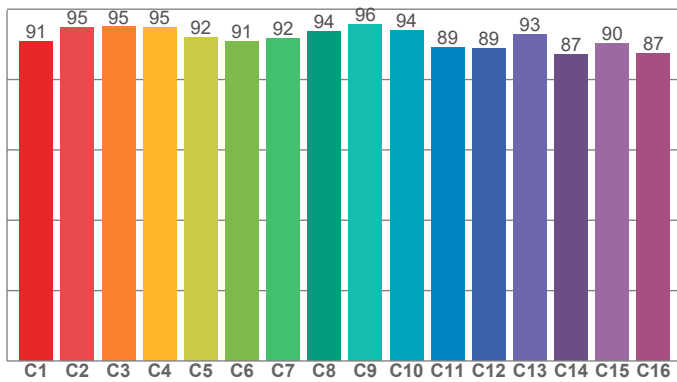

TM30 Chroma Shift per Hue Bin

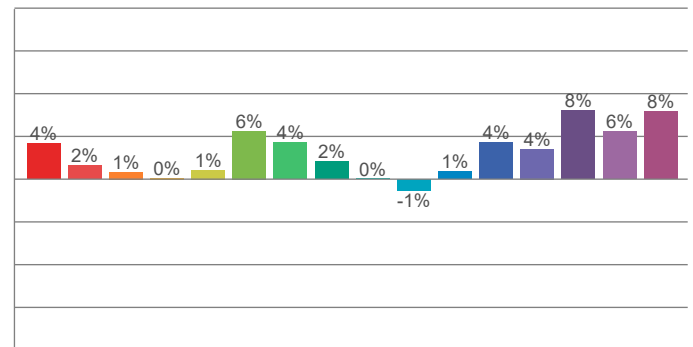

TM30-18 R_f Values per Reference Color (CES)

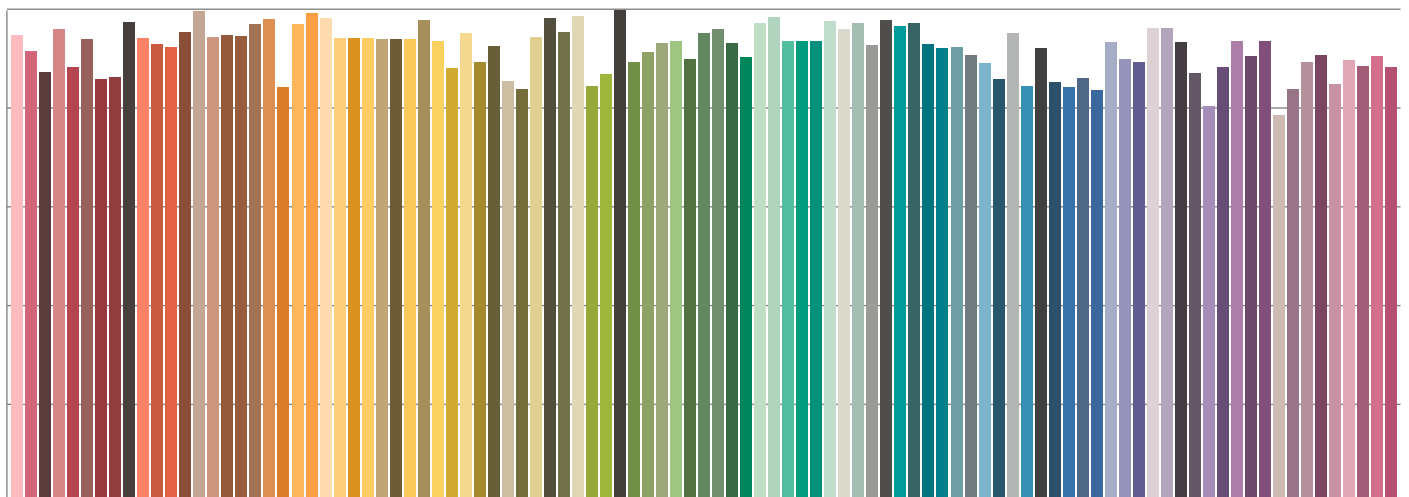

Color Temperature: 5660K

Accuracy Metric Overview

Color Rendering Index	Color Rendering Index, R9 (Red Component)	TM-30 Color Fidelity	TM-30 Color Gamut	Television Lighting Consistency Index	Color Quality Scale	Color Coordinate- CIE 1931	Color Coordinate- CIE 1931	Deviation from Black Body	SSI [CIE A] Tungsten	SSI [CIE D65] Daylight
CRI	CRI R9	TM30 R _f	TM30 R _g	TLCI	CQS	x	Y	Δuv	SSIt	SSId
90.1	56.2	89.4	106.6	93	92.1	0.329	0.337	-0.0005	36	54

CIE 1931

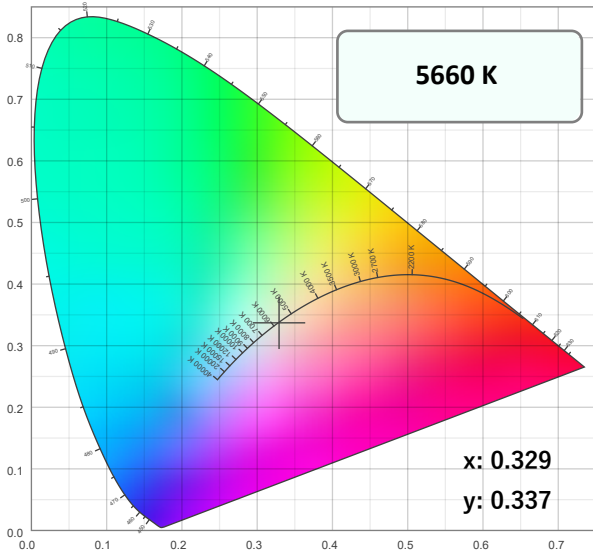

CIE 1931 ZOOMED

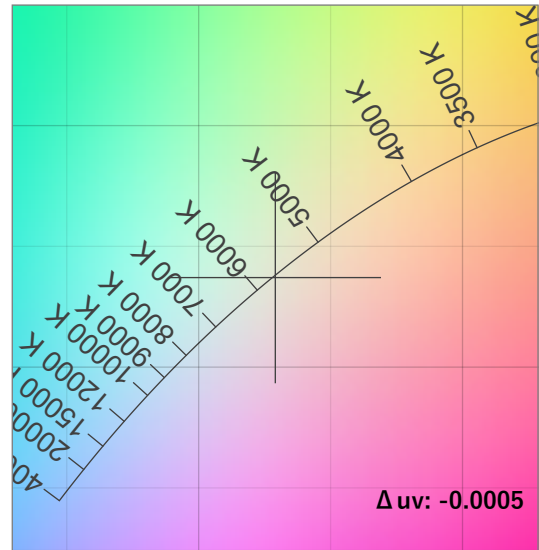

CRI: 90.1 (R1-R8)

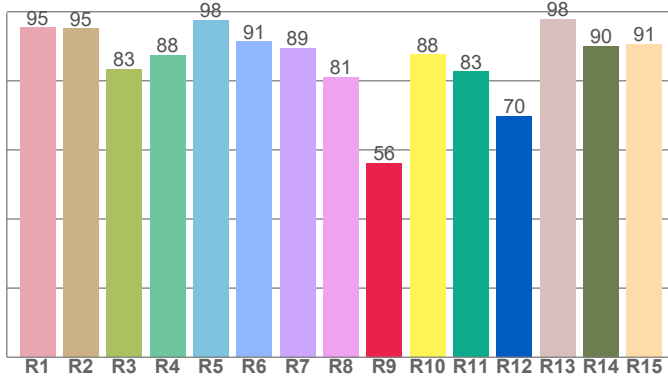

Spectral Power Distribution (SPD)

Dominant Wavelength 586 nm

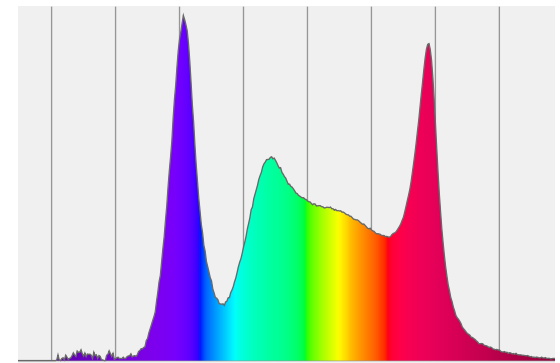

SSI Spectral Variance Graph- Tungsten

SSI [CIE A] 36

Spectral variance

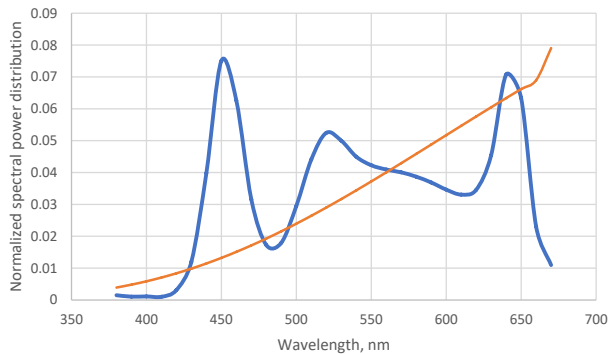

— Test Source — CIE Illuminant A - Tungsten

SSI Spectral Variance Graph- Daylight

SSI [CIE D65] 54

Spectral variance

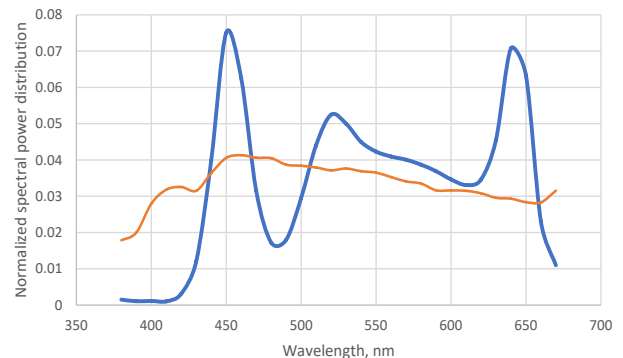

— Test Source — CIE Illuminant D65 - Daylight

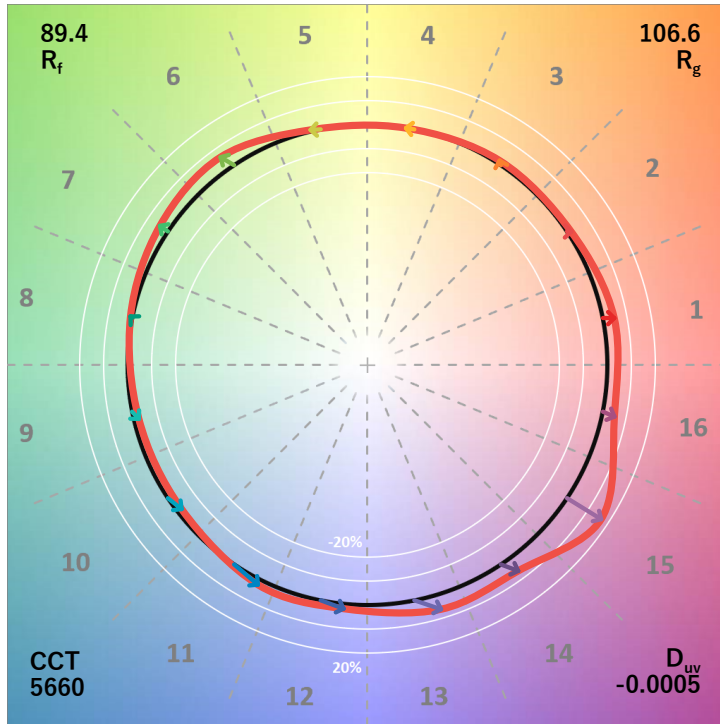

TM30-18 R_f Values per Hue Bin

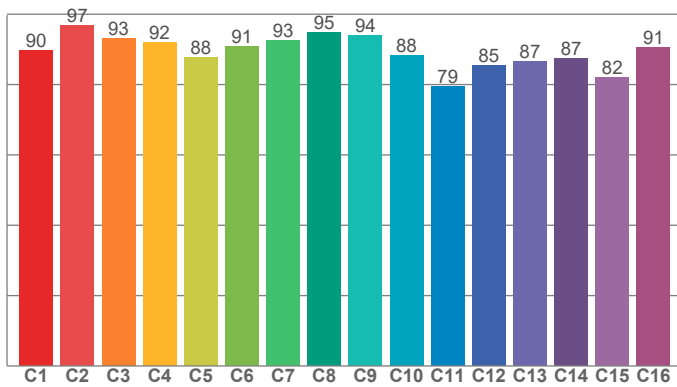

TM30 Chroma Shift per Hue Bin

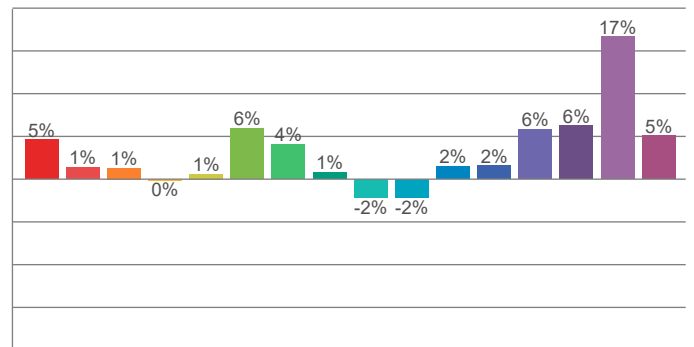

TM30-18 R_f Values per Reference Color (CES)

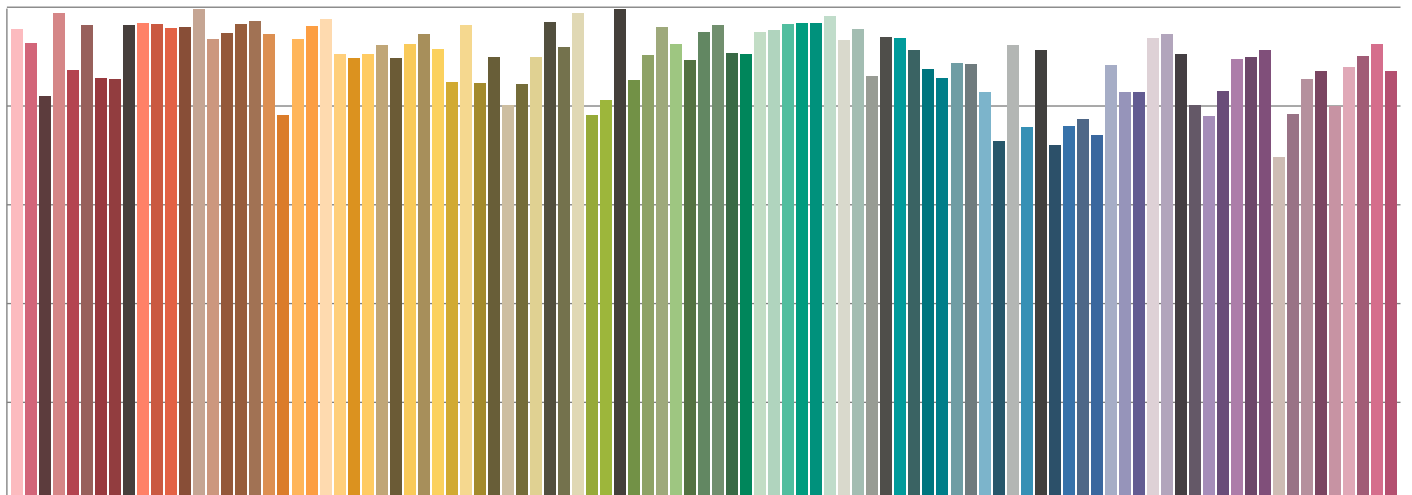

Color Temperature: 6550K

Accuracy Metric Overview

Color Rendering Index	Color Rendering Index, R9 (Red Component)	TM-30 Color Fidelity	TM-30 Color Gamut	Television Lighting Consistency Index	Color Quality Scale	Color Coordinate- CIE 1931	Color Coordinate- CIE 1931	Deviation from Black Body	SSI [CIE A] Tungsten	SSI [CIE D65] Daylight
CRI	CRI R9	TM30 R _f	TM30 R _g	TLCI	CQS	x	Y	Δuv	SSIt	SSId
92.1	89.8	88.6	103.0	93	89.8	0.313	0.322	-0.0005	25	57

CIE 1931

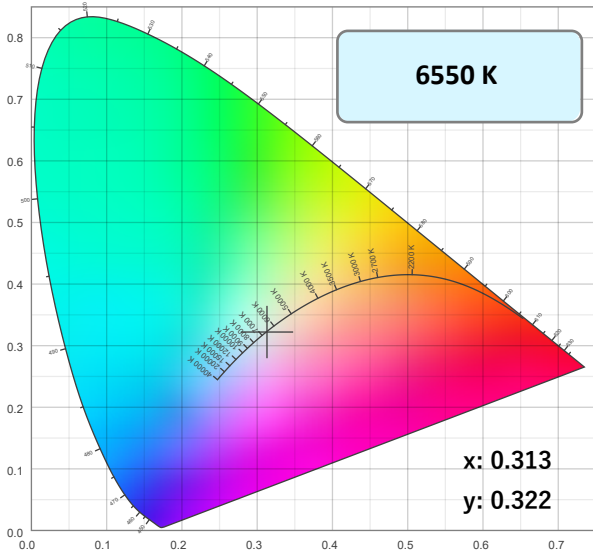

CIE 1931 ZOOMED

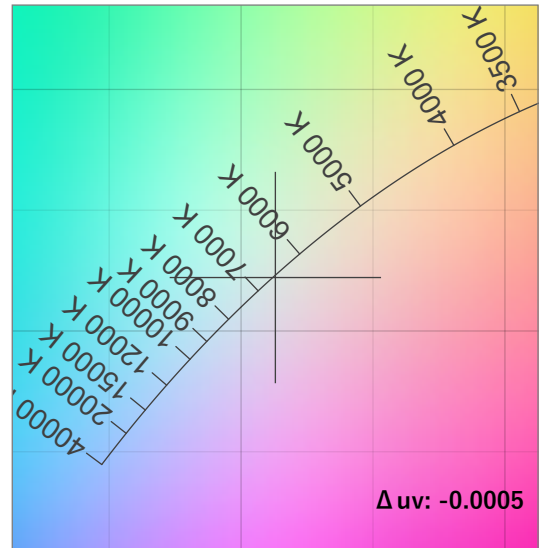

CRI: 92.1 (R1-R8)

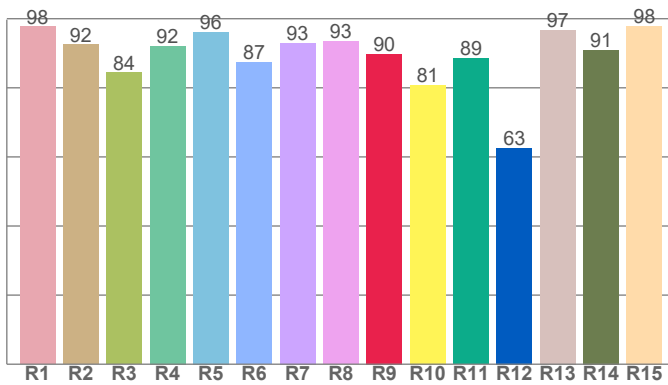

Spectral Power Distribution (SPD)

Dominant Wavelength 549 nm

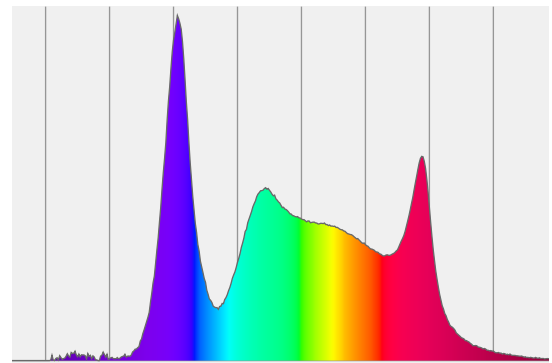

SSI Spectral Variance Graph- Tungsten

SSI [CIE A] 25

Spectral variance

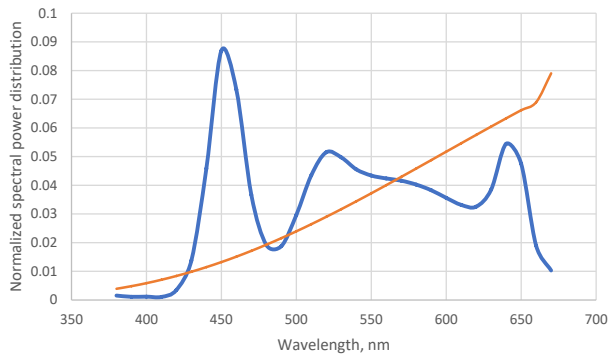

— Test Source — CIE Illuminant A - Tungsten

SSI Spectral Variance Graph- Daylight

SSI [CIE D65] 57

Spectral variance

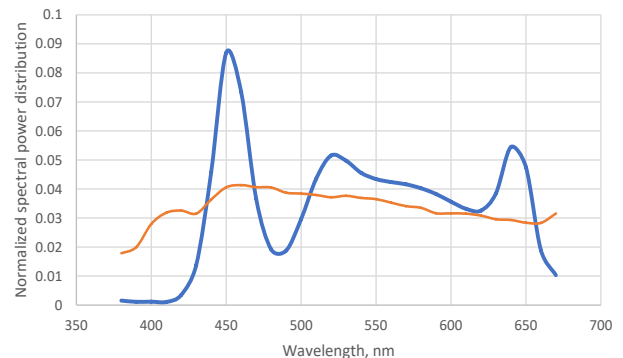

— Test Source — CIE Illuminant D65 - Daylight

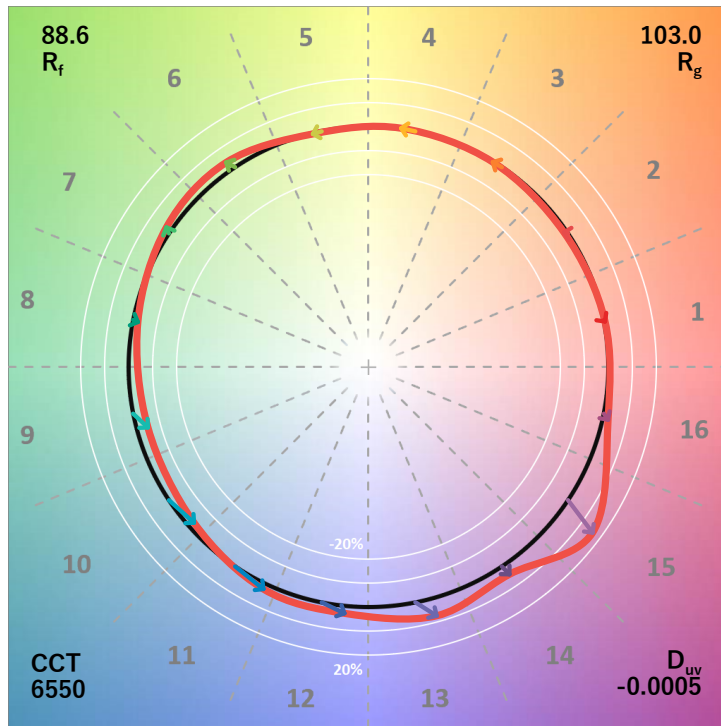

TM30-18 R_f Values per Hue Bin

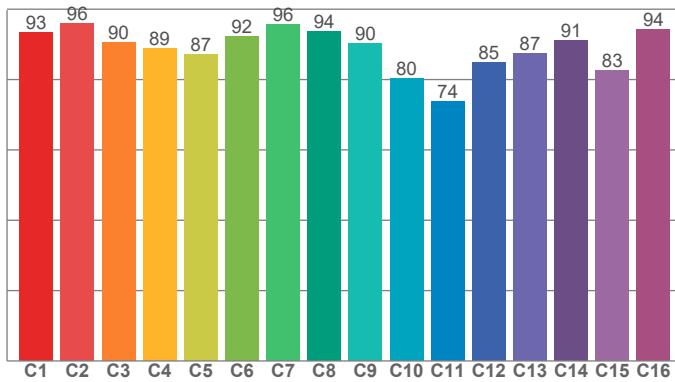

TM30 Chroma Shift per Hue Bin

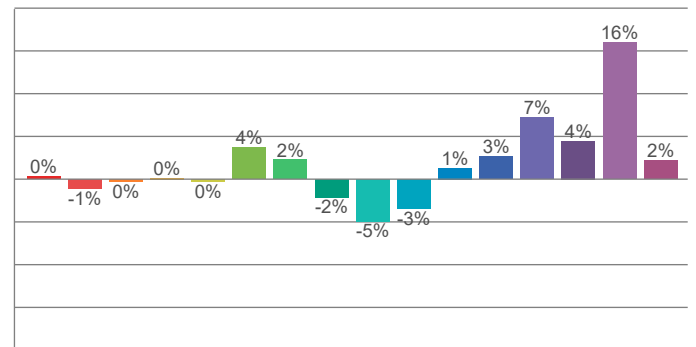

TM30-18 R_f Values per Reference Color (CES)

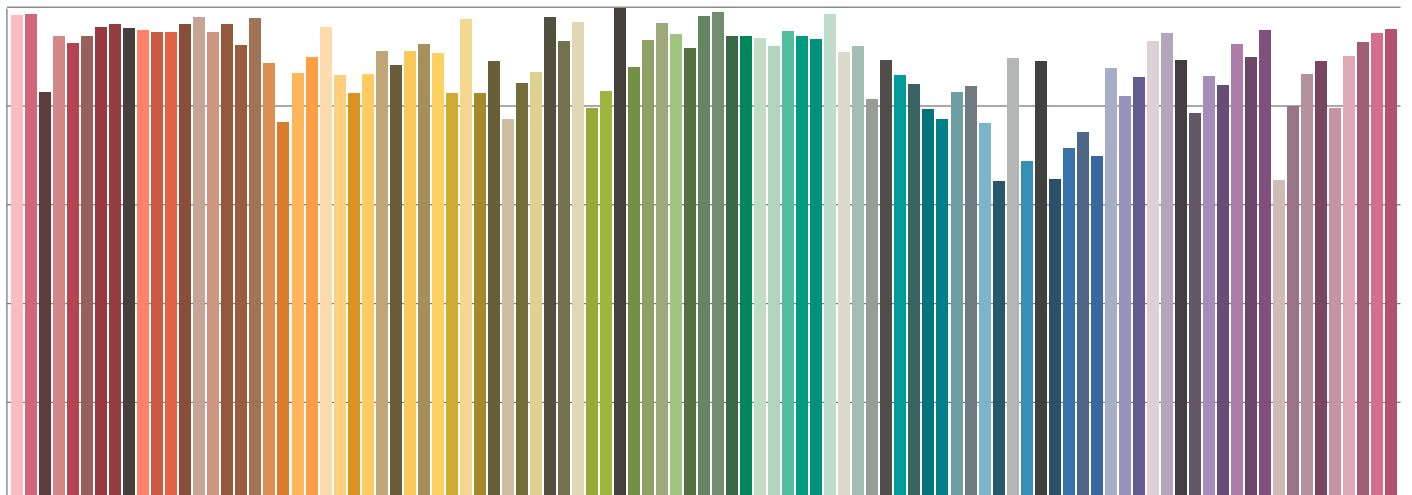

Color Temperature: 8256K

Accuracy Metric Overview

Color Rendering Index	Color Rendering Index, R9 (Red Component)	TM-30 Color Fidelity	TM-30 Color Gamut	Television Lighting Consistency Index	Color Quality Scale	Color Coordinate- CIE 1931	Color Coordinate- CIE 1931	Deviation from Black Body	SSI [CIE A] Tungsten	SSI [CIE D65] Daylight
CRI	CRI R9	TM30 R _f	TM30 R _g	TLCI	CQS	x	Y	Δuv	SSIt	SSId
83.8	32.3	80.5	95.0	69	78.2	0.294	0.300	-0.0017	5	52

CIE 1931

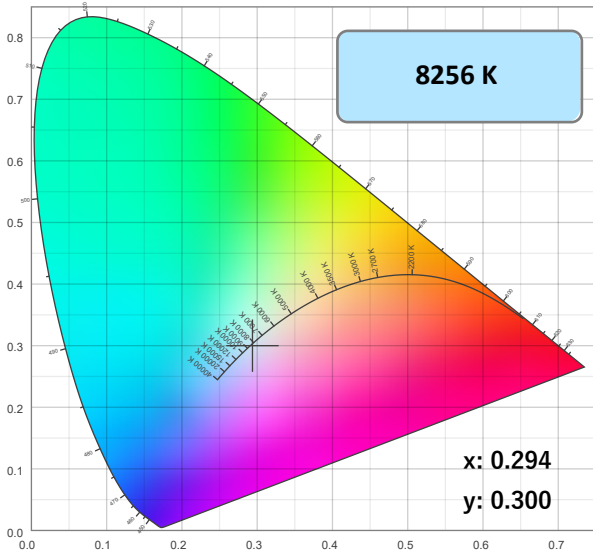

CIE 1931 ZOOMED

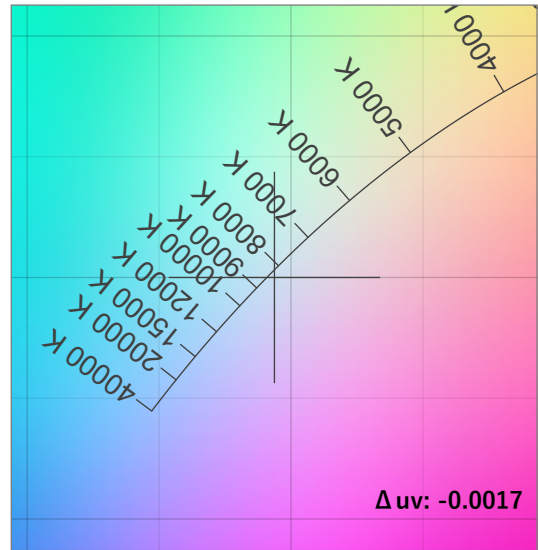

CRI: 83.8 (R1-R8)

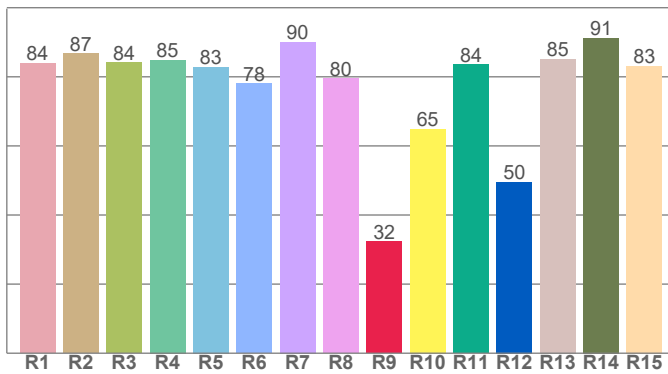

Spectral Power Distribution (SPD)

Dominant Wavelength 468 nm

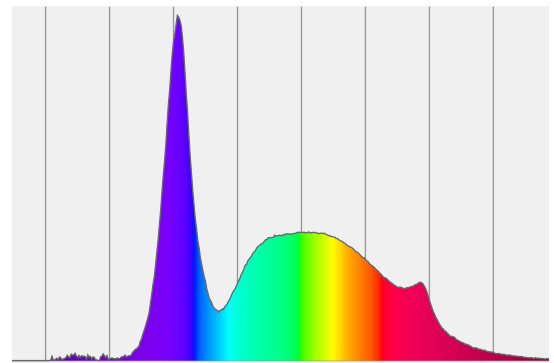

SSI Spectral Variance Graph- Tungsten

SSI [CIE A] 5

Spectral variance

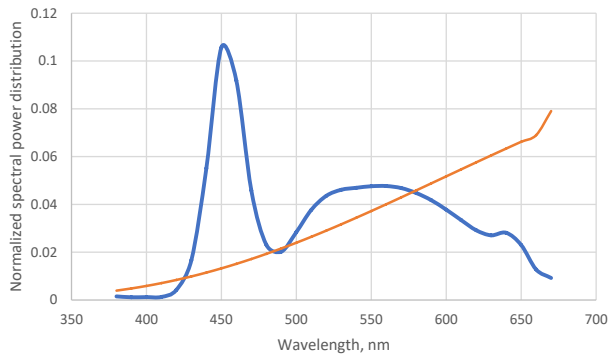

— Test Source — CIE Illuminant A - Tungsten

SSI Spectral Variance Graph- Daylight

SSI [CIE D65] 52

Spectral variance

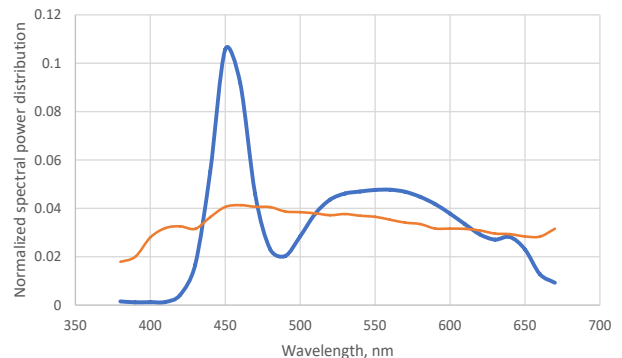

— Test Source — CIE Illuminant D65 - Daylight

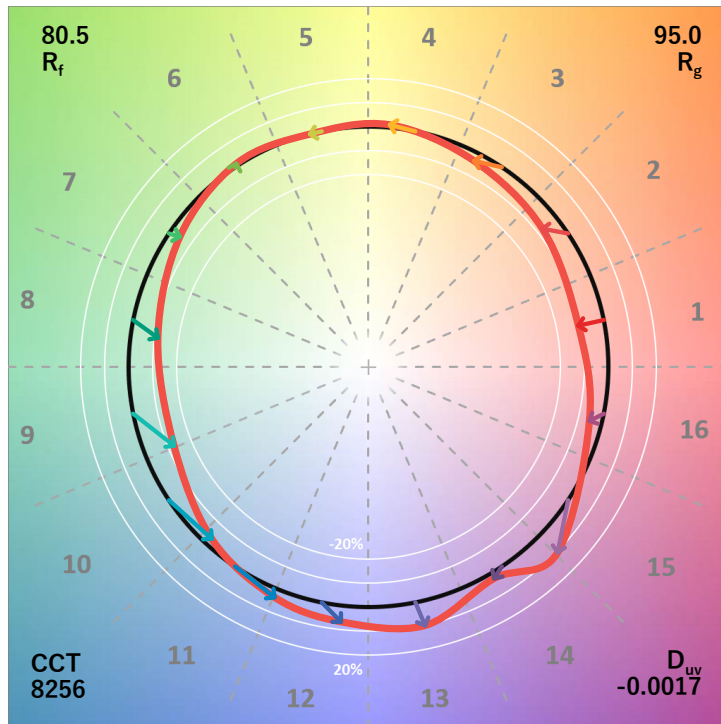

TM30-18 R_f Values per Hue Bin

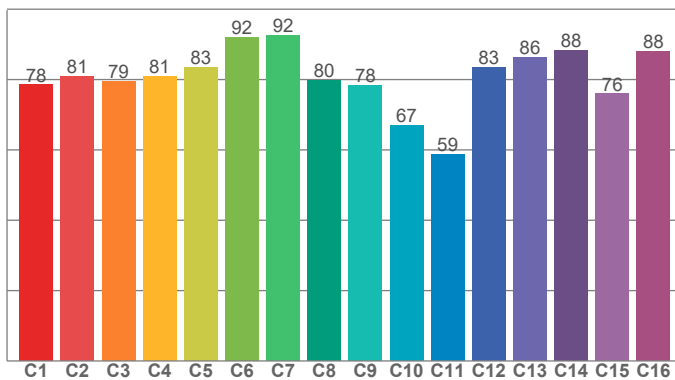

TM30 Chroma Shift per Hue Bin

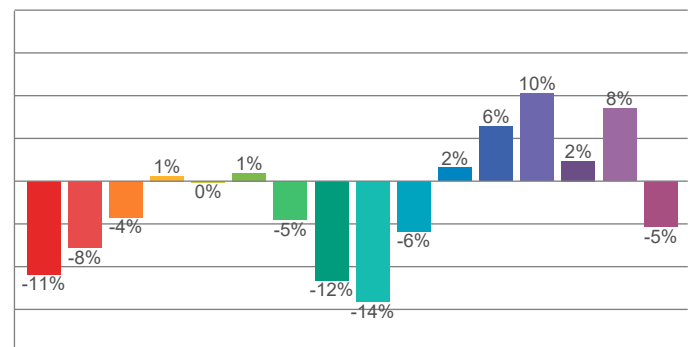

TM30-18 R_f Values per Reference Color (CES)

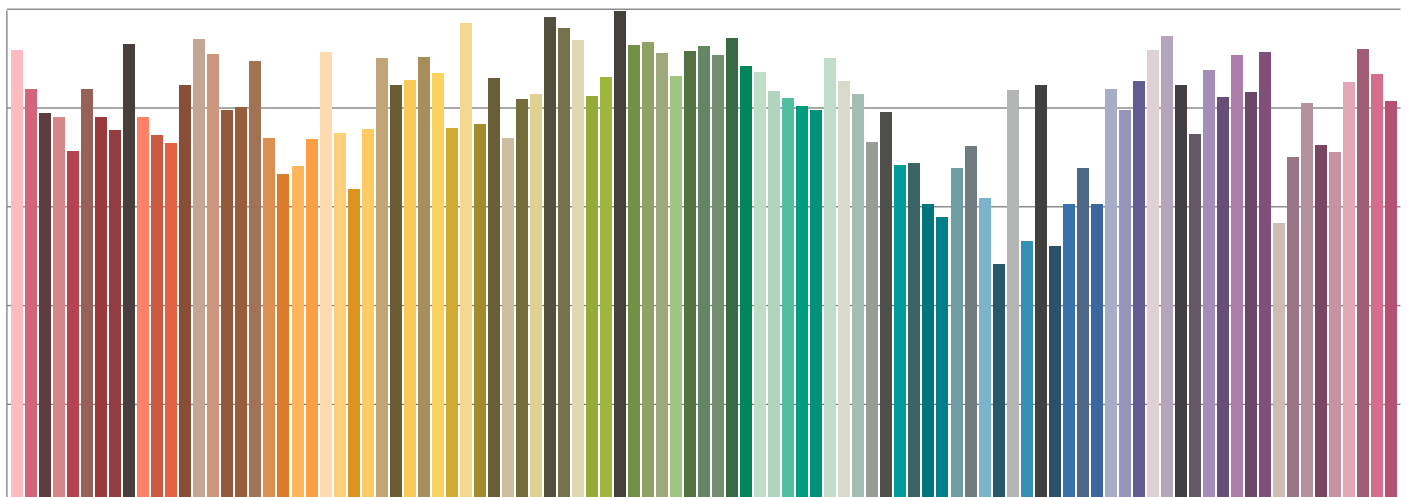

Measurements

Total Lumen Output: 1055 lm
 Peak Intensity: 5266 cd
 Efficacy: 12 Lumen/Watt
 Power: 87.3 W
 Voltage: 119 V, Current: 0.734 A

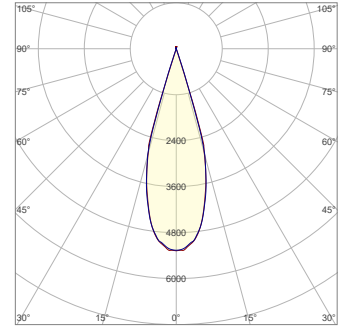
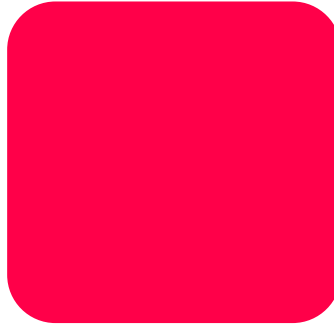

Spectral Power Distribution

Dominant Wavelength 630 nm

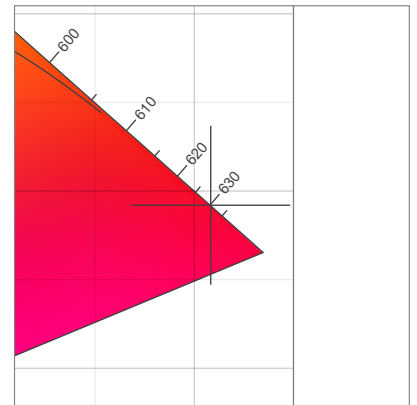
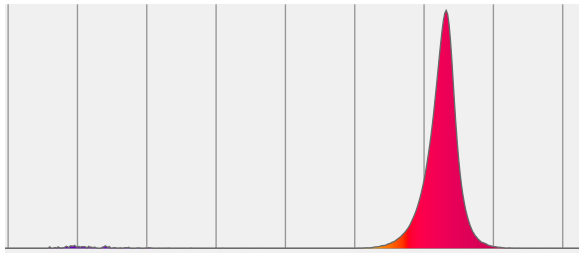

Dominant Wavelength	Color Coordinate CIE 1931	Color Coordinate CIE1931	Color Coordinate CIE 1964	Color Coordinate CIE 1964
nm	x	y	u	v
630	0.708	0.292	0.557	0.344

15 m 20 m 10 m 15 m 20 m
 8.4 m 11.2 m 5.6 m 8.4 m 11.2 m

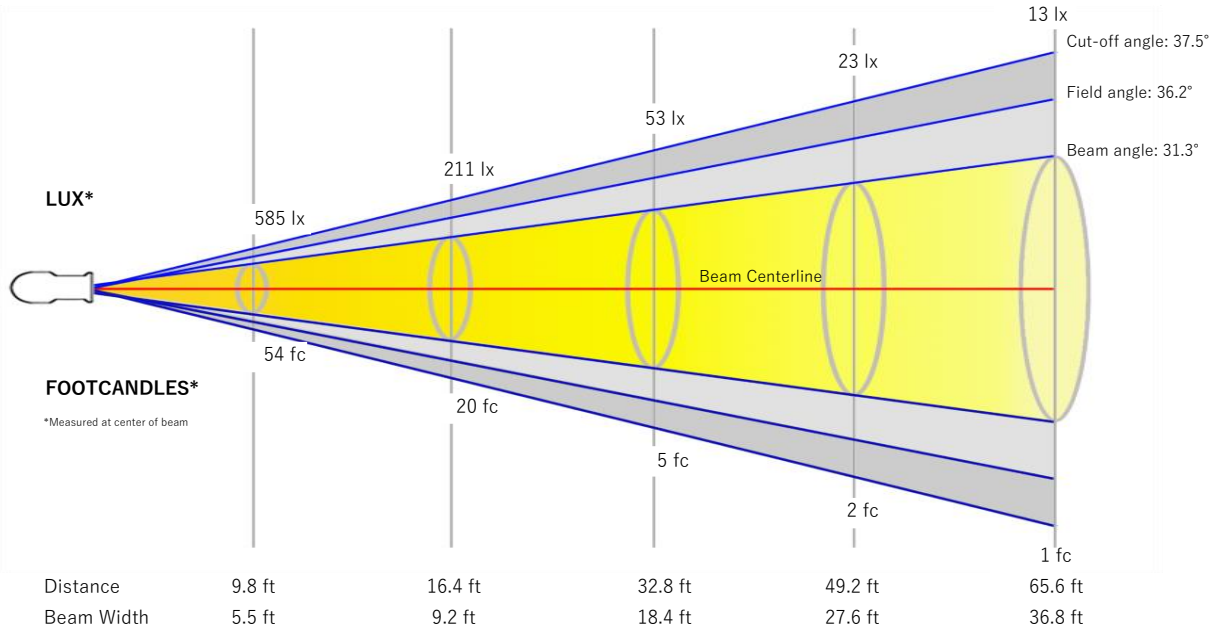

Beam Intensities from 1-20m

M	1	2	3	4	5	6	7	8	9	10	11	12	13	14	15	16	17	18	19	20
FT	3.3	6.6	9.8	13.1	16.4	19.7	23	26.2	29.5	32.8	36.1	39.4	42.7	45.9	49.2	52.5	55.8	59.1	62.3	65.6
LX	5266	1316	585	329	211	146	107	82	65	53	44	37	31	27	23	21	18	16	15	13
FC	489.2	122.3	54.4	30.6	19.6	13.6	10	7.6	6	4.9	4	3.4	2.9	2.5	2.2	1.9	1.7	1.5	1.4	1.2

Measurements

Total Lumen Output: 1048 lm
 Peak Intensity: 4992 cd
 Efficacy: 17 Lumen/Watt
 Power: 61.2 W
 Voltage: 119 V, Current: 0.514 A

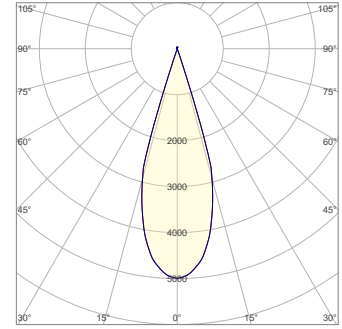
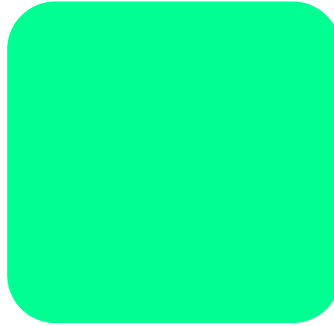

Spectral Power Distribution

Dominant Wavelength 523 nm

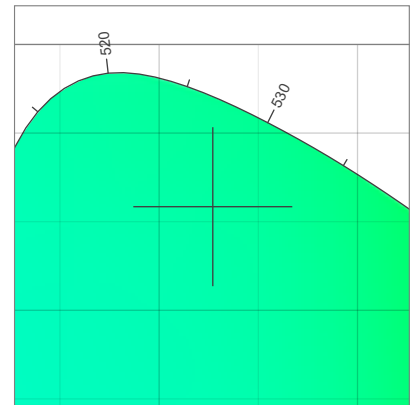
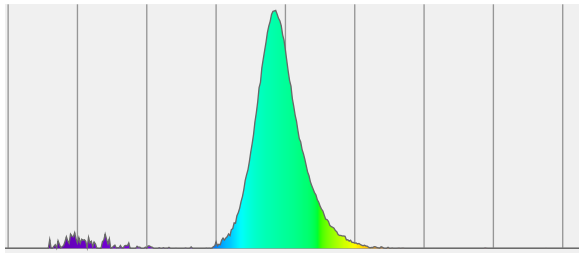

Dominant Wavelength	Color Coordinate CIE 1931	Color Coordinate CIE1931	Color Coordinate CIE 1964	Color Coordinate CIE 1964
nm	x	y	u	v
523	0.127	0.758	0.043	0.384

15 m 20 m 10 m 15 m 20 m
 8.7 m 11.6 m 5.8 m 8.7 m 11.6 m

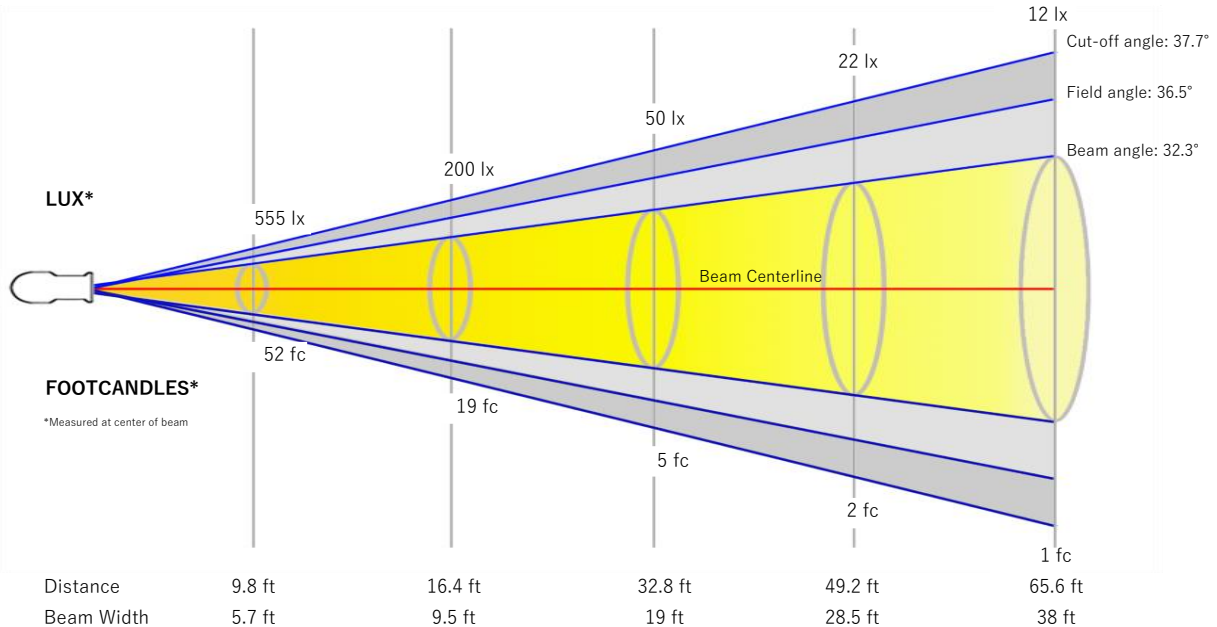

Beam Intensities from 1-20m

M	1	2	3	4	5	6	7	8	9	10	11	12	13	14	15	16	17	18	19	20
FT	3.3	6.6	9.8	13.1	16.4	19.7	23	26.2	29.5	32.8	36.1	39.4	42.7	45.9	49.2	52.5	55.8	59.1	62.3	65.6
LX	4992	1248	555	312	200	139	102	78	62	50	41	35	30	25	22	20	17	15	14	12
FC	463.8	115.9	51.5	29	18.6	12.9	9.5	7.2	5.7	4.6	3.8	3.2	2.7	2.4	2.1	1.8	1.6	1.4	1.3	1.2

Measurements

Total Lumen Output: 279 lm
 Peak Intensity: 1412 cd
 Efficacy: 3 Lumen/Watt
 Power: 86.7 W
 Voltage: 119 V, Current: 0.729 A

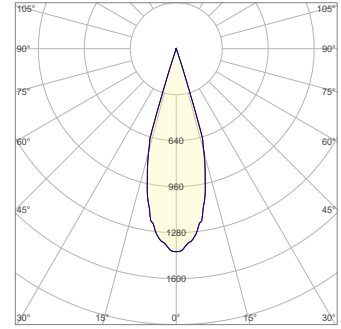
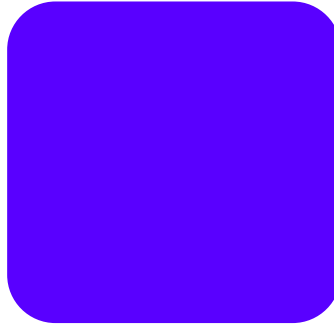

Spectral Power Distribution

Dominant Wavelength 455 nm

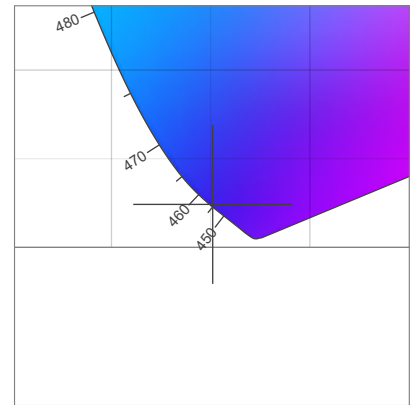
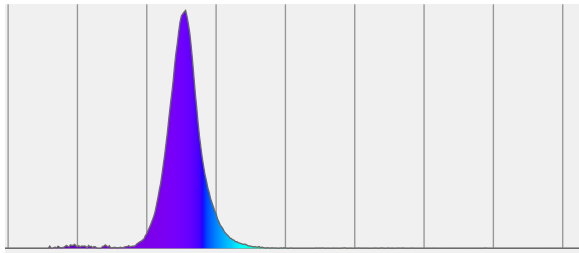

Dominant Wavelength	Color Coordinate CIE 1931	Color Coordinate CIE1931	Color Coordinate CIE 1964	Color Coordinate CIE 1964
nm	x	y	u	v
455	0.151	0.024	0.202	0.049

15 m 20 m 10 m 15 m 20 m
 8.3 m 11 m 5.5 m 8.3 m 11 m

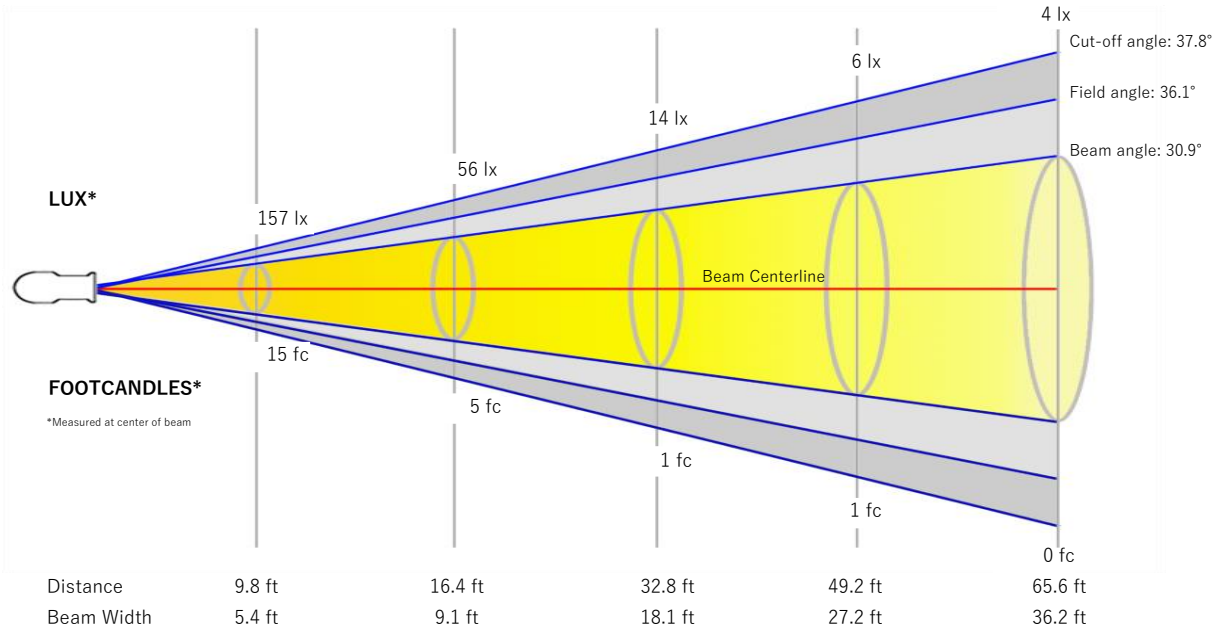

Beam Intensities from 1-20m

M	1	2	3	4	5	6	7	8	9	10	11	12	13	14	15	16	17	18	19	20
FT	3.3	6.6	9.8	13.1	16.4	19.7	23	26.2	29.5	32.8	36.1	39.4	42.7	45.9	49.2	52.5	55.8	59.1	62.3	65.6
LX	1412	353	157	88	56	39	29	22	17	14	12	10	8	7	6	6	5	4	4	4
FC	131.1	32.8	14.6	8.2	5.2	3.6	2.7	2	1.6	1.3	1.1	0.9	0.8	0.7	0.6	0.5	0.5	0.4	0.4	0.3

Measurements

Total Lumen Output: 1048 lm
 Peak Intensity: 4992 cd
 Efficacy: 17 Lumen/Watt
 Power: 61.2 W
 Voltage: 119 V, Current: 0.514 A

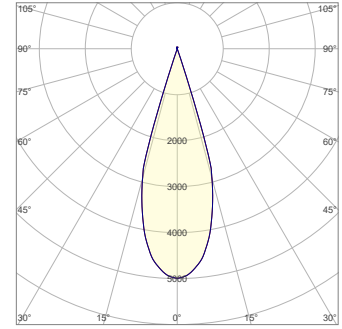
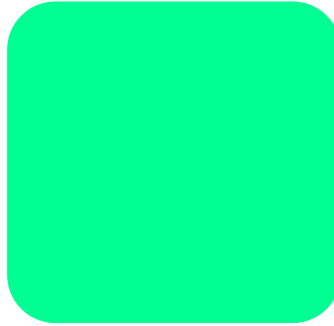

Spectral Power Distribution

Dominant Wavelength 523 nm

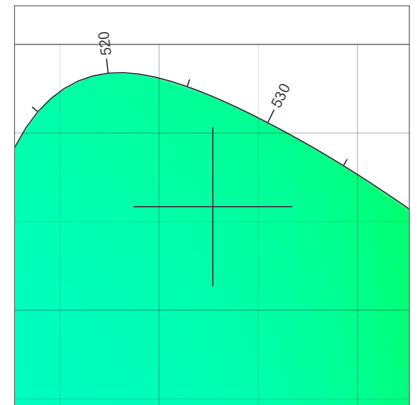
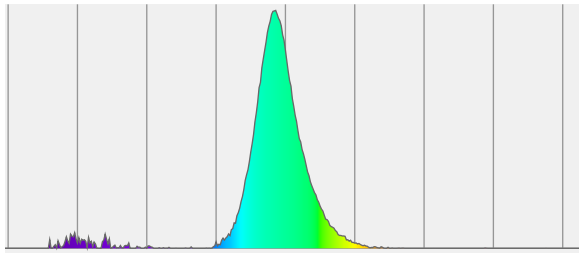

Dominant Wavelength	Color Coordinate CIE 1931	Color Coordinate CIE1931	Color Coordinate CIE 1964	Color Coordinate CIE 1964
nm	x	y	u	v
523	0.127	0.758	0.043	0.384

15 m 20 m 10 m 15 m 20 m
 8.7 m 11.6 m 5.8 m 8.7 m 11.6 m

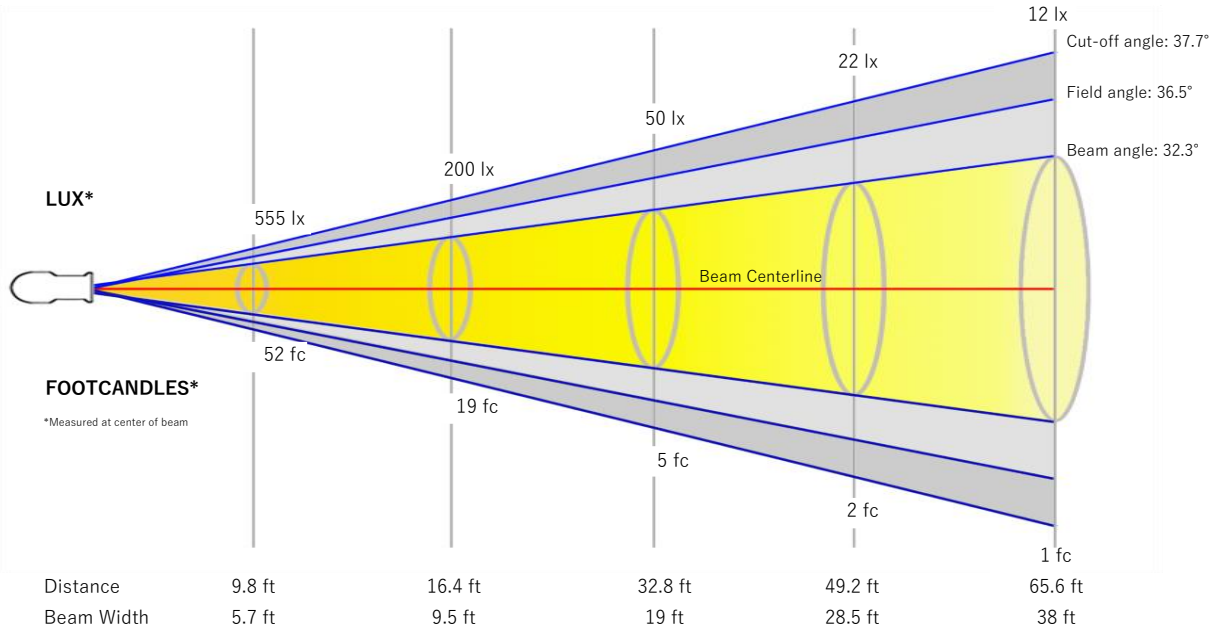

Beam Intensities from 1-20m

M	1	2	3	4	5	6	7	8	9	10	11	12	13	14	15	16	17	18	19	20
FT	3.3	6.6	9.8	13.1	16.4	19.7	23	26.2	29.5	32.8	36.1	39.4	42.7	45.9	49.2	52.5	55.8	59.1	62.3	65.6
LX	4992	1248	555	312	200	139	102	78	62	50	41	35	30	25	22	20	17	15	14	12
FC	463.8	115.9	51.5	29	18.6	12.9	9.5	7.2	5.7	4.6	3.8	3.2	2.7	2.4	2.1	1.8	1.6	1.4	1.3	1.2

Measurements

Total Lumen Output: 1371 lm
 Peak Intensity: 6913 cd
 Efficacy: 14 Lumen/Watt
 Power: 101 W
 Voltage: 119 V, Current: 0.849 A

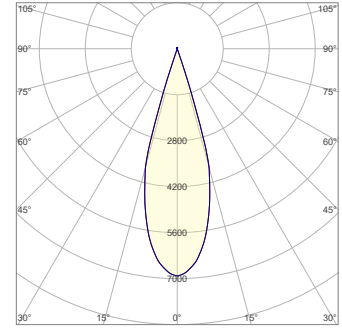

Spectral Power Distribution

Dominant Wavelength 592 nm

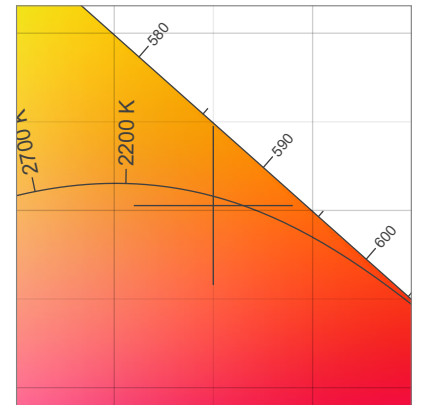
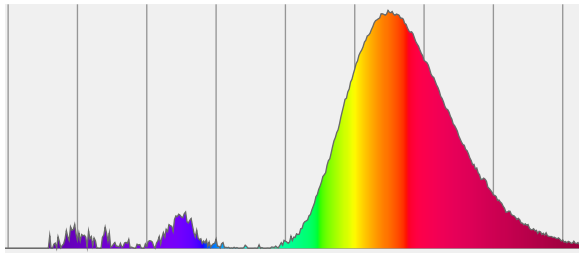

Dominant Wavelength	Color Coordinate CIE 1931	Color Coordinate CIE1931	Color Coordinate CIE 1964	Color Coordinate CIE 1964
nm	x	y	u	v
592	0.550	0.403	0.327	0.359

15 m 20 m 10 m 15 m 20 m
 8.3 m 11.1 m 5.5 m 8.3 m 11.1 m

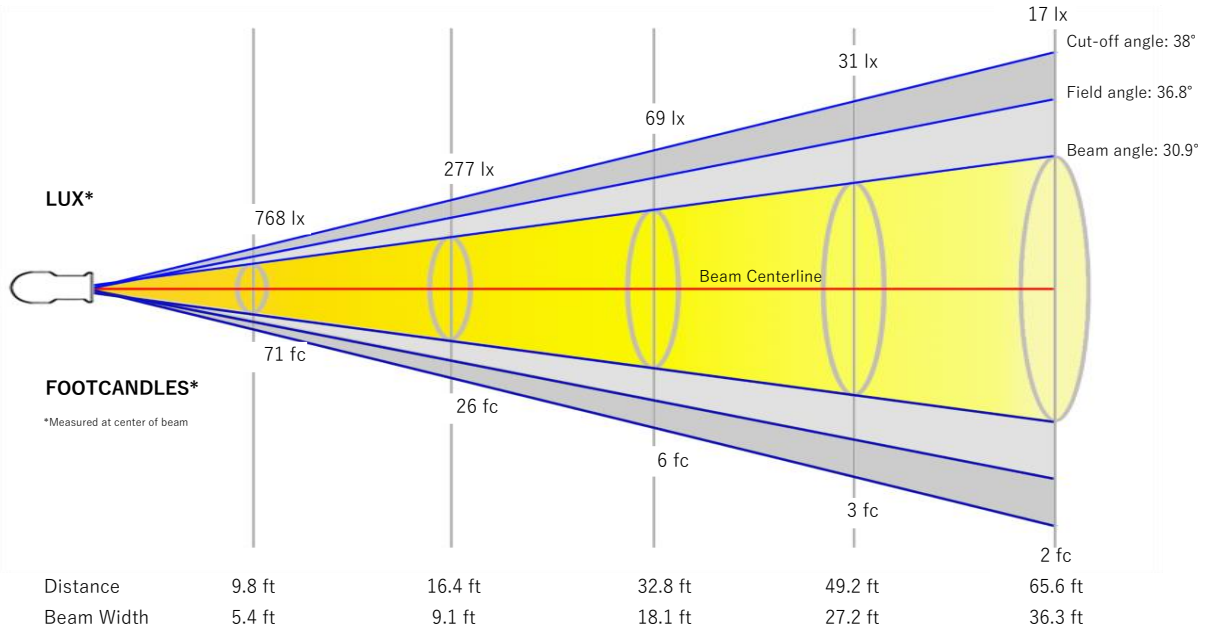

Beam Intensities from 1-20m

M	1	2	3	4	5	6	7	8	9	10	11	12	13	14	15	16	17	18	19	20
FT	3.3	6.6	9.8	13.1	16.4	19.7	23	26.2	29.5	32.8	36.1	39.4	42.7	45.9	49.2	52.5	55.8	59.1	62.3	65.6
LX	6913	1728	768	432	277	192	141	108	85	69	57	48	41	35	31	27	24	21	19	17
FC	642.2	160.6	71.4	40.1	25.7	17.8	13.1	10	7.9	6.4	5.3	4.5	3.8	3.3	2.9	2.5	2.2	2	1.8	1.6