



KL PAR IP COMPACT

Photometric &
Chromaticity Test Reports

CONTENTS

Testing Procedures	4
Photometric Output Reports	5
VNSP Lens (10)	5
Full Output	5
3200K	7
4500K	9
6500K	11
8500K	13
NSP Lens (22)	15
Full Output	15
3200K	17
4500K	19
6500K	21
8500K	23
MFL Lens (30)	25
Full Output	25
2400K	27
3200K	29
4500K	31
5600K	33
6000K	35
6500K	37
7500K	39
8500K	41
WFL Lens (55)	43
Full Output	43
3200K	45
4500K	47
6500K	49
8500K	51

Color Quality Reports	53
Full Output.....	53
2700K.....	55
3200K.....	57
4500K.....	59
5600K.....	61
6000K.....	63
6500K.....	65
7500K.....	67
8500K.....	69

LED Color Information Reports	71
Red.....	71
Green.....	72
Blue.....	73
Mint	74
Amber	75

©2026 ELATION PROFESSIONAL all rights reserved. Information, specifications, diagrams, images, and instructions herein are subject to change without notice. ELATION PROFESSIONAL logo and identifying product names and numbers herein are trademarks of ELATION PROFESSIONAL. Copyright protection claimed includes all forms and matters of copyrightable materials and information now allowed by statutory or judicial law or hereinafter granted. Product names used in this document may be trademarks or registered trademarks of their respective companies and are hereby acknowledged. All non-ELATION brands and product names are trademarks or registered trademarks of their respective companies.

Elation Professional USA | 6122 S. Eastern Ave. | Los Angeles, CA. 90040
323-582-3322 | 323-832-9142 fax | www.elationlighting.com | info@elationlighting.com

Elation Professional B.V. | Junostraat 2 | 6468 EW Kerkrade, The Netherlands
+31 45 546 85 66 | +31 45 546 85 96 fax | www.elationlighting.eu | info@elationlighting.eu

Elation Professional Mexico | AV Santa Ana 30 | Parque Industrial Lerma, Lerma, Mexico 52000
+52 (728) 282-7070

Testing Process

Total Lumen Measurements

Lumens are measured using a Viso Systems Lab Spion. As a goniophotometer, the Viso calculates the field lumens of the fixture by taking multiple measurements across the light beam.

Many lumens figures provided for entertainment lighting fixtures are only 2π sphere values, some even emphasize the LED engine lumens. All Elation product photometric data is the actual light output from the fixture lens, never a theoretical value based on calculation or using the source lumens as the fixtures output. We advise to always compare total fixture lumens acquired with identical measurement systems when comparing lighting fixtures.

Test Lab Equipment and Process

Elation operates an optical testing laboratory at its Los Angeles, CA headquarters to provide accurate photometric data for its lighting products. The testing lab is both light and climate- controlled and contains a variety of precise lighting measurement systems. Fixtures are analyzed with the sophisticated [Viso Systems Lab Spion](#) equipment, which measures all light and color parameters by panning the light beam at a precise speed and from different angles through a calibrated, laser aligned light and color sensor. Test data is collected and summarized by the Viso Light Inspector software. This type of measurement system is referred to as a Goniophotometer.

The Viso software calculates all relevant types of measurements, from beam angles, candela to center light intensity at a variety of distances to the latest color quality measurements like TM30 or CQS as well as accurate color temperature. This wealth of data is then processed by an Elation specific template which is included in the photometric test report for various fixture conditions such as zoom angles and color correction filters.

The Viso software also creates IES (Illuminating Engineering Society) files for each test report. IES is an industry standard file format created for the easy electronic transfer of photometric test data, which is widely used by lighting manufacturers for photometric data distribution.

Additionally, fixtures are periodically rechecked for accuracy using various hand-held light meters including one or more of the devices listed below. This is done to ensure the test data contained in this report is as accurate as possible.

[Asenstek Lighting Passport](#) | [Konica Minolta T-10](#) | [Sekonic C800U](#)

Key Measurements

Output

Total Lumen Output: 4291 lm

Peak Intensity: 65975 cd

Beam

Beam Angle (50%): 11.2°

Field Angle (10%): 22.2°

Cutoff Angle (2.5%): 33.3°

Color

Color Temperature: 5914 K

CRI: 88.8

TLCI: 90

TM30 R_F: 88.0

TM30 R_g: 107.3

Power Details

Efficacy: 28 Lumen/Watt

Power: 153.8 W

Supply Voltage: 118 V

Current: 1.30 A

Beam Details

Distance	3 m	5 m	10 m	15 m	20 m
Beam Width	0.6 m	1 m	2 m	2.9 m	3.9 m

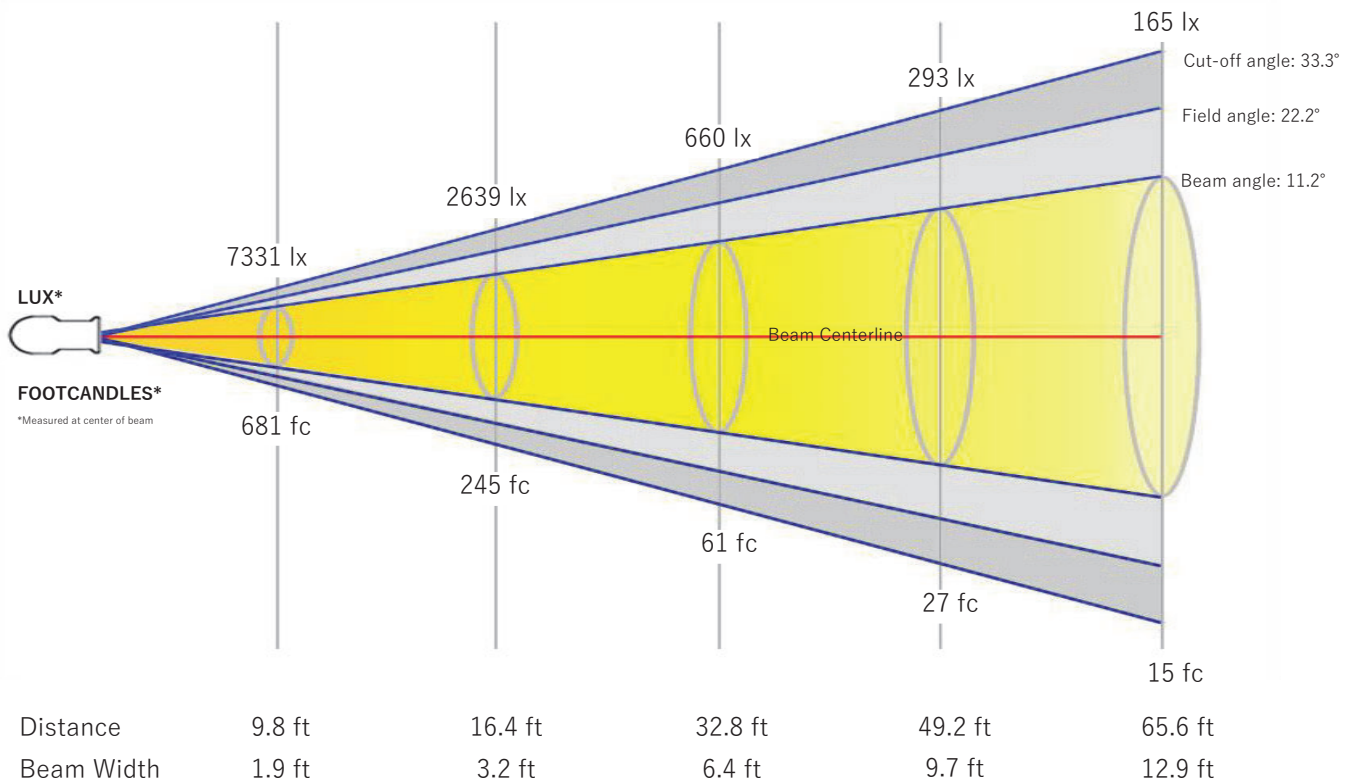

Beam Intensities from 1-20m

M	1	2	3	4	5	6	7	8	9	10	11	12	13	14	15	16	17	18	19	20
LX	65975	16494	7331	4123	2639	1833	1346	1031	815	660	545	458	390	337	293	258	228	204	183	165
FT	3.3	6.6	9.8	13.1	16.4	19.7	23	26.2	29.5	32.8	36.1	39.4	42.7	45.9	49.2	52.5	55.8	59.1	62.3	65.6
FC	6129.3	1532.3	681	383.1	245.2	170.3	125.1	95.8	75.7	61.3	50.7	42.6	36.3	31.3	27.2	23.9	21.2	18.9	17	15.3

Angular Distribution

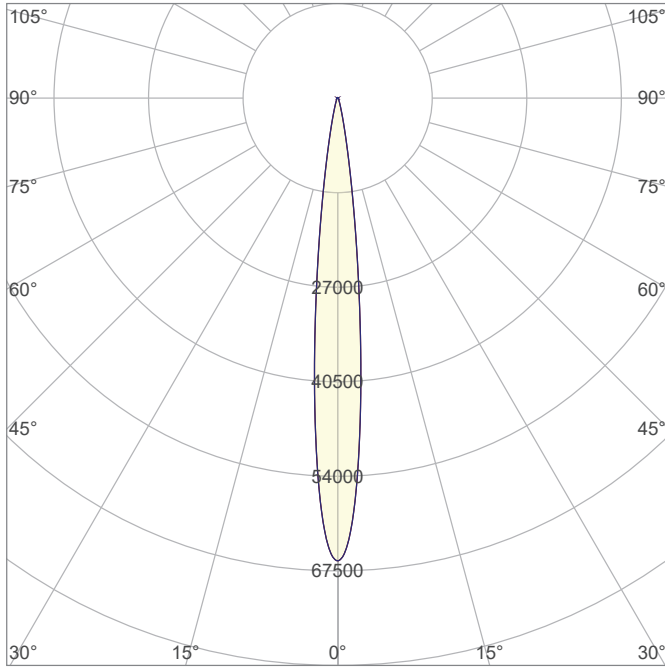

Beam Angle - 50%
11.2°
Field Angle - 10%
22.2°
Cutoff Angle - 2.5%
33.3°

ISO Diagrams

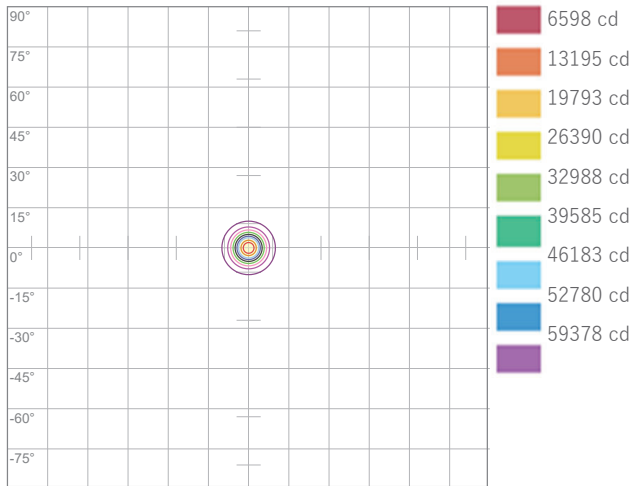

ISO Candela Diagram

Conditions:
Number of c-planes: 4
Candela at center: 65975 cd

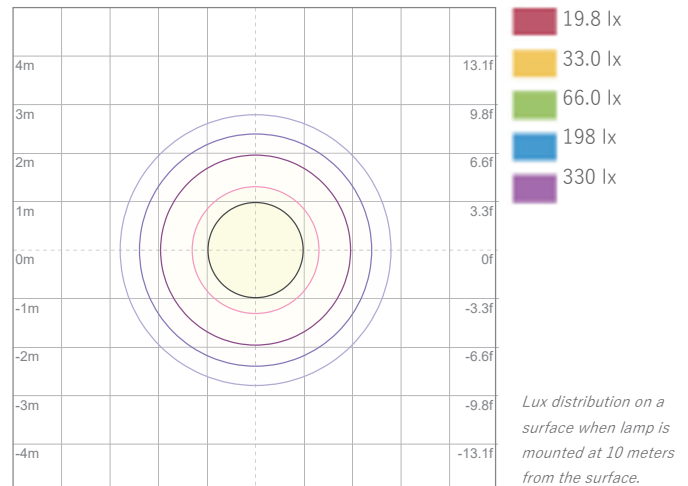

ISO LUX Diagram

Conditions:
Number of c-planes: 4
LUX at center: 660 lx

Lux distribution on a surface when lamp is mounted at 10 meters from the surface.

Linear Distribution

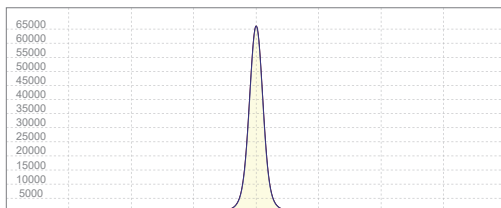

Peak Candela
65975 cd

Calculate Center Beam Intensities

$$\text{lux} = 65975 / \text{distance(m)}^2$$

$$\text{fc} = 65975 / \text{distance(ft)}^2$$

Key Measurements

Output

Total Lumen Output: 4551 lm
Peak Intensity: 68699 cd

Beam

Beam Angle (50%): 11.2°
Field Angle (10%): 22°
Cutoff Angle (2.5%): 33°

Color

Color Temperature: 3221 K
CRI: 90.3
TLCI: 92
TM30 R_F: 91.6
TM30 R_g: 106.8

Power Details

Efficacy: 30 Lumen/Watt
Power: 152.2 W
Supply Voltage: 119 V
Current: 1.28 A

Beam Details

Distance	3 m	5 m	10 m	15 m	20 m
Beam Width	0.6 m	1 m	2 m	2.9 m	3.9 m

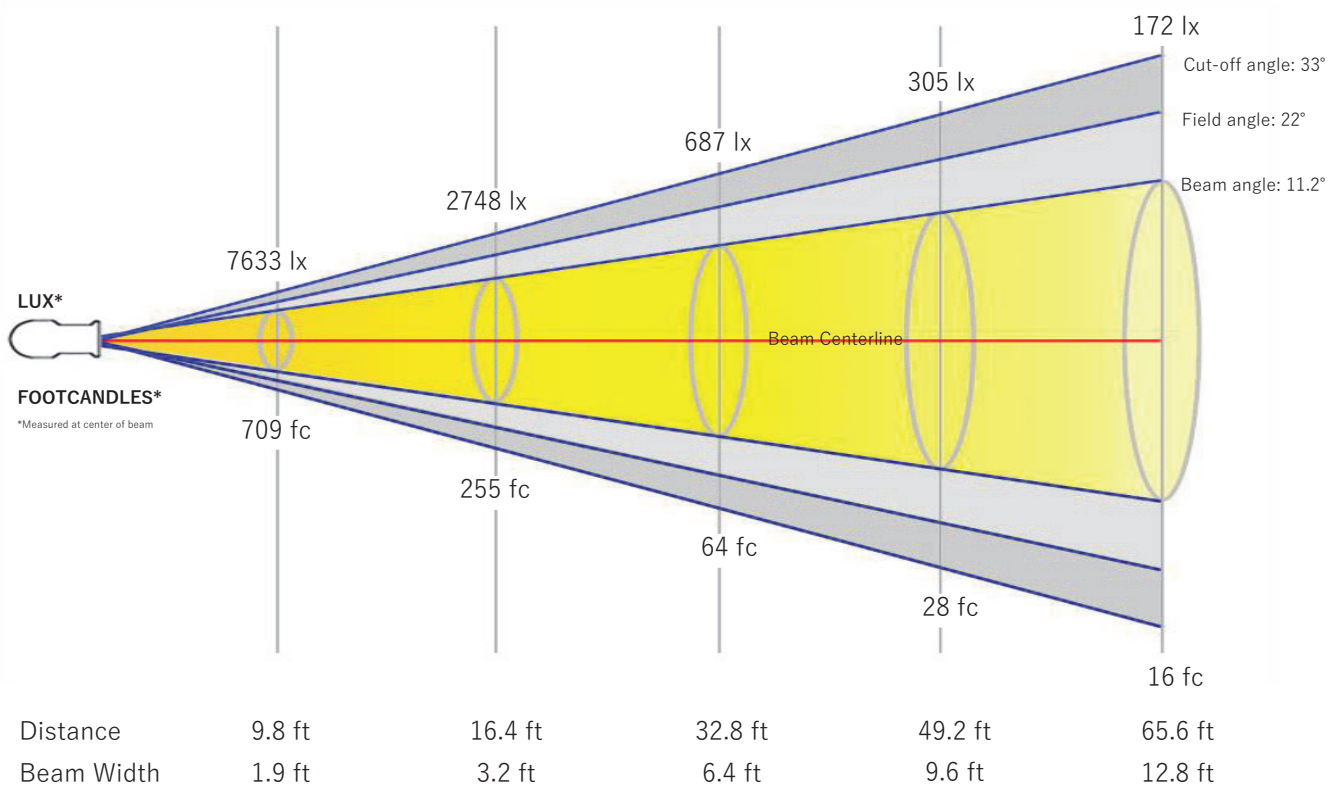

Beam Intensities from 1-20m

M	1	2	3	4	5	6	7	8	9	10	11	12	13	14	15	16	17	18	19	20
LX	68699	17175	7633	4294	2748	1908	1402	1073	848	687	568	477	407	351	305	268	238	212	190	172
FT	3.3	6.6	9.8	13.1	16.4	19.7	23	26.2	29.5	32.8	36.1	39.4	42.7	45.9	49.2	52.5	55.8	59.1	62.3	65.6
FC	6382.4	1595.6	709.2	398.9	255.3	177.3	130.3	99.7	78.8	63.8	52.7	44.3	37.8	32.6	28.4	24.9	22.1	19.7	17.7	16

Angular Distribution

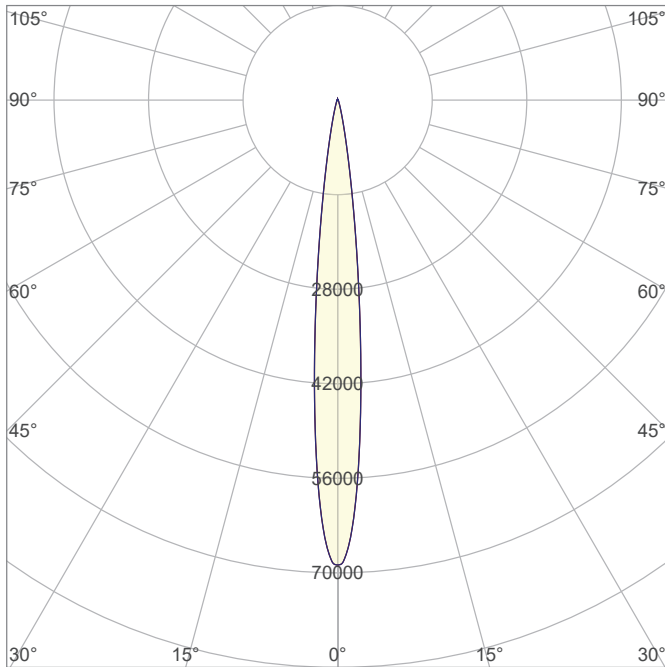

Beam Angle - 50%
11.2°
Field Angle - 10%
22°
Cutoff Angle - 2.5%
33°

ISO Diagrams

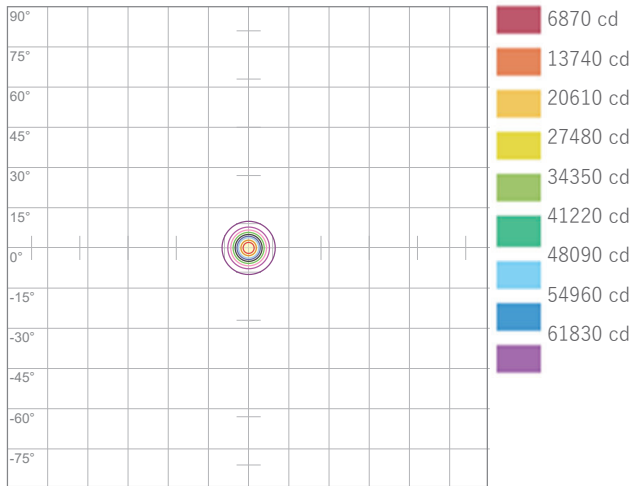

ISO Candela Diagram

Conditions:
Number of c-planes: 4
Candela at center: 68699 cd

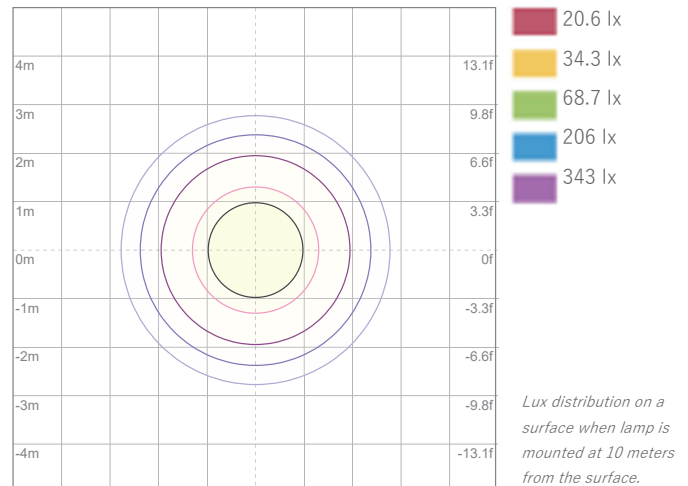

ISO LUX Diagram

Conditions:
Number of c-planes: 4
LUX at center: 687 lx

Linear Distribution

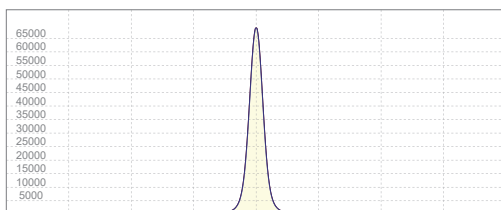

Peak Candela
68699 cd

Calculate Center Beam Intensities

$$\text{lux} = 68699 / \text{distance(m)}^2$$

$$\text{fc} = 68699 / \text{distance(ft)}^2$$

Key Measurements

Output

Total Lumen Output: 4315 lm

Peak Intensity: 66858 cd

Beam

Beam Angle (50%): 11.2°

Field Angle (10%): 22°

Cutoff Angle (2.5%): 33°

Color

Color Temperature: 4481 K

CRI: 86.1

TLCI: 87

TM30 R_F: 88.6

TM30 R_g: 109.5

Power Details

Efficacy: 36 Lumen/Watt

Power: 119 W

Supply Voltage: 151 V

Current: 0.791 A

Beam Details

Distance	3 m	5 m	10 m	15 m	20 m
Beam Width	0.6 m	1 m	2 m	2.9 m	3.9 m

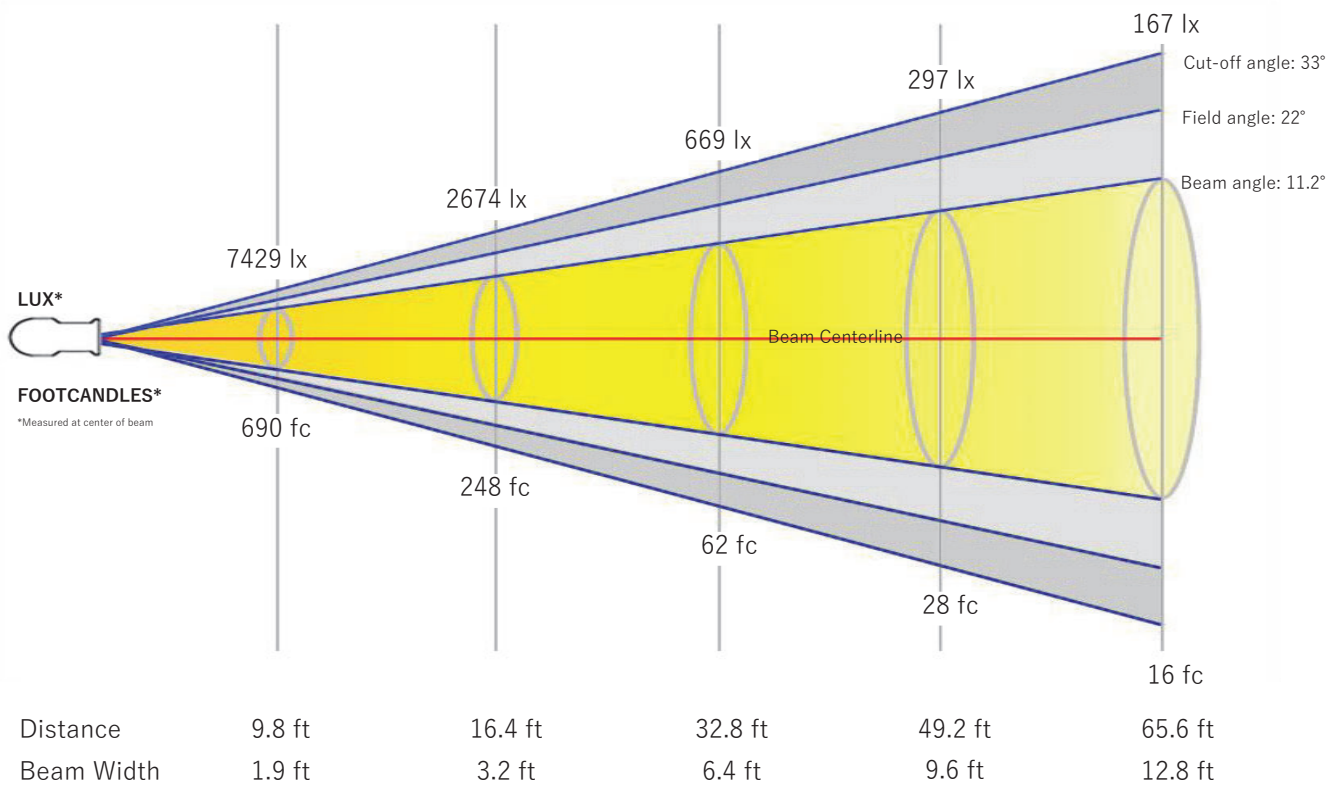

Beam Intensities from 1-20m

M	1	2	3	4	5	6	7	8	9	10	11	12	13	14	15	16	17	18	19	20
LX	66858	16715	7429	4179	2674	1857	1364	1045	825	669	553	464	396	341	297	261	231	206	185	167
FT	3.3	6.6	9.8	13.1	16.4	19.7	23	26.2	29.5	32.8	36.1	39.4	42.7	45.9	49.2	52.5	55.8	59.1	62.3	65.6
FC	6211.3	1552.8	690.1	388.2	248.5	172.5	126.8	97.1	76.7	62.1	51.3	43.1	36.8	31.7	27.6	24.3	21.5	19.2	17.2	15.5

Angular Distribution

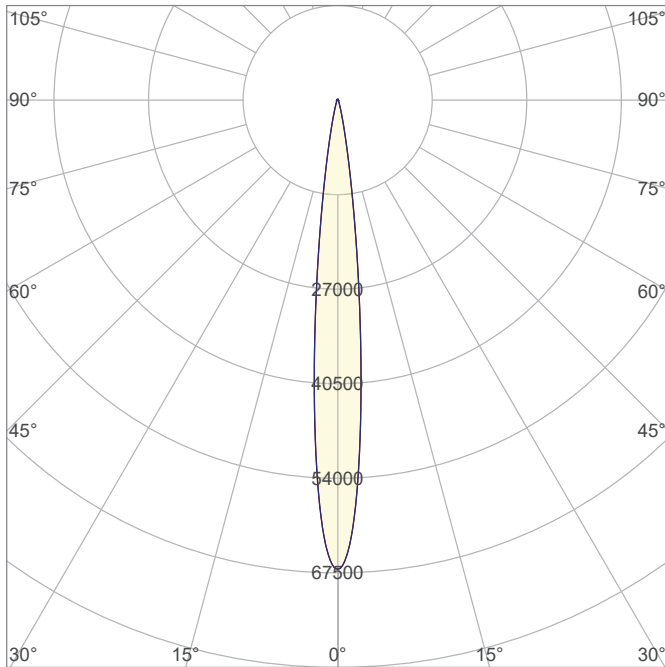

Beam Angle - 50%
11.2°
Field Angle - 10%
22°
Cutoff Angle - 2.5%
33°

ISO Diagrams

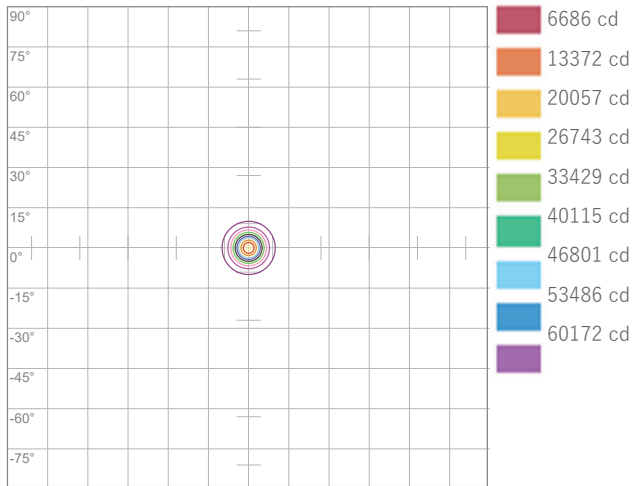

ISO Candela Diagram

Conditions:
Number of c-planes: 4
Candela at center: 66858 cd

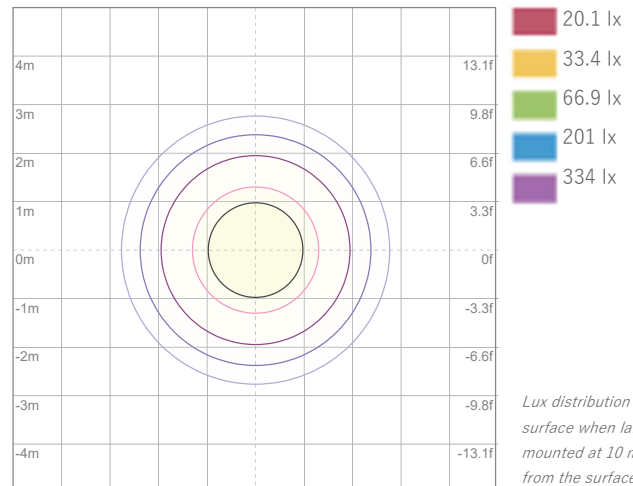

ISO LUX Diagram

Conditions:
Number of c-planes: 4
LUX at center: 669 lx

Lux distribution on a surface when lamp is mounted at 10 meters from the surface.

Linear Distribution

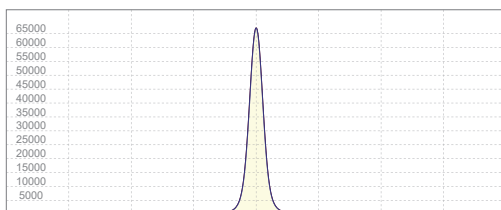

Peak Candela
66858 cd

Calculate Center Beam Intensities

$$\text{lux} = 66858 / \text{distance(m)}^2$$

$$\text{fc} = 66858 / \text{distance(ft)}^2$$

Key Measurements

Output

Total Lumen Output: 4207 lm

Peak Intensity: 65205 cd

Beam

Beam Angle (50%): 11.2°

Field Angle (10%): 22.1°

Cutoff Angle (2.5%): 33.1°

Color

Color Temperature: 6374 K

CRI: 89.6

TLCI: 91

TM30 R_F: 87.8

TM30 R_g: 106.3

Power Details

Efficacy: 28 Lumen/Watt

Power: 151.1 W

Supply Voltage: 118 V

Current: 1.28 A

Beam Details

Distance	3 m	5 m	10 m	15 m	20 m
Beam Width	0.6 m	1 m	2 m	2.9 m	3.9 m

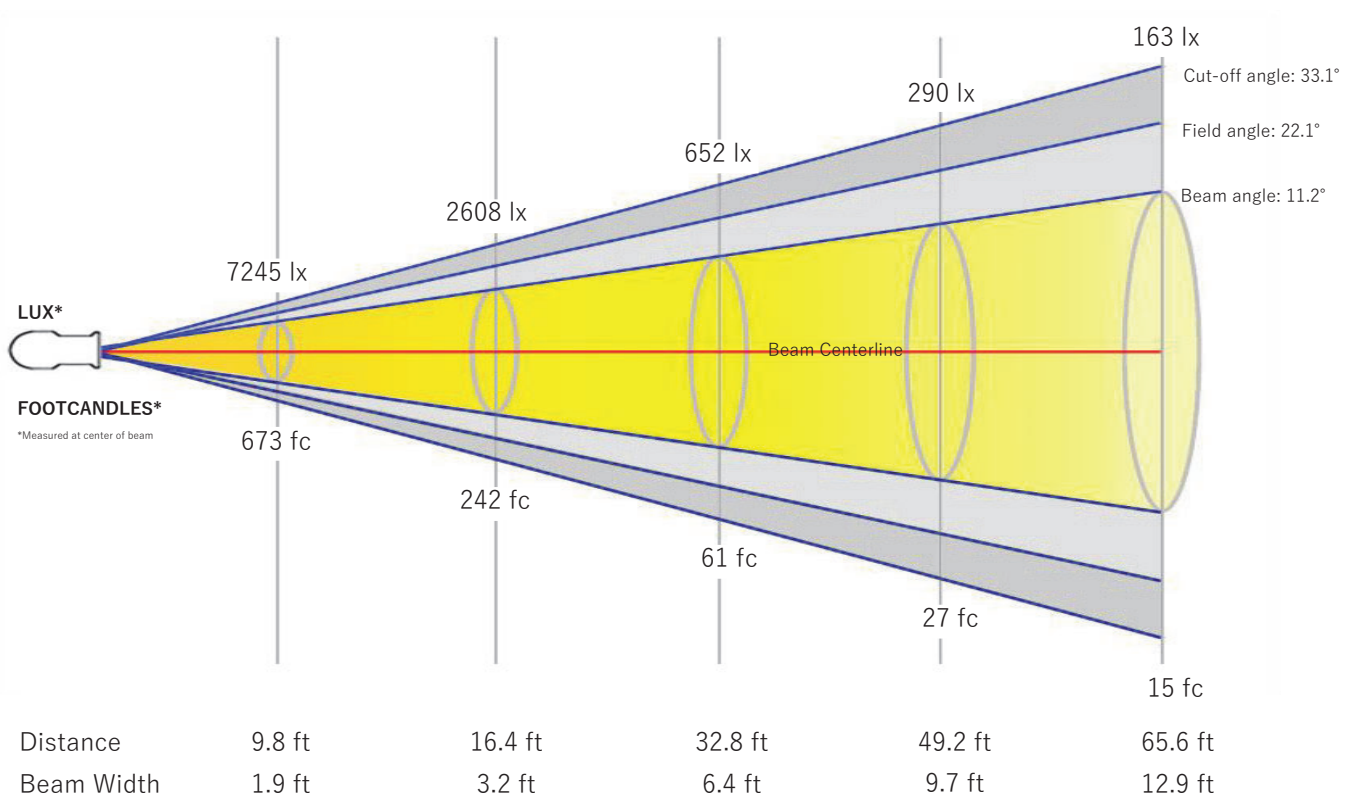

Beam Intensities from 1-20m

M	1	2	3	4	5	6	7	8	9	10	11	12	13	14	15	16	17	18	19	20
LX	65205	16301	7245	4075	2608	1811	1331	1019	805	652	539	453	386	333	290	255	226	201	181	163
FT	3.3	6.6	9.8	13.1	16.4	19.7	23	26.2	29.5	32.8	36.1	39.4	42.7	45.9	49.2	52.5	55.8	59.1	62.3	65.6
FC	6057.8	1514.4	673.1	378.6	242.3	168.3	123.6	94.7	74.8	60.6	50.1	42.1	35.8	30.9	26.9	23.7	21	18.7	16.8	15.1

Angular Distribution

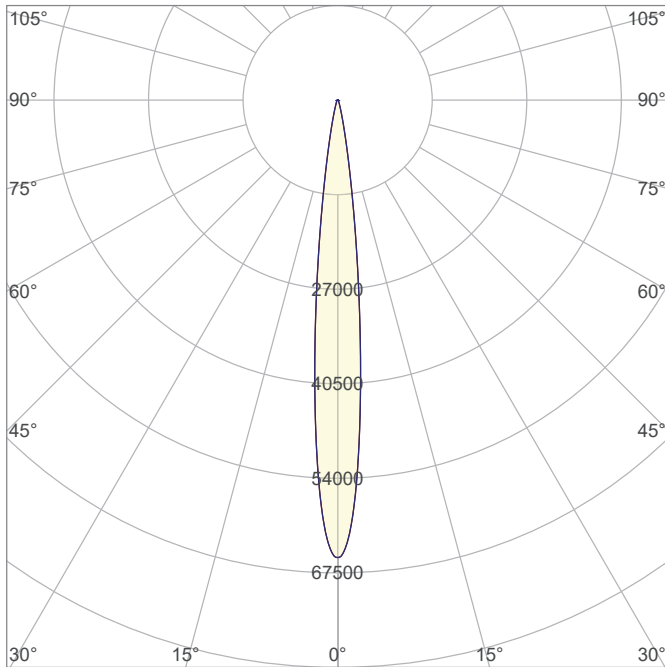

Beam Angle - 50%
11.2°
Field Angle - 10%
22.1°
Cutoff Angle - 2.5%
33.1°

ISO Diagrams

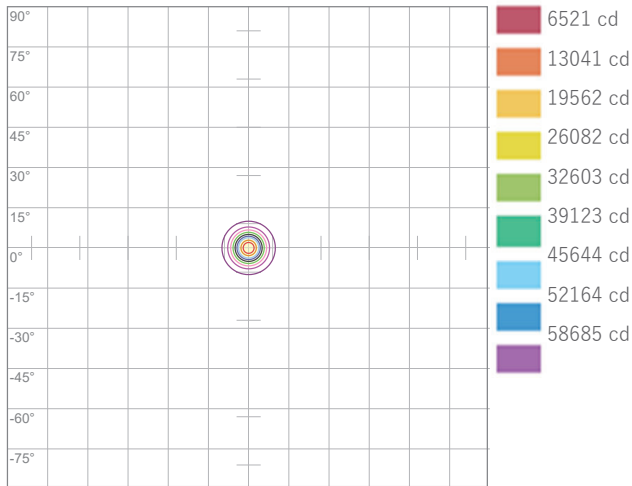

ISO Candela Diagram

Conditions:
Number of c-planes: 4
Candela at center: 65205 cd

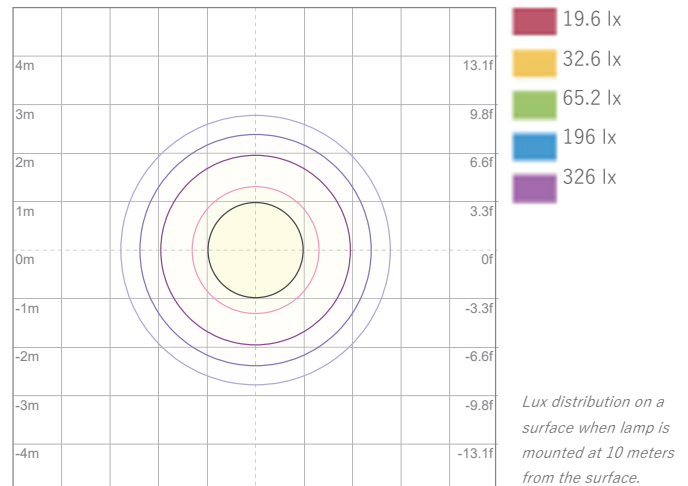

ISO LUX Diagram

Conditions:
Number of c-planes: 4
LUX at center: 652 lx

Lux distribution on a surface when lamp is mounted at 10 meters from the surface.

Linear Distribution

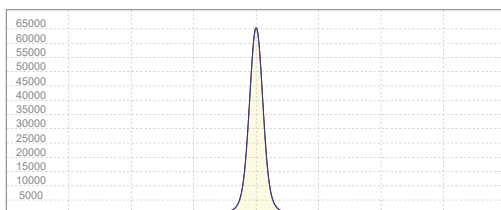

Peak Candela
65205 cd

Calculate Center Beam Intensities

$$\text{lux} = 65205 / \text{distance(m)}^2$$

$$\text{fc} = 65205 / \text{distance(ft)}^2$$

Key Measurements

Output

Total Lumen Output: 4207 lm

Peak Intensity: 65007 cd

Beam

Beam Angle (50%): 11.3°

Field Angle (10%): 22.2°

Cutoff Angle (2.5%): 33.3°

Color

Color Temperature: 8172 K

CRI: 89.8

TLCI: 90

TM30 R_F: 86.2

TM30 R_g: 102.3

Power Details

Efficacy: 27 Lumen/Watt

Power: 155.4 W

Supply Voltage: 119 V

Current: 1.31 A

Beam Details

Distance	3 m	5 m	10 m	15 m	20 m
Beam Width	0.6 m	1 m	2 m	3 m	3.9 m

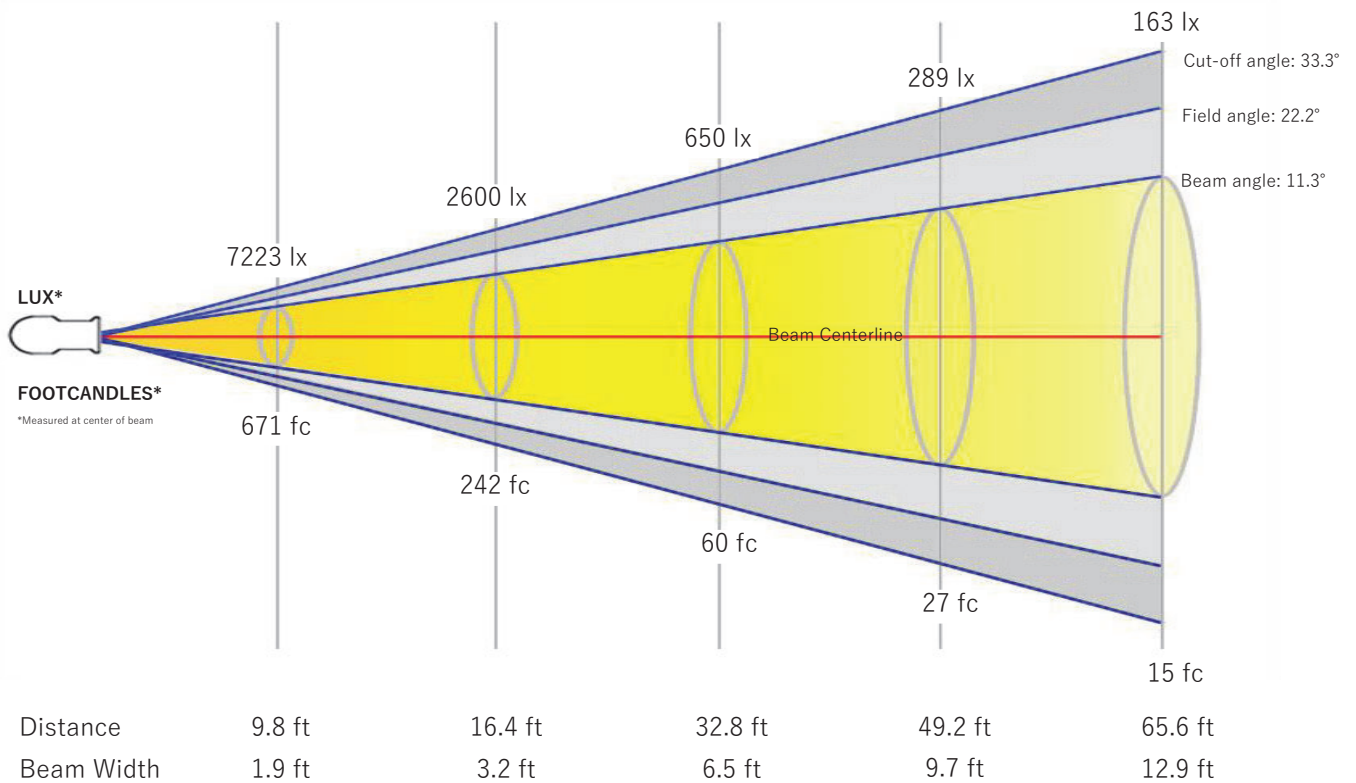

Beam Intensities from 1-20m

M	1	2	3	4	5	6	7	8	9	10	11	12	13	14	15	16	17	18	19	20
LX	65007	16252	7223	4063	2600	1806	1327	1016	803	650	537	451	385	332	289	254	225	201	180	163
FT	3.3	6.6	9.8	13.1	16.4	19.7	23	26.2	29.5	32.8	36.1	39.4	42.7	45.9	49.2	52.5	55.8	59.1	62.3	65.6
FC	6039.4	1509.8	671	377.5	241.6	167.8	123.3	94.4	74.6	60.4	49.9	41.9	35.7	30.8	26.8	23.6	20.9	18.6	16.7	15.1

Angular Distribution

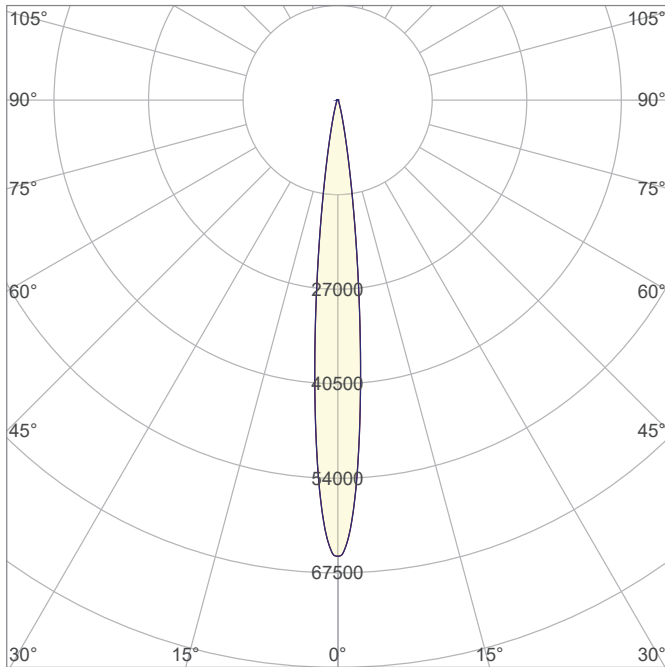

Beam Angle - 50%
11.3°
Field Angle - 10%
22.2°
Cutoff Angle - 2.5%
33.3°

ISO Diagrams

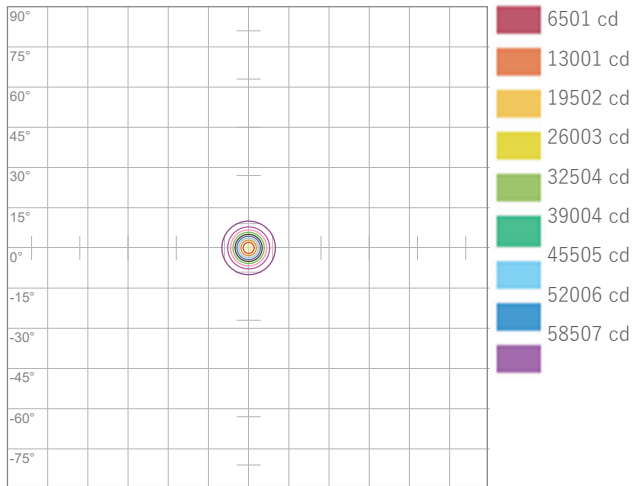

ISO Candela Diagram

Conditions:
Number of c-planes: 4
Candela at center: 65007 cd

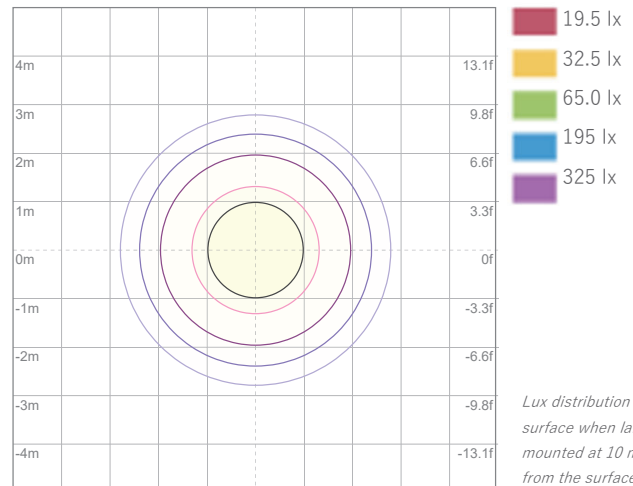

ISO LUX Diagram

Conditions:
Number of c-planes: 4
LUX at center: 650 lx

Lux distribution on a surface when lamp is mounted at 10 meters from the surface.

Linear Distribution

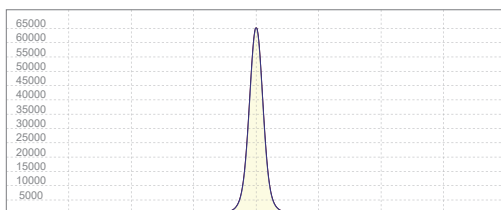

Peak Candela
65007 cd

Calculate Center Beam Intensities

$$\text{lux} = 65007 / \text{distance(m)}^2$$

$$\text{fc} = 65007 / \text{distance(ft)}^2$$

Key Measurements

Output

Total Lumen Output: 4448 lm
Peak Intensity: 25747 cd

Beam

Beam Angle (50%): 23°
Field Angle (10%): 33.3°
Cutoff Angle (2.5%): 45.1°

Color

Color Temperature: 5978 K
CRI: 88.8
TLCI: 90
TM30 R_F: 88.0
TM30 R_g: 107.3

Power Details

Efficacy: 29 Lumen/Watt
Power: 153.5 W
Supply Voltage: 119 V
Current: 1.29 A

Beam Details

Distance	3 m	5 m	10 m	15 m	20 m
Beam Width	1.2 m	2 m	4.1 m	6.1 m	8.2 m

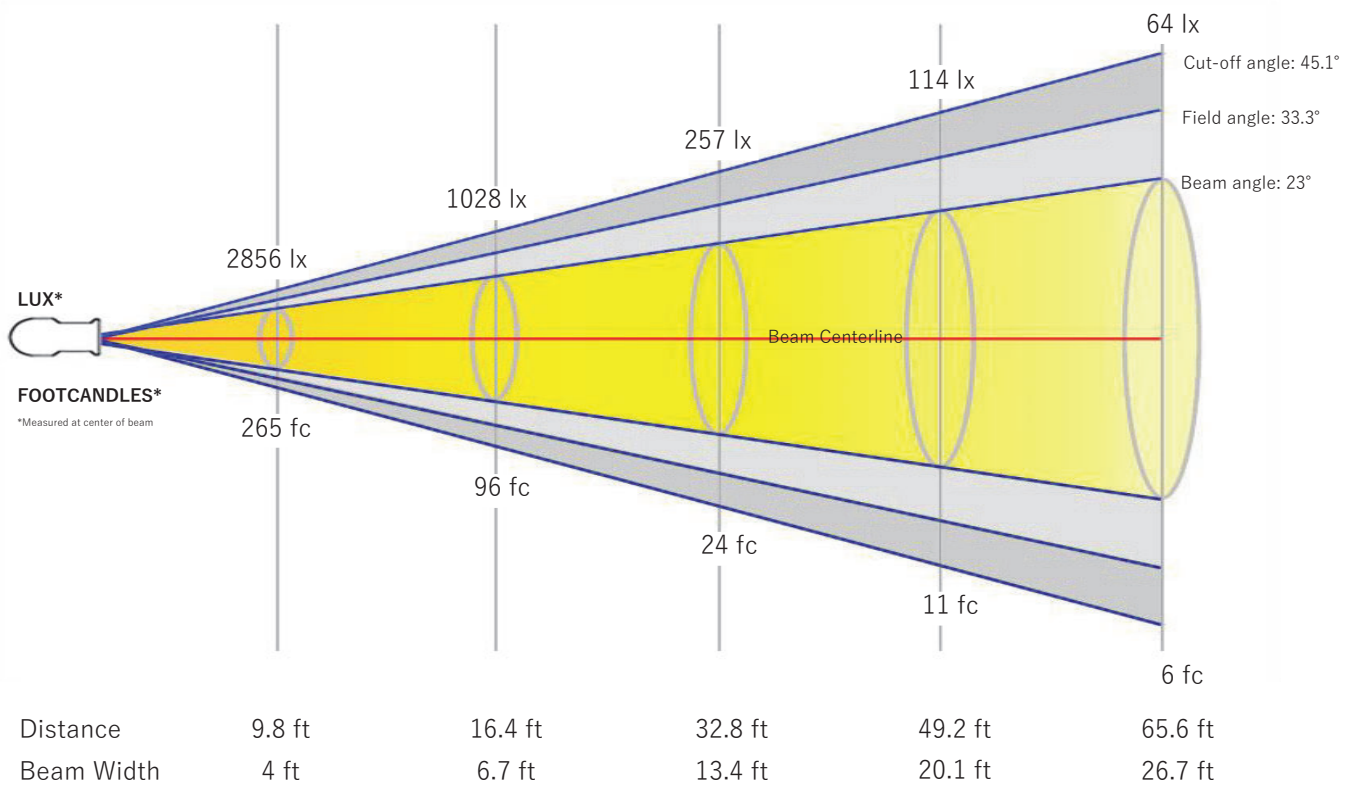

Beam Intensities from 1-20m

M	1	2	3	4	5	6	7	8	9	10	11	12	13	14	15	16	17	18	19	20
LX	25707	6427	2856	1607	1028	714	525	402	317	257	212	179	152	131	114	100	89	79	71	64
FT	3.3	6.6	9.8	13.1	16.4	19.7	23	26.2	29.5	32.8	36.1	39.4	42.7	45.9	49.2	52.5	55.8	59.1	62.3	65.6
FC	2388.3	597.1	265.4	149.3	95.5	66.3	48.7	37.3	29.5	23.9	19.7	16.6	14.1	12.2	10.6	9.3	8.3	7.4	6.6	6

Angular Distribution

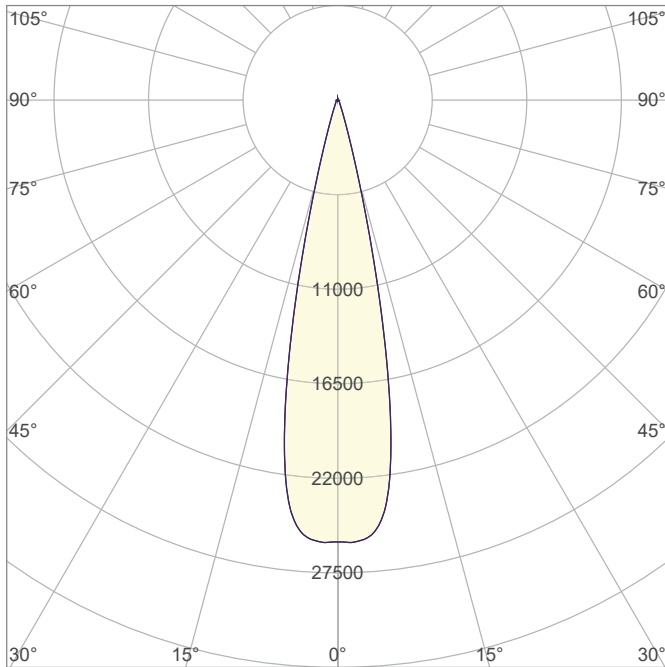

Beam Angle - 50%
23°
Field Angle - 10%
33.3°
Cutoff Angle - 2.5%
45.1°

ISO Diagrams

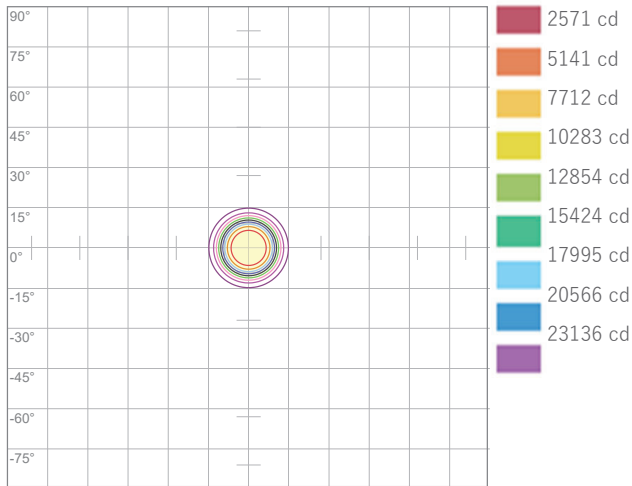

ISO Candela Diagram

Conditions:
Number of c-planes: 4
Candela at center: 25707 cd

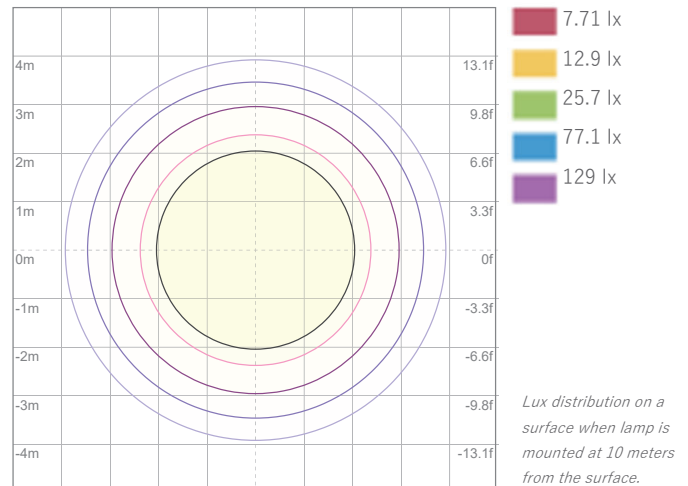

ISO LUX Diagram

Conditions:
Number of c-planes: 4
LUX at center: 257 lx

Lux distribution on a surface when lamp is mounted at 10 meters from the surface.

Linear Distribution

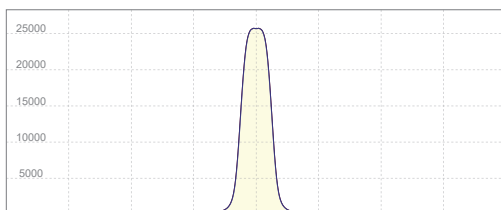

Peak Candela
25747 cd

Calculate Center Beam Intensities

$$\text{lux} = 25747 / \text{distance(m)}^2$$

$$\text{fc} = 25747 / \text{distance(ft)}^2$$

Key Measurements

Output

Total Lumen Output: 4722 lm
Peak Intensity: 27181 cd

Beam

Beam Angle (50%): 23.1°
Field Angle (10%): 33.3°
Cutoff Angle (2.5%): 45.1°

Color

Color Temperature: 3245 K
CRI: 90.2
TLCI: 92
TM30 R_F: 91.6
TM30 R_g: 106.7

Power Details

Efficacy: 31 Lumen/Watt
Power: 154.7 W
Supply Voltage: 118 V
Current: 1.31 A

Beam Details

Distance	3 m	5 m	10 m	15 m	20 m
Beam Width	1.2 m	2 m	4.1 m	6.1 m	8.2 m

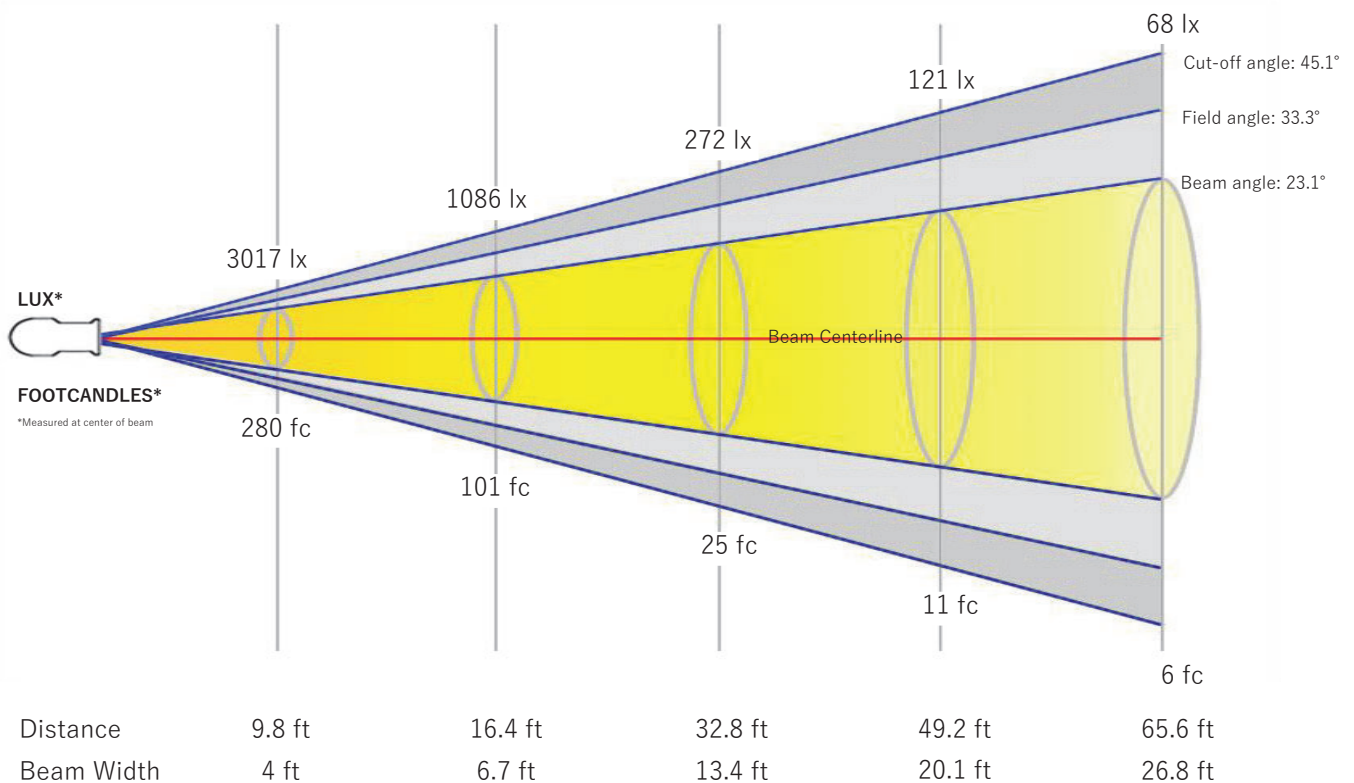

Beam Intensities from 1-20m

M	1	2	3	4	5	6	7	8	9	10	11	12	13	14	15	16	17	18	19	20
LX	27155	6789	3017	1697	1086	754	554	424	335	272	224	189	161	139	121	106	94	84	75	68
FT	3.3	6.6	9.8	13.1	16.4	19.7	23	26.2	29.5	32.8	36.1	39.4	42.7	45.9	49.2	52.5	55.8	59.1	62.3	65.6
FC	2522.8	630.7	280.3	157.7	100.9	70.1	51.5	39.4	31.1	25.2	20.8	17.5	14.9	12.9	11.2	9.9	8.7	7.8	7	6.3

Angular Distribution

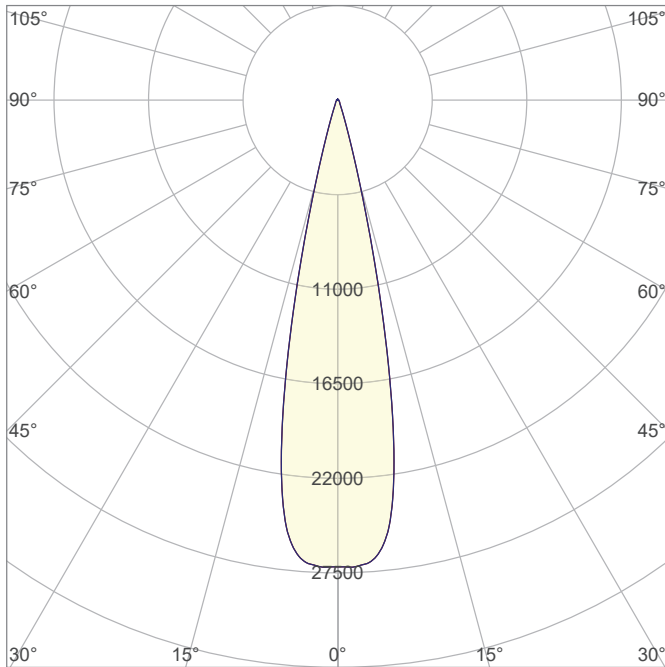

Beam Angle - 50%
23.1°
Field Angle - 10%
33.3°
Cutoff Angle - 2.5%
45.1°

ISO Diagrams

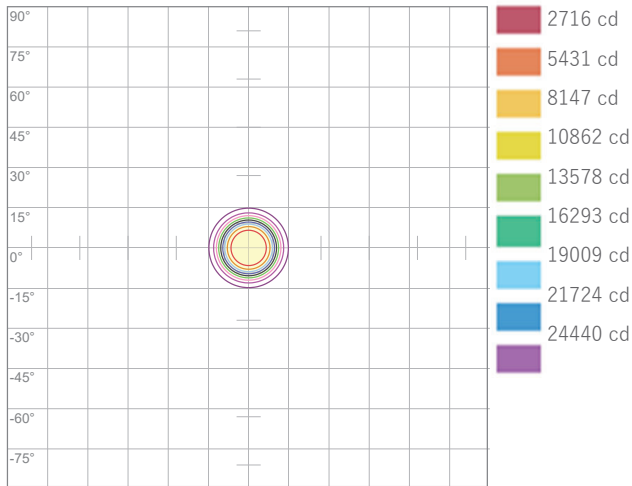

ISO Candela Diagram

Conditions:
Number of c-planes: 4
Candela at center: 27155 cd

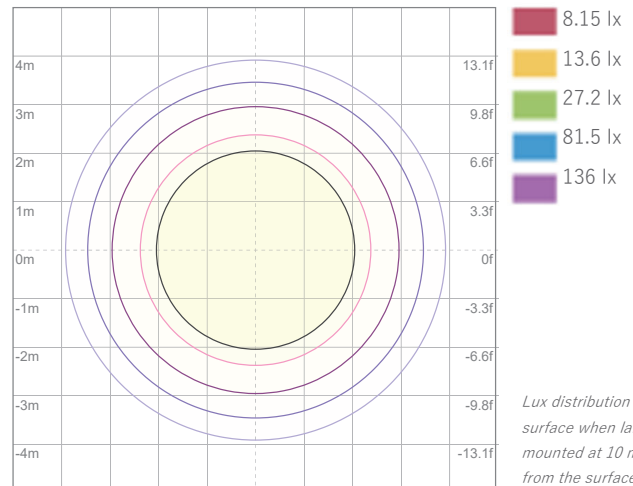

ISO LUX Diagram

Conditions:
Number of c-planes: 4
LUX at center: 272 lx

Lux distribution on a surface when lamp is mounted at 10 meters from the surface.

Linear Distribution

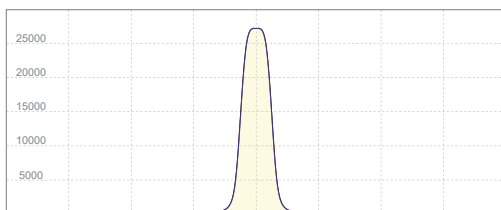

Peak Candela
27181 cd

Calculate Center Beam Intensities

$$\text{lux} = 27181 / \text{distance(m)}^2$$

$$\text{fc} = 27181 / \text{distance(ft)}^2$$

Key Measurements

Output

Total Lumen Output: 4546 lm
Peak Intensity: 26184 cd

Beam

Beam Angle (50%): 23°
Field Angle (10%): 33.4°
Cutoff Angle (2.5%): 45.2°

Color

Color Temperature: 4523 K
CRI: 86.2
TLCI: 87
TM30 R_F: 88.6
TM30 R_g: 109.5

Power Details

Efficacy: 30 Lumen/Watt
Power: 152.7 W
Supply Voltage: 118 V
Current: 1.29 A

Beam Details

Distance	3 m	5 m	10 m	15 m	20 m
Beam Width	1.2 m	2 m	4.1 m	6.1 m	8.2 m

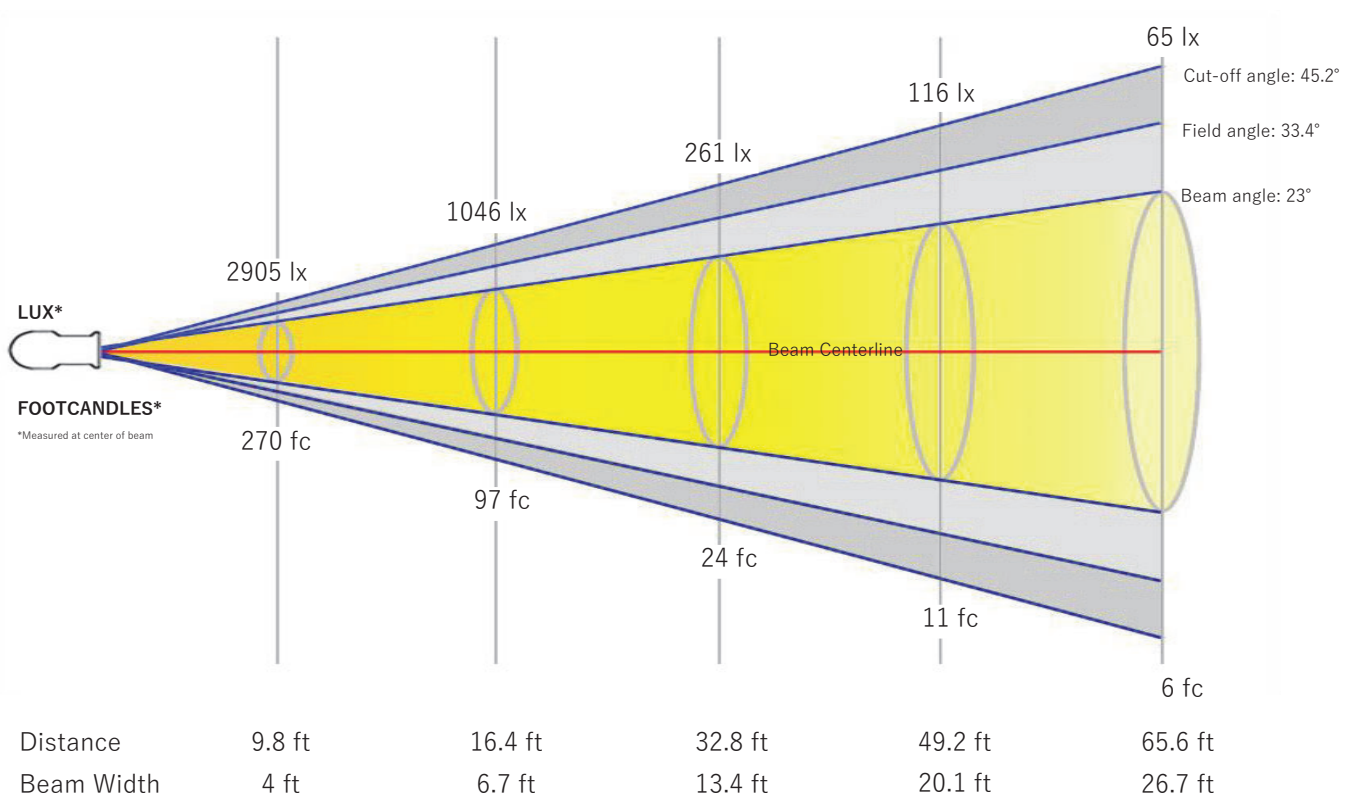

Beam Intensities from 1-20m

M	1	2	3	4	5	6	7	8	9	10	11	12	13	14	15	16	17	18	19	20
LX	26141	6535	2905	1634	1046	726	533	408	323	261	216	182	155	133	116	102	90	81	72	65
FT	3.3	6.6	9.8	13.1	16.4	19.7	23	26.2	29.5	32.8	36.1	39.4	42.7	45.9	49.2	52.5	55.8	59.1	62.3	65.6
FC	2428.6	607.2	269.8	151.8	97.1	67.5	49.6	37.9	30	24.3	20.1	16.9	14.4	12.4	10.8	9.5	8.4	7.5	6.7	6.1

Angular Distribution

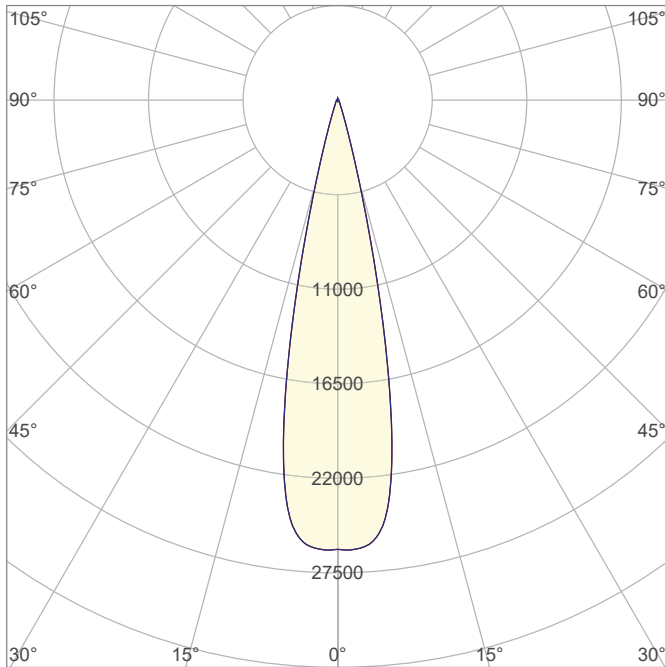

Beam Angle - 50%
23°
Field Angle - 10%
33.4°
Cutoff Angle - 2.5%
45.2°

ISO Diagrams

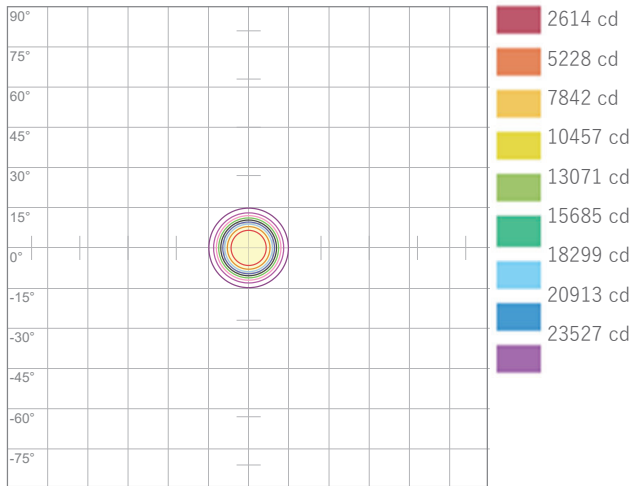

ISO Candela Diagram

Conditions:
Number of c-planes: 4
Candela at center: 26141 cd

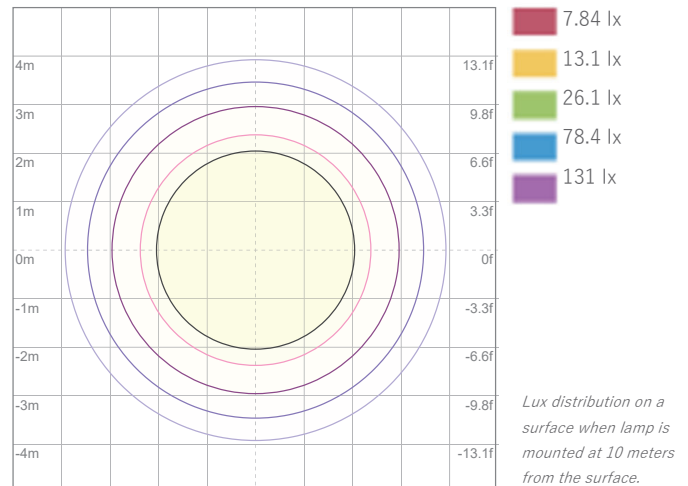

ISO LUX Diagram

Conditions:
Number of c-planes: 4
LUX at center: 261 lx

Lux distribution on a surface when lamp is mounted at 10 meters from the surface.

Linear Distribution

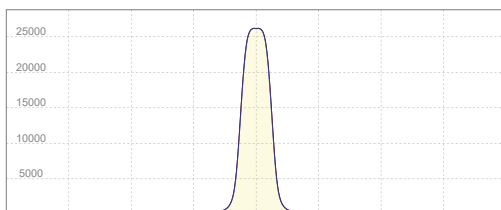

Peak Candela
26184 cd

Calculate Center Beam Intensities

$$\text{lux} = 26184 / \text{distance(m)}^2$$

$$\text{fc} = 26184 / \text{distance(ft)}^2$$

Key Measurements

Output

Total Lumen Output: 4439 lm

Peak Intensity: 25647 cd

Beam

Beam Angle (50%): 23.1°

Field Angle (10%): 33.3°

Cutoff Angle (2.5%): 45.2°

Color

Color Temperature: 6463 K

CRI: 89.6

TLCI: 91

TM30 R_F: 87.8

TM30 R_g: 106.3

Power Details

Efficacy: 29 Lumen/Watt

Power: 153.7 W

Supply Voltage: 118 V

Current: 1.30 A

Beam Details

Distance	3 m	5 m	10 m	15 m	20 m
Beam Width	1.2 m	2 m	4.1 m	6.1 m	8.2 m

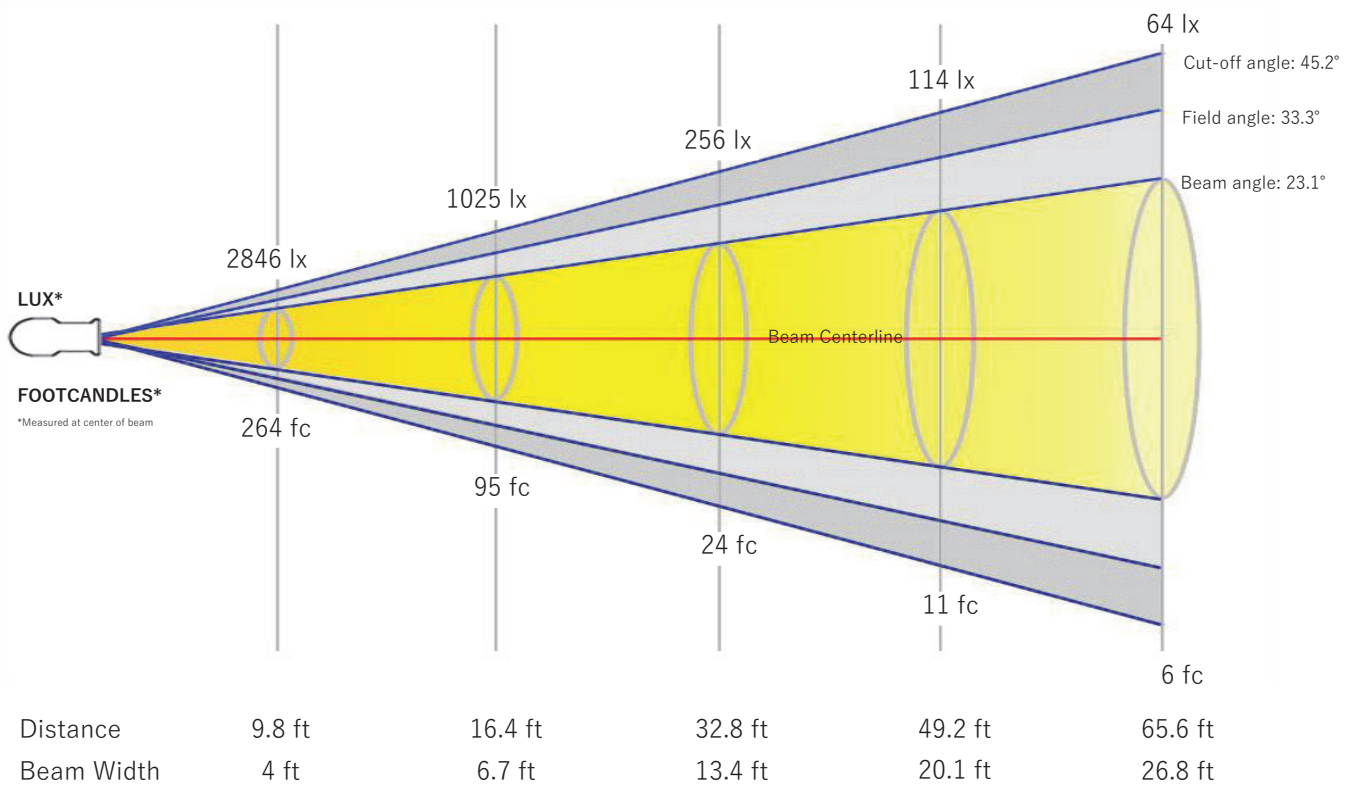

Beam Intensities from 1-20m

M	1	2	3	4	5	6	7	8	9	10	11	12	13	14	15	16	17	18	19	20
LX	25616	6404	2846	1601	1025	712	523	400	316	256	212	178	152	131	114	100	89	79	71	64
FT	3.3	6.6	9.8	13.1	16.4	19.7	23	26.2	29.5	32.8	36.1	39.4	42.7	45.9	49.2	52.5	55.8	59.1	62.3	65.6
FC	2379.8	595	264.4	148.7	95.2	66.1	48.6	37.2	29.4	23.8	19.7	16.5	14.1	12.1	10.6	9.3	8.2	7.3	6.6	5.9

Angular Distribution

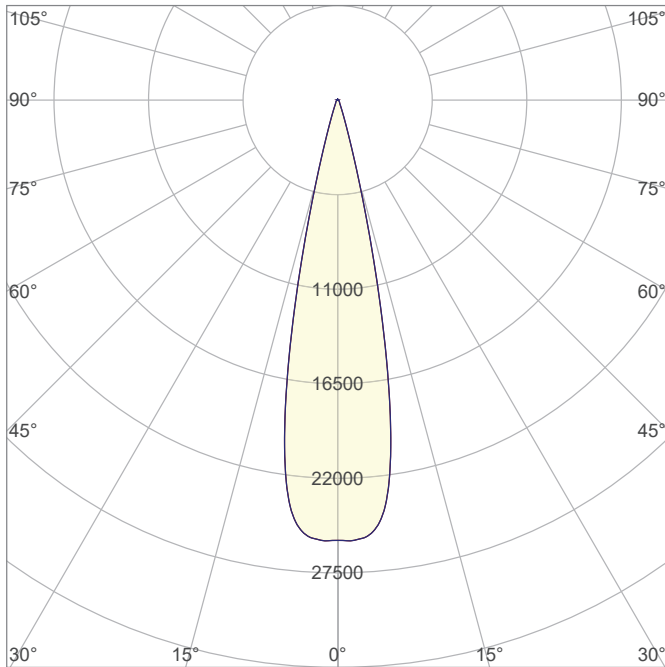

Beam Angle - 50%
23.1°
Field Angle - 10%
33.3°
Cutoff Angle - 2.5%
45.2°

ISO Diagrams

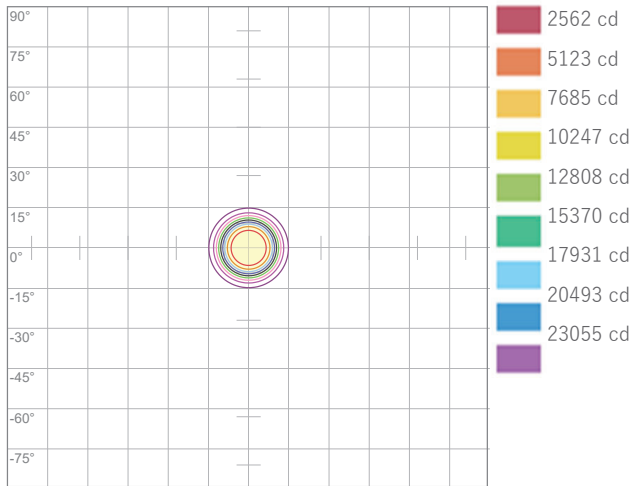

ISO Candela Diagram

Conditions:
Number of c-planes: 4
Candela at center: 25616 cd

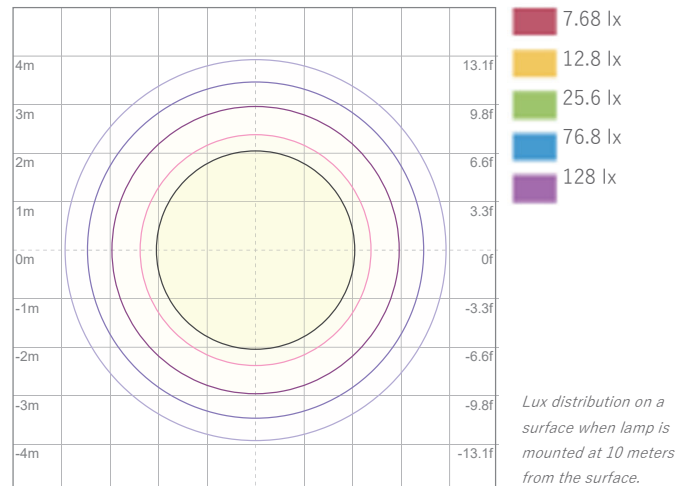

ISO LUX Diagram

Conditions:
Number of c-planes: 4
LUX at center: 256 lx

Lux distribution on a surface when lamp is mounted at 10 meters from the surface.

Linear Distribution

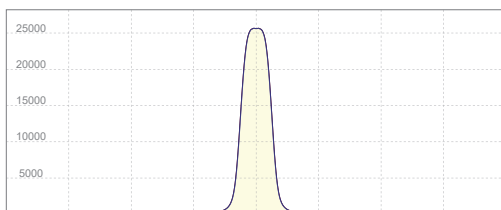

Peak Candela
25647 cd

Calculate Center Beam Intensities

$$\text{lux} = 25647 / \text{distance(m)}^2$$

$$\text{fc} = 25647 / \text{distance(ft)}^2$$

Key Measurements

Output

Total Lumen Output: 4374 lm

Peak Intensity: 25302 cd

Beam

Beam Angle (50%): 23.1°

Field Angle (10%): 33.4°

Cutoff Angle (2.5%): 45.3°

Color

Color Temperature: 8303 K

CRI: 89.7

TLCI: 90

TM30 R_F: 86.1

TM30 R_g: 102.2

Power Details

Efficacy: 28 Lumen/Watt

Power: 155.4 W

Supply Voltage: 119 V

Current: 1.31 A

Beam Details

Distance	3 m	5 m	10 m	15 m	20 m
Beam Width	1.2 m	2 m	4.1 m	6.1 m	8.2 m

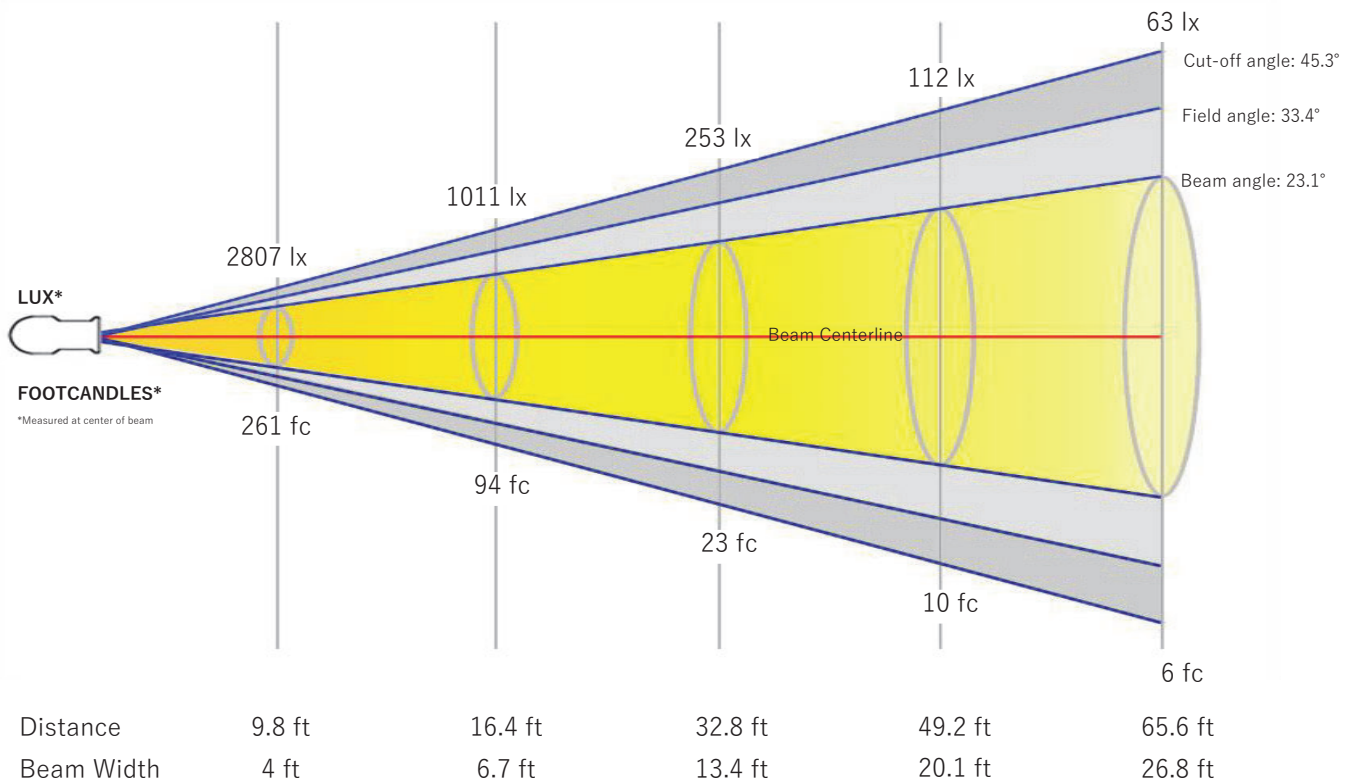

Beam Intensities from 1-20m

M	1	2	3	4	5	6	7	8	9	10	11	12	13	14	15	16	17	18	19	20
LX	25266	6317	2807	1579	1011	702	516	395	312	253	209	175	150	129	112	99	87	78	70	63
FT	3.3	6.6	9.8	13.1	16.4	19.7	23	26.2	29.5	32.8	36.1	39.4	42.7	45.9	49.2	52.5	55.8	59.1	62.3	65.6
FC	2347.3	586.8	260.8	146.7	93.9	65.2	47.9	36.7	29	23.5	19.4	16.3	13.9	12	10.4	9.2	8.1	7.2	6.5	5.9

Angular Distribution

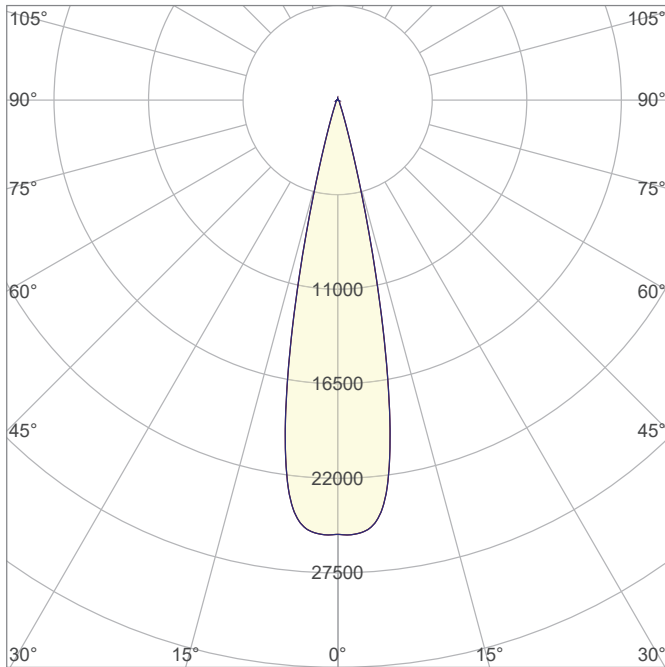

Beam Angle - 50%
23.1°
Field Angle - 10%
33.4°
Cutoff Angle - 2.5%
45.3°

ISO Diagrams

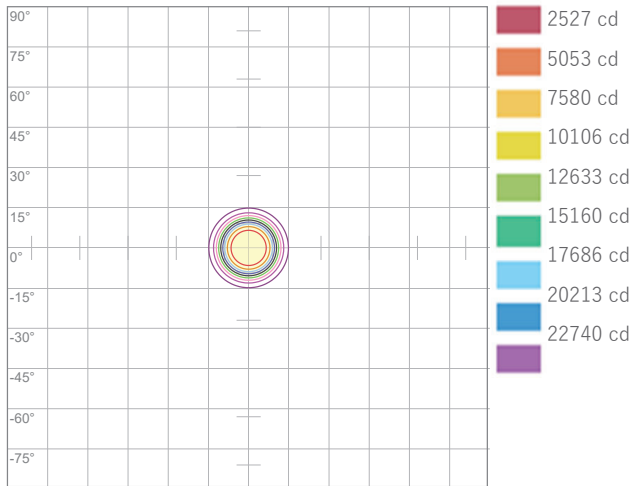

ISO Candela Diagram

Conditions:
Number of c-planes: 4
Candela at center: 25266 cd

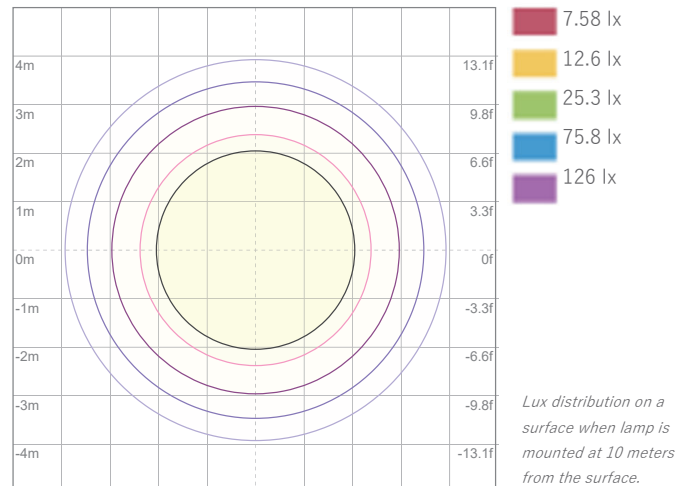

ISO LUX Diagram

Conditions:
Number of c-planes: 4
LUX at center: 253 lx

Lux distribution on a surface when lamp is mounted at 10 meters from the surface.

Linear Distribution

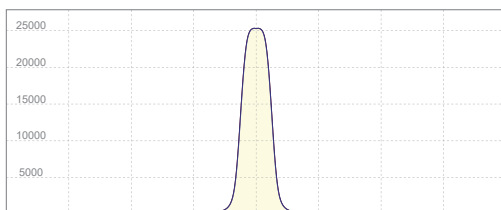

Peak Candela
25302 cd

Calculate Center Beam Intensities

$$\text{lux} = 25302 / \text{distance(m)}^2$$

$$\text{fc} = 25302 / \text{distance(ft)}^2$$

Key Measurements

Output

Total Lumen Output: 4431 lm
Peak Intensity: 22154 cd

Beam

Beam Angle (50%): 26.2°
Field Angle (10%): 36.9°
Cutoff Angle (2.5%): 43.7°

Color

Color Temperature: 6017 K
CRI: 88.8
TLCI: 90
TM30 R_F: 87.9
TM30 R_g: 107.3

Power Details

Efficacy: 29 Lumen/Watt
Power: 152.3 W
Supply Voltage: 119 V
Current: 1.28 A

Beam Details

Distance	3 m	5 m	10 m	15 m	20 m
Beam Width	1.4 m	2.3 m	4.7 m	7 m	9.3 m

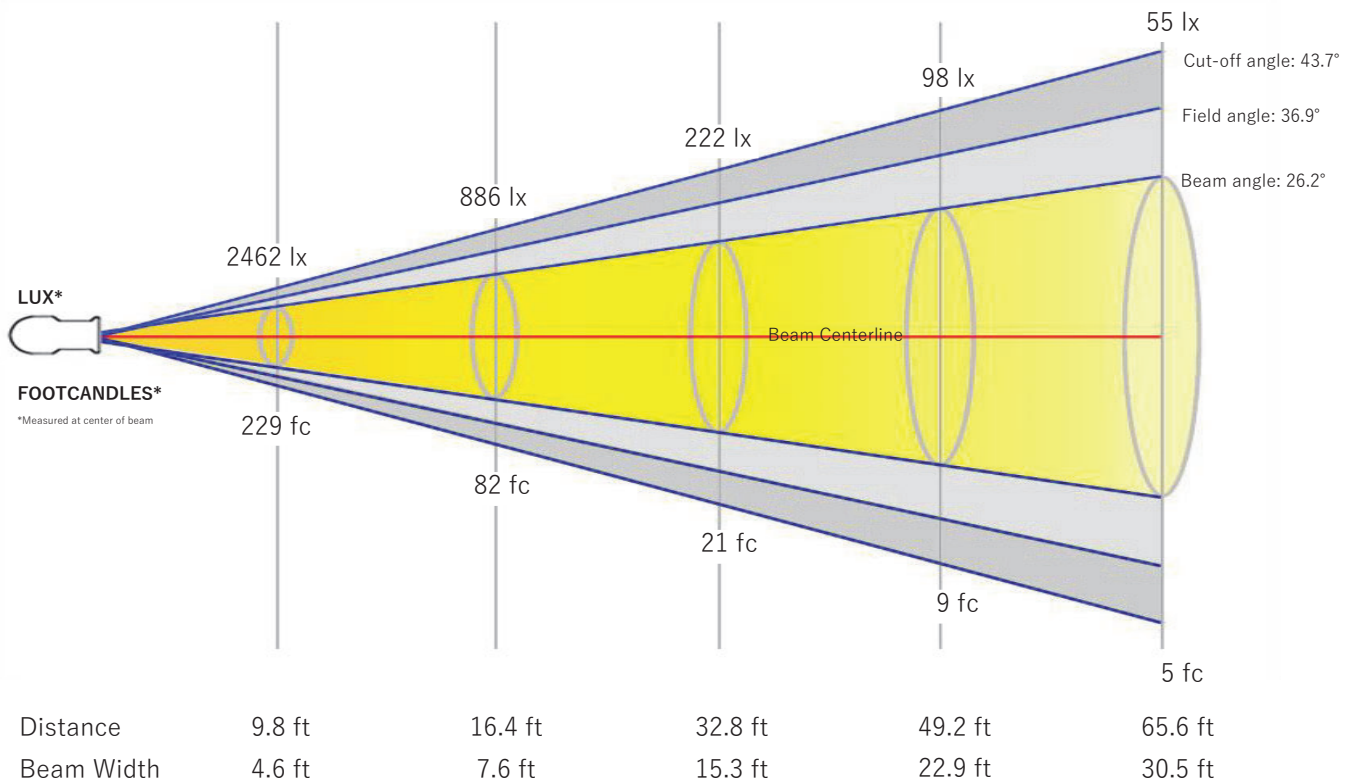

Beam Intensities from 1-20m

M	1	2	3	4	5	6	7	8	9	10	11	12	13	14	15	16	17	18	19	20
LX	22154	5538	2462	1385	886	615	452	346	274	222	183	154	131	113	98	87	77	68	61	55
FT	3.3	6.6	9.8	13.1	16.4	19.7	23	26.2	29.5	32.8	36.1	39.4	42.7	45.9	49.2	52.5	55.8	59.1	62.3	65.6
FC	2058.1	514.5	228.7	128.6	82.3	57.2	42	32.2	25.4	20.6	17	14.3	12.2	10.5	9.1	8	7.1	6.4	5.7	5.1

Angular Distribution

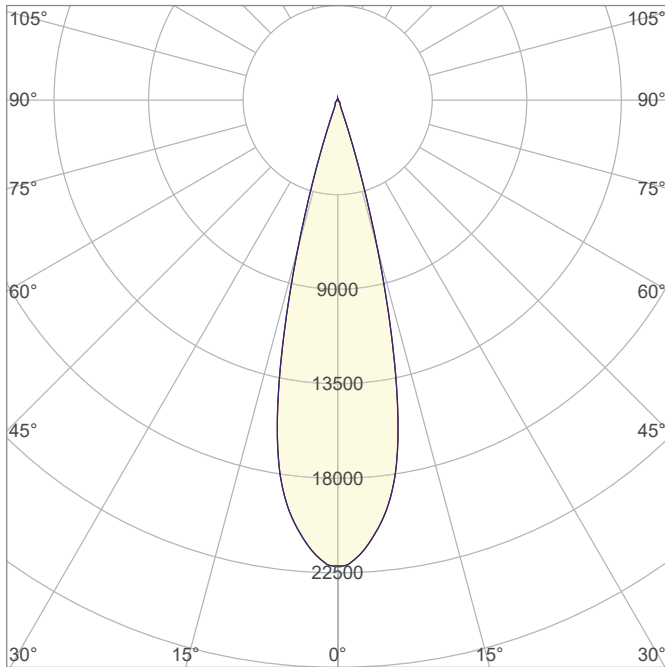

Beam Angle - 50%
26.2°
Field Angle - 10%
36.9°
Cutoff Angle - 2.5%
43.7°

ISO Diagrams

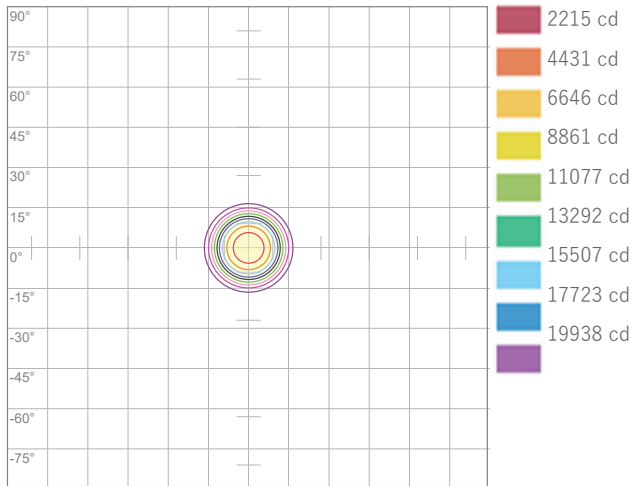

ISO Candela Diagram

Conditions:
Number of c-planes: 4
Candela at center: 22154 cd

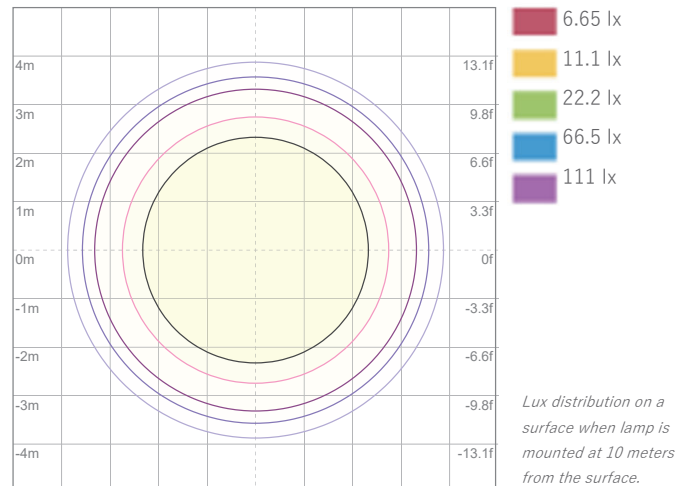

ISO LUX Diagram

Conditions:
Number of c-planes: 4
LUX at center: 222 lx

Linear Distribution

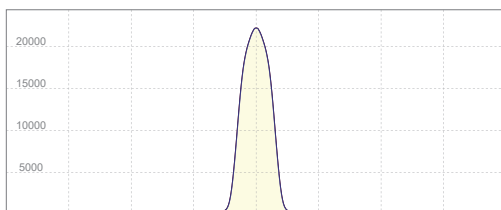

Peak Candela
22154 cd

Calculate Center Beam Intensities

$$\text{lux} = 22154 / \text{distance(m)}^2$$

$$\text{fc} = 22154 / \text{distance(ft)}^2$$

Key Measurements

Output

Total Lumen Output: 3904 lm

Peak Intensity: 19436 cd

Beam

Beam Angle (50%): 26.2°

Field Angle (10%): 37°

Cutoff Angle (2.5%): 43.6°

Color

Color Temperature: 2473 K

CRI: 89.5

TLCI: 92

TM30 R_F: 92.9

TM30 R_g: 105.6

Power Details

Efficacy: 28 Lumen/Watt

Power: 140 W

Supply Voltage: 120 V

Current: 1.17 A

Beam Details

Distance	3 m	5 m	10 m	15 m	20 m
Beam Width	1.4 m	2.3 m	4.6 m	7 m	9.3 m

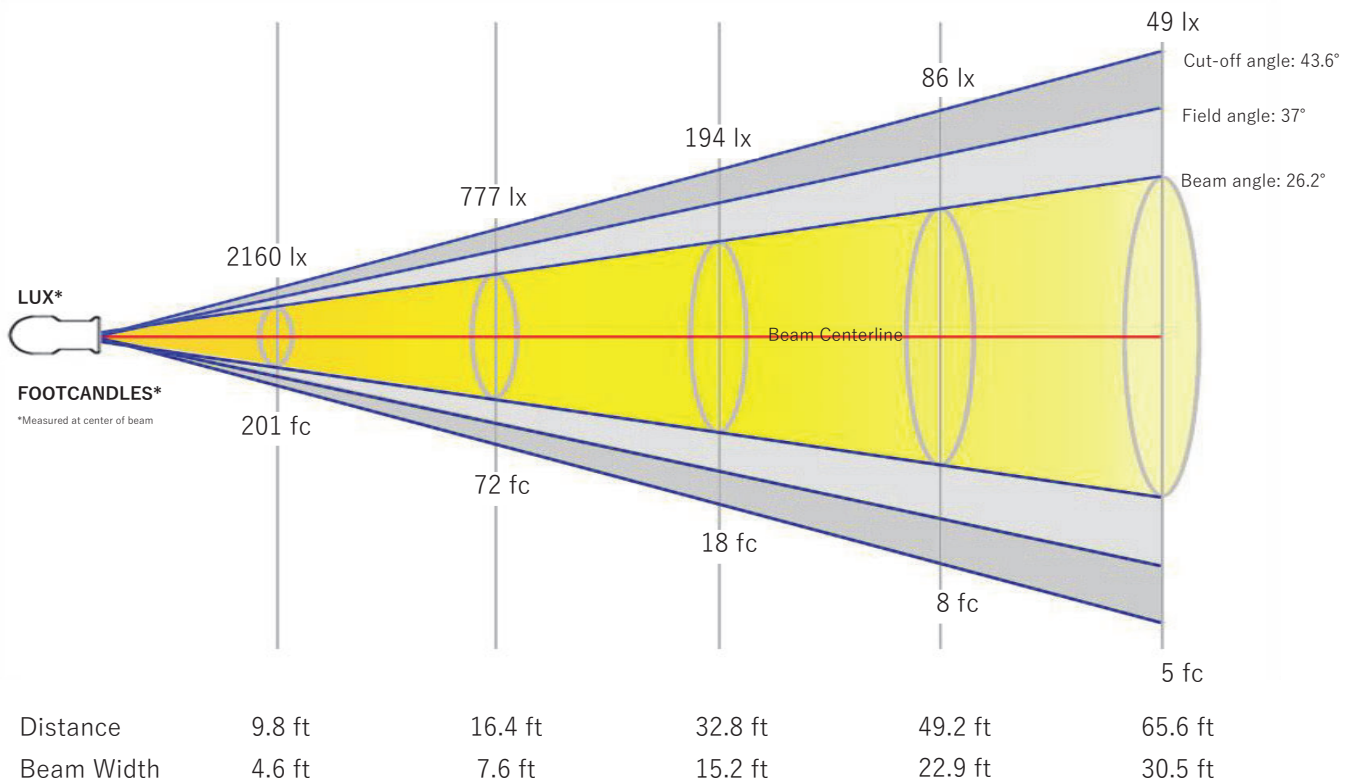

Beam Intensities from 1-20m

M	1	2	3	4	5	6	7	8	9	10	11	12	13	14	15	16	17	18	19	20
LX	19436	4859	2160	1215	777	540	397	304	240	194	161	135	115	99	86	76	67	60	54	49
FT	3.3	6.6	9.8	13.1	16.4	19.7	23	26.2	29.5	32.8	36.1	39.4	42.7	45.9	49.2	52.5	55.8	59.1	62.3	65.6
FC	1805.7	451.4	200.6	112.9	72.2	50.2	36.9	28.2	22.3	18.1	14.9	12.5	10.7	9.2	8	7.1	6.2	5.6	5	4.5

Angular Distribution

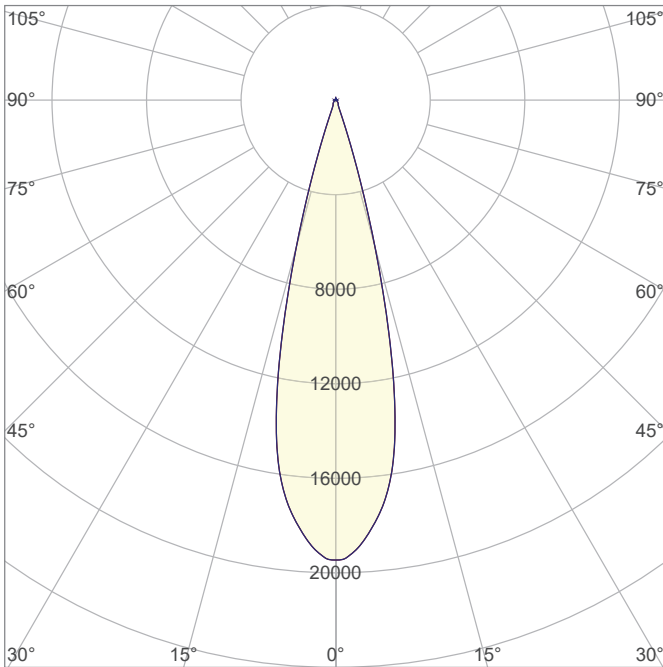

Beam Angle - 50%
26.2°
Field Angle - 10%
37°
Cutoff Angle - 2.5%
43.6°

ISO Diagrams

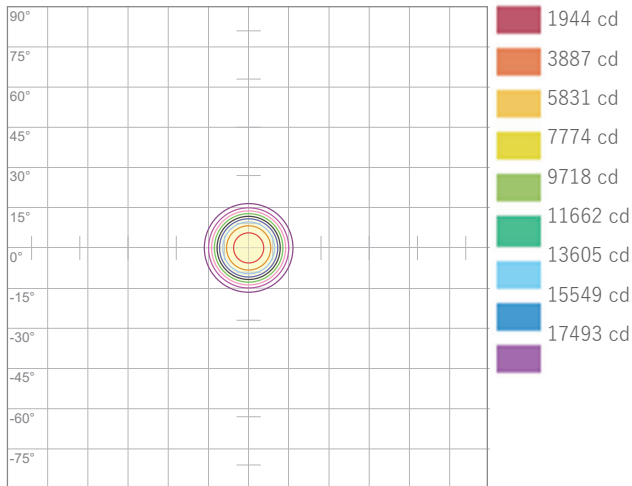

ISO Candela Diagram

Conditions:
Number of c-planes: 4
Candela at center: 19436 cd

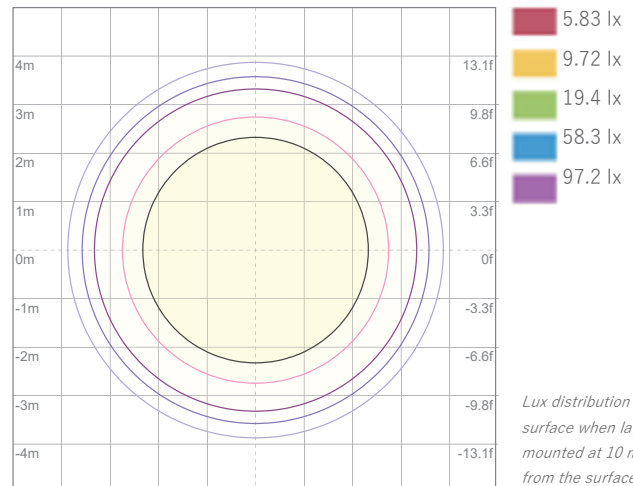

ISO LUX Diagram

Conditions:
Number of c-planes: 4
LUX at center: 194 lx

Lux distribution on a surface when lamp is mounted at 10 meters from the surface.

Linear Distribution

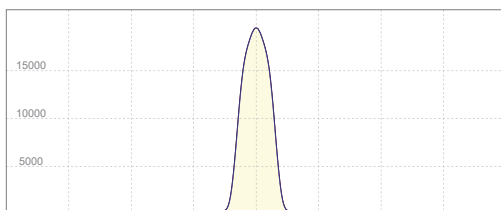

Peak Candela
19436 cd

Calculate Center Beam Intensities

$$\text{lux} = 19436 / \text{distance(m)}^2$$

$$\text{fc} = 19436 / \text{distance(ft)}^2$$

Key Measurements

Output

Total Lumen Output: 4631 lm

Peak Intensity: 23115 cd

Beam

Beam Angle (50%): 26.2°

Field Angle (10%): 36.9°

Cutoff Angle (2.5%): 43.6°

Color

Color Temperature: 3256 K

CRI: 90.3

TLCI: 92

TM30 R_F: 91.6

TM30 R_g: 106.7

Power Details

Efficacy: 30 Lumen/Watt

Power: 155.1 W

Supply Voltage: 120 V

Current: 1.29 A

Beam Details

Distance	3 m	5 m	10 m	15 m	20 m
Beam Width	1.4 m	2.3 m	4.7 m	7 m	9.3 m

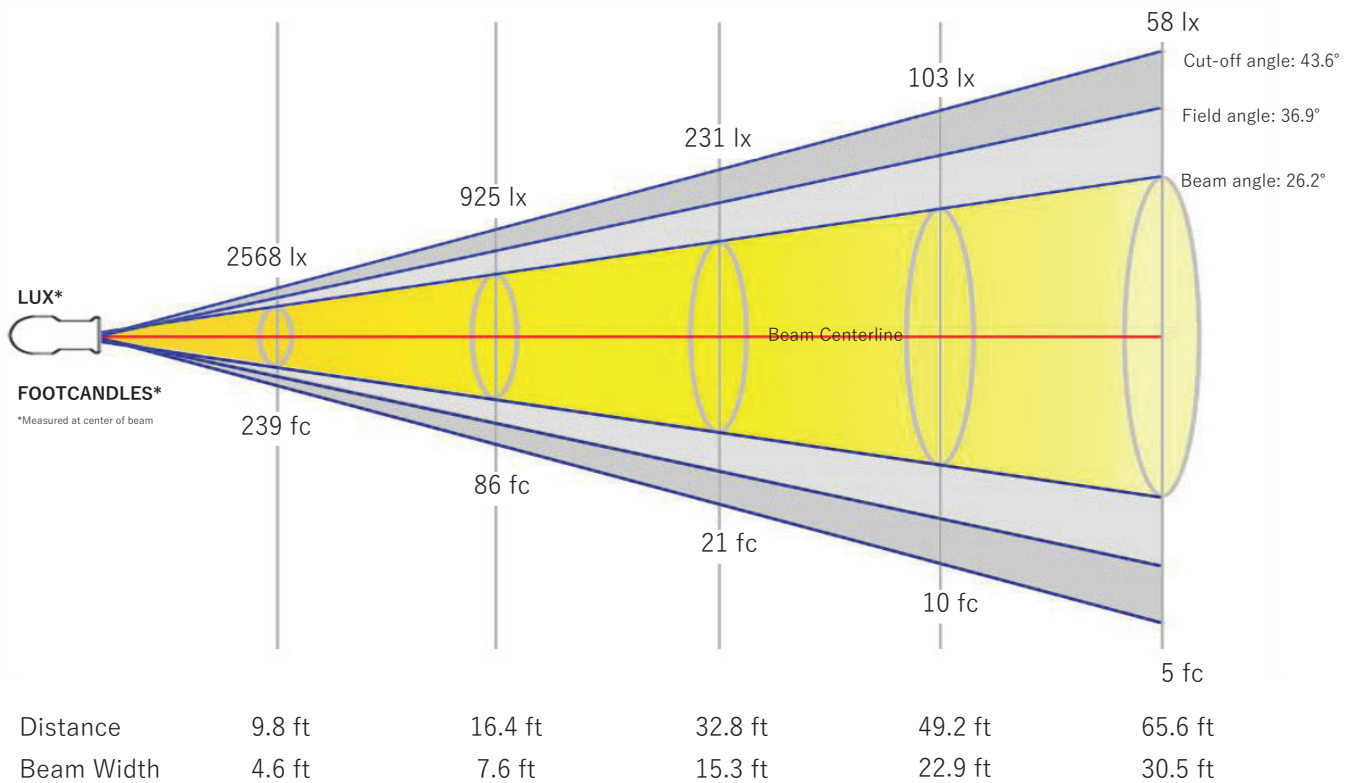

Beam Intensities from 1-20m

M	1	2	3	4	5	6	7	8	9	10	11	12	13	14	15	16	17	18	19	20
LX	23115	5779	2568	1445	925	642	472	361	285	231	191	161	137	118	103	90	80	71	64	58
FT	3.3	6.6	9.8	13.1	16.4	19.7	23	26.2	29.5	32.8	36.1	39.4	42.7	45.9	49.2	52.5	55.8	59.1	62.3	65.6
FC	2147.5	536.9	238.6	134.2	85.9	59.7	43.8	33.6	26.5	21.5	17.7	14.9	12.7	11	9.5	8.4	7.4	6.6	5.9	5.4

Angular Distribution

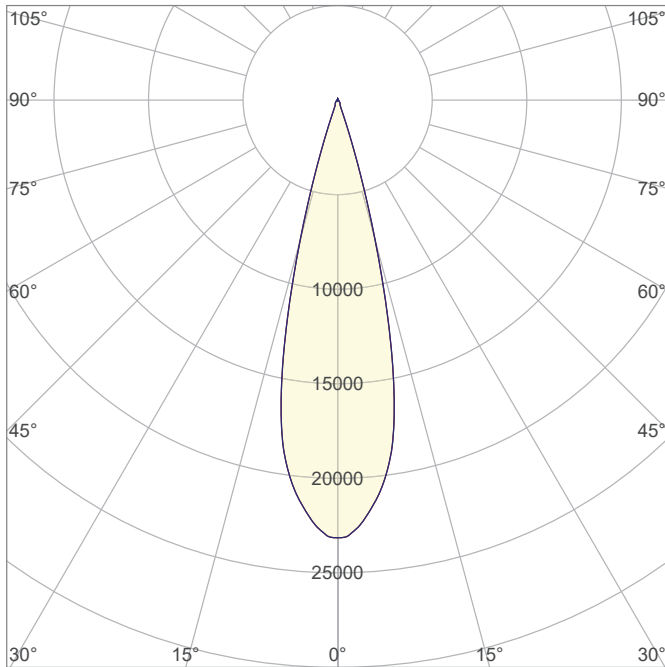

Beam Angle - 50%
26.2°
Field Angle - 10%
36.9°
Cutoff Angle - 2.5%
43.6°

ISO Diagrams

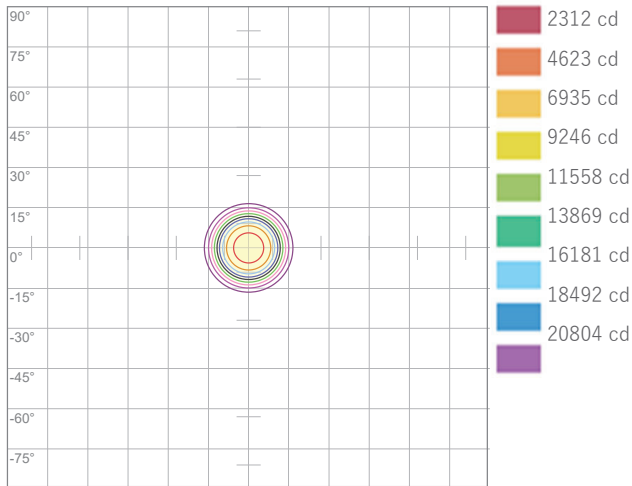

ISO Candela Diagram

Conditions:
Number of c-planes: 4
Candela at center: 23115 cd

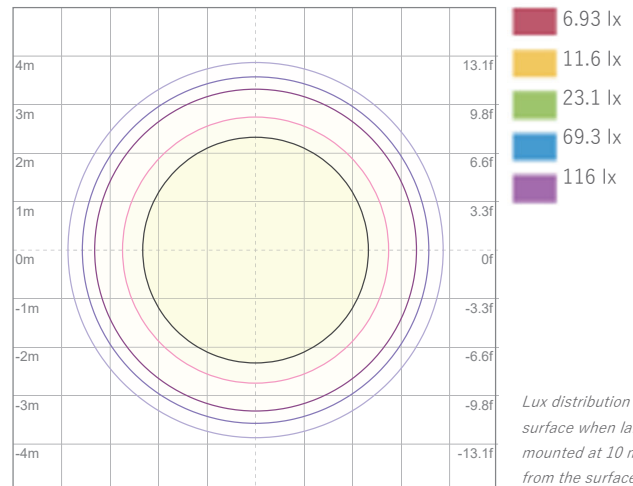

ISO LUX Diagram

Conditions:
Number of c-planes: 4
LUX at center: 231 lx

Lux distribution on a surface when lamp is mounted at 10 meters from the surface.

Linear Distribution

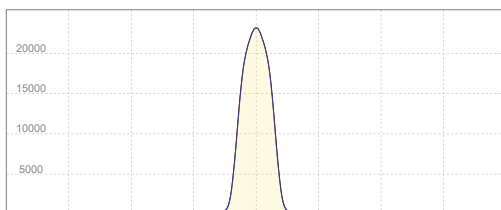

Peak Candela
23115 cd

Calculate Center Beam Intensities

$$\text{lux} = 23115 / \text{distance(m)}^2$$

$$\text{fc} = 23115 / \text{distance(ft)}^2$$

Key Measurements

Output

Total Lumen Output: 4484 lm

Peak Intensity: 22286 cd

Beam

Beam Angle (50%): 26.2°

Field Angle (10%): 37°

Cutoff Angle (2.5%): 43.8°

Color

Color Temperature: 4546 K

CRI: 86.3

TLCI: 87

TM30 R_F: 88.6

TM30 R_g: 109.4

Power Details

Efficacy: 38 Lumen/Watt

Power: 119 W

Supply Voltage: 120 V

Current: 0.992 A

Beam Details

Distance	3 m	5 m	10 m	15 m	20 m
Beam Width	1.4 m	2.3 m	4.7 m	7 m	9.3 m

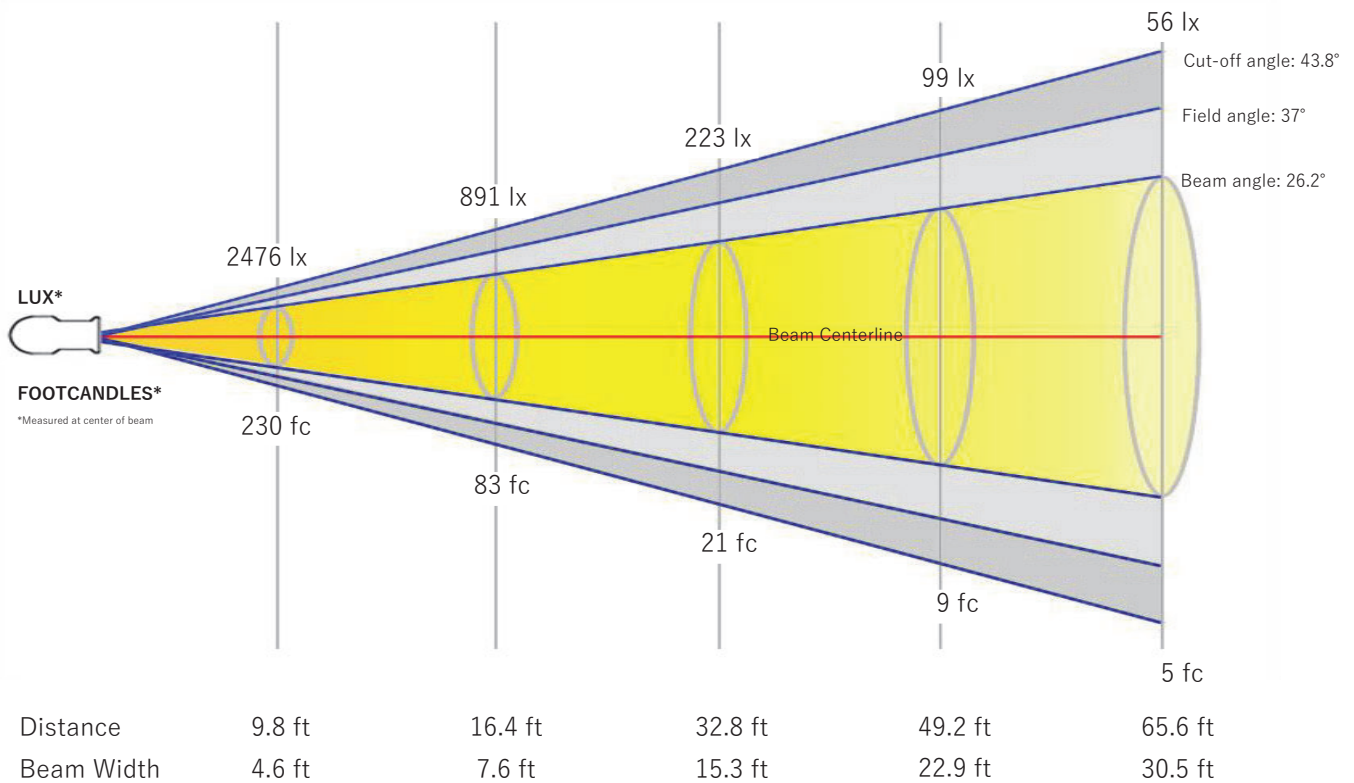

Beam Intensities from 1-20m

M	1	2	3	4	5	6	7	8	9	10	11	12	13	14	15	16	17	18	19	20
LX	22286	5572	2476	1393	891	619	455	348	275	223	184	155	132	114	99	87	77	69	62	56
FT	3.3	6.6	9.8	13.1	16.4	19.7	23	26.2	29.5	32.8	36.1	39.4	42.7	45.9	49.2	52.5	55.8	59.1	62.3	65.6
FC	2070.5	517.6	230.1	129.4	82.8	57.5	42.3	32.4	25.6	20.7	17.1	14.4	12.3	10.6	9.2	8.1	7.2	6.4	5.7	5.2

Angular Distribution

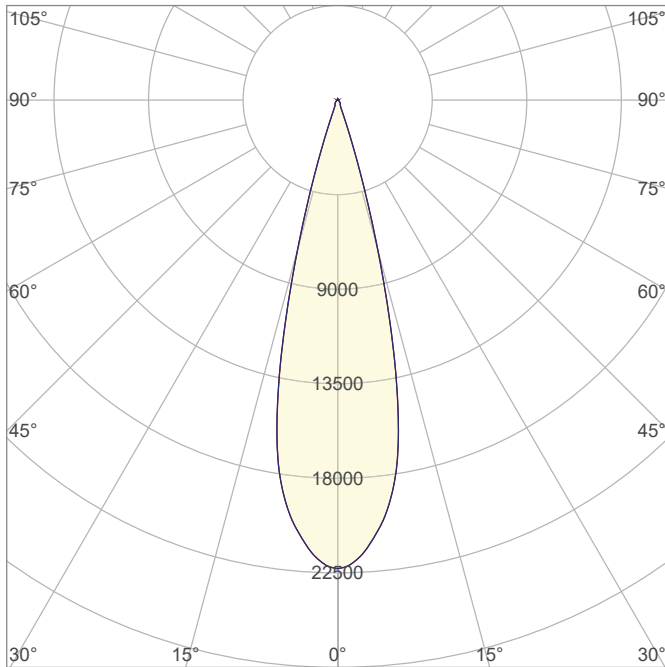

Beam Angle - 50%
26.2°
Field Angle - 10%
37°
Cutoff Angle - 2.5%
43.8°

ISO Diagrams

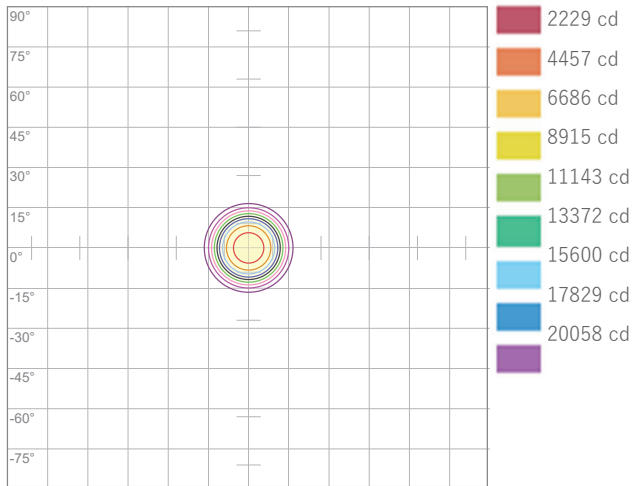

ISO Candela Diagram

Conditions:
Number of c-planes: 4
Candela at center: 22286 cd

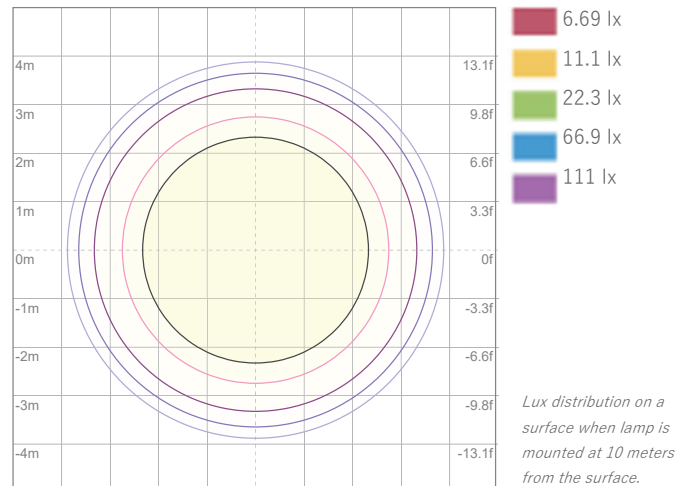

ISO LUX Diagram

Conditions:
Number of c-planes: 4
LUX at center: 223 lx

Linear Distribution

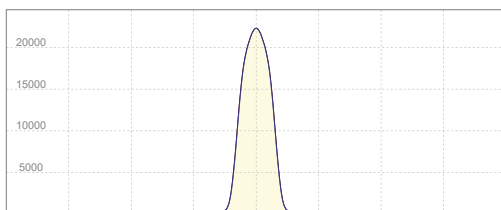

Peak Candela
22286 cd

Calculate Center Beam Intensities

$$\text{lux} = 22286 / \text{distance(m)}^2$$

$$\text{fc} = 22286 / \text{distance(ft)}^2$$

Key Measurements

Output

Total Lumen Output: 4402 lm

Peak Intensity: 21966 cd

Beam

Beam Angle (50%): 26.2°

Field Angle (10%): 36.9°

Cutoff Angle (2.5%): 43.7°

Color

Color Temperature: 5627 K

CRI: 87.8

TLCI: 89

TM30 R_F: 88.0

TM30 R_g: 108.2

Power Details

Efficacy: 29 Lumen/Watt

Power: 153.3 W

Supply Voltage: 120 V

Current: 1.28 A

Beam Details

Distance	3 m	5 m	10 m	15 m	20 m
Beam Width	1.4 m	2.3 m	4.7 m	7 m	9.3 m

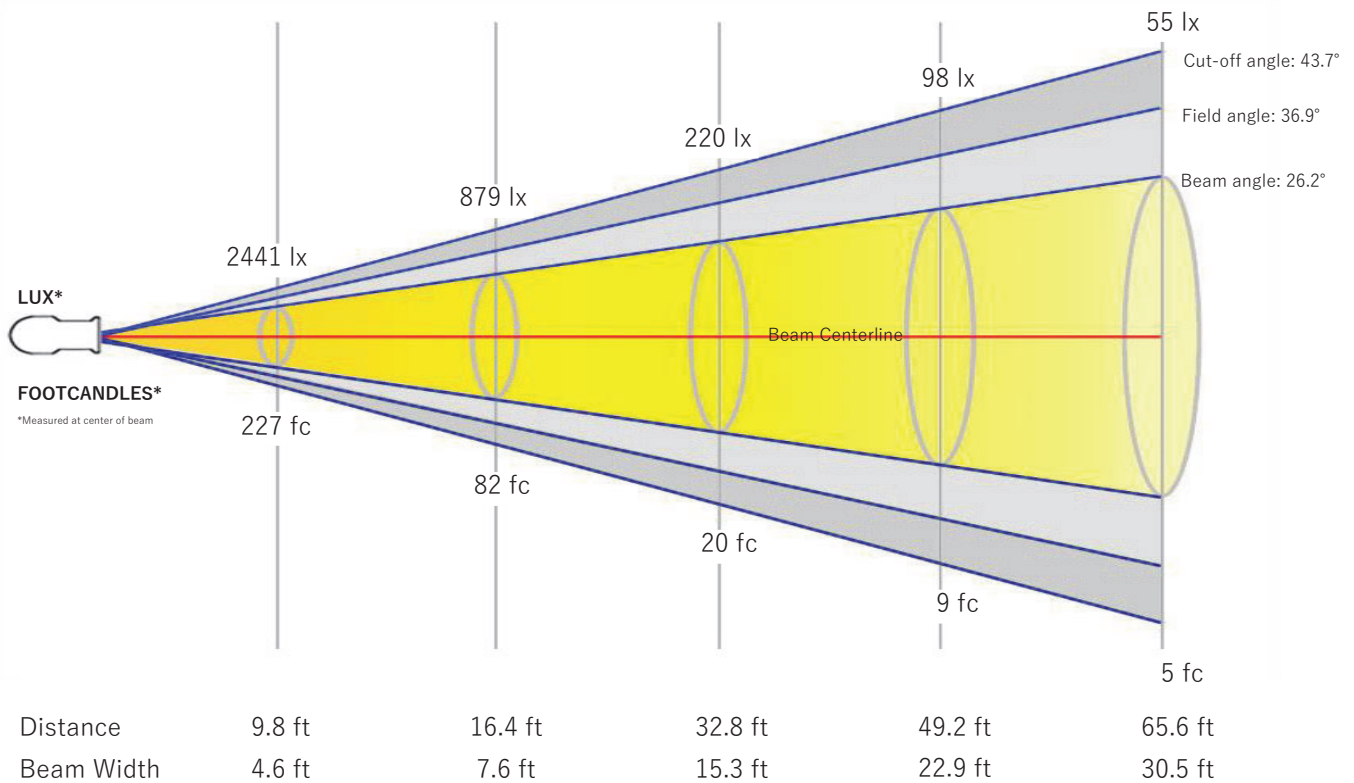

Beam Intensities from 1-20m

M	1	2	3	4	5	6	7	8	9	10	11	12	13	14	15	16	17	18	19	20
LX	21966	5491	2441	1373	879	610	448	343	271	220	182	153	130	112	98	86	76	68	61	55
FT	3.3	6.6	9.8	13.1	16.4	19.7	23	26.2	29.5	32.8	36.1	39.4	42.7	45.9	49.2	52.5	55.8	59.1	62.3	65.6
FC	2040.7	510.2	226.7	127.5	81.6	56.7	41.6	31.9	25.2	20.4	16.9	14.2	12.1	10.4	9.1	8	7.1	6.3	5.7	5.1

Angular Distribution

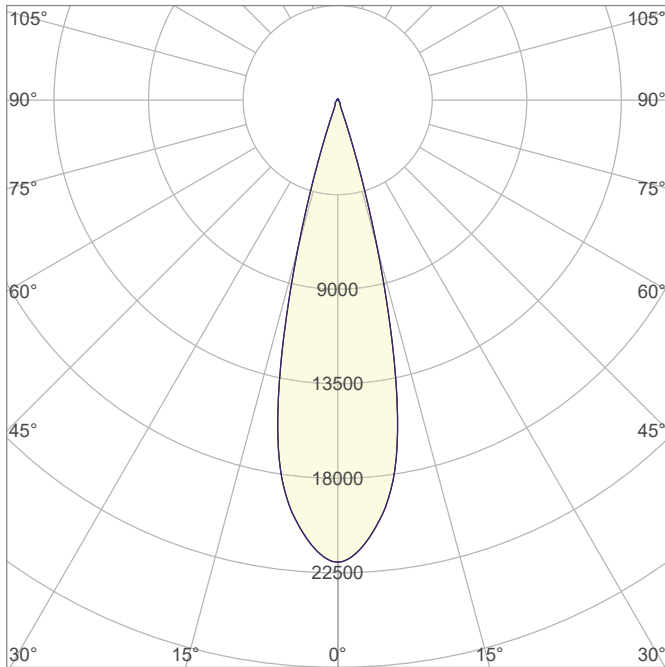

Beam Angle - 50%
26.2°
Field Angle - 10%
36.9°
Cutoff Angle - 2.5%
43.7°

ISO Diagrams

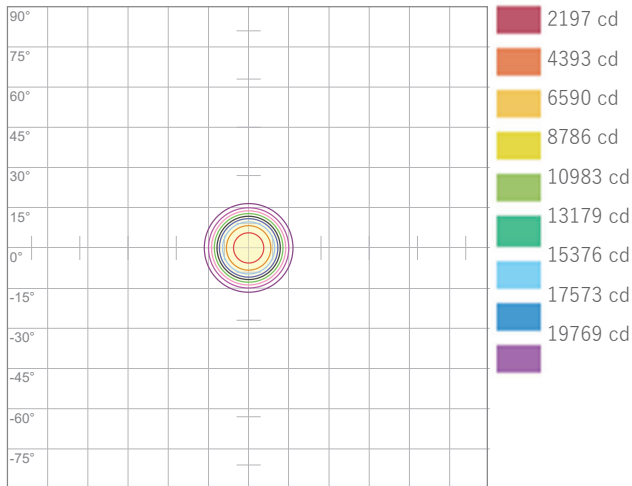

ISO Candela Diagram

Conditions:
Number of c-planes: 4
Candela at center: 21966 cd

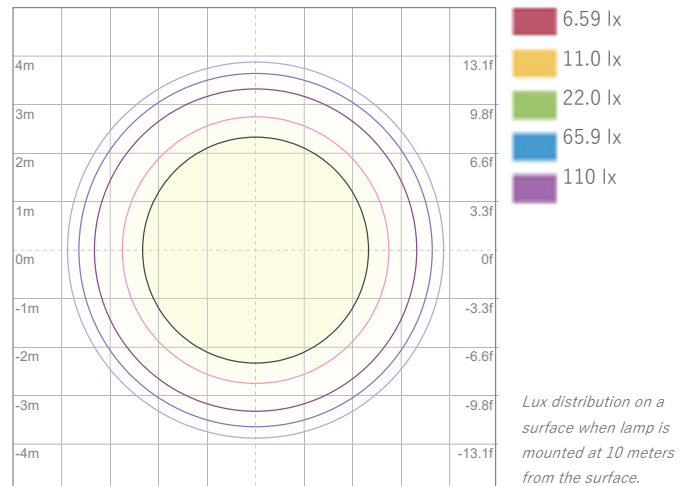

ISO LUX Diagram

Conditions:
Number of c-planes: 4
LUX at center: 220 lx

Linear Distribution

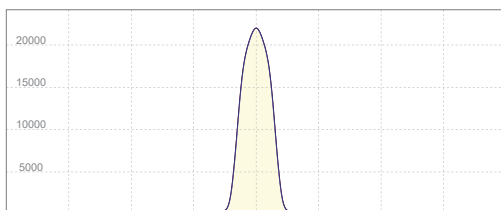

Peak Candela
21966 cd

Calculate Center Beam Intensities

$$\text{lux} = 21966 / \text{distance(m)}^2$$

$$\text{fc} = 21966 / \text{distance(ft)}^2$$

Key Measurements

Output

Total Lumen Output: 4394 lm
Peak Intensity: 21903 cd

Beam

Beam Angle (50%): 26.2°
Field Angle (10%): 37°
Cutoff Angle (2.5%): 43.7°

Color

Color Temperature: 6027 K
CRI: 88.9
TLCI: 90
TM30 R_F: 88.0
TM30 R_g: 107.3

Power Details

Efficacy: 37 Lumen/Watt
Power: 119 W
Supply Voltage: 119 V
Current: 1.00 A

Beam Details

Distance	3 m	5 m	10 m	15 m	20 m
Beam Width	1.4 m	2.3 m	4.7 m	7 m	9.3 m

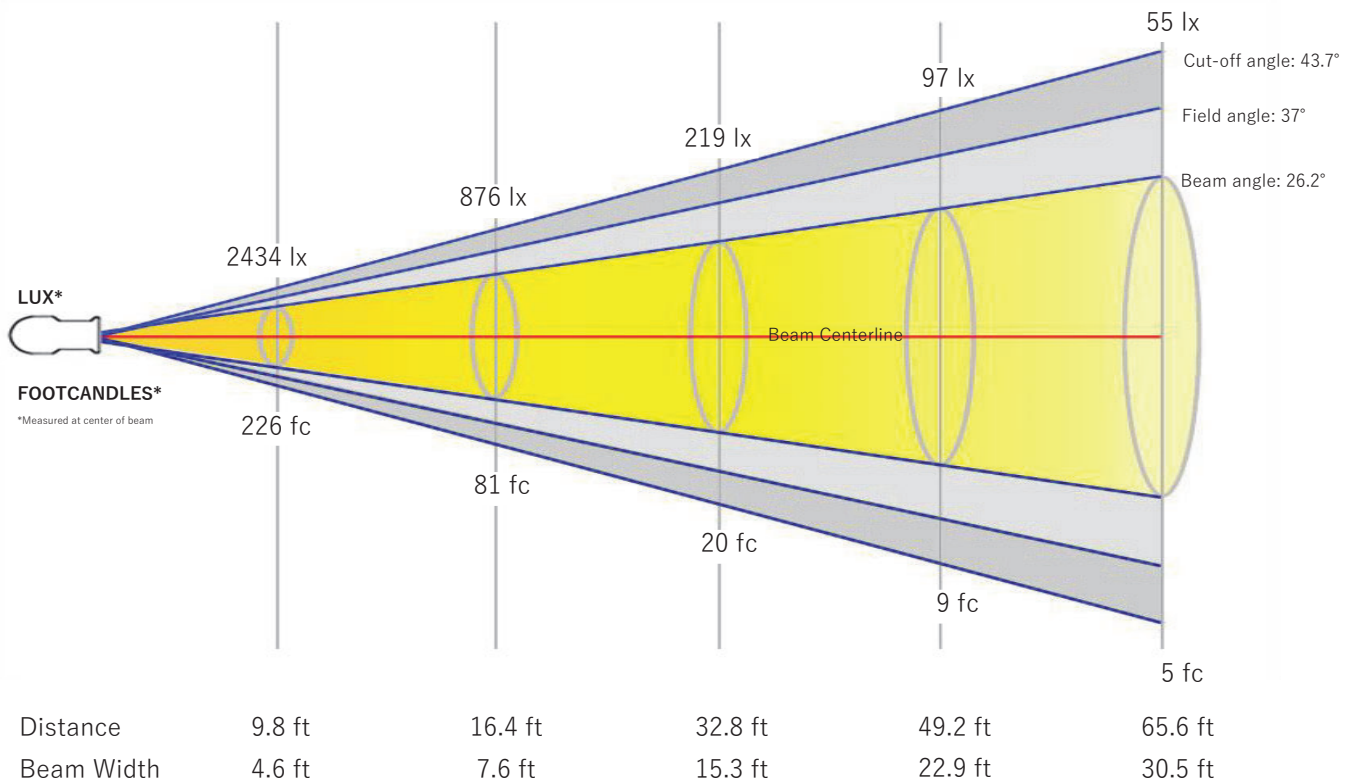

Beam Intensities from 1-20m

M	1	2	3	4	5	6	7	8	9	10	11	12	13	14	15	16	17	18	19	20
LX	21903	5476	2434	1369	876	608	447	342	270	219	181	152	130	112	97	86	76	68	61	55
FT	3.3	6.6	9.8	13.1	16.4	19.7	23	26.2	29.5	32.8	36.1	39.4	42.7	45.9	49.2	52.5	55.8	59.1	62.3	65.6
FC	2034.8	508.7	226.1	127.2	81.4	56.5	41.5	31.8	25.1	20.3	16.8	14.1	12	10.4	9	7.9	7	6.3	5.6	5.1

Angular Distribution

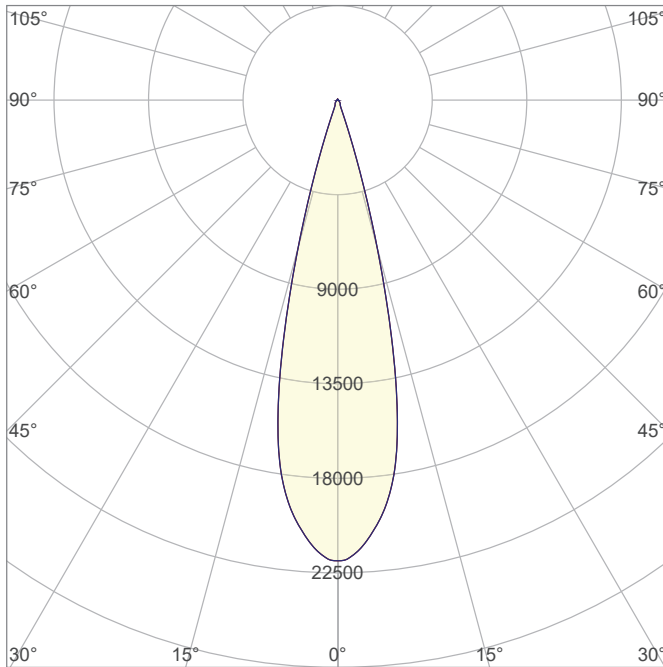

Beam Angle - 50%
26.2°
Field Angle - 10%
37°
Cutoff Angle - 2.5%
43.7°

ISO Diagrams

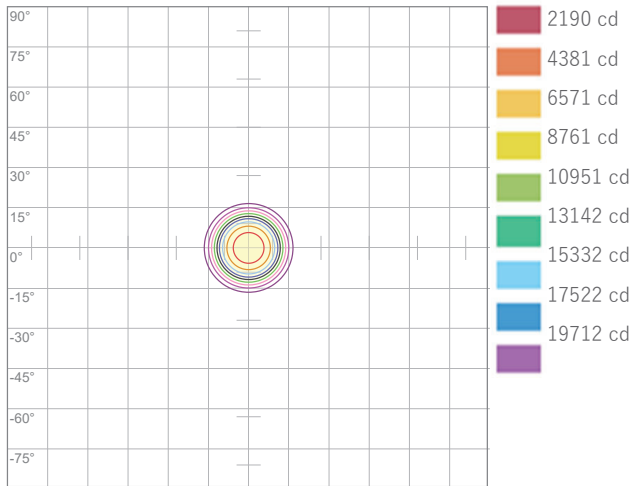

ISO Candela Diagram

Conditions:
Number of c-planes: 4
Candela at center: 21903 cd

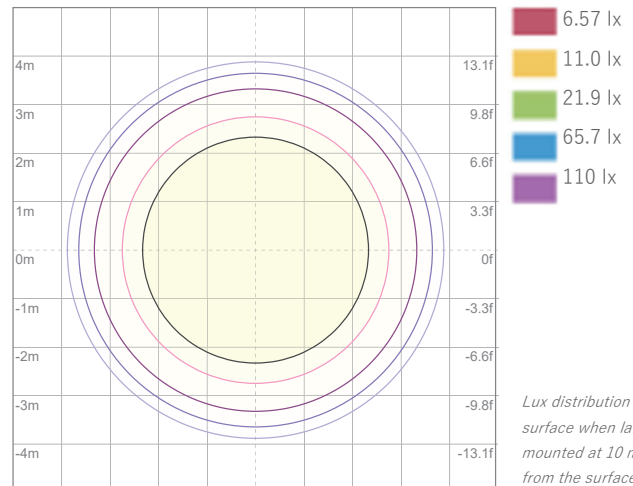

ISO LUX Diagram

Conditions:
Number of c-planes: 4
LUX at center: 219 lx

Lux distribution on a surface when lamp is mounted at 10 meters from the surface.

Linear Distribution

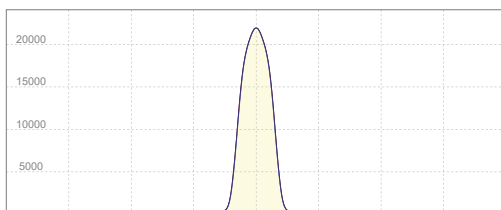

Peak Candela
21903 cd

Calculate Center Beam Intensities

$$\text{lux} = 21903 / \text{distance(m)}^2$$

$$\text{fc} = 21903 / \text{distance(ft)}^2$$

Key Measurements

Output

Total Lumen Output: 4338 lm

Peak Intensity: 21475 cd

Beam

Beam Angle (50%): 26.1°

Field Angle (10%): 36.9°

Cutoff Angle (2.5%): 43.8°

Color

Color Temperature: 6500 K

CRI: 89.7

TLCI: 91

TM30 R_F: 87.7

TM30 R_g: 106.2

Power Details

Efficacy: 29 Lumen/Watt

Power: 151.3 W

Supply Voltage: 119 V

Current: 1.27 A

Beam Details

Distance	3 m	5 m	10 m	15 m	20 m
Beam Width	1.4 m	2.3 m	4.6 m	7 m	9.3 m

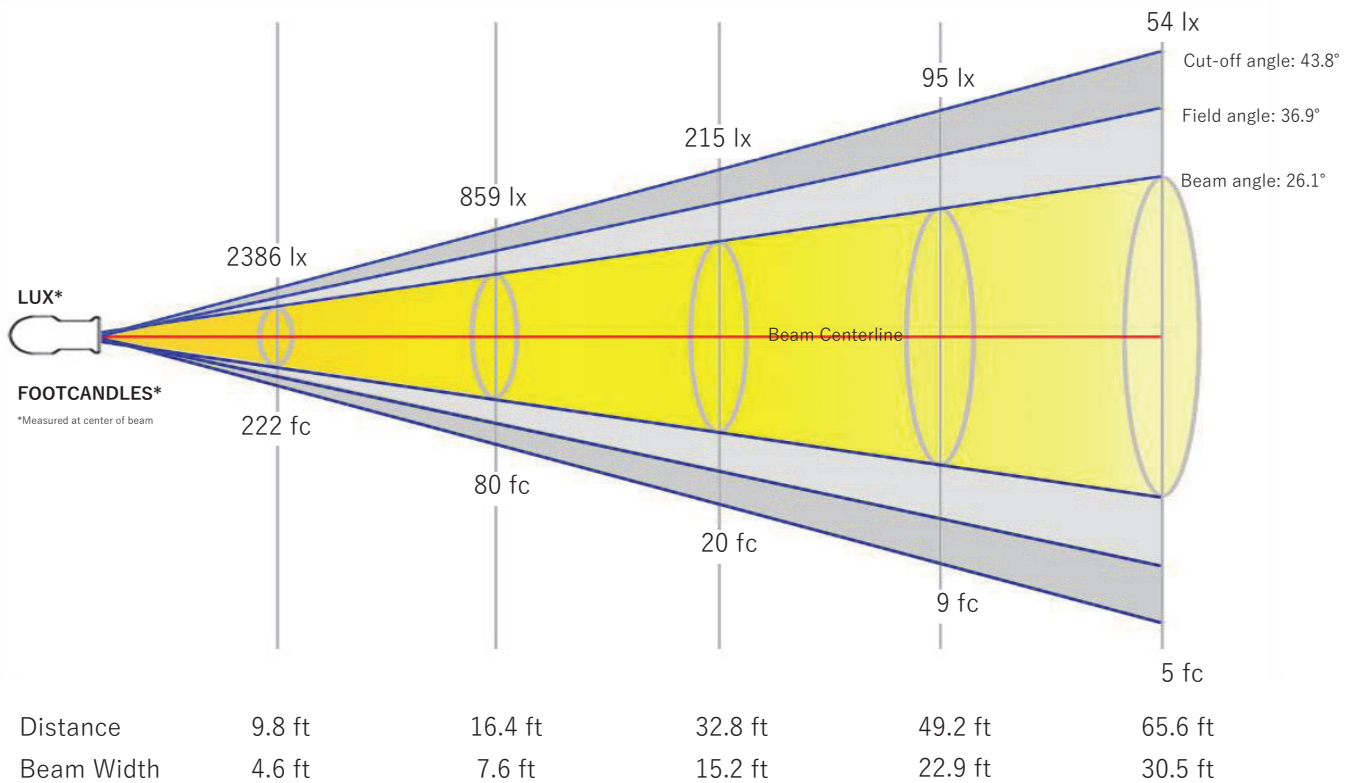

Beam Intensities from 1-20m

M	1	2	3	4	5	6	7	8	9	10	11	12	13	14	15	16	17	18	19	20
LX	21475	5369	2386	1342	859	597	438	336	265	215	177	149	127	110	95	84	74	66	59	54
FT	3.3	6.6	9.8	13.1	16.4	19.7	23	26.2	29.5	32.8	36.1	39.4	42.7	45.9	49.2	52.5	55.8	59.1	62.3	65.6
FC	1995.1	498.8	221.7	124.7	79.8	55.4	40.7	31.2	24.6	20	16.5	13.9	11.8	10.2	8.9	7.8	6.9	6.2	5.5	5

Angular Distribution

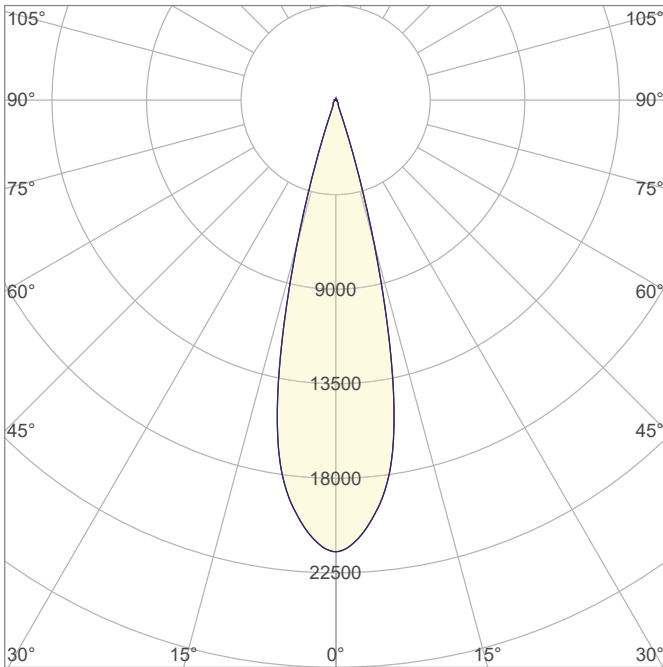

Beam Angle - 50%
26.1°
Field Angle - 10%
36.9°
Cutoff Angle - 2.5%
43.8°

ISO Diagrams

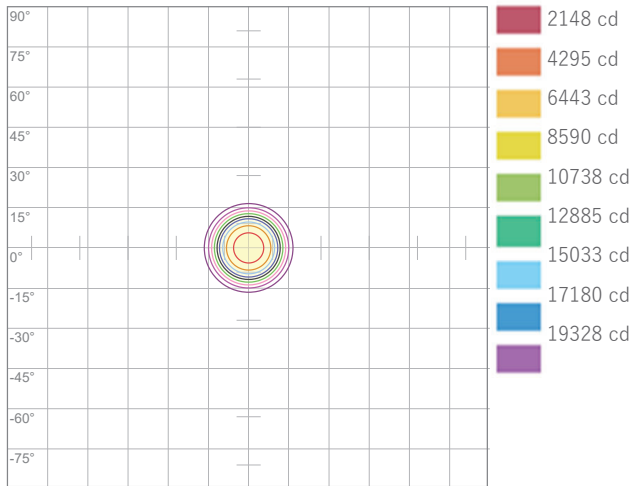

ISO Candela Diagram

Conditions:
Number of c-planes: 4
Candela at center: 21475 cd

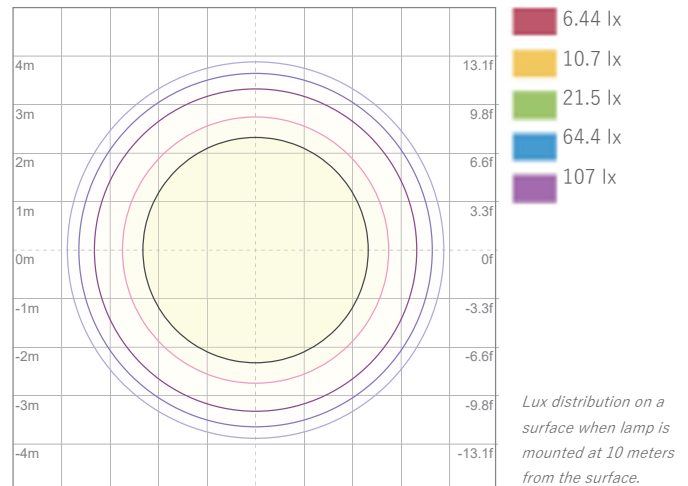

ISO LUX Diagram

Conditions:
Number of c-planes: 4
LUX at center: 215 lx

Lux distribution on a surface when lamp is mounted at 10 meters from the surface.

Linear Distribution

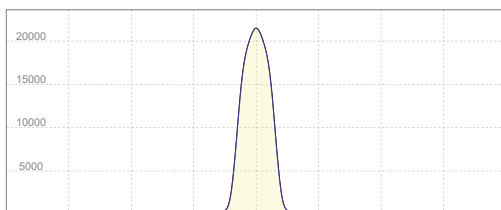

Peak Candela
21475 cd

Calculate Center Beam Intensities

$$\text{lux} = 21475 / \text{distance(m)}^2$$

$$\text{fc} = 21475 / \text{distance(ft)}^2$$

Key Measurements

Output

Total Lumen Output: 4245 lm
Peak Intensity: 21254 cd

Beam

Beam Angle (50%): 26.2°
Field Angle (10%): 37°
Cutoff Angle (2.5%): 43.8°

Color

Color Temperature: 7514 K
CRI: 90.2
TLCI: 91
TM30 R_F: 87.0
TM30 R_g: 104.3

Power Details

Efficacy: 28 Lumen/Watt
Power: 151.7 W
Supply Voltage: 119 V
Current: 1.27 A

Beam Details

Distance	3 m	5 m	10 m	15 m	20 m
Beam Width	1.4 m	2.3 m	4.7 m	7 m	9.3 m

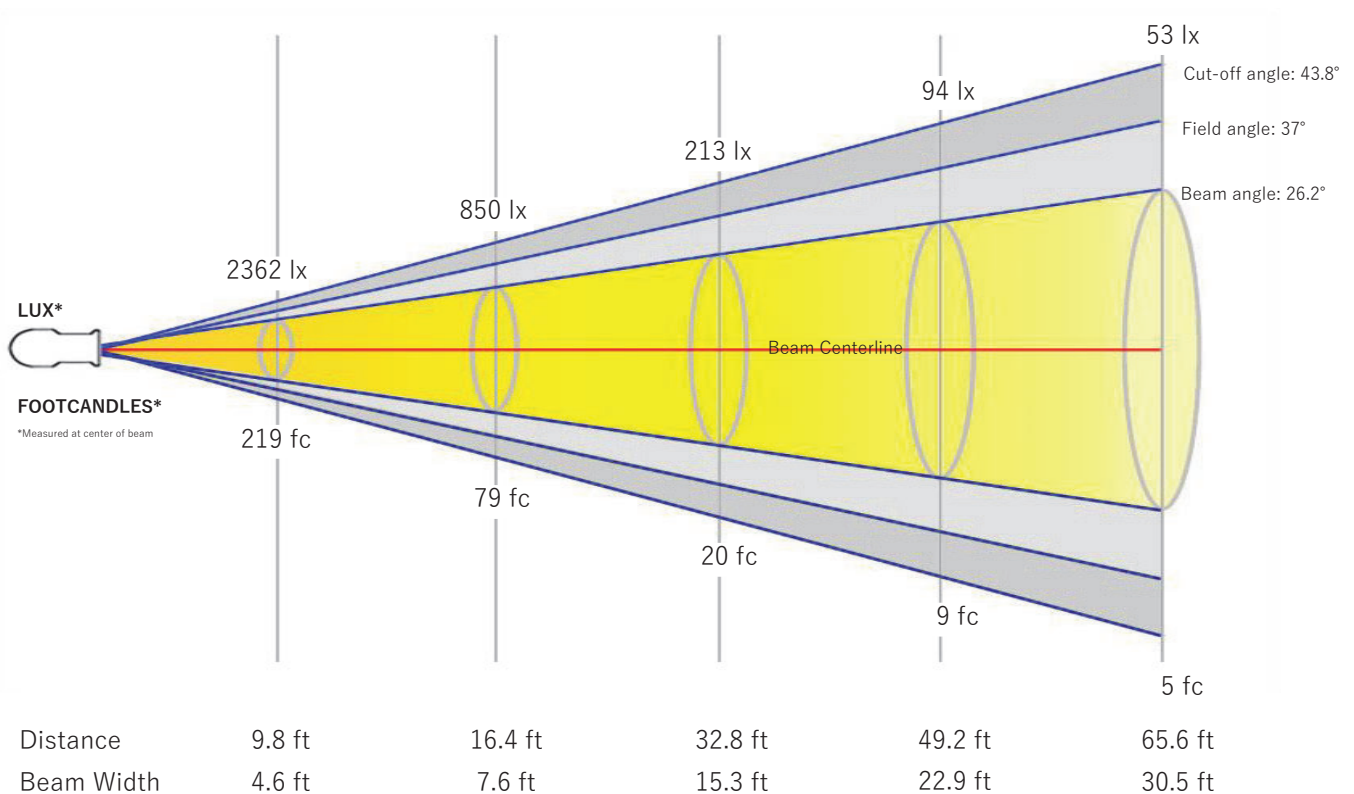

Beam Intensities from 1-20m

M	1	2	3	4	5	6	7	8	9	10	11	12	13	14	15	16	17	18	19	20
LX	21254	5314	2362	1328	850	590	434	332	262	213	176	148	126	108	94	83	74	66	59	53
FT	3.3	6.6	9.8	13.1	16.4	19.7	23	26.2	29.5	32.8	36.1	39.4	42.7	45.9	49.2	52.5	55.8	59.1	62.3	65.6
FC	1974.6	493.6	219.4	123.4	79	54.8	40.3	30.9	24.4	19.7	16.3	13.7	11.7	10.1	8.8	7.7	6.8	6.1	5.5	4.9

Angular Distribution

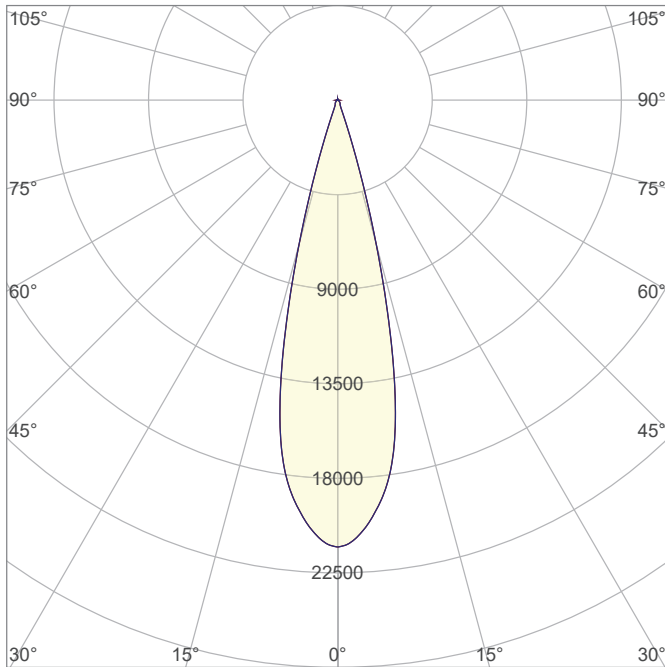

Beam Angle - 50%
26.2°
Field Angle - 10%
37°
Cutoff Angle - 2.5%
43.8°

ISO Diagrams

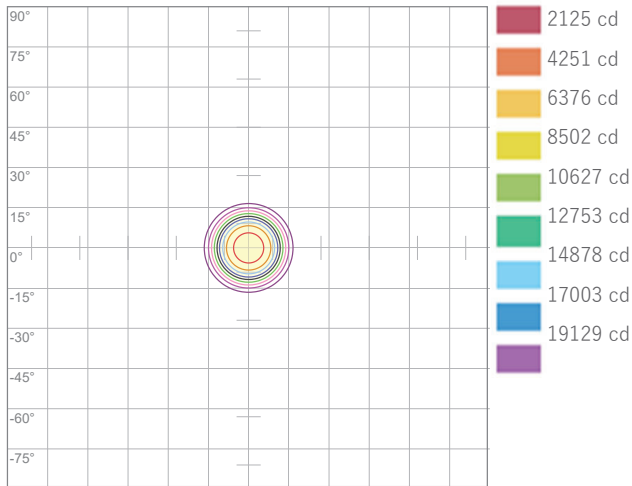

ISO Candela Diagram

Conditions:
Number of c-planes: 4
Candela at center: 21254 cd

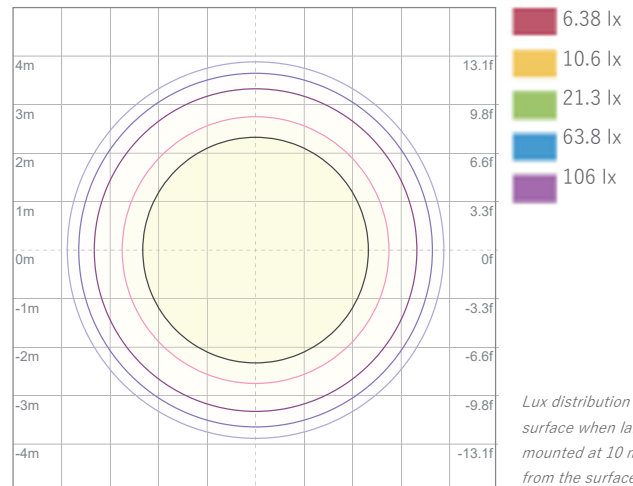

ISO LUX Diagram

Conditions:
Number of c-planes: 4
LUX at center: 213 lx

Lux distribution on a surface when lamp is mounted at 10 meters from the surface.

Linear Distribution

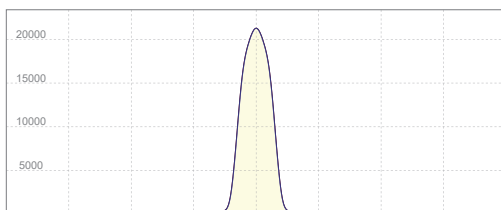

Peak Candela
21254 cd

Calculate Center Beam Intensities

$$\text{lux} = 21254 / \text{distance(m)}^2$$

$$\text{fc} = 21254 / \text{distance(ft)}^2$$

Key Measurements

Output

Total Lumen Output: 4225 lm

Peak Intensity: 21125 cd

Beam

Beam Angle (50%): 26.2°

Field Angle (10%): 37°

Cutoff Angle (2.5%): 43.8°

Color

Color Temperature: 8491 K

CRI: 89.9

TLCI: 90

TM30 R_F: 86.1

TM30 R_g: 102.5

Power Details

Efficacy: 28 Lumen/Watt

Power: 152.1 W

Supply Voltage: 119 V

Current: 1.28 A

Beam Details

Distance	3 m	5 m	10 m	15 m	20 m
Beam Width	1.4 m	2.3 m	4.7 m	7 m	9.3 m

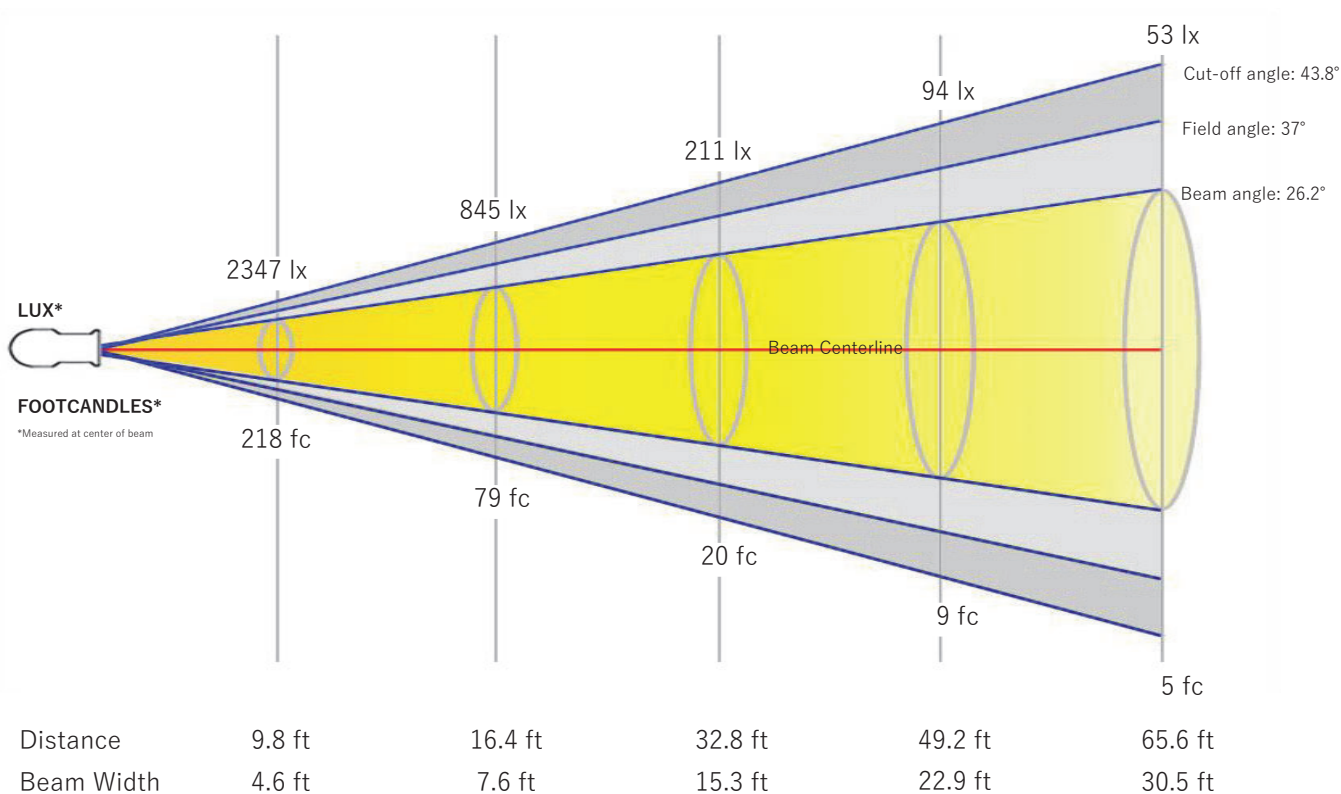

Beam Intensities from 1-20m

M	1	2	3	4	5	6	7	8	9	10	11	12	13	14	15	16	17	18	19	20
LX	21125	5281	2347	1320	845	587	431	330	261	211	175	147	125	108	94	83	73	65	59	53
FT	3.3	6.6	9.8	13.1	16.4	19.7	23	26.2	29.5	32.8	36.1	39.4	42.7	45.9	49.2	52.5	55.8	59.1	62.3	65.6
FC	1962.6	490.6	218.1	122.7	78.5	54.5	40.1	30.7	24.2	19.6	16.2	13.6	11.6	10	8.7	7.7	6.8	6.1	5.4	4.9

Angular Distribution

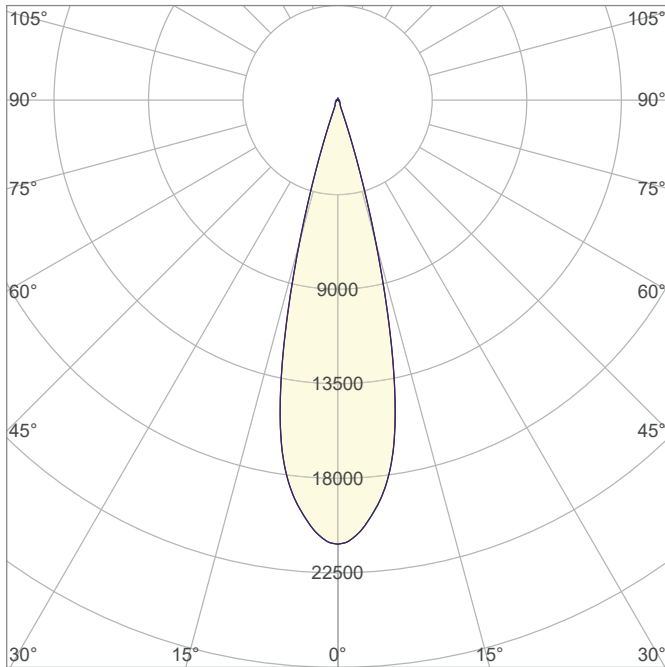

Beam Angle - 50%
26.2°
Field Angle - 10%
37°
Cutoff Angle - 2.5%
43.8°

ISO Diagrams

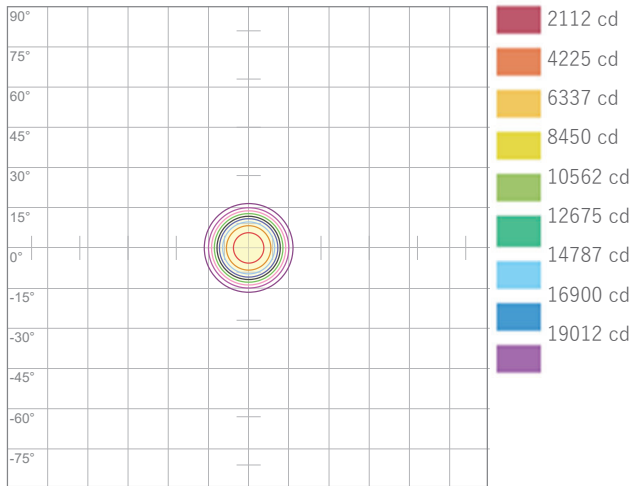

ISO Candela Diagram

Conditions:
Number of c-planes: 4
Candela at center: 21125 cd

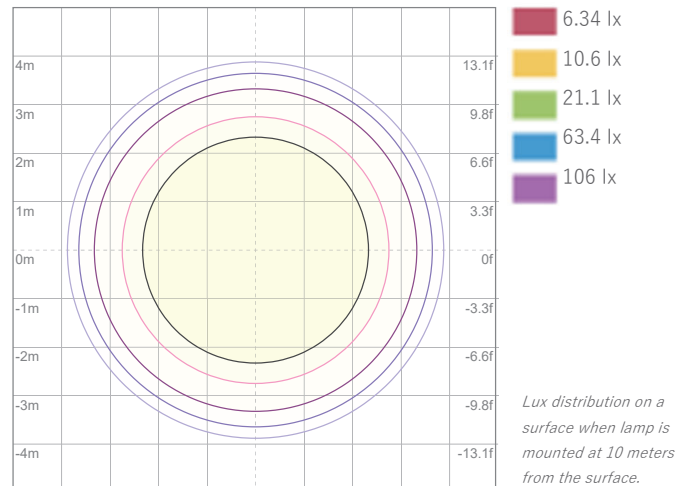

ISO LUX Diagram

Conditions:
Number of c-planes: 4
LUX at center: 211 lx

Linear Distribution

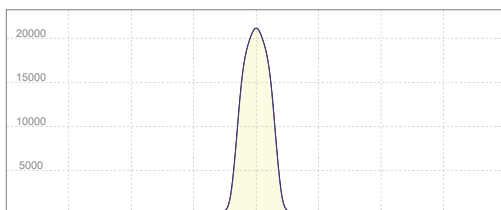

Peak Candela
21125 cd

Calculate Center Beam Intensities

$$\text{lux} = 21125 / \text{distance(m)}^2$$

$$\text{fc} = 21125 / \text{distance(ft)}^2$$

Key Measurements

Output

Total Lumen Output: 4188 lm
Peak Intensity: 5729 cd

Beam

Beam Angle (50%): 55.3°
Field Angle (10%): 67.3°
Cutoff Angle (2.5%): 85.2°

Color

Color Temperature: 6049 K
CRI: 88.5
TLCI: 90
TM30 R_F: 87.8
TM30 R_g: 107.6

Power Details

Efficacy: 28 Lumen/Watt
Power: 152 W
Supply Voltage: 119 V
Current: 1.28 A

Beam Details

Distance	3 m	5 m	10 m	15 m	20 m
Beam Width	3.1 m	5.2 m	10.5 m	15.7 m	21 m

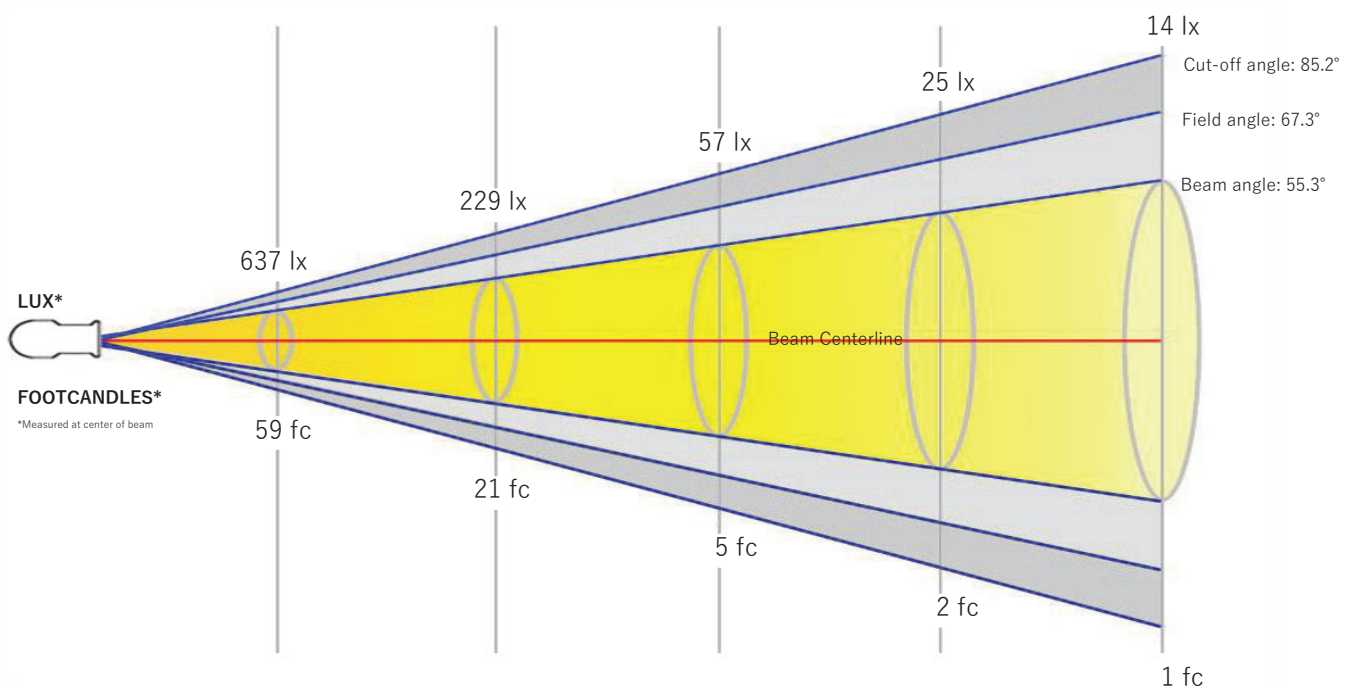

Distance	9.8 ft	16.4 ft	32.8 ft	49.2 ft	65.6 ft
Beam Width	10.3 ft	17.2 ft	34.4 ft	51.6 ft	68.8 ft

Beam Intensities from 1-20m

M	1	2	3	4	5	6	7	8	9	10	11	12	13	14	15	16	17	18	19	20
LX	5729	1432	637	358	229	159	117	90	71	57	47	40	34	29	25	22	20	18	16	14
FT	3.3	6.6	9.8	13.1	16.4	19.7	23	26.2	29.5	32.8	36.1	39.4	42.7	45.9	49.2	52.5	55.8	59.1	62.3	65.6
FC	532.2	133.1	59.1	33.3	21.3	14.8	10.9	8.3	6.6	5.3	4.4	3.7	3.1	2.7	2.4	2.1	1.8	1.6	1.5	1.3

Angular Distribution

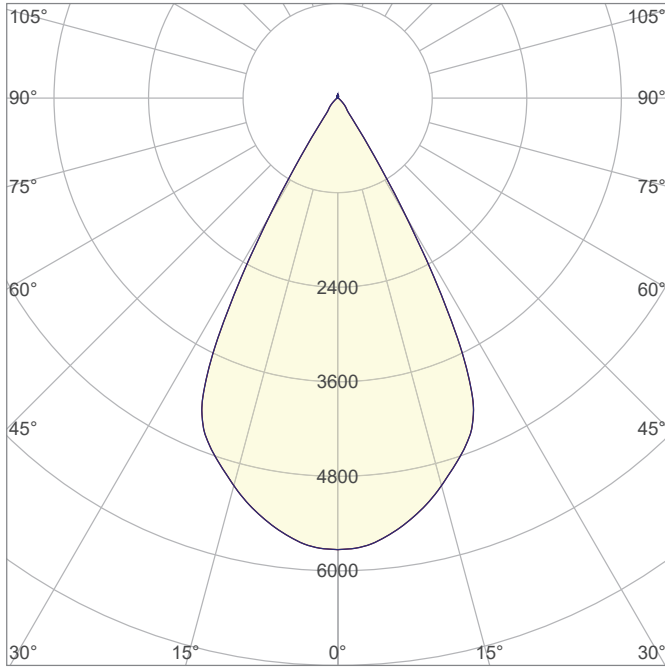

Beam Angle - 50%
55.3°
Field Angle - 10%
67.3°
Cutoff Angle - 2.5%
85.2°

ISO Diagrams

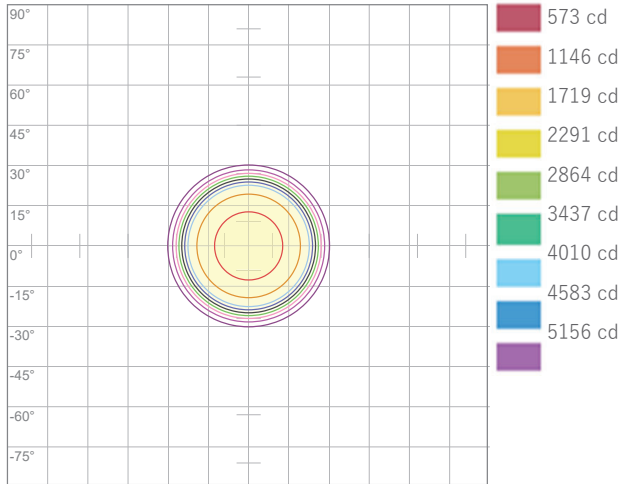

ISO Candela Diagram

Conditions:
Number of c-planes: 4
Candela at center: 5729 cd

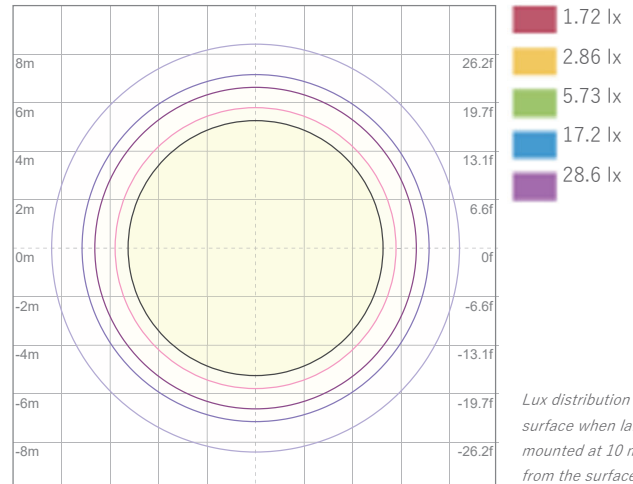

ISO LUX Diagram

Conditions:
Number of c-planes: 4
LUX at center: 57.3 lx

Lux distribution on a surface when lamp is mounted at 10 meters from the surface.

Linear Distribution

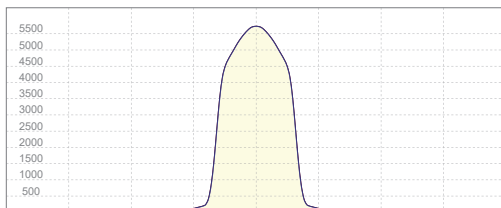

Peak Candela
5729 cd

Calculate Center Beam Intensities

$$\text{lux} = 5729 / \text{distance(m)}^2$$

$$\text{fc} = 5729 / \text{distance(ft)}^2$$

Key Measurements

Output

Total Lumen Output: 4444 lm

Peak Intensity: 6157 cd

Beam

Beam Angle (50%): 55.2°

Field Angle (10%): 67°

Cutoff Angle (2.5%): 84.8°

Color

Color Temperature: 3240 K

CRI: 90.3

TLCI: 92

TM30 R_F: 91.5

TM30 R_g: 106.8

Power Details

Efficacy: 29 Lumen/Watt

Power: 154.8 W

Supply Voltage: 119 V

Current: 1.30 A

Beam Details

Distance	3 m	5 m	10 m	15 m	20 m
Beam Width	3.1 m	5.2 m	10.5 m	15.7 m	20.9 m

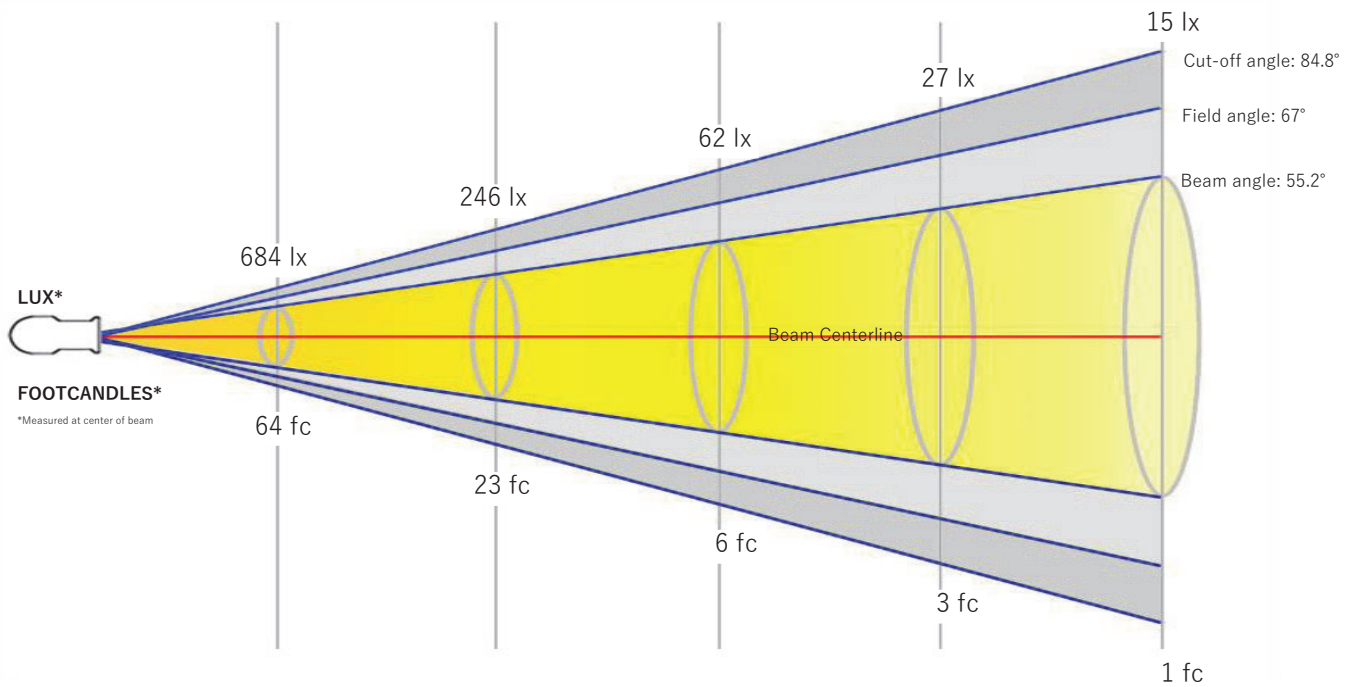

Distance	9.8 ft	16.4 ft	32.8 ft	49.2 ft	65.6 ft
Beam Width	10.2 ft	17.1 ft	34.3 ft	51.4 ft	68.6 ft

Beam Intensities from 1-20m

M	1	2	3	4	5	6	7	8	9	10	11	12	13	14	15	16	17	18	19	20
LX	6157	1539	684	385	246	171	126	96	76	62	51	43	36	31	27	24	21	19	17	15
FT	3.3	6.6	9.8	13.1	16.4	19.7	23	26.2	29.5	32.8	36.1	39.4	42.7	45.9	49.2	52.5	55.8	59.1	62.3	65.6
FC	572	143	63.6	35.8	22.9	15.9	11.7	8.9	7.1	5.7	4.7	4	3.4	2.9	2.5	2.2	2	1.8	1.6	1.4

Angular Distribution

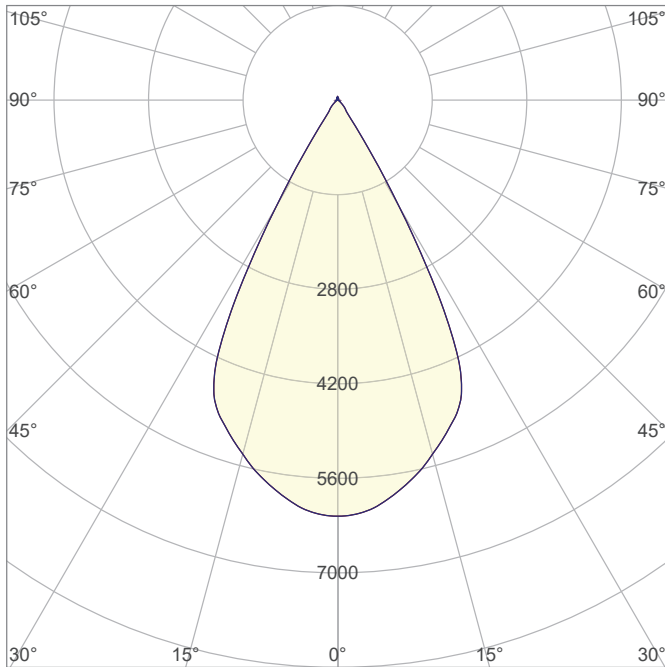

Beam Angle - 50%
55.2°
Field Angle - 10%
67°
Cutoff Angle - 2.5%
84.8°

ISO Diagrams

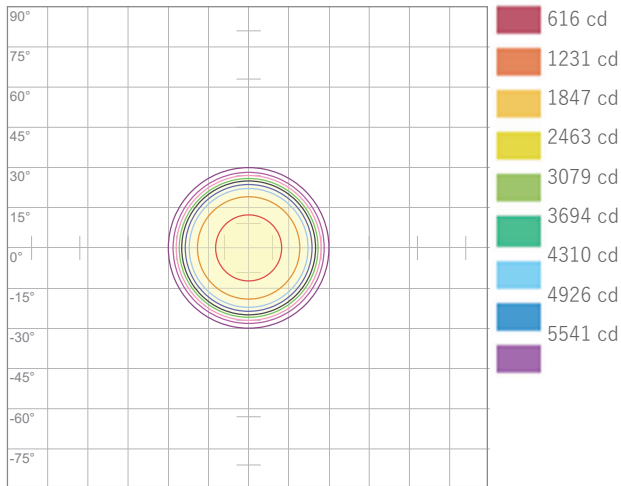

ISO Candela Diagram

Conditions:
Number of c-planes: 4
Candela at center: 6157 cd

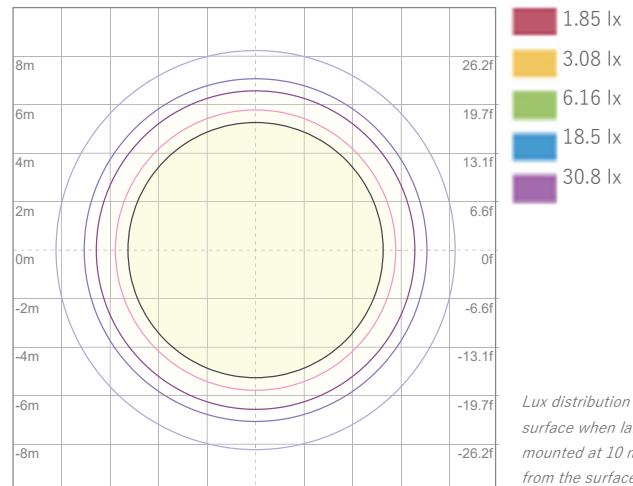

ISO LUX Diagram

Conditions:
Number of c-planes: 4
LUX at center: 61.6 lx

Lux distribution on a surface when lamp is mounted at 10 meters from the surface.

Linear Distribution

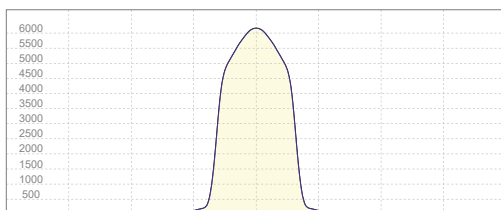

Peak Candela
6157 cd

Calculate Center Beam Intensities

$$\text{lux} = 6157 / \text{distance(m)}^2$$

$$\text{fc} = 6157 / \text{distance(ft)}^2$$

Key Measurements

Output

Total Lumen Output: 4307 lm

Peak Intensity: 5890 cd

Beam

Beam Angle (50%): 55.4°

Field Angle (10%): 67°

Cutoff Angle (2.5%): 85.2°

Color

Color Temperature: 4548 K

CRI: 86.1

TLCI: 87

TM30 R_F: 88.5

TM30 R_g: 109.6

Power Details

Efficacy: 28 Lumen/Watt

Power: 153 W

Supply Voltage: 119 V

Current: 1.29 A

Beam Details

Distance	3 m	5 m	10 m	15 m	20 m
Beam Width	3.1 m	5.2 m	10.5 m	15.7 m	21 m

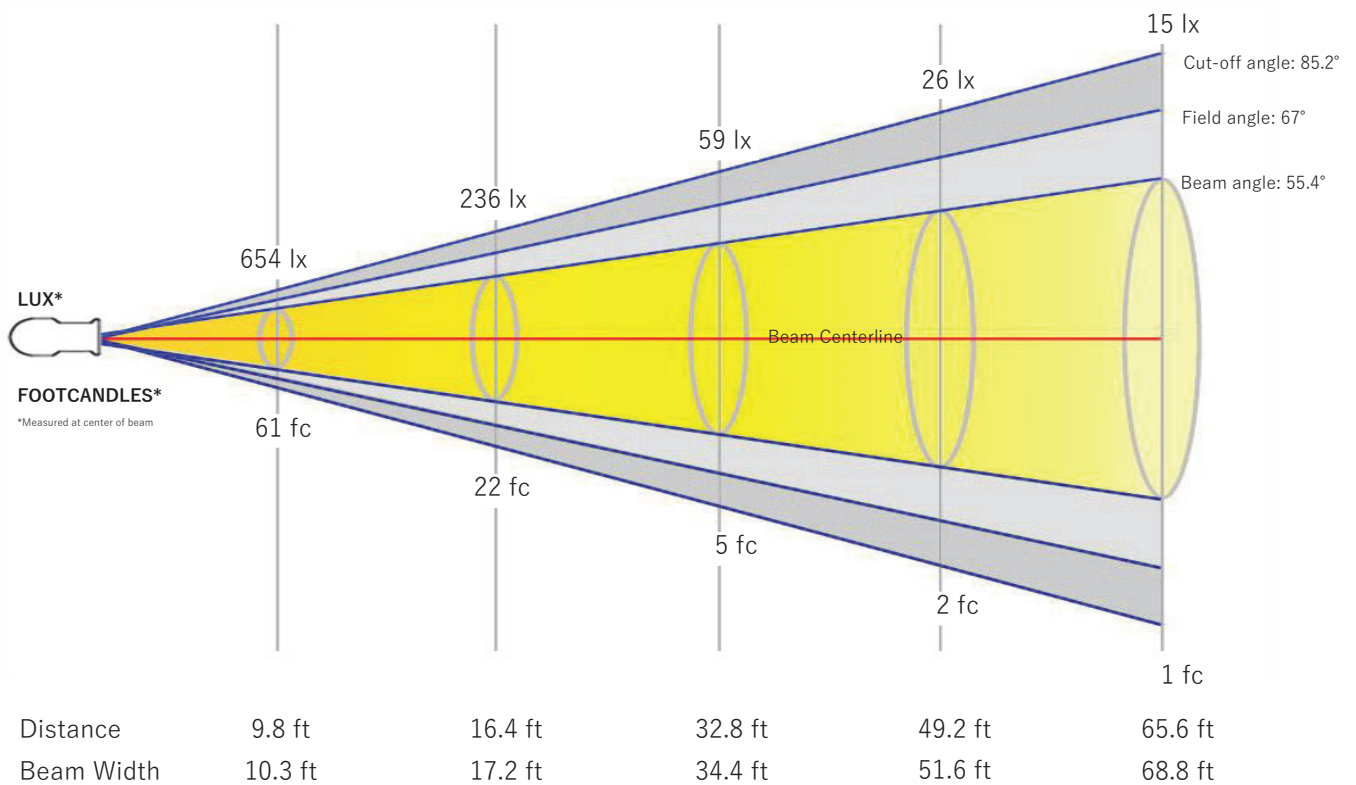

Beam Intensities from 1-20m

M	1	2	3	4	5	6	7	8	9	10	11	12	13	14	15	16	17	18	19	20
LX	5890	1473	654	368	236	164	120	92	73	59	49	41	35	30	26	23	20	18	16	15
FT	3.3	6.6	9.8	13.1	16.4	19.7	23	26.2	29.5	32.8	36.1	39.4	42.7	45.9	49.2	52.5	55.8	59.1	62.3	65.6
FC	547.2	136.8	60.8	34.2	21.9	15.2	11.2	8.6	6.8	5.5	4.5	3.8	3.2	2.8	2.4	2.1	1.9	1.7	1.5	1.4

Angular Distribution

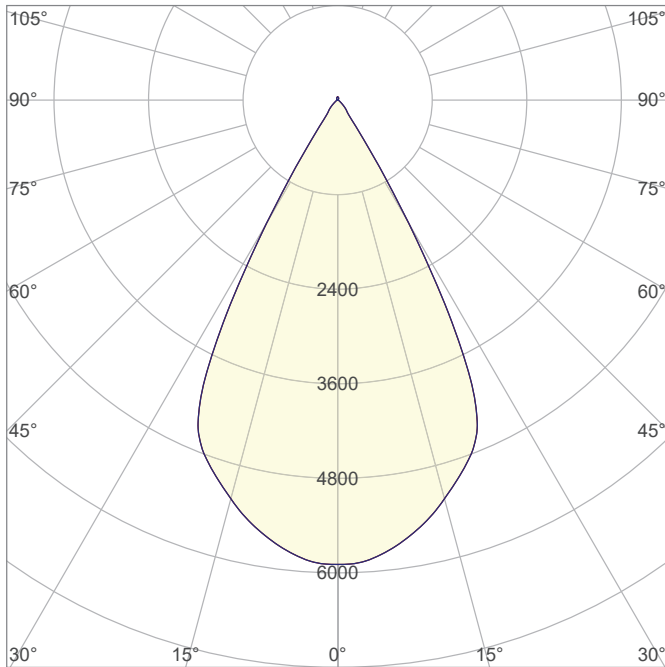

Beam Angle - 50%
55.4°
Field Angle - 10%
67°
Cutoff Angle - 2.5%
85.2°

ISO Diagrams

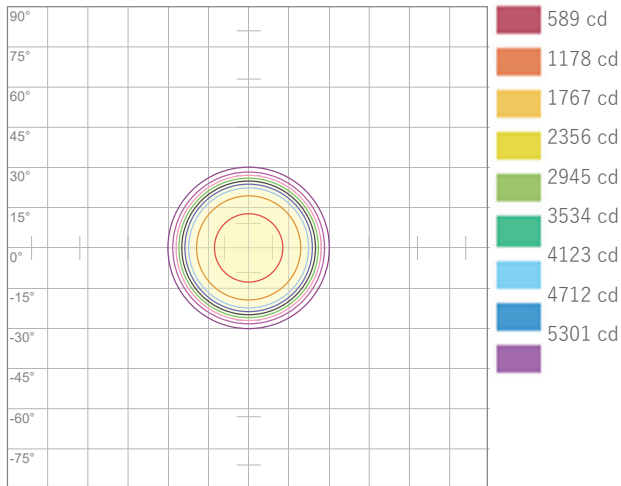

ISO Candela Diagram

Conditions:
Number of c-planes: 4
Candela at center: 5890 cd

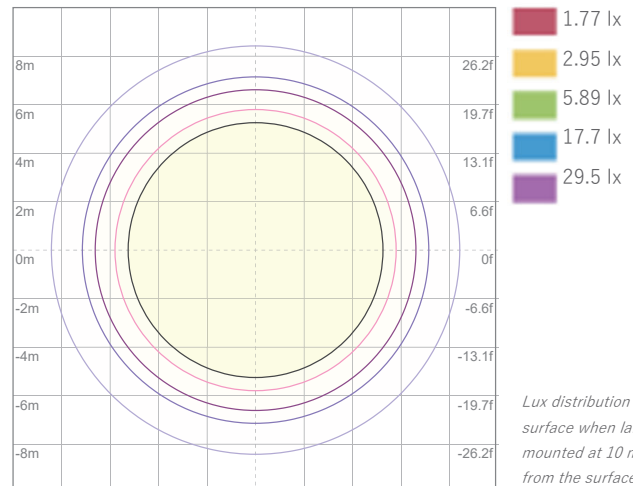

ISO LUX Diagram

Conditions:
Number of c-planes: 4
LUX at center: 58.9 lx

Lux distribution on a surface when lamp is mounted at 10 meters from the surface.

Linear Distribution

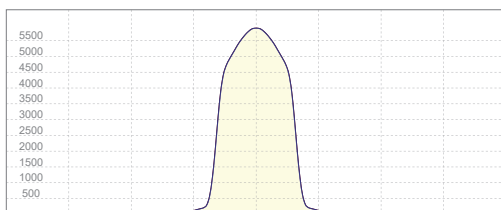

Peak Candela
5890 cd

Calculate Center Beam Intensities

$$\text{lux} = 5890 / \text{distance(m)}^2$$

$$\text{fc} = 5890 / \text{distance(ft)}^2$$

Key Measurements

Output

Total Lumen Output: 4228 lm
Peak Intensity: 5785 cd

Beam

Beam Angle (50%): 55.4°
Field Angle (10%): 67.1°
Cutoff Angle (2.5%): 85.1°

Color

Color Temperature: 6542 K
CRI: 89.5
TLCI: 91
TM30 R_F: 87.6
TM30 R_g: 106.0

Power Details

Efficacy: 28 Lumen/Watt
Power: 153.6 W
Supply Voltage: 118 V
Current: 1.30 A

Beam Details

Distance	3 m	5 m	10 m	15 m	20 m
Beam Width	3.1 m	5.2 m	10.5 m	15.7 m	21 m

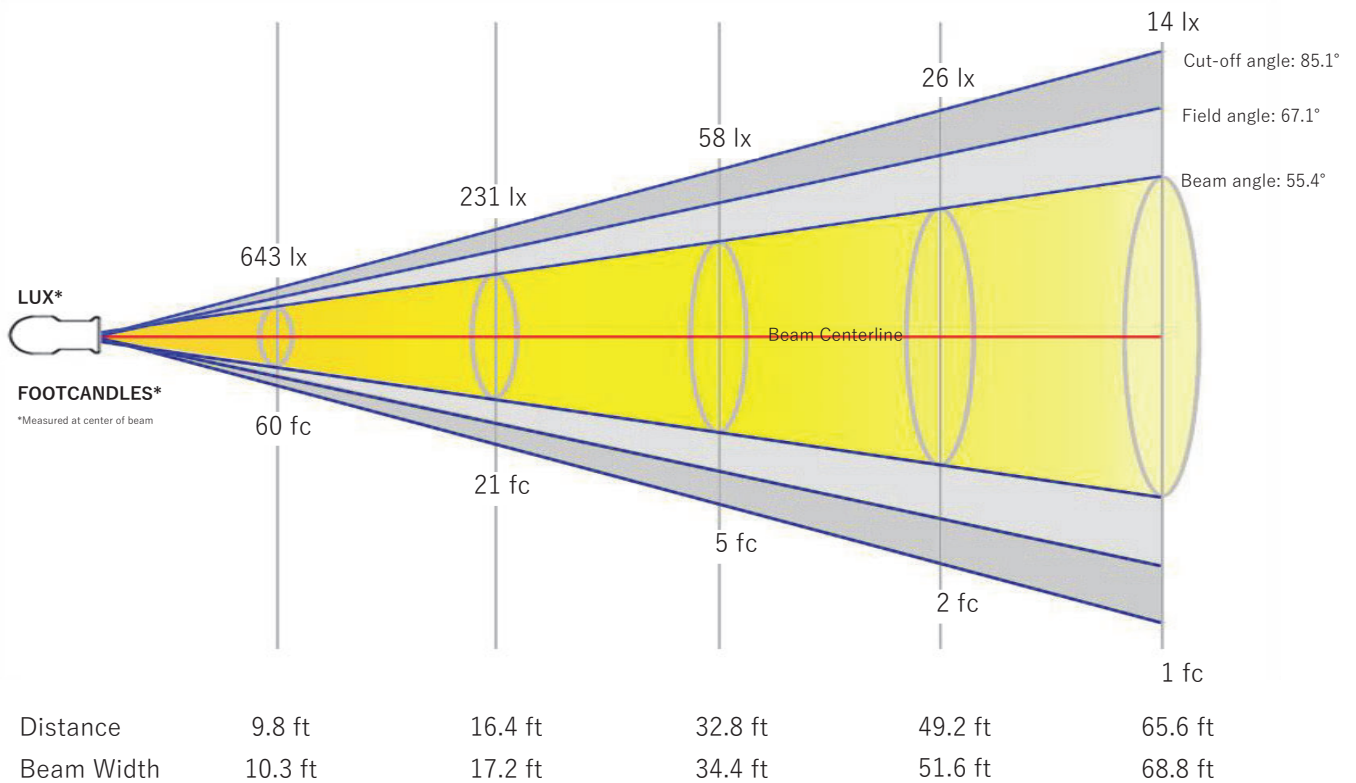

Beam Intensities from 1-20m

M	1	2	3	4	5	6	7	8	9	10	11	12	13	14	15	16	17	18	19	20
LX	5785	1446	643	362	231	161	118	90	71	58	48	40	34	30	26	23	20	18	16	14
FT	3.3	6.6	9.8	13.1	16.4	19.7	23	26.2	29.5	32.8	36.1	39.4	42.7	45.9	49.2	52.5	55.8	59.1	62.3	65.6
FC	537.5	134.4	59.7	33.6	21.5	14.9	11	8.4	6.6	5.4	4.4	3.7	3.2	2.7	2.4	2.1	1.9	1.7	1.5	1.3

Angular Distribution

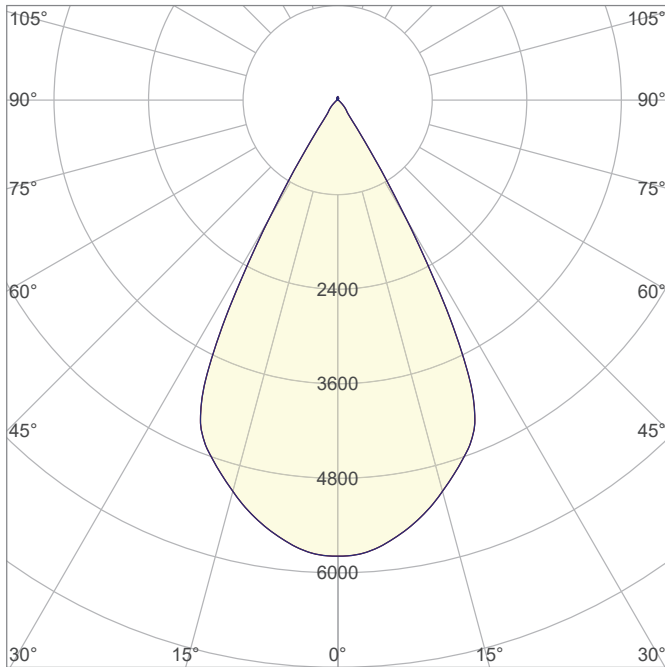

Beam Angle - 50%
55.4°
Field Angle - 10%
67.1°
Cutoff Angle - 2.5%
85.1°

ISO Diagrams

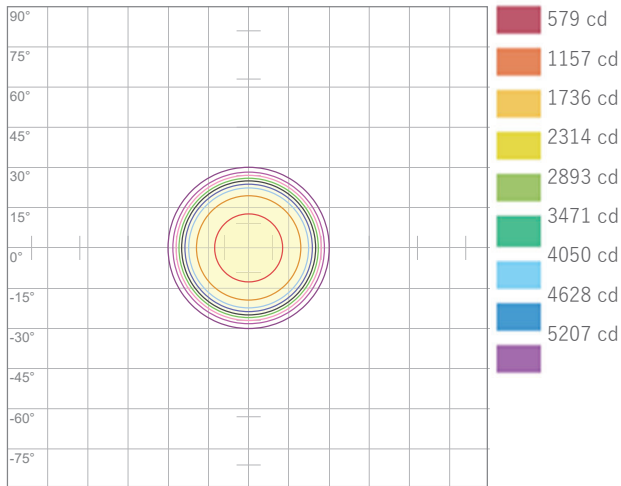

ISO Candela Diagram

Conditions:
Number of c-planes: 4
Candela at center: 5785 cd

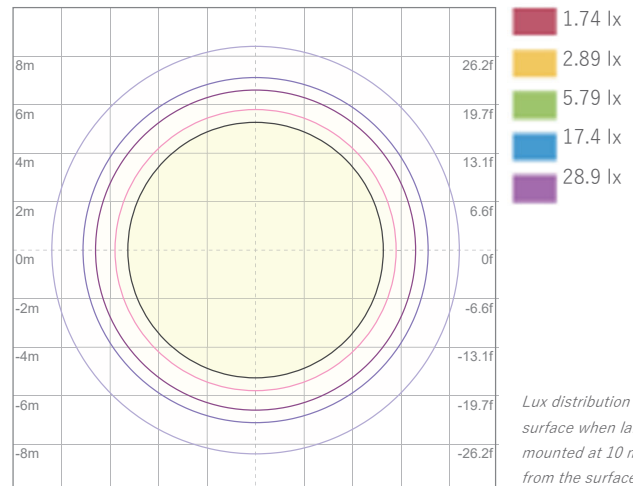

ISO LUX Diagram

Conditions:
Number of c-planes: 4
LUX at center: 57.9 lx

Lux distribution on a surface when lamp is mounted at 10 meters from the surface.

Linear Distribution

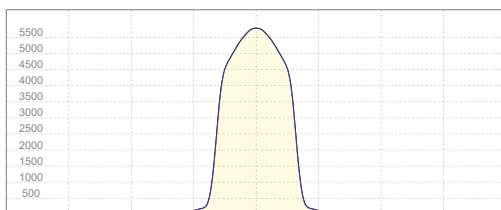

Peak Candela
5785 cd

Calculate Center Beam Intensities

$$\text{lux} = 5785 / \text{distance(m)}^2$$

$$\text{fc} = 5785 / \text{distance(ft)}^2$$

Key Measurements

Output

Total Lumen Output: 4103 lm

Peak Intensity: 5626 cd

Beam

Beam Angle (50%): 55.3°

Field Angle (10%): 67.2°

Cutoff Angle (2.5%): 85.4°

Color

Color Temperature: 8469 K

CRI: 89.8

TLCI: 90

TM30 R_F: 86.0

TM30 R_g: 102.3

Power Details

Efficacy: 27 Lumen/Watt

Power: 152.5 W

Supply Voltage: 119 V

Current: 1.28 A

Beam Details

Distance	3 m	5 m	10 m	15 m	20 m
Beam Width	3.1 m	5.2 m	10.5 m	15.7 m	21 m

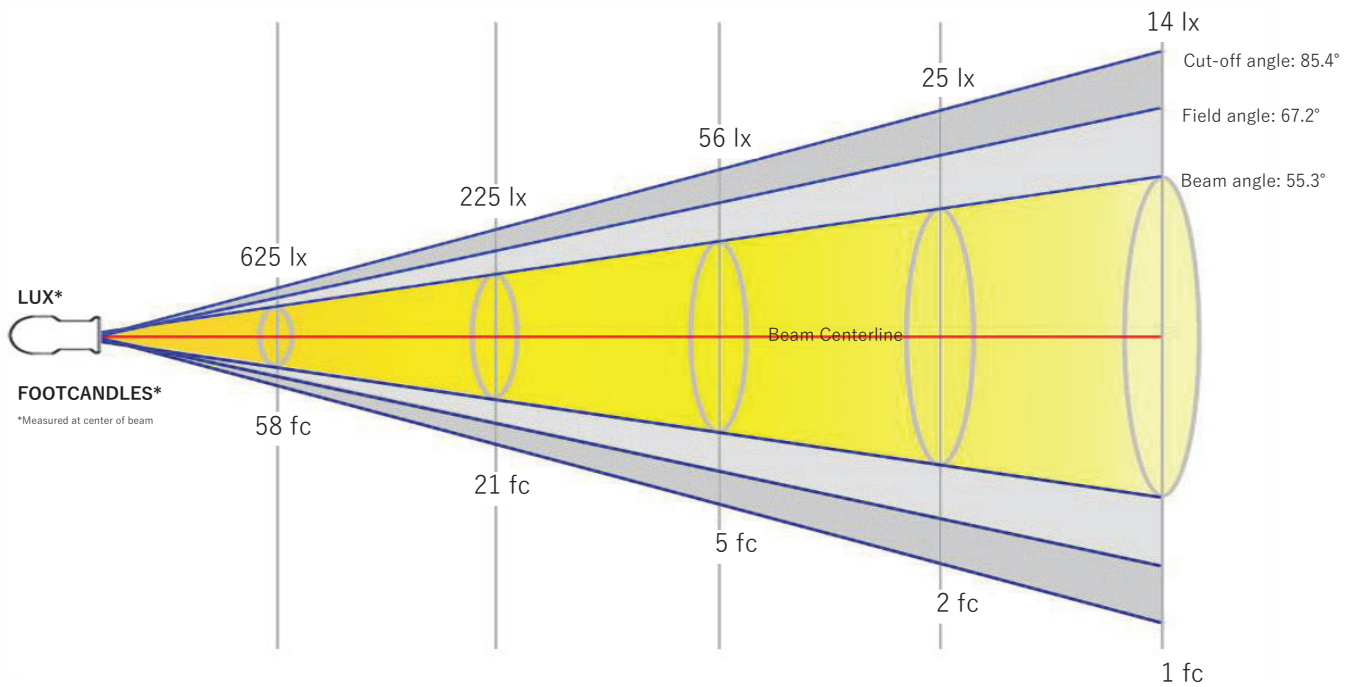

Distance	9.8 ft	16.4 ft	32.8 ft	49.2 ft	65.6 ft
Beam Width	10.3 ft	17.2 ft	34.4 ft	51.5 ft	68.7 ft

Beam Intensities from 1-20m

M	1	2	3	4	5	6	7	8	9	10	11	12	13	14	15	16	17	18	19	20
LX	5626	1407	625	352	225	156	115	88	69	56	46	39	33	29	25	22	19	17	16	14
FT	3.3	6.6	9.8	13.1	16.4	19.7	23	26.2	29.5	32.8	36.1	39.4	42.7	45.9	49.2	52.5	55.8	59.1	62.3	65.6
FC	522.7	130.7	58.1	32.7	20.9	14.5	10.7	8.2	6.5	5.2	4.3	3.6	3.1	2.7	2.3	2	1.8	1.6	1.4	1.3

Angular Distribution

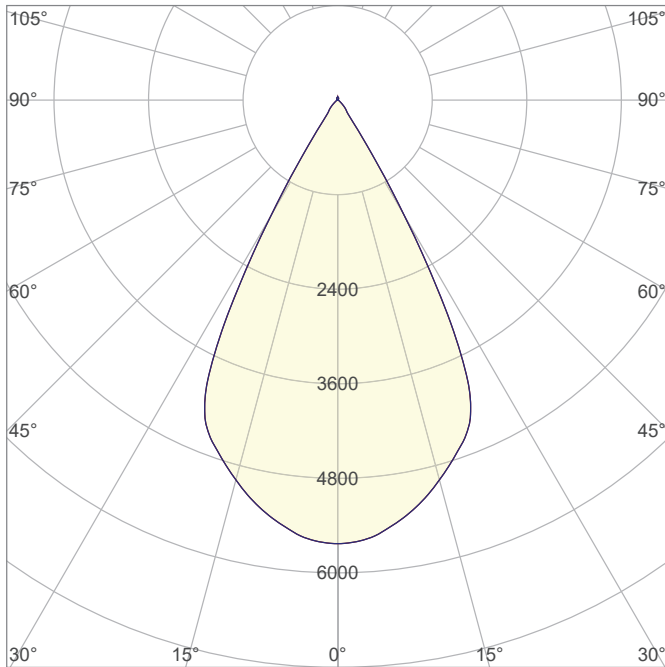

Beam Angle - 50%
55.3°
Field Angle - 10%
67.2°
Cutoff Angle - 2.5%
85.4°

ISO Diagrams

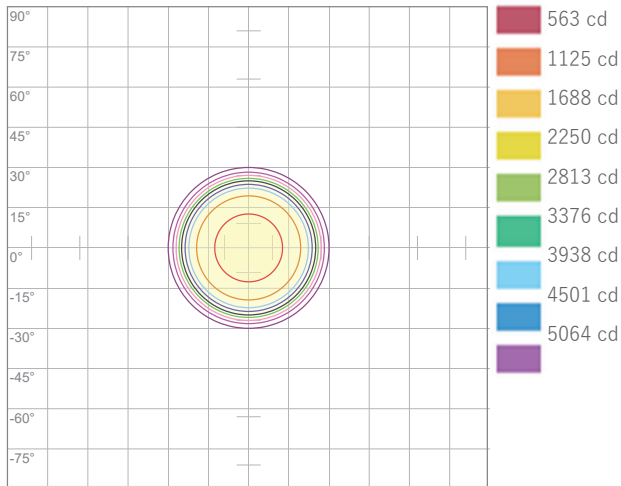

ISO Candela Diagram

Conditions:
Number of c-planes: 4
Candela at center: 5626 cd

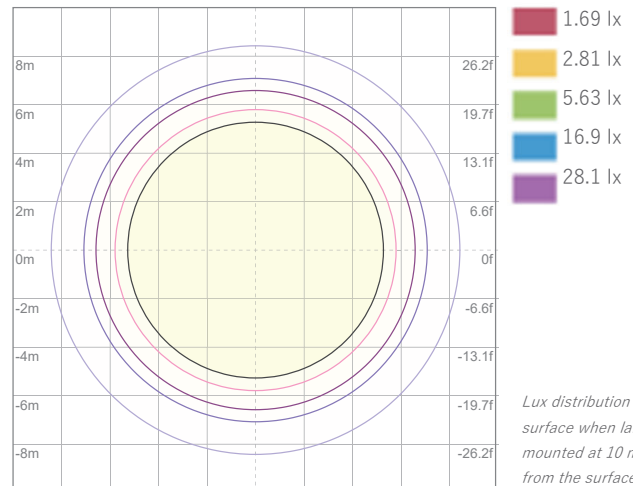

ISO LUX Diagram

Conditions:
Number of c-planes: 4
LUX at center: 56.3 lx

Lux distribution on a surface when lamp is mounted at 10 meters from the surface.

Linear Distribution

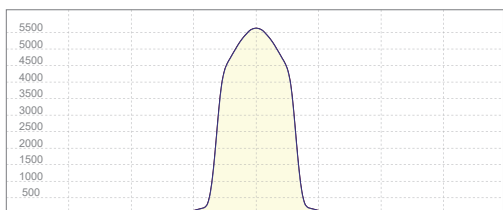

Peak Candela
5626 cd

Calculate Center Beam Intensities

$$\text{lux} = 5626 / \text{distance(m)}^2$$

$$\text{fc} = 5626 / \text{distance(ft)}^2$$

Color Temperature: 6017K

Accuracy Metric Overview

Color Rendering Index	Color Rendering Index, R9 (Red Component)	TM-30 Color Fidelity	TM-30 Color Gamut	Television Lighting Consistency Index	Color Quality Scale	Color Coordinate- CIE 1931	Color Coordinate- CIE 1931	Deviation from Black Body	SSI [CIE A] Tungsten	SSI [CIE D65] Daylight
CRI	CRI R9	TM30 R _f	TM30 R _g	TLCI	CQS	x	Y	Δuv	SSIt	SSId
88.8	62.5	87.9	107.3	90	90.7	0.322	0.331	-0.0003	30	54

CIE 1931

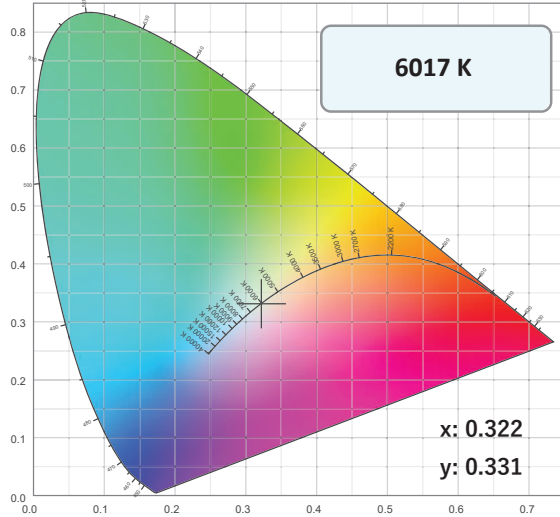

CIE 1931 ZOOMED

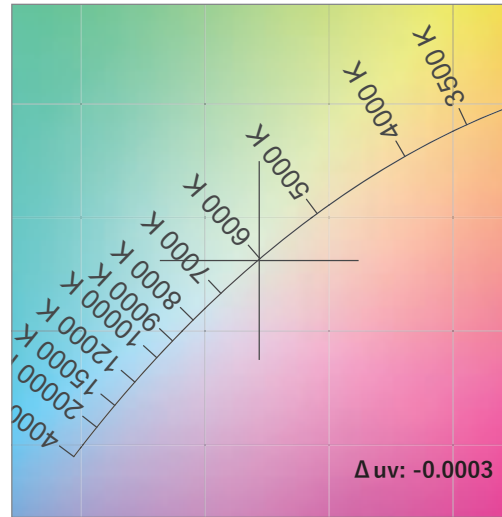

CRI: 88.8 (R1-R8)

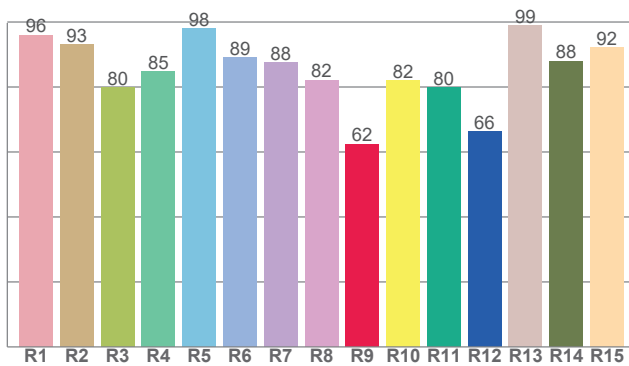

Spectral Power Distribution (SPD)

Dominant Wavelength 596 nm

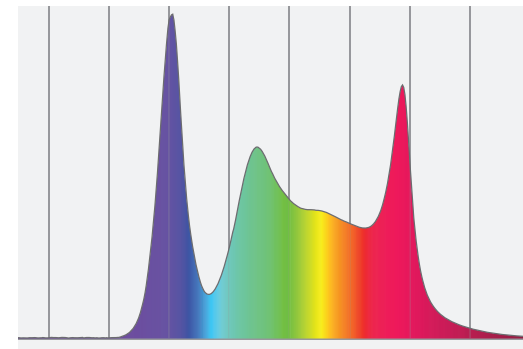

SSI Spectral Variance Graph- Tungsten

SSI [CIE A] 30

Spectral variance

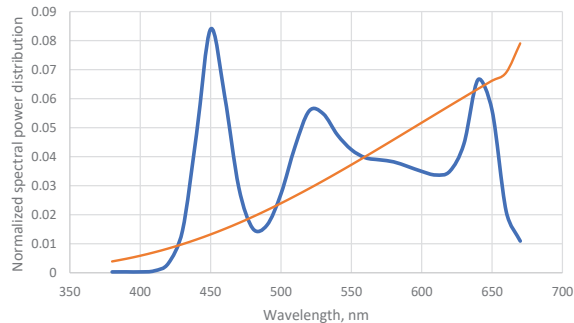

— Test Source — CIE Illuminant A - Tungsten

SSI Spectral Variance Graph- Daylight

SSI [CIE D65] 54

Spectral variance

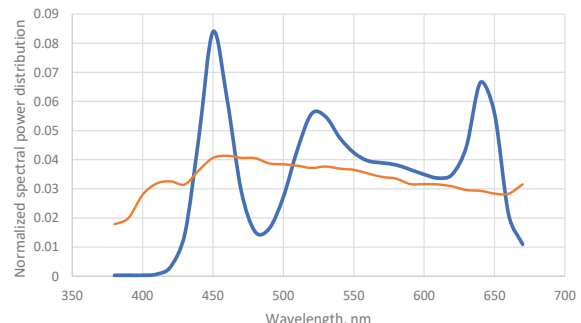

— Test Source — CIE Illuminant D65 - Daylight

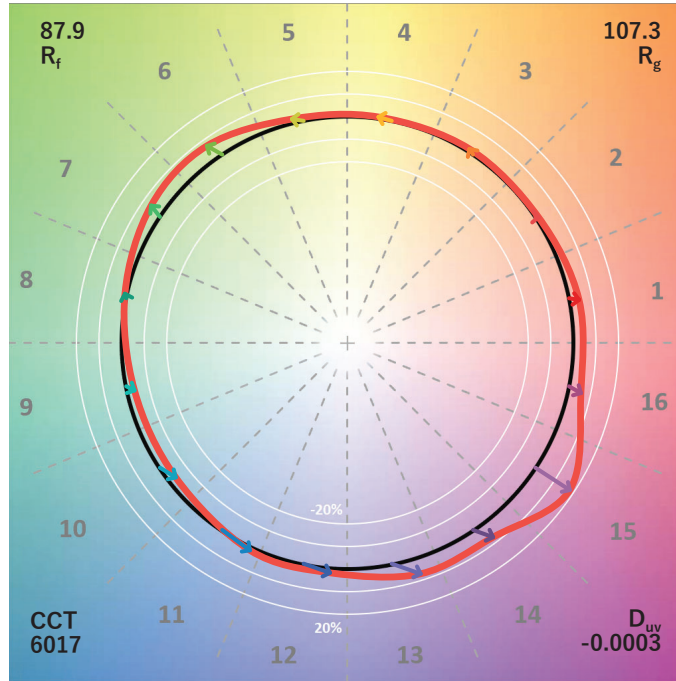

TM30-18 R_f Values per Hue Bin

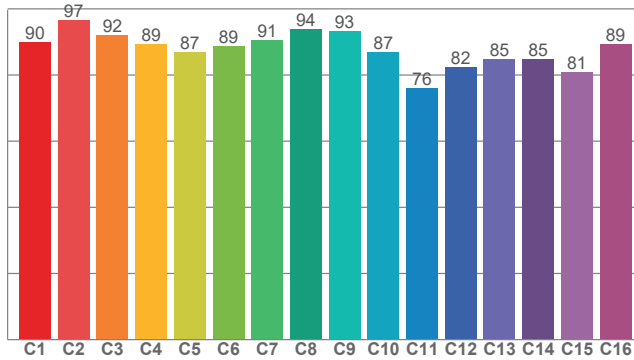

TM30 Chroma Shift per Hue Bin

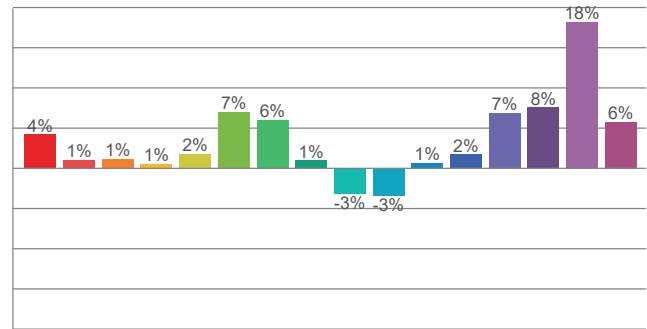

TM30-18 R_f Values per Reference Color (CES)

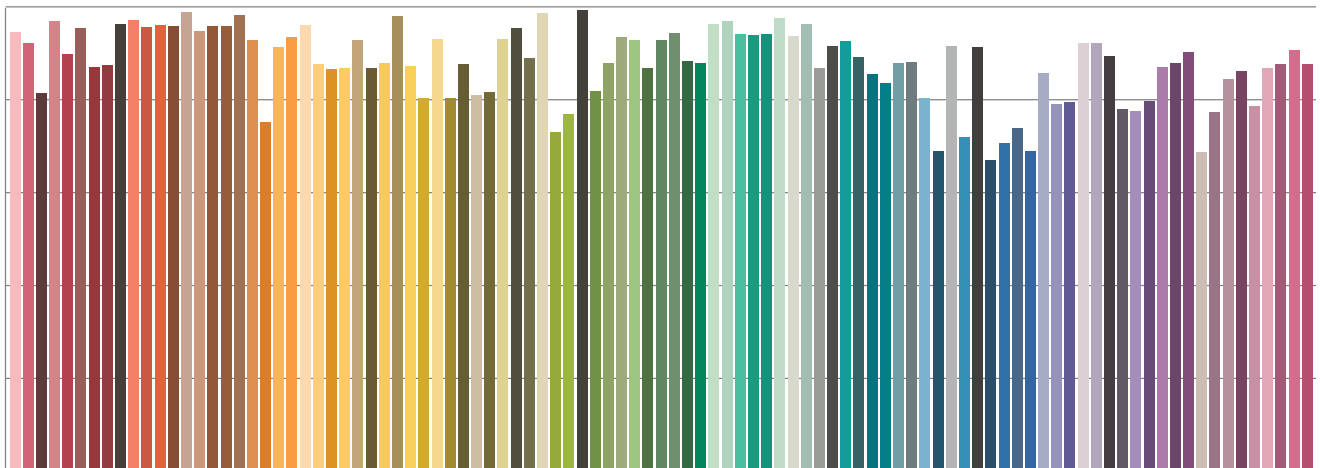

Color Temperature: 2473K

Accuracy Metric Overview

Color Rendering Index	Color Rendering Index, R9 (Red Component)	TM-30 Color Fidelity	TM-30 Color Gamut	Television Lighting Consistency Index	Color Quality Scale	Color Coordinate- CIE 1931	Color Coordinate- CIE 1931	Deviation from Black Body	SSI [CIE A] Tungsten	SSI [CIE D65] Daylight
CRI	CRI R9	TM30 R _f	TM30 R _g	TLCI	CQS	x	Y	Δuv	SSIt	SSId
89.5	54.7	92.9	105.6	92	89.3	0.483	0.419	0.0017	60	2

CIE 1931

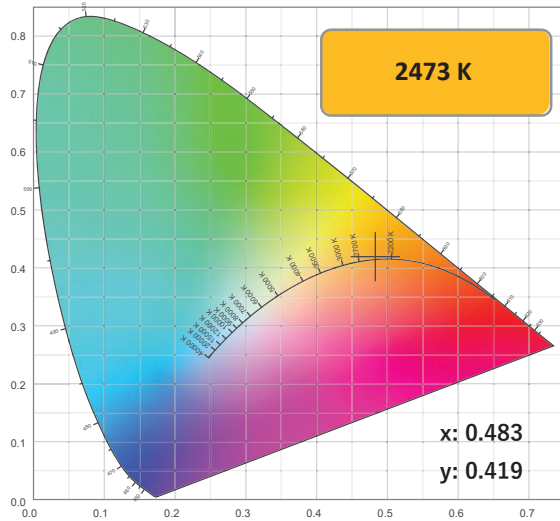

CIE 1931 ZOOMED

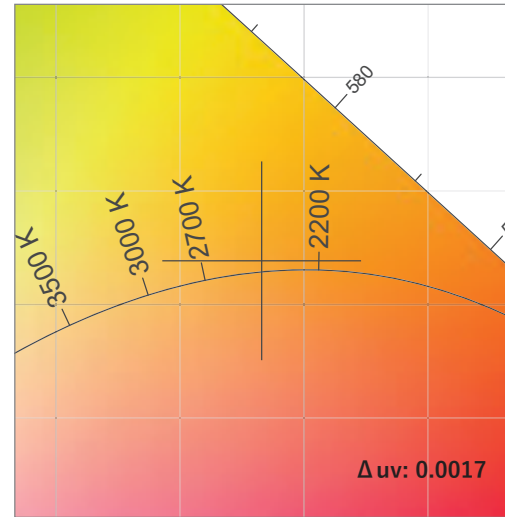

CRI: 89.5 (R1-R8)

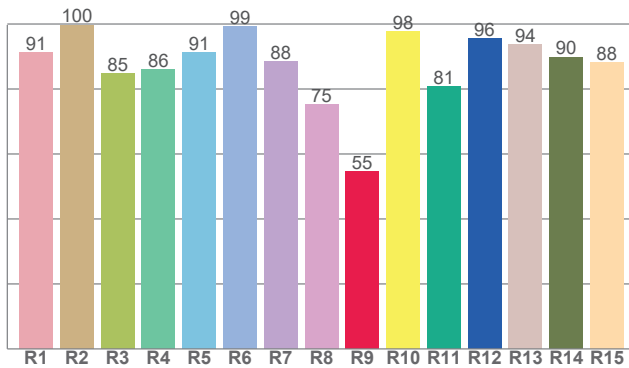

Spectral Power Distribution (SPD)

Dominant Wavelength 585 nm

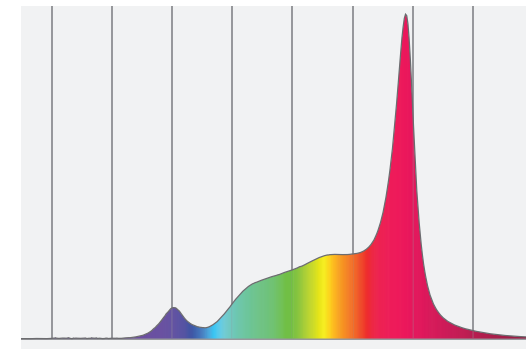

SSI Spectral Variance Graph- Tungsten

SSI [CIE A] 60

Spectral variance

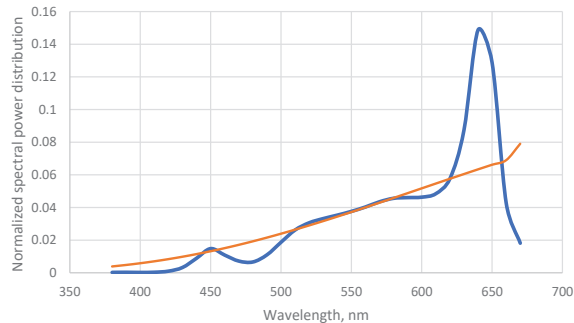

— Test Source — CIE Illuminant A - Tungsten

SSI Spectral Variance Graph- Daylight

SSI [CIE D65] 2

Spectral variance

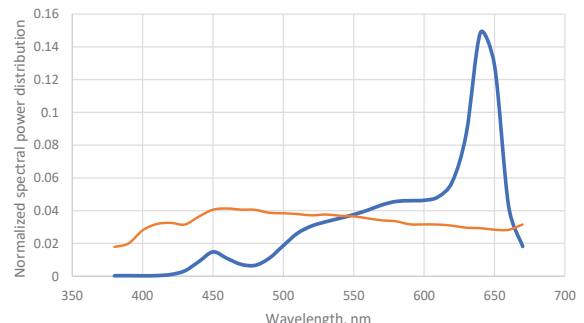

— Test Source — CIE Illuminant D65 - Daylight

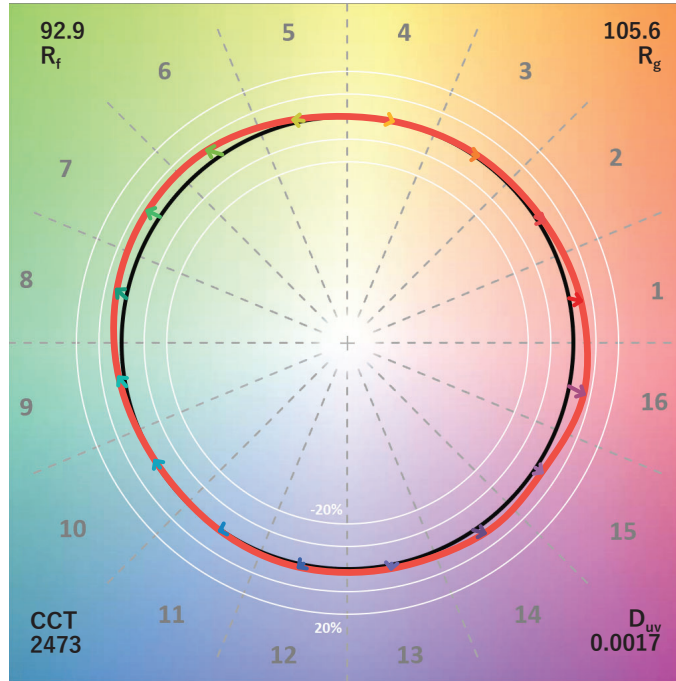

TM30-18 R_f Values per Hue Bin

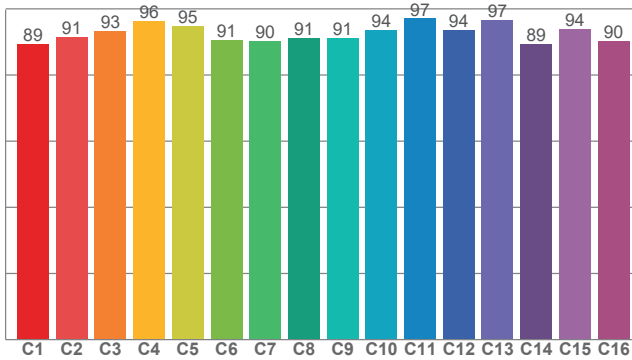

TM30 Chroma Shift per Hue Bin

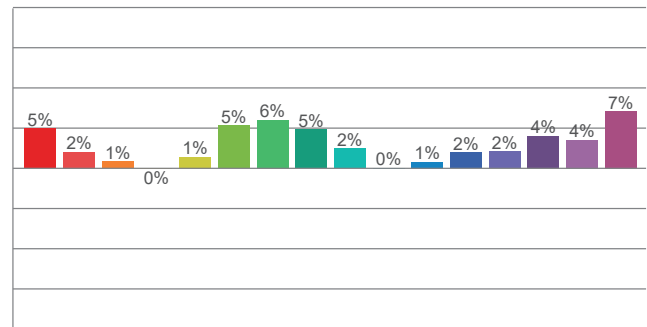

TM30-18 R_f Values per Reference Color (CES)

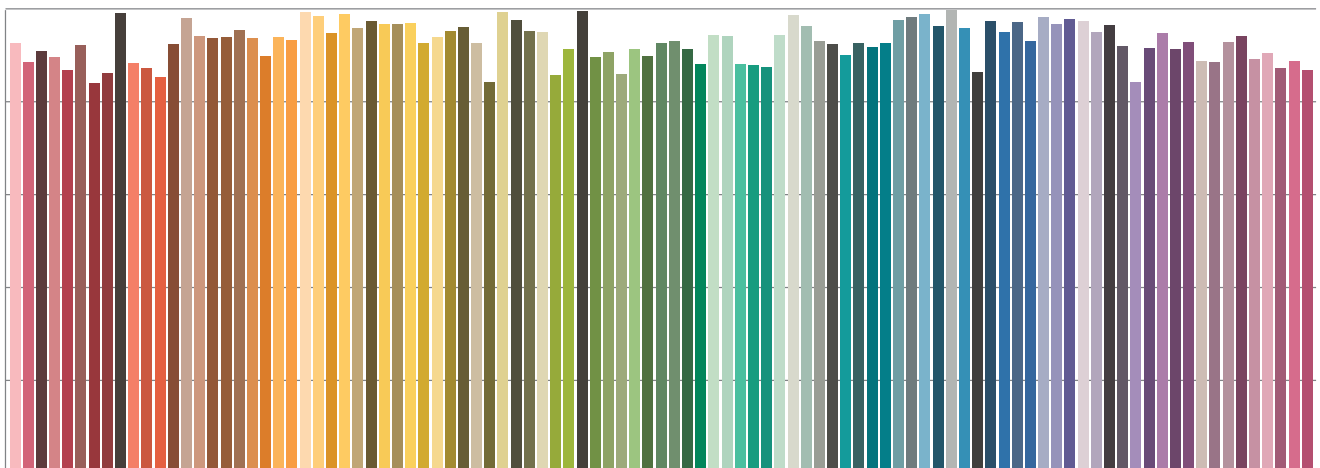

Color Temperature: 3256K

Accuracy Metric Overview

Color Rendering Index	Color Rendering Index, R9 (Red Component)	TM-30 Color Fidelity	TM-30 Color Gamut	Television Lighting Consistency Index	Color Quality Scale	Color Coordinate- CIE 1931	Color Coordinate- CIE 1931	Deviation from Black Body	SSI [CIE A] Tungsten	SSI [CIE D65] Daylight
CRI	CRI R9	TM30 R _f	TM30 R _g	TLCI	CQS	x	Y	Δuv	SSIt	SSId
90.3	60.2	91.6	106.7	92	92.7	0.421	0.399	0.0006	68	28

CIE 1931

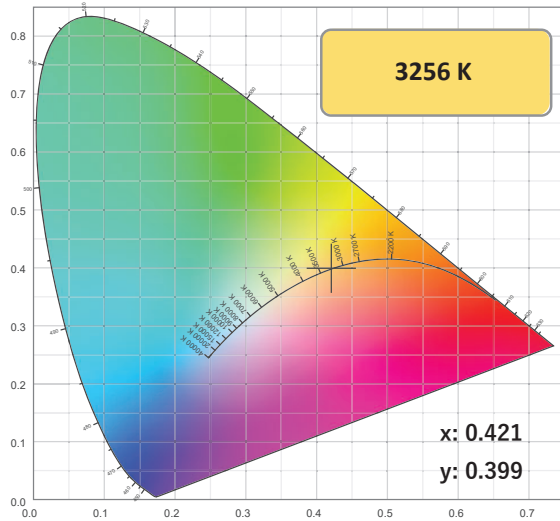

CIE 1931 ZOOMED

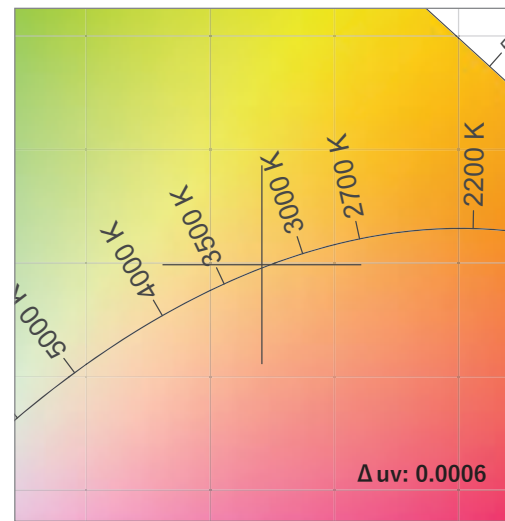

CRI: 90.3 (R1-R8)

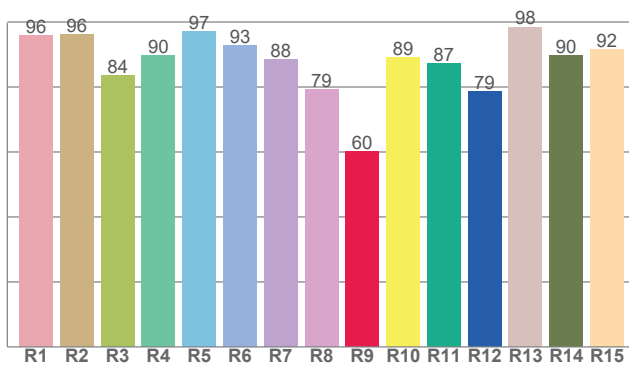

Spectral Power Distribution (SPD)

Dominant Wavelength 583 nm

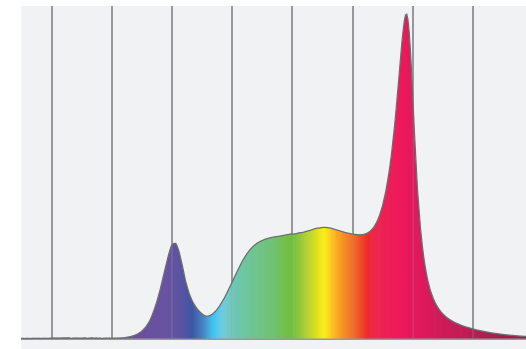

SSI Spectral Variance Graph- Tungsten

SSI [CIE A] 68

Spectral variance

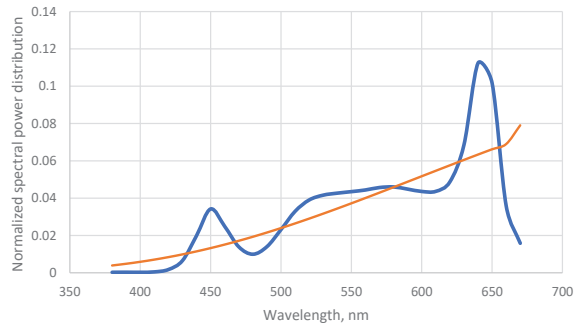

— Test Source — CIE Illuminant A - Tungsten

SSI Spectral Variance Graph- Daylight

SSI [CIE D65] 28

Spectral variance

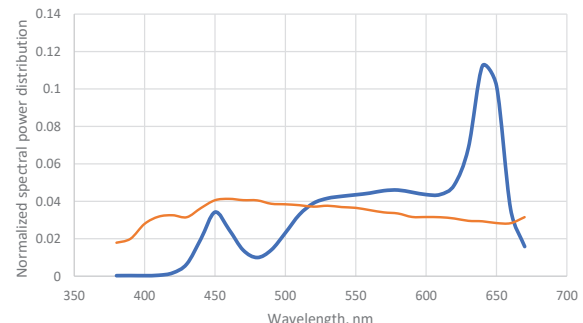

— Test Source — CIE Illuminant D65 - Daylight

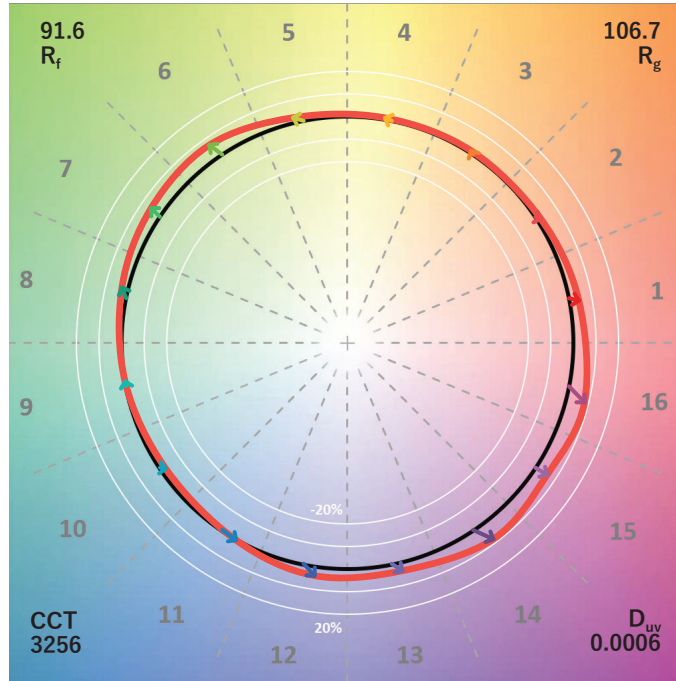

TM30-18 R_f Values per Hue Bin

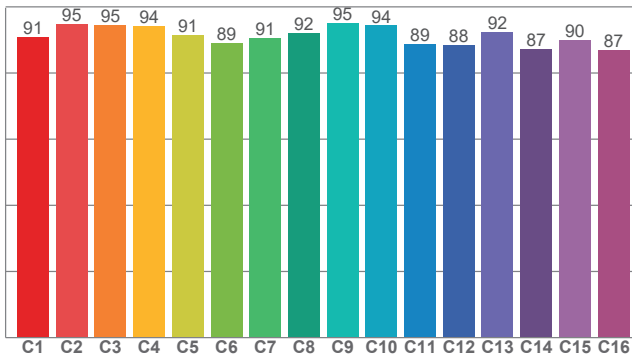

TM30 Chroma Shift per Hue Bin

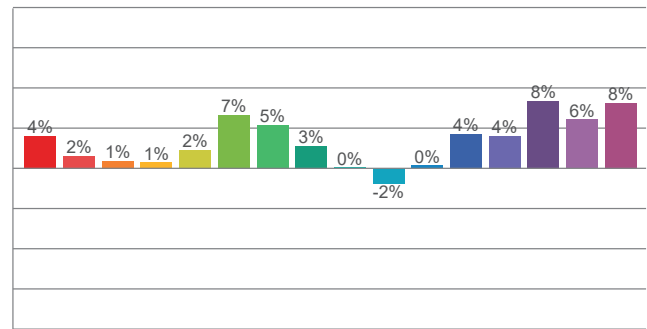

TM30-18 R_f Values per Reference Color (CES)

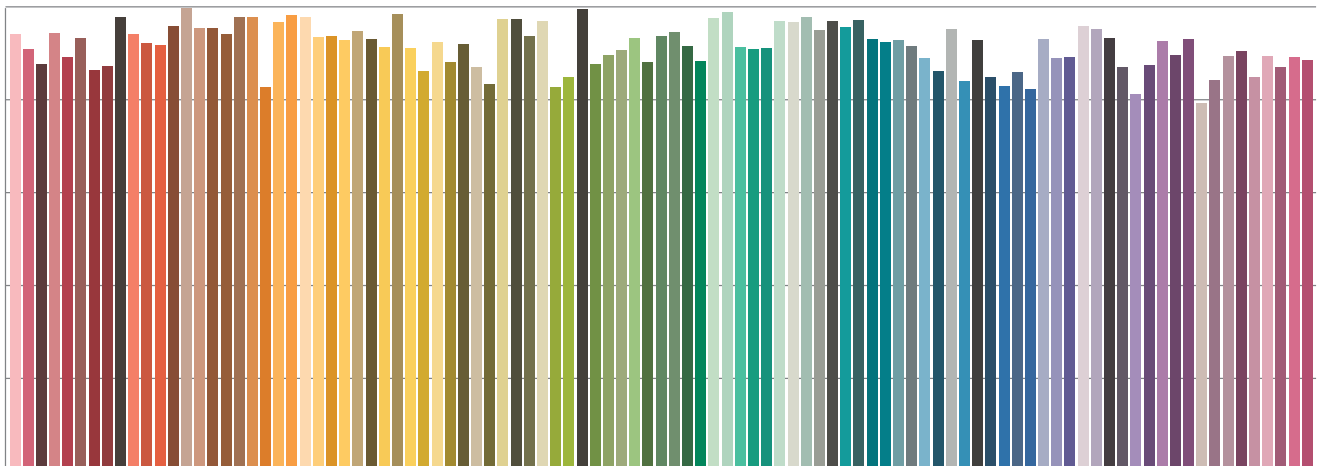

Color Temperature: 4546K

Accuracy Metric Overview

Color Rendering Index	Color Rendering Index, R9 (Red Component)	TM-30 Color Fidelity	TM-30 Color Gamut	Television Lighting Consistency Index	Color Quality Scale	Color Coordinate- CIE 1931	Color Coordinate- CIE 1931	Deviation from Black Body	SSI [CIE A] Tungsten	SSI [CIE D65] Daylight
CRI	CRI R9	TM30 R _f	TM30 R _g	TLCI	CQS	x	Y	Δuv	SSIt	SSId
86.3	35.2	88.6	109.4	87	91.8	0.359	0.362	-0.0002	50	44

CIE 1931

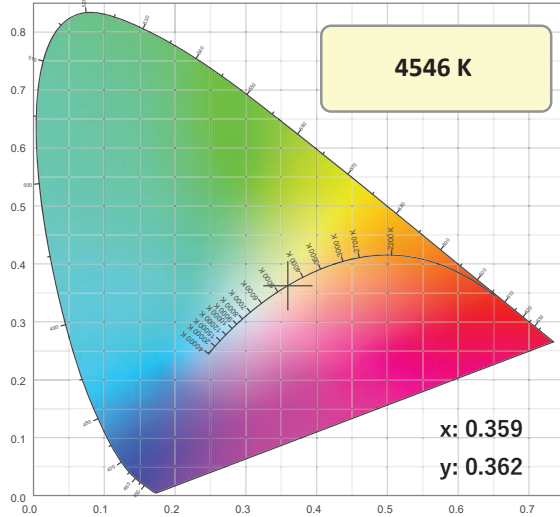

CIE 1931 ZOOMED

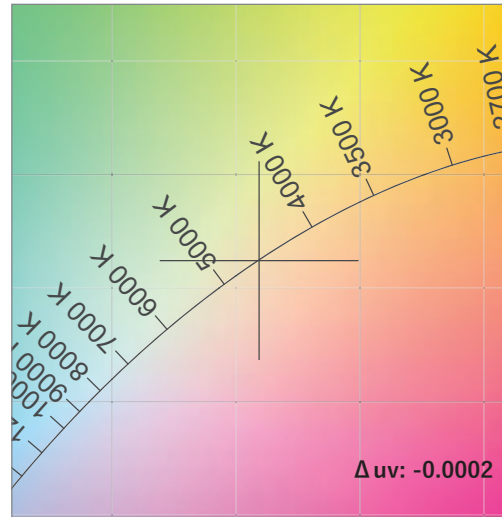

CRI: 86.3 (R1-R8)

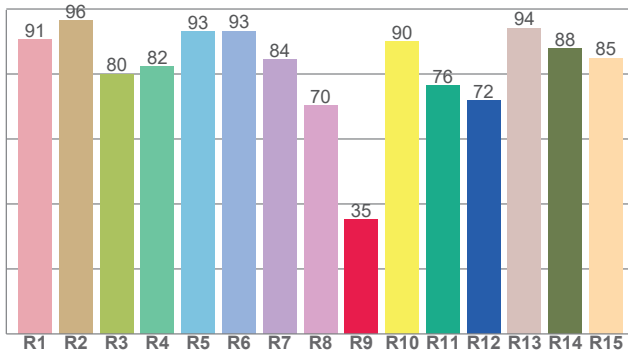

Spectral Power Distribution (SPD)

Dominant Wavelength 581 nm

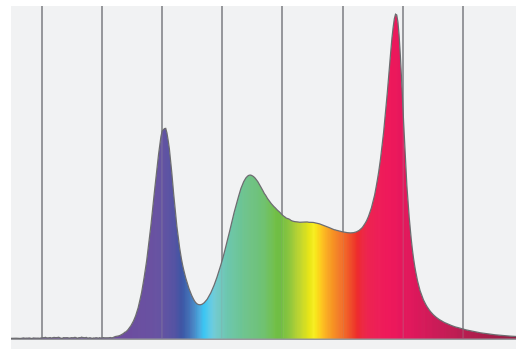

SSI Spectral Variance Graph- Tungsten

SSI [CIE A] 50

Spectral variance

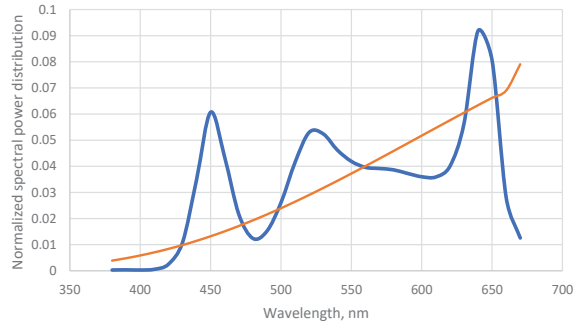

— Test Source — CIE Illuminant A - Tungsten

SSI Spectral Variance Graph- Daylight

SSI [CIE D65] 44

Spectral variance

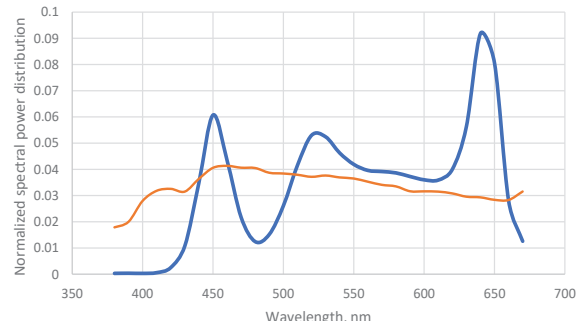

— Test Source — CIE Illuminant D65 - Daylight

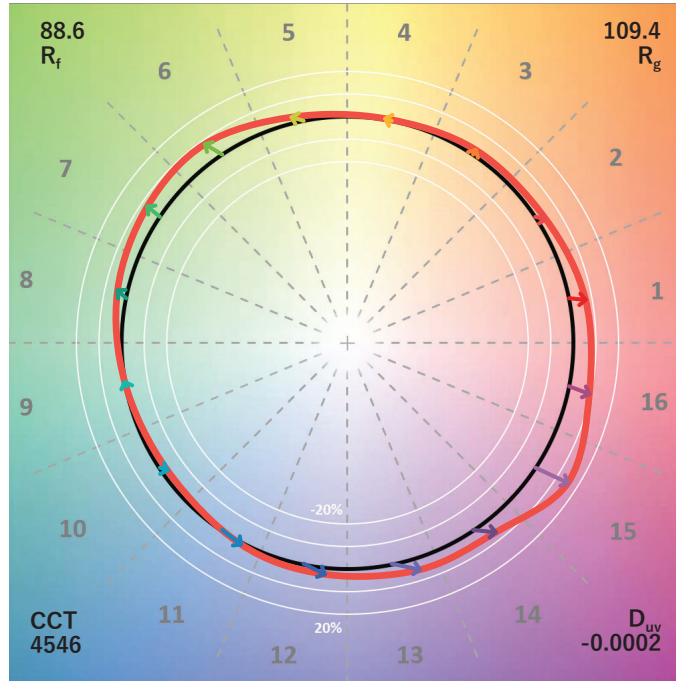

TM30-18 R_f Values per Hue Bin

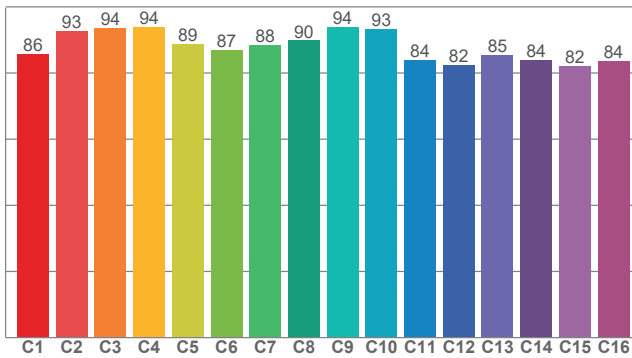

TM30 Chroma Shift per Hue Bin

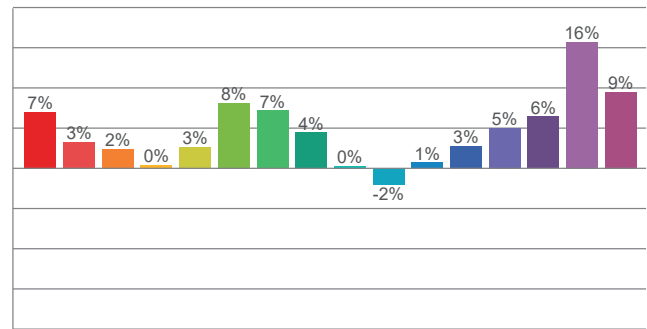

TM30-18 R_f Values per Reference Color (CES)

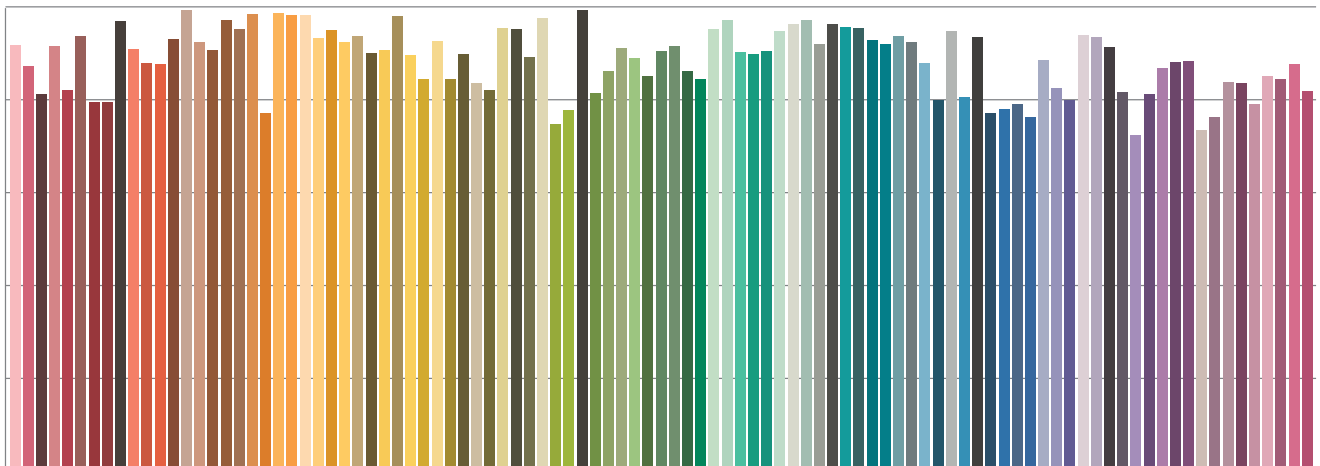

Color Temperature: 5627K

Accuracy Metric Overview

Color Rendering Index	Color Rendering Index, R9 (Red Component)	TM-30 Color Fidelity	TM-30 Color Gamut	Television Lighting Consistency Index	Color Quality Scale	Color Coordinate- CIE 1931	Color Coordinate- CIE 1931	Deviation from Black Body	SSI [CIE A] Tungsten	SSI [CIE D65] Daylight
CRI	CRI R9	TM30 R _f	TM30 R _g	TLCI	CQS	x	Y	Δuv	SSIt	SSId
87.8	53.3	88.0	108.2	89	91.1	0.330	0.338	-0.0003	35	52

CIE 1931

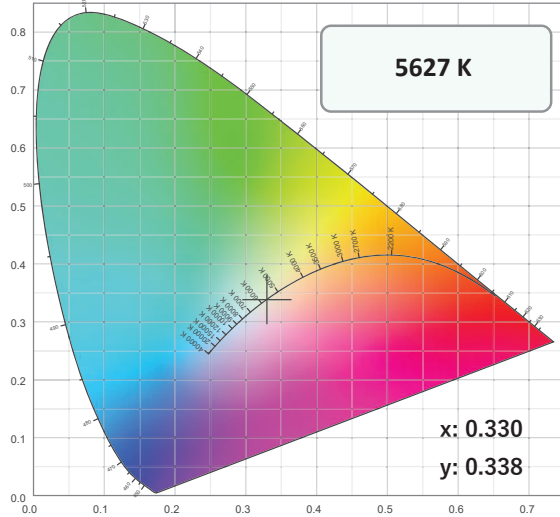

CIE 1931 ZOOMED

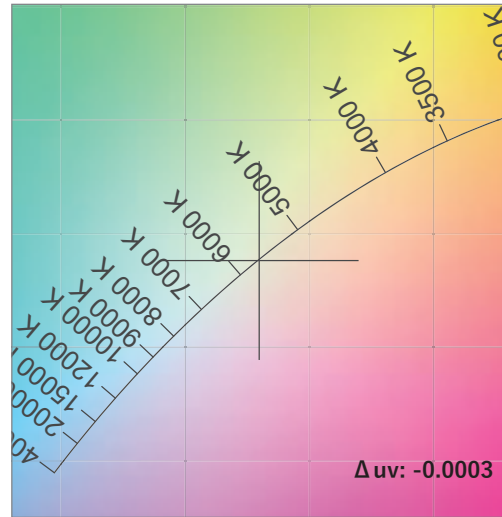

CRI: 87.8 (R1-R8)

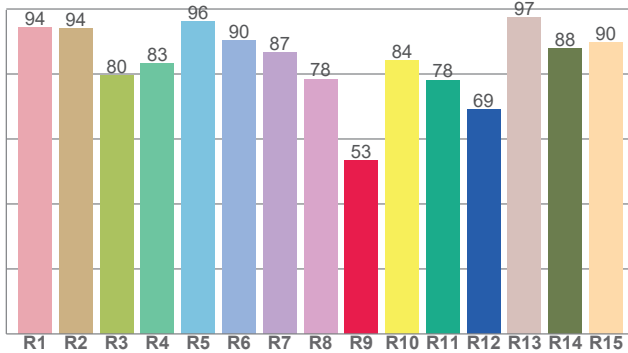

Spectral Power Distribution (SPD)

Dominant Wavelength 585 nm

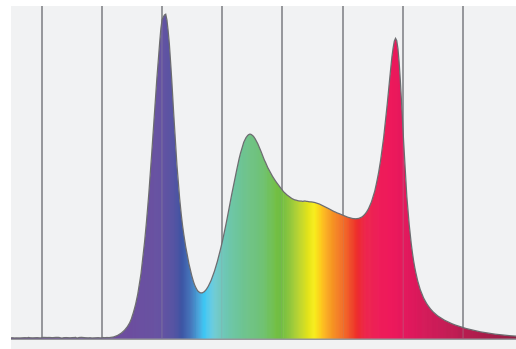

SSI Spectral Variance Graph- Tungsten

SSI [CIE A] 35

Spectral variance

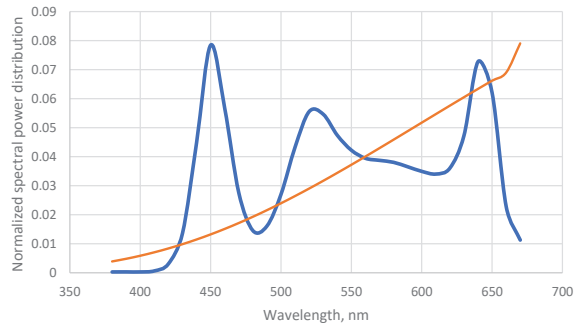

— Test Source — CIE Illuminant A - Tungsten

SSI Spectral Variance Graph- Daylight

SSI [CIE D65] 52

Spectral variance

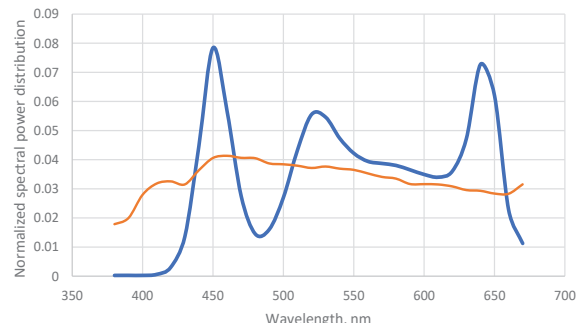

— Test Source — CIE Illuminant D65 - Daylight

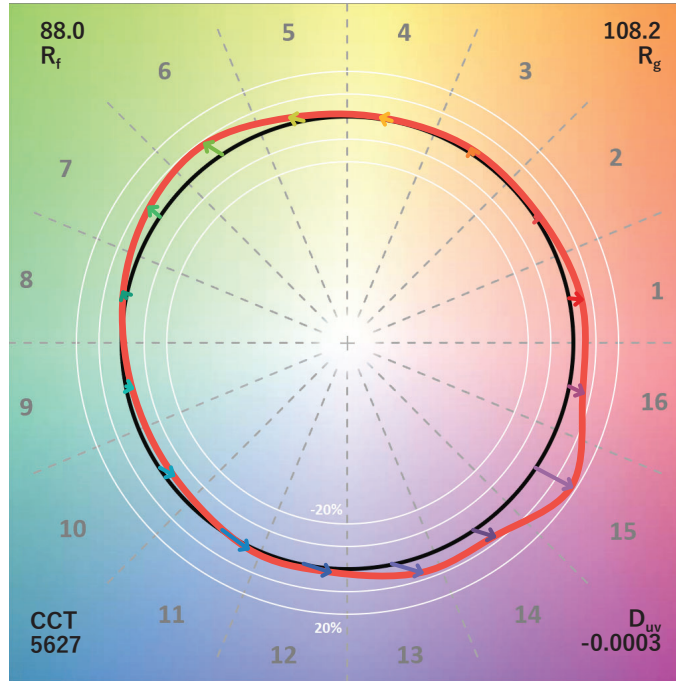

TM30-18 R_f Values per Hue Bin

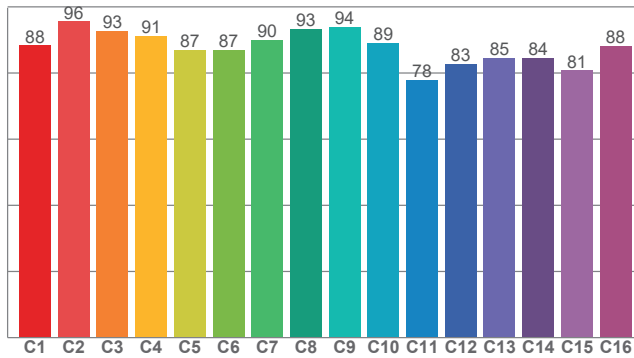

TM30 Chroma Shift per Hue Bin

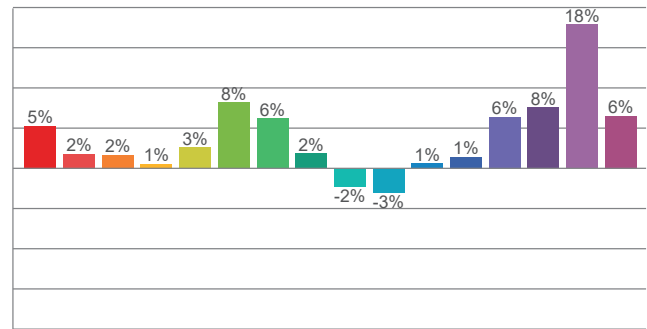

TM30-18 R_f Values per Reference Color (CES)

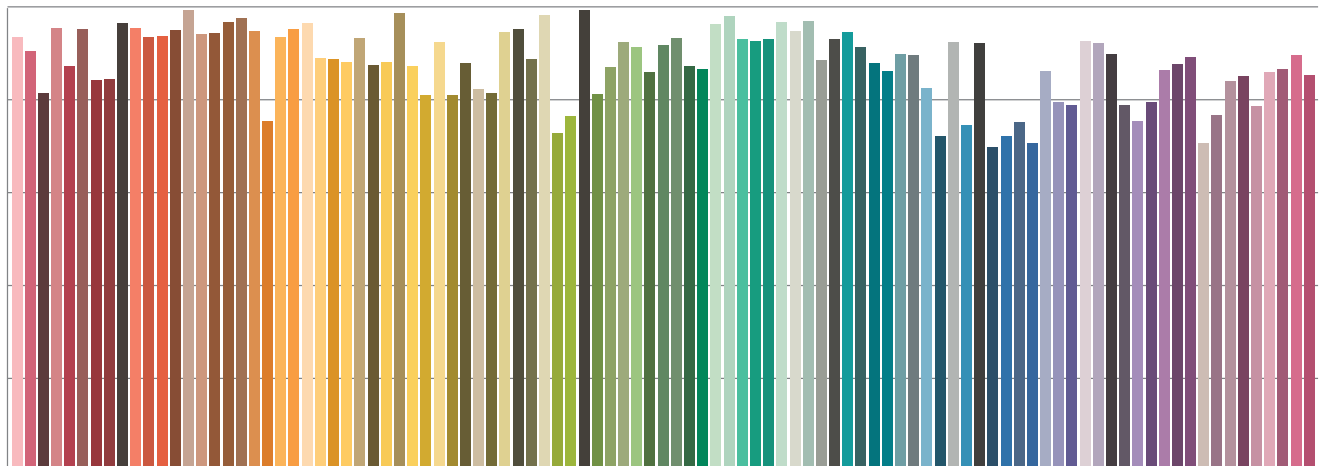

Color Temperature: 6027K

Accuracy Metric Overview

Color Rendering Index	Color Rendering Index, R9 (Red Component)	TM-30 Color Fidelity	TM-30 Color Gamut	Television Lighting Consistency Index	Color Quality Scale	Color Coordinate- CIE 1931	Color Coordinate- CIE 1931	Deviation from Black Body	SSI [CIE A] Tungsten	SSI [CIE D65] Daylight
CRI	CRI R9	TM30 R _f	TM30 R _g	TLCI	CQS	x	Y	Δuv	SSIt	SSId
88.9	62.7	88.0	107.3	90	90.7	0.322	0.331	-0.0002	30	54

CIE 1931

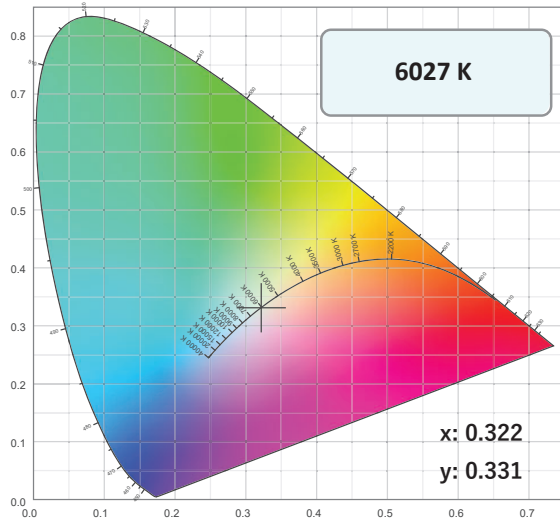

CIE 1931 ZOOMED

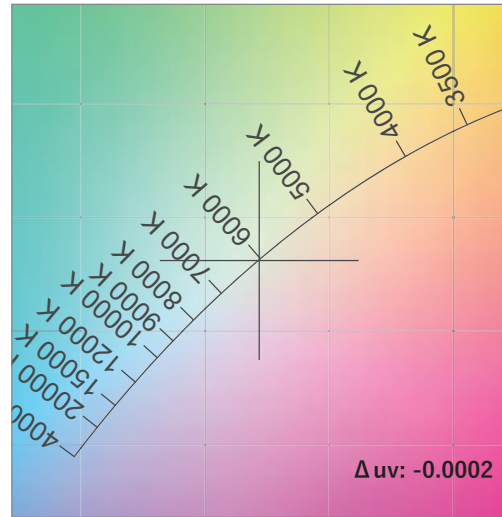

CRI: 88.9 (R1-R8)

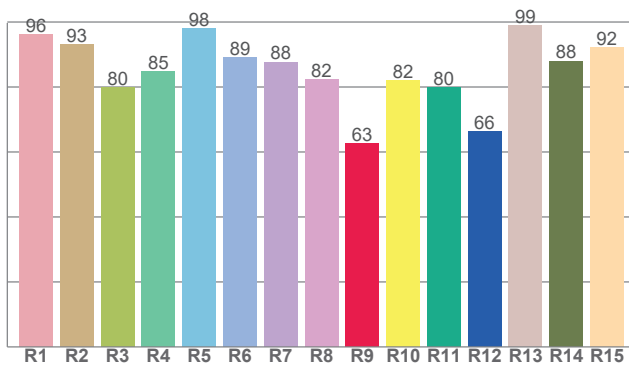

Spectral Power Distribution (SPD)

Dominant Wavelength 595 nm

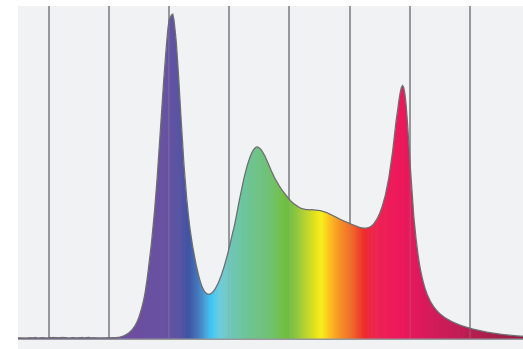

SSI Spectral Variance Graph- Tungsten

SSI [CIE A] 30

Spectral variance

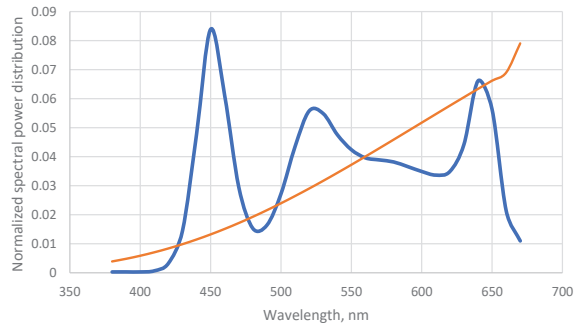

— Test Source — CIE Illuminant A - Tungsten

SSI Spectral Variance Graph- Daylight

SSI [CIE D65] 54

Spectral variance

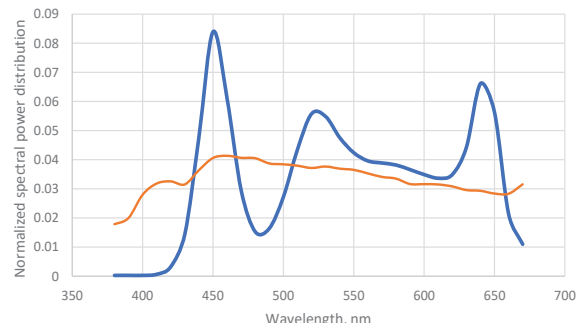

— Test Source — CIE Illuminant D65 - Daylight

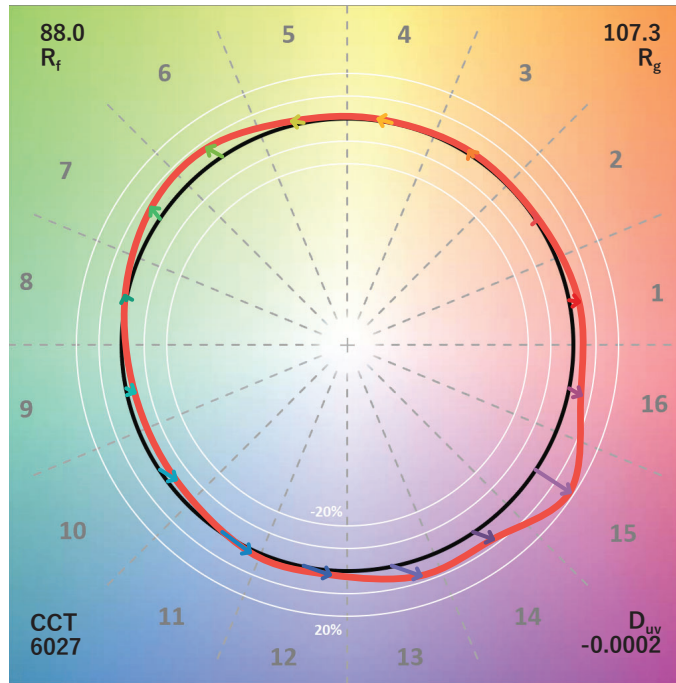

TM30-18 R_f Values per Hue Bin

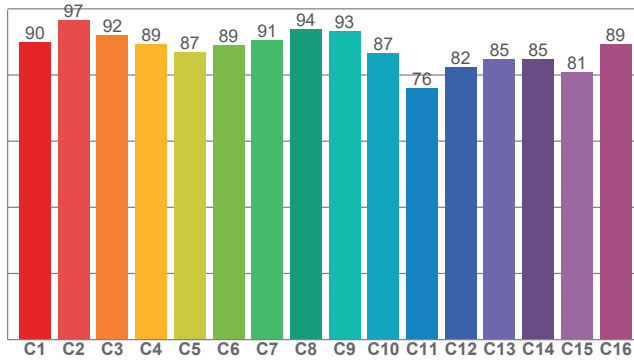

TM30 Chroma Shift per Hue Bin

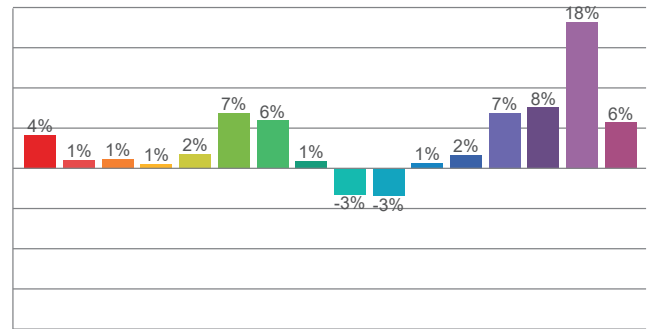

TM30-18 R_f Values per Reference Color (CES)

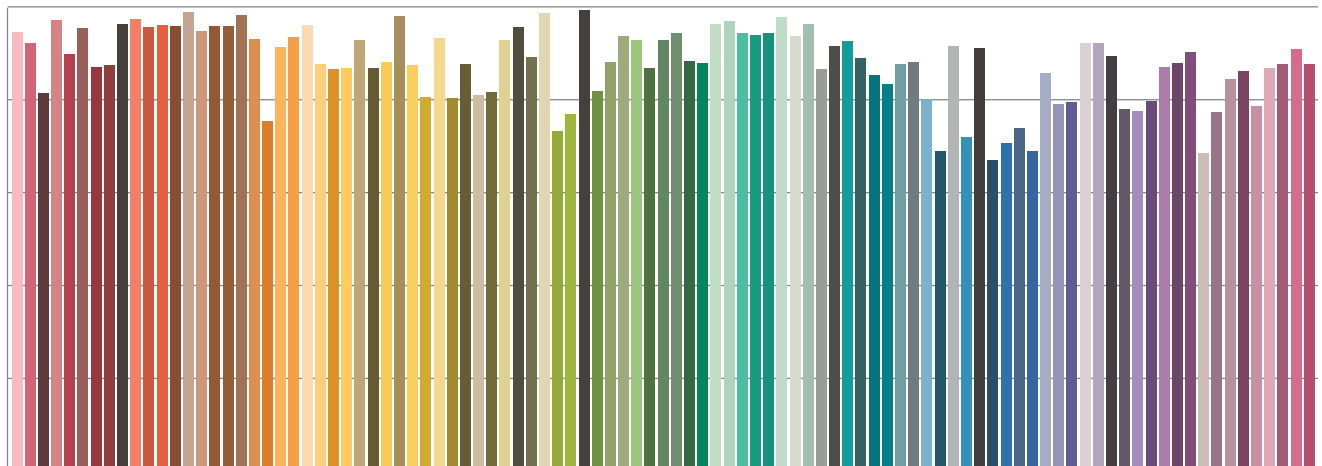

Color Temperature: 6500K

Accuracy Metric Overview

Color Rendering Index	Color Rendering Index, R9 (Red Component)	TM-30 Color Fidelity	TM-30 Color Gamut	Television Lighting Consistency Index	Color Quality Scale	Color Coordinate- CIE 1931	Color Coordinate- CIE 1931	Deviation from Black Body	SSI [CIE A] Tungsten	SSI [CIE D65] Daylight
CRI	CRI R9	TM30 R _f	TM30 R _g	TLCI	CQS	x	Y	Δuv	SSIt	SSId
89.7	72.6	87.7	106.2	91	90.1	0.314	0.323	-0.0003	24	55

CIE 1931

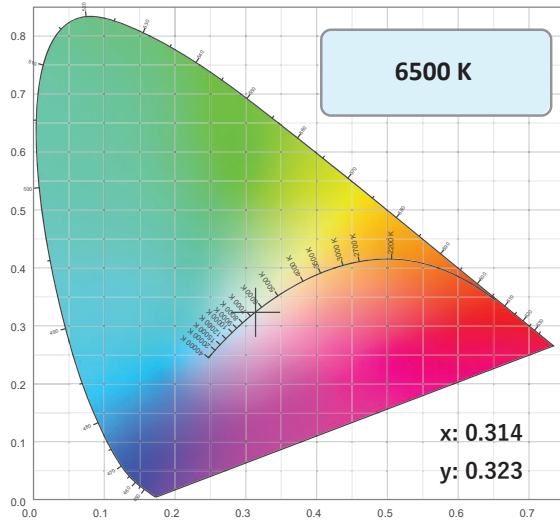

CIE 1931 ZOOMED

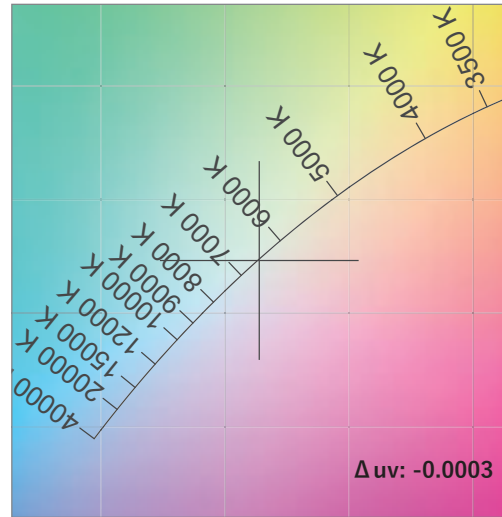

CRI: 89.7 (R1-R8)

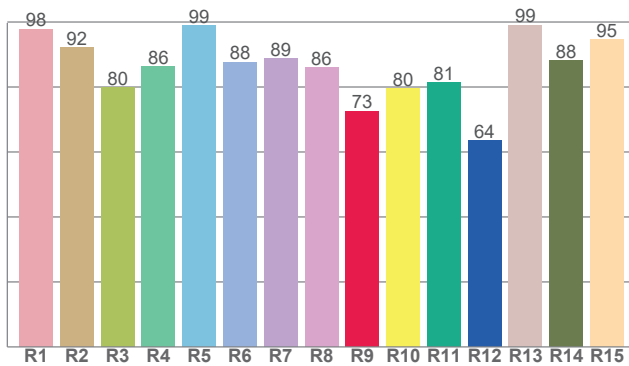

Spectral Power Distribution (SPD)

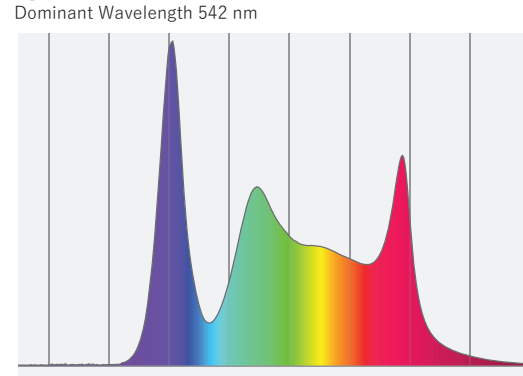

SSI Spectral Variance Graph- Tungsten

SSI [CIE A] 24

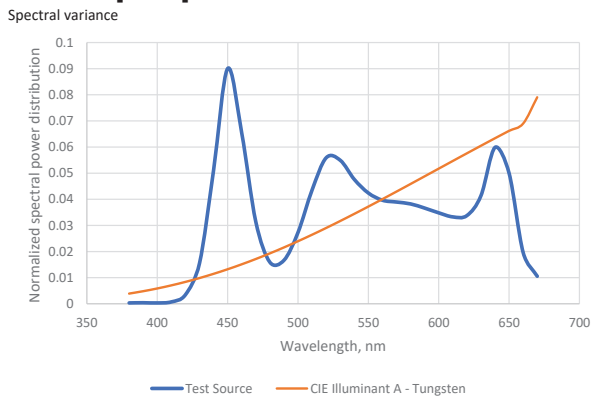

SSI Spectral Variance Graph- Daylight

SSI [CIE D65] 55

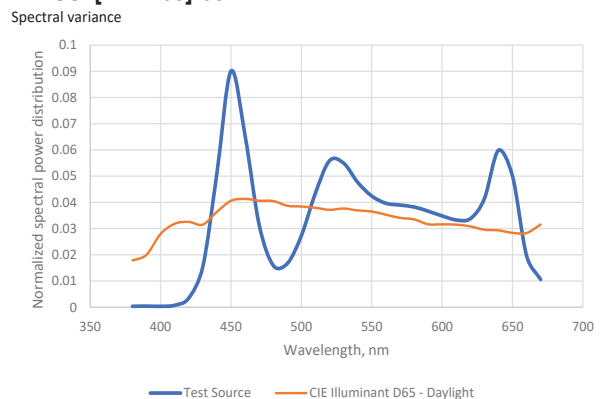

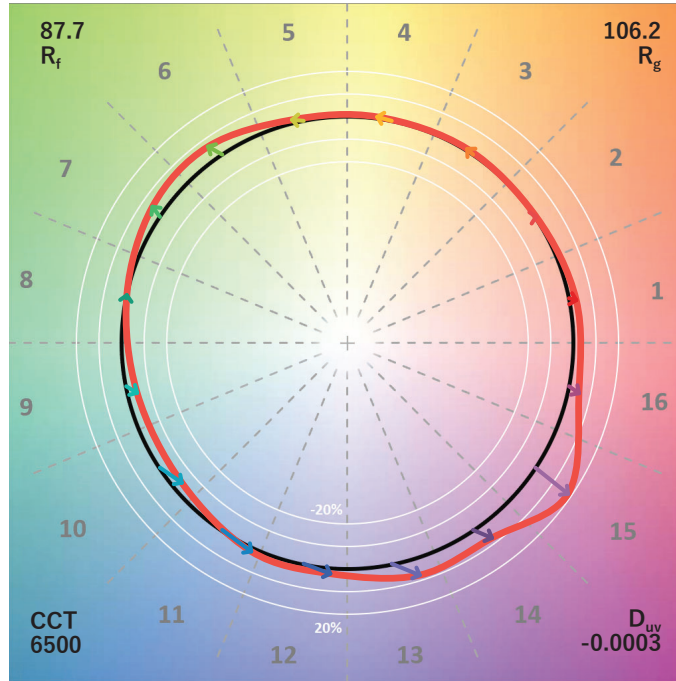

TM30-18 R_f Values per Hue Bin

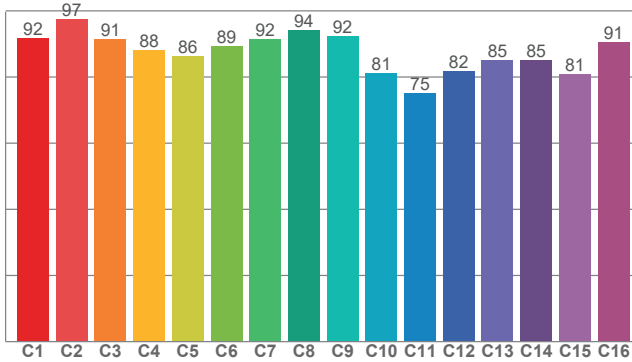

TM30 Chroma Shift per Hue Bin

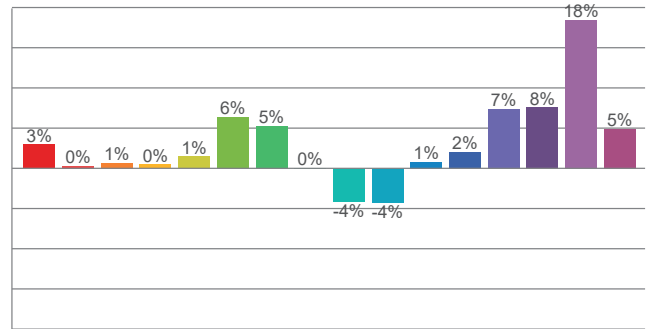

TM30-18 R_f Values per Reference Color (CES)

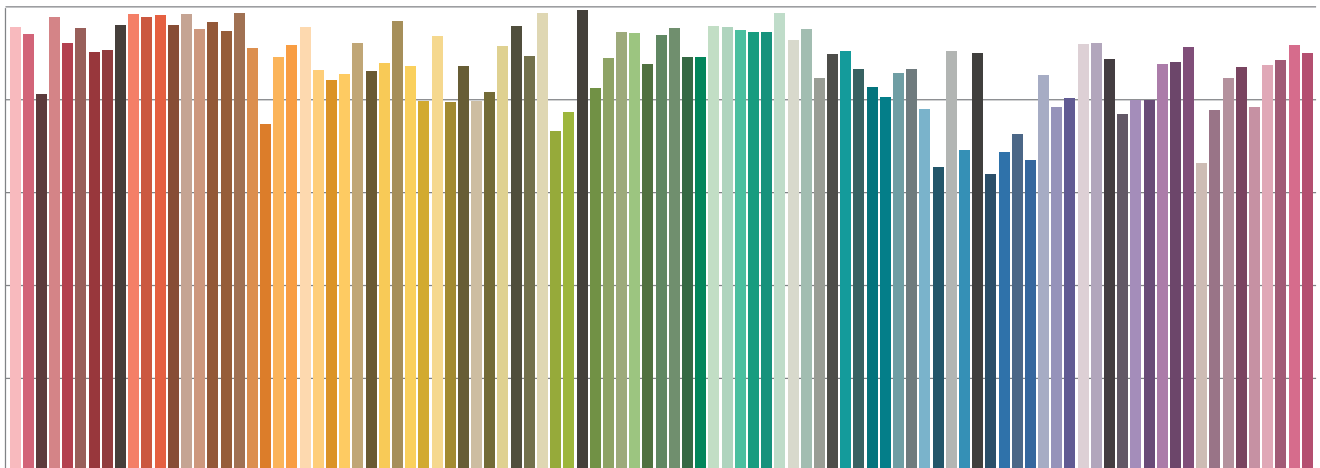

Color Temperature: 7514K

Accuracy Metric Overview

Color Rendering Index	Color Rendering Index, R9 (Red Component)	TM-30 Color Fidelity	TM-30 Color Gamut	Television Lighting Consistency Index	Color Quality Scale	Color Coordinate- CIE 1931	Color Coordinate- CIE 1931	Deviation from Black Body	SSI [CIE A] Tungsten	SSI [CIE D65] Daylight
CRI	CRI R9	TM30 R _f	TM30 R _g	TLCI	CQS	x	Y	Δuv	SSIt	SSId
90.2	89.7	87.0	104.3	91	88.9	0.300	0.310	-0.0005	14	54

CIE 1931

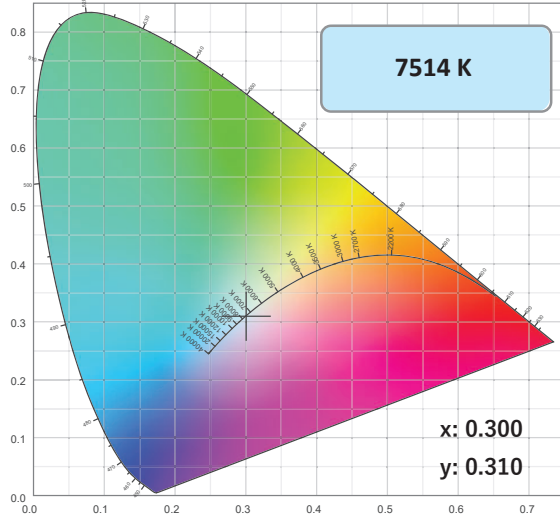

CIE 1931 ZOOMED

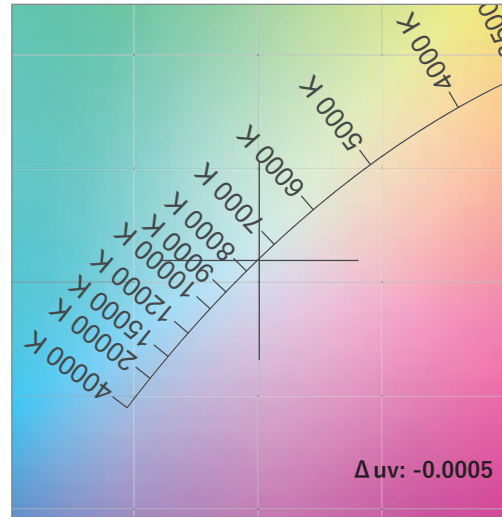

CRI: 90.2 (R1-R8)

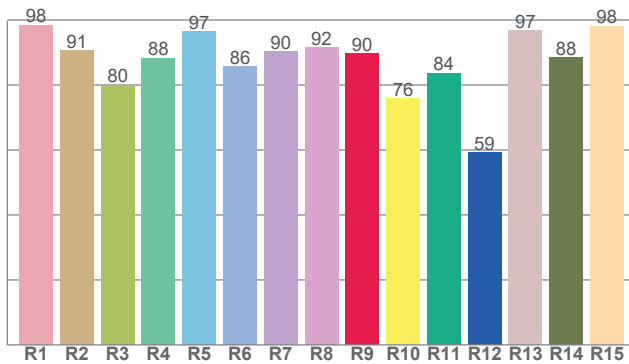

Spectral Power Distribution (SPD)

Dominant Wavelength 466 nm

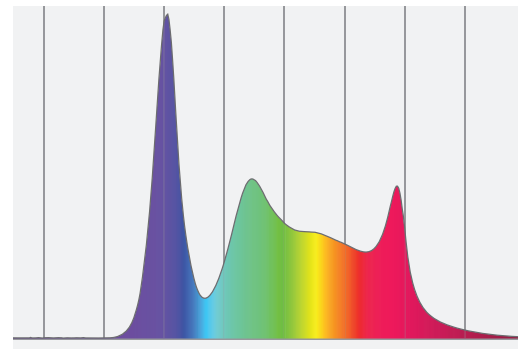

SSI Spectral Variance Graph- Tungsten

SSI [CIE A] 14

Spectral variance

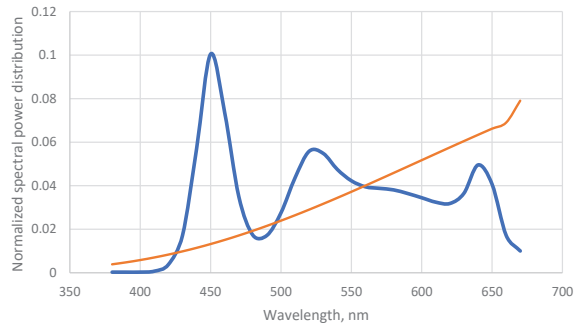

— Test Source — CIE Illuminant A - Tungsten

SSI Spectral Variance Graph- Daylight

SSI [CIE D65] 54

Spectral variance

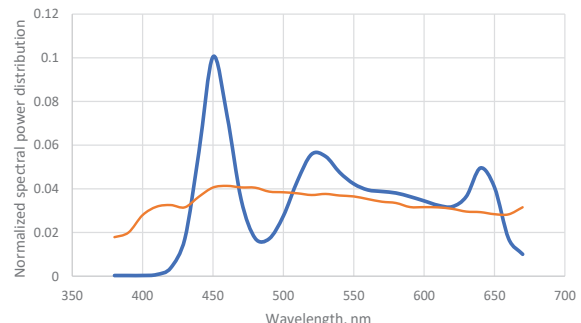

— Test Source — CIE Illuminant D65 - Daylight

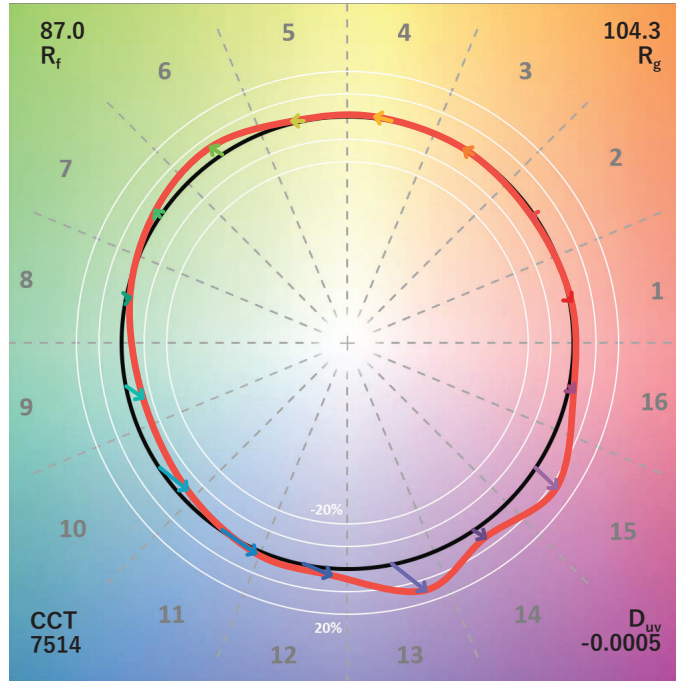

TM30-18 R_f Values per Hue Bin

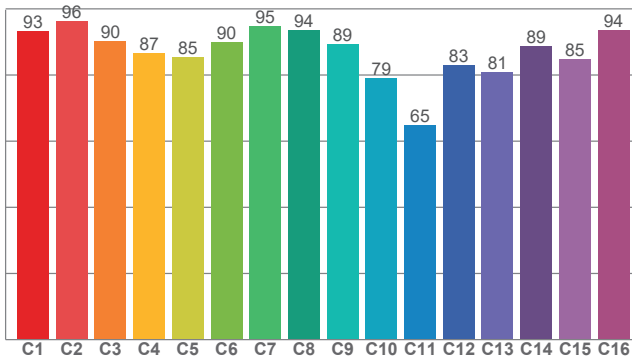

TM30 Chroma Shift per Hue Bin

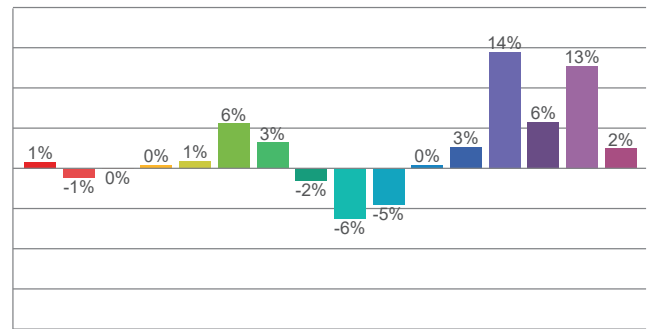

TM30-18 R_f Values per Reference Color (CES)

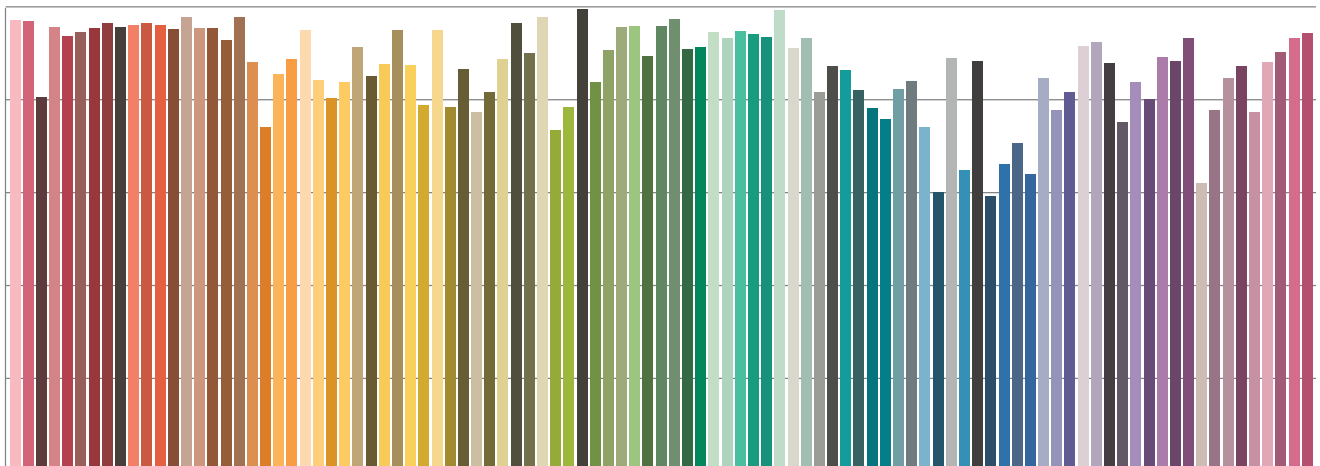

Color Temperature: 8491K

Accuracy Metric Overview

Color Rendering Index	Color Rendering Index, R9 (Red Component)	TM-30 Color Fidelity	TM-30 Color Gamut	Television Lighting Consistency Index	Color Quality Scale	Color Coordinate- CIE 1931	Color Coordinate- CIE 1931	Deviation from Black Body	SSI [CIE A] Tungsten	SSI [CIE D65] Daylight
CRI	CRI R9	TM30 R _f	TM30 R _g	TLCI	CQS	x	Y	Δuv	SSIt	SSId
89.9	95.9	86.1	102.5	90	87.6	0.291	0.299	-0.0005	7	52

CIE 1931

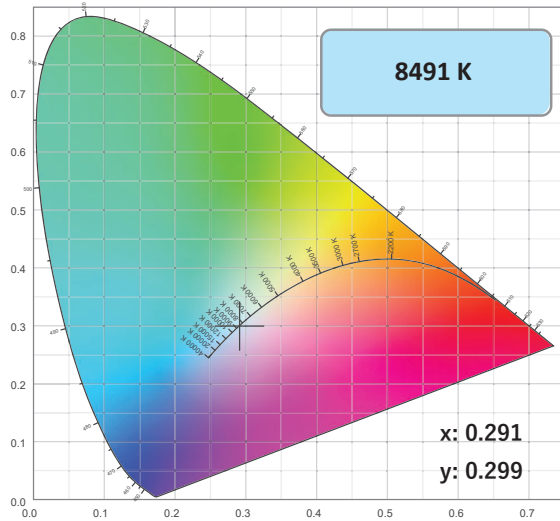

CIE 1931 ZOOMED

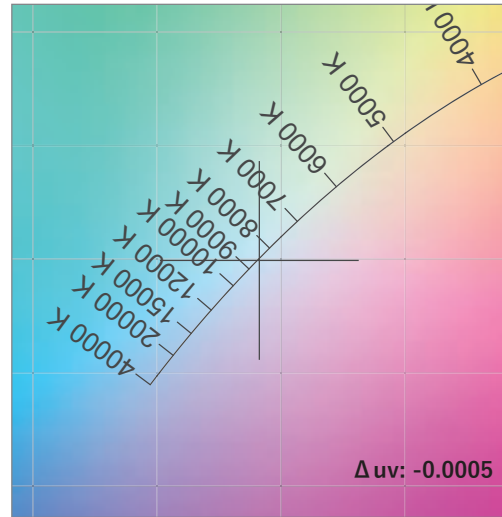

CRI: 89.9 (R1-R8)

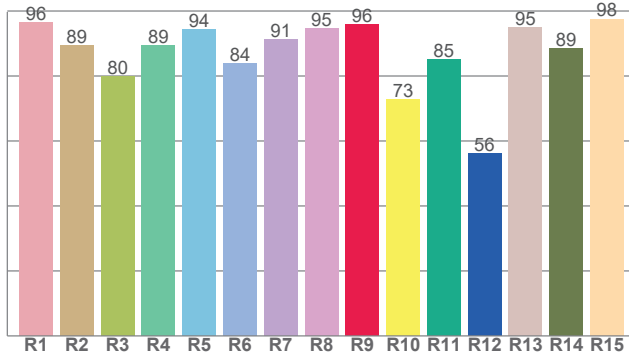

Spectral Power Distribution (SPD)

Dominant Wavelength 471 nm

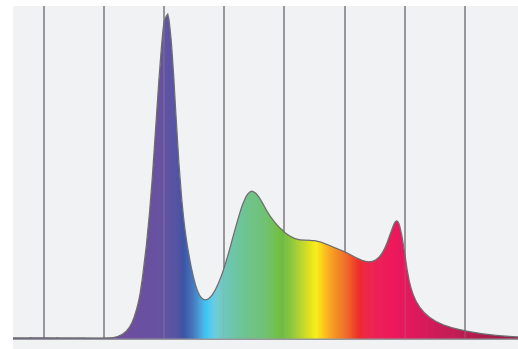

SSI Spectral Variance Graph- Tungsten

SSI [CIE A] 7

Spectral variance

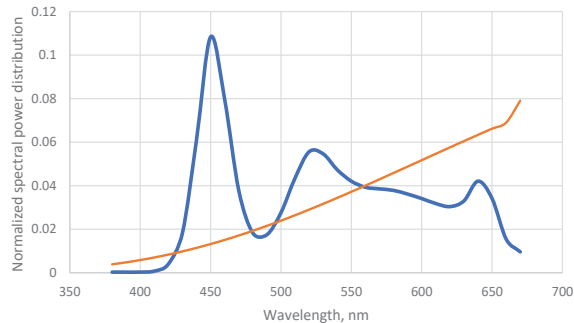

— Test Source — CIE Illuminant A - Tungsten

SSI Spectral Variance Graph- Daylight

SSI [CIE D65] 52

Spectral variance

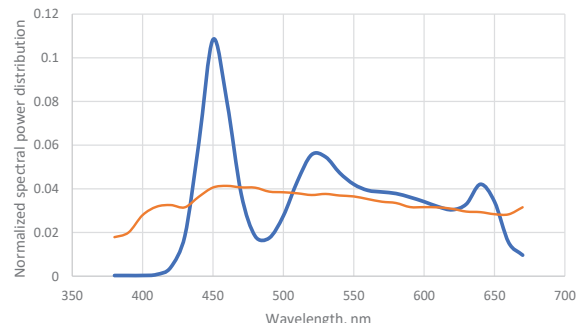

— Test Source — CIE Illuminant D65 - Daylight

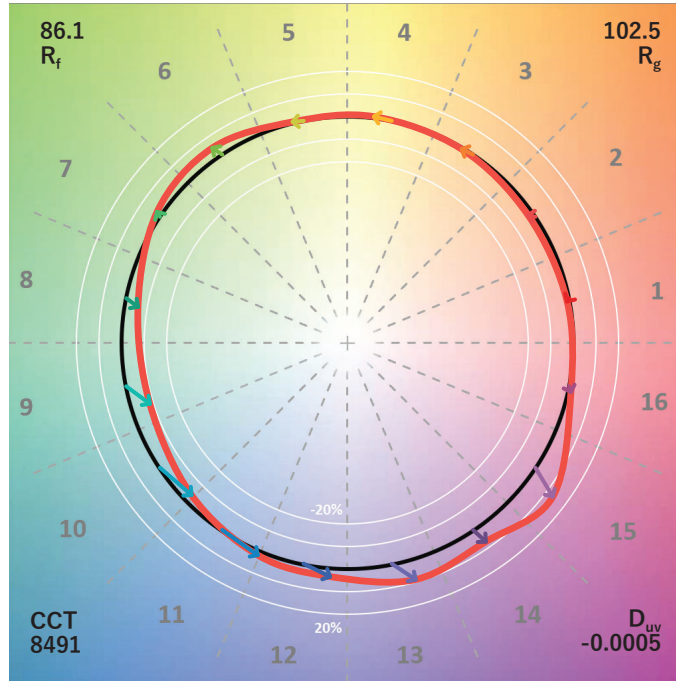

TM30-18 R_f Values per Hue Bin

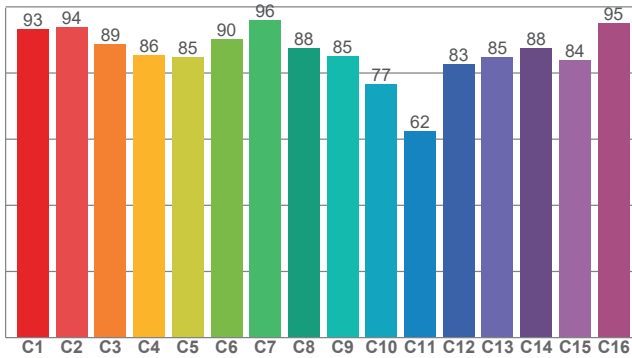

TM30 Chroma Shift per Hue Bin

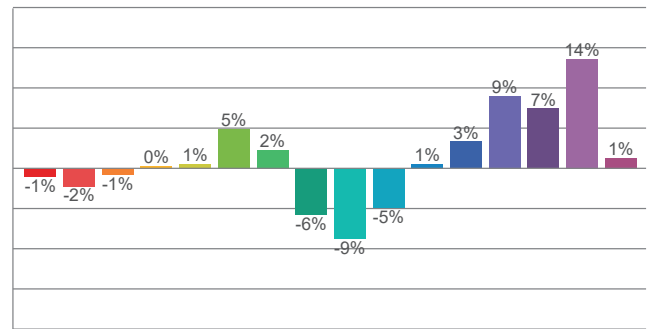

TM30-18 R_f Values per Reference Color (CES)

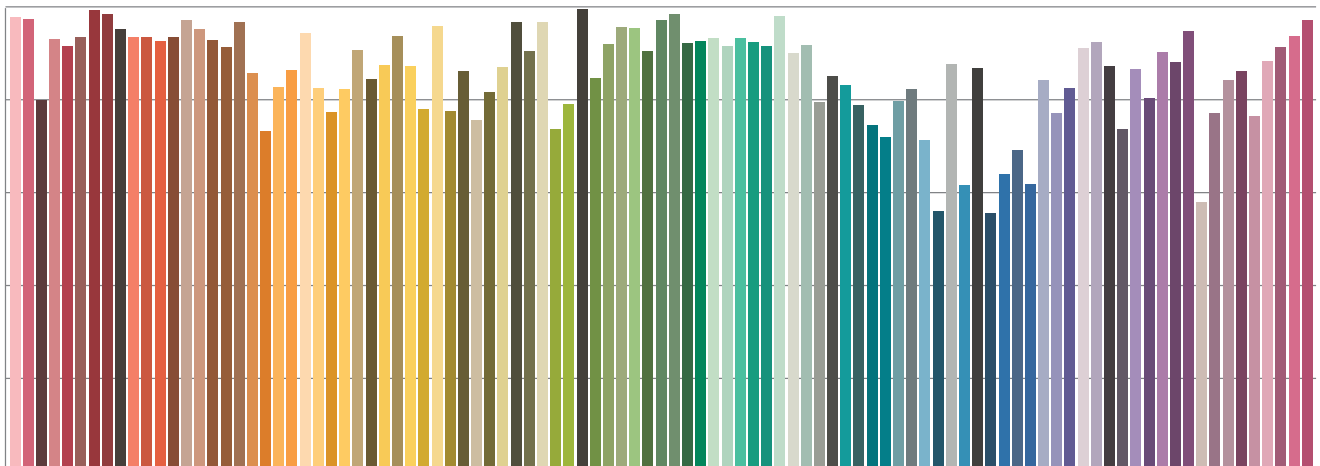

Measurements

Total Lumen Output: 766 lm
 Peak Intensity: 3695 cd
 Efficacy: 20 Lumen/Watt
 Power: 38.5 W
 Voltage: 120 V, Current: 0.321 A

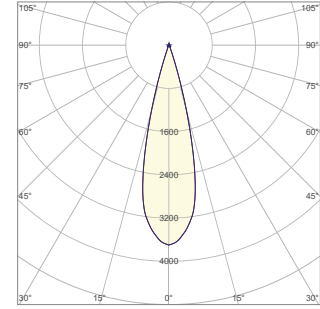

Spectral Power Distribution

Dominant Wavelength 629 nm

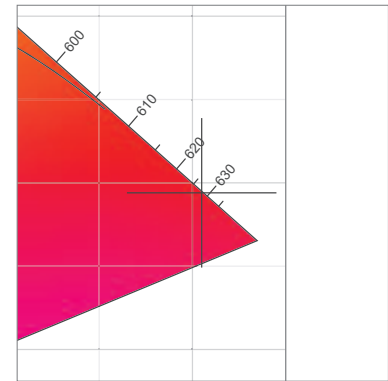
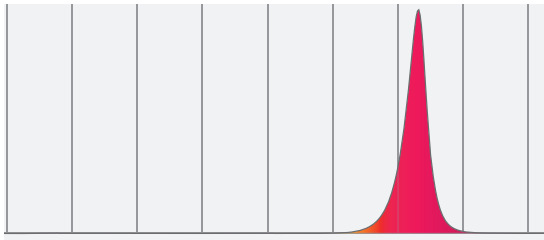

Dominant Wavelength	Color Coordinate CIE 1931	Color Coordinate CIE1931	Color Coordinate CIE 1964	Color Coordinate CIE 1964
nm	x	y	u	v
629	0.705	0.294	0.551	0.345

15 m
7 m

20 m
9.4 m

10 m
4.7 m

15 m
7 m

20 m
9.4 m

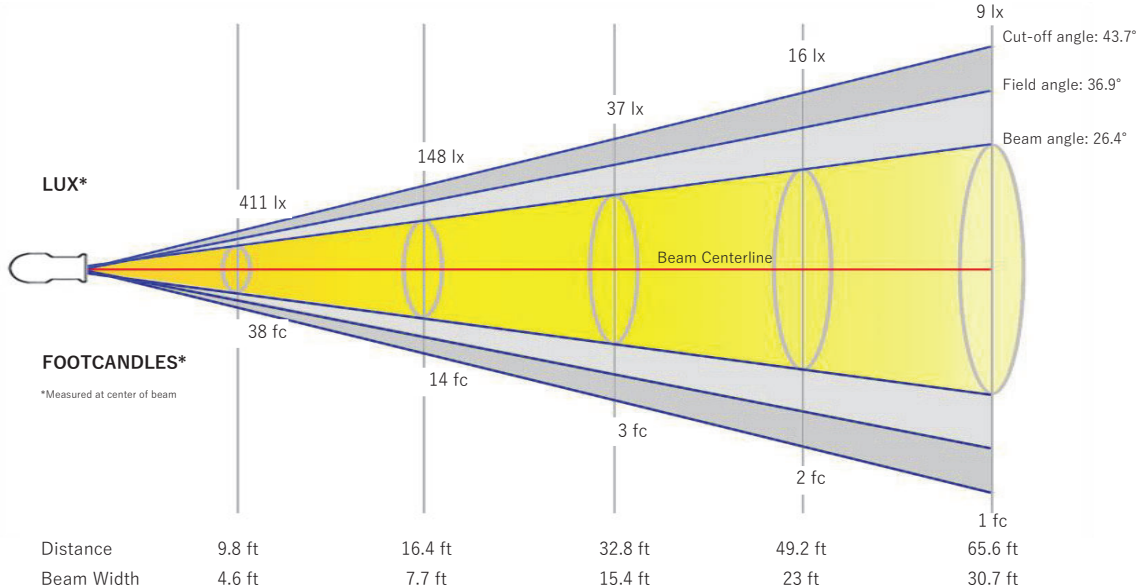

Beam Intensities from 1-20m

M	1	2	3	4	5	6	7	8	9	10	11	12	13	14	15	16	17	18	19	20
FT	3.3	6.6	9.8	13.1	16.4	19.7	23	26.2	29.5	32.8	36.1	39.4	42.7	45.9	49.2	52.5	55.8	59.1	62.3	65.6
LX	3695	924	411	231	148	103	75	58	46	37	31	26	22	19	16	14	13	11	10	9
FC	343.3	85.8	38.1	21.5	13.7	9.5	7	5.4	4.2	3.4	2.8	2.4	2	1.8	1.5	1.3	1.2	1.1	1	0.9

Measurements

Total Lumen Output: 1126 lm
 Peak Intensity: 5475 cd
 Efficacy: 34 Lumen/Watt
 Power: 33.5 W
 Voltage: 120 V, Current: 0.279 A

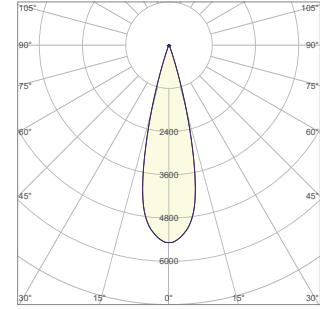

Spectral Power Distribution

Dominant Wavelength 527 nm

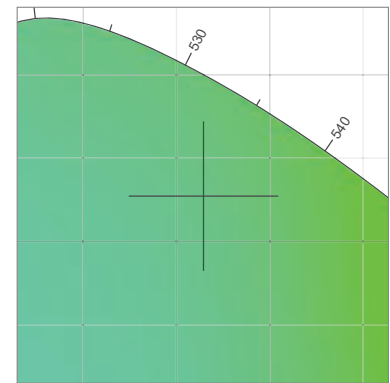
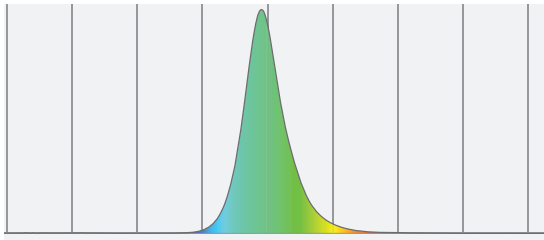

Dominant Wavelength	Color Coordinate CIE 1931	Color Coordinate CIE1931	Color Coordinate CIE 1964	Color Coordinate CIE 1964
nm	x	y	u	v
527	0.164	0.727	0.058	0.383

15 m
7 m

20 m
9.4 m

10 m
4.7 m

15 m
7 m

20 m
9.4 m

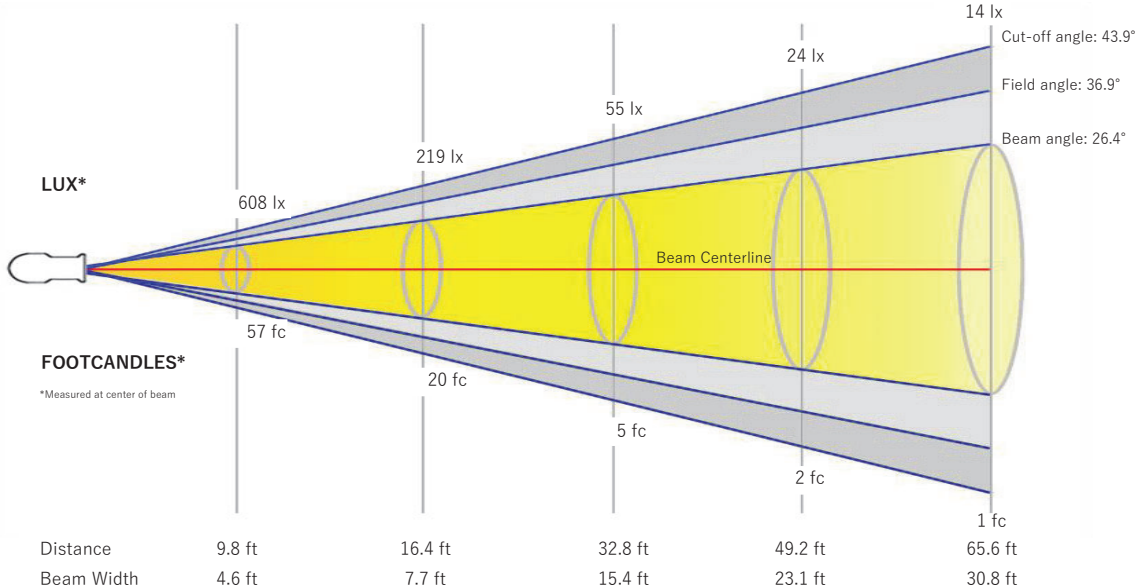

Beam Intensities from 1-20m

M	1	2	3	4	5	6	7	8	9	10	11	12	13	14	15	16	17	18	19	20
FT	3.3	6.6	9.8	13.1	16.4	19.7	23	26.2	29.5	32.8	36.1	39.4	42.7	45.9	49.2	52.5	55.8	59.1	62.3	65.6
LX	5475	1369	608	342	219	152	112	86	68	55	45	38	32	28	24	21	19	17	15	14
FC	508.6	127.2	56.5	31.8	20.3	14.1	10.4	7.9	6.3	5.1	4.2	3.5	3	2.6	2.3	2	1.8	1.6	1.4	1.3

Measurements

Total Lumen Output: 366 lm
 Peak Intensity: 1728 cd
 Efficacy: 6 Lumen/Watt
 Power: 65.4 W
 Voltage: 120 V, Current: 0.545 A

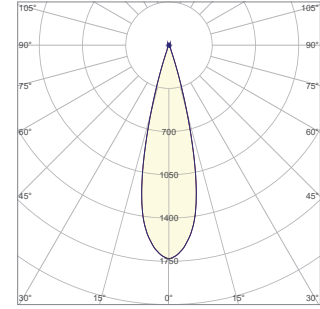

Spectral Power Distribution

Dominant Wavelength 455 nm

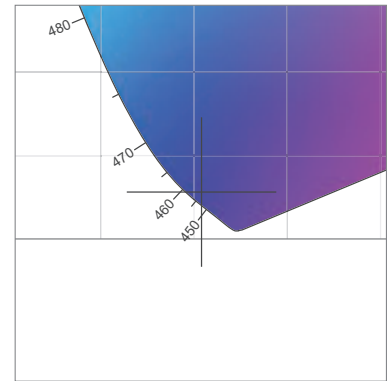
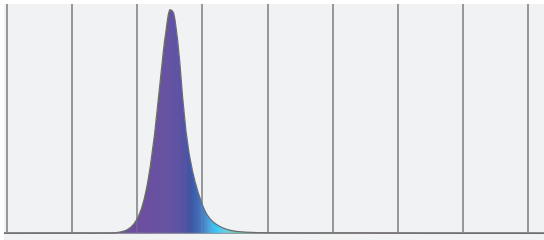

Dominant Wavelength	Color Coordinate CIE 1931	Color Coordinate CIE1931	Color Coordinate CIE 1964	Color Coordinate CIE 1964
nm	x	y	u	v
455	0.154	0.028	0.203	0.056

15 m
6.9 m

20 m
9.2 m

10 m
4.6 m

15 m
6.9 m

20 m
9.2 m

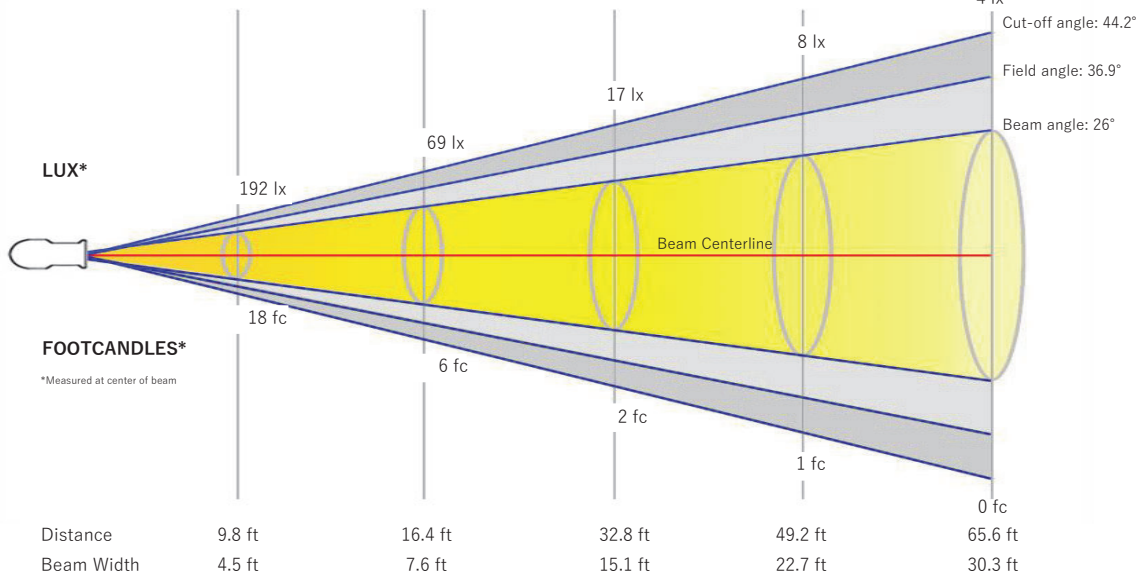

Beam Intensities from 1-20m

M	1	2	3	4	5	6	7	8	9	10	11	12	13	14	15	16	17	18	19	20
FT	3.3	6.6	9.8	13.1	16.4	19.7	23	26.2	29.5	32.8	36.1	39.4	42.7	45.9	49.2	52.5	55.8	59.1	62.3	65.6
LX	1728	432	192	108	69	48	35	27	21	17	14	12	10	9	8	7	6	5	5	4
FC	160.5	40.1	17.8	10	6.4	4.5	3.3	2.5	2	1.6	1.3	1.1	0.9	0.8	0.7	0.6	0.6	0.5	0.4	0.4

Measurements

Total Lumen Output: 3591 lm
 Peak Intensity: 18450 cd
 Efficacy: 44 Lumen/Watt
 Power: 81.0 W
 Voltage: 120 V, Current: 0.675 A

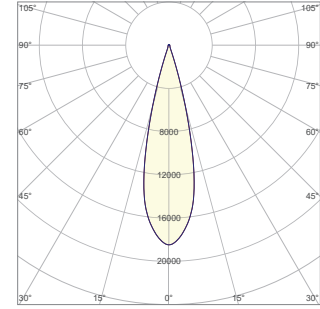

Spectral Power Distribution

Dominant Wavelength 561 nm

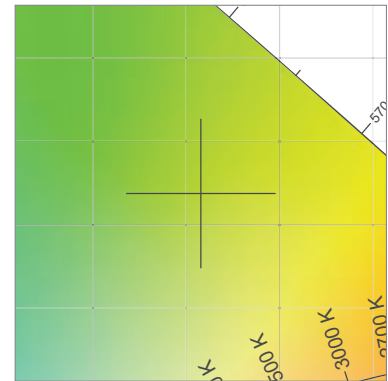
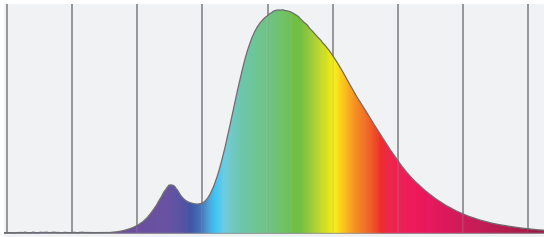

Dominant Wavelength	Color Coordinate CIE 1931	Color Coordinate CIE1931	Color Coordinate CIE 1964	Color Coordinate CIE 1964
nm	x	y	u	v
561	0.358	0.519	0.168	0.366

15 m
6.9 m

20 m
9.1 m

10 m
4.6 m

15 m
6.9 m

20 m
9.1 m

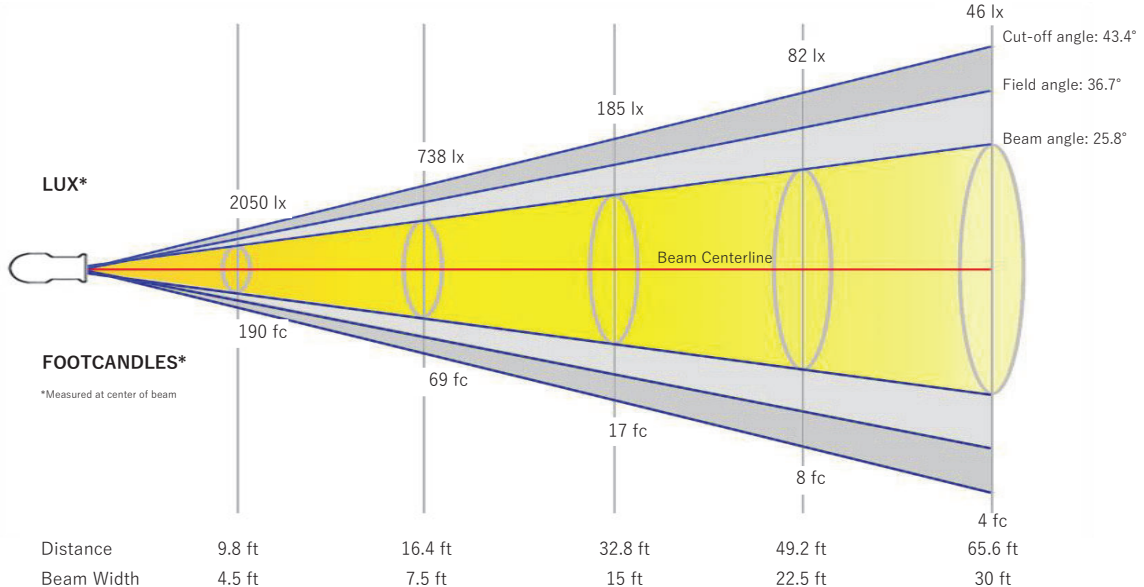

Beam Intensities from 1-20m

M	1	2	3	4	5	6	7	8	9	10	11	12	13	14	15	16	17	18	19	20
FT	3.3	6.6	9.8	13.1	16.4	19.7	23	26.2	29.5	32.8	36.1	39.4	42.7	45.9	49.2	52.5	55.8	59.1	62.3	65.6
LX	18450	4613	2050	1153	738	513	377	288	228	185	152	128	109	94	82	72	64	57	51	46
FC	1714.1	428.5	190.5	107.1	68.6	47.6	35	26.8	21.2	17.1	14.2	11.9	10.1	8.7	7.6	6.7	5.9	5.3	4.7	4.3

Measurements

Total Lumen Output: 1136 lm
 Peak Intensity: 5470 cd
 Efficacy: 18 Lumen/Watt
 Power: 63.7 W
 Voltage: 120 V, Current: 0.531 A

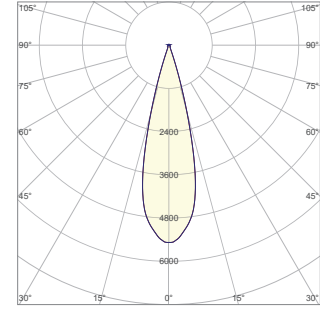

Spectral Power Distribution

Dominant Wavelength 591 nm

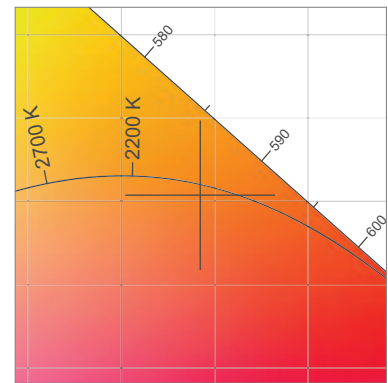
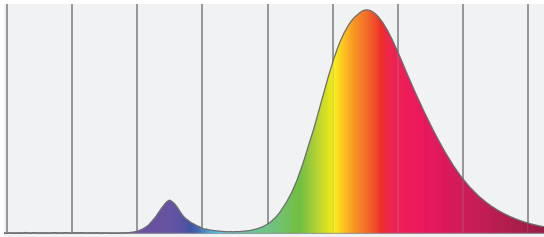

Dominant Wavelength	Color Coordinate CIE 1931	Color Coordinate CIE1931	Color Coordinate CIE 1964	Color Coordinate CIE 1964
nm	x	y	u	v
591	0.542	0.404	0.321	0.358

15 m
7.1 m

20 m
9.5 m

10 m
4.8 m

15 m
7.1 m

20 m
9.5 m

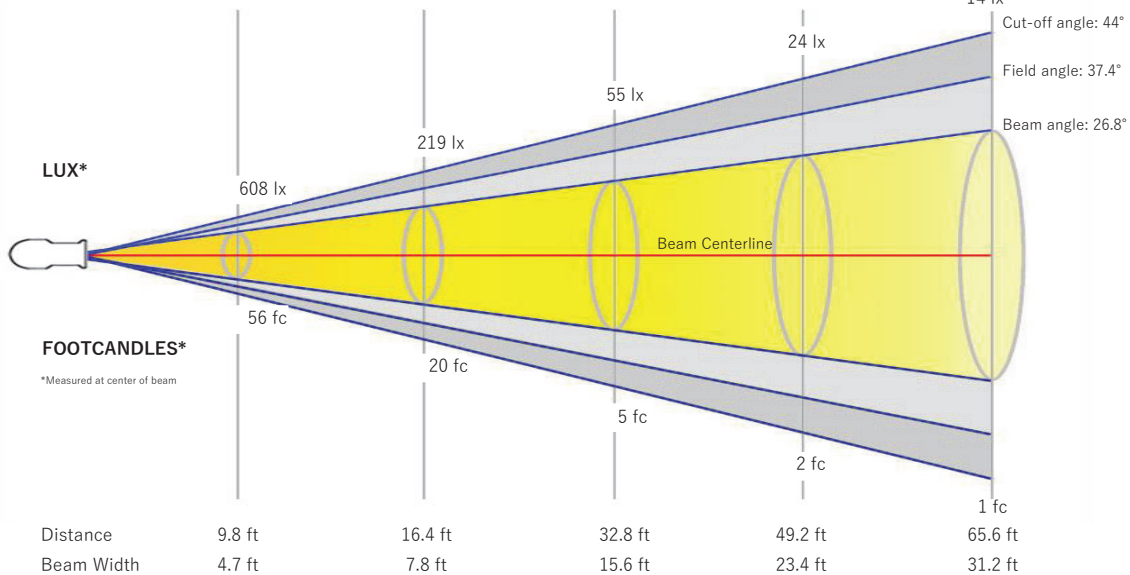

Beam Intensities from 1-20m

M	1	2	3	4	5	6	7	8	9	10	11	12	13	14	15	16	17	18	19	20
FT	3.3	6.6	9.8	13.1	16.4	19.7	23	26.2	29.5	32.8	36.1	39.4	42.7	45.9	49.2	52.5	55.8	59.1	62.3	65.6
LX	5470	1368	608	342	219	152	112	85	68	55	45	38	32	28	24	21	19	17	15	14
FC	508.2	127.1	56.5	31.8	20.3	14.1	10.4	7.9	6.3	5.1	4.2	3.5	3	2.6	2.3	2	1.8	1.6	1.4	1.3