



# PAR IP COMPACT OPS



150W RGBMA LED PAR, Outdoor Permanent Spec

DATA SHEET



## KEY FEATURES

150W RGBMA LED Engine

5,474 Total Fixture Lumen Output (Sphere)

Field Replaceable Lenses

RDM (Remote Device Management)

NFC & Aria x2 Wireless Device Management

6.25" Gel Frame and Four Lenses (11°, 22°, 30°, 52°) Included

Hard Wired (Bare Wire) IP Rated Power and Data Cables Attached

Special Marine Grade Exterior Coating

The **KL PAR IP COMPACT OPS** includes the same features as the standard KL PAR IP Compact model but adds a CX Marine Grade exterior coating and Hard Wired (bare wire) IP-rated power and data cables and is designed for permanent marine/coastal environment installations.

Compact, powerful, and versatile, the **KL PAR IP COMPACT OPS** delivers exceptional lighting performance in a small, rugged package. This IP65-rated LED fixture offers precise color temperature control, full-spectrum rendering, and consistent wash coverage, powered by a highly efficient RGBMA engine that provides up to 5,474 lumens. Its advanced control software delivers exceptional color accuracy (CRI 94.9, TLCI 95), 16-bit variable CCT control, and adjustable LED refresh frequency.

The **KL PAR IP COMPACT OPS** comes with several features optimized for integration. Dim-to-warm and redshift emulate a classic incandescent glow, while CMY emulation, green/magenta shift, and a virtual gel library facilitate access to vibrant LED colors and pre-mixed shades. Color shift correction and matching the camera's white balance are possible without additional gels or filters. The fixture's LED refresh rate can be remotely adjusted, ensuring flicker-free performance with high-speed cameras.

The **KL PAR IP COMPACT OPS** can be operated through industry-standard DMX protocols and has full RDM support. The on-board display and control buttons have been removed to prevent unwanted access or accidental button presses in permanent installations. Aria x2 wireless device management integration and NFC configuration provide convenient remote setup and configuration without the need for physical interaction with the fixture.

The IP65 housing can be ordered in BLACK or WHITE color. The 6.25" gel frame and multiple included field-replaceable lenses (11°, 22°, 30°, 52°) allow it to adapt seamlessly to diverse production requirements. Optional 6.25" barndoors further enhance its capabilities. Hard wired (bare wire) IP-rated power and data cables and stainless-steel fasteners ensure long-term reliability in demanding permanent outdoor and marine environments.

The **KL PAR IP COMPACT OPS** is an ideal fixture for Themed Environments, Hospitality, or Installations where high output, broadcast-grade color quality, compact form factor, and permanent installation are required.



**SOURCE**

150W 6000K RGBMA LED Engine  
30,000 Hour Average LED Life\*

\*Test lab conditions. May vary depending on several factors including but not limited to: Environmental Conditions, Power/Voltage, Usage Patterns (On-Off Cycling), Control, and Dimming.

**PHOTOMETRIC DATA**

Total Lumen Output:  
5,474 (Integrating Sphere)  
4,722 (Goniometer)  
CRI 94.9  
TLCI 95

**INCLUDED LENSES**

VNSP-11  
NSP-22  
MFL-30  
WFL-52

**EFFECTS**

Variable Strobe Rate: 1- 20Hz  
Dim-to-Warm/ Red Shift Emulation  
Variable 16-bit Dimming Modes and Curves

**COLOR**

RGBMA Color Array  
CMY Emulation  
16bit Fully Variable CCT 2400K - 8500K  
Green/Magenta Shift  
Virtual Gel Swatch Book

**CONTROL / CONNECTIONS**

8 DMX Channel Modes (1, 4, 6, 10, 11, 19, 9, 15)  
RDM (Remote Device Management)  
Aria x2 Wireless Device Management  
NFC Configuration  
Hard Wired (Bare Wire) IP Rated Power and  
Data Cables, 3 meters with the following cable  
options:  
2-Wire- Power In & Combination DMX In/Out  
Cables  
4-Wire- Power In, Power Out, DMX In and DMX  
Out Cables

**SIZE / WEIGHT**

Length: 7.2" (183mm)  
Length (Yoke 90°): 11.1" (283mm)  
Width: 9.8" (249mm)  
Height (Fixture Body): 10.8" (275mm)  
Height (Yoke 0°): 13.1" (332mm)  
Weight: 35.5 lbs (16.1kg)

**ELECTRICAL / THERMAL**

AC 100-240V - 50/60Hz  
200W Max Power Consumption  
Power Thru Capacity: 10A (6 units @115V, 12  
units @240V)  
5°F to 113°F (-15°C to 45°C)  
BTU/hr (+/- 10%) 682

**INCLUDED ITEMS**

Gel Frame  
Safety Cable  
4 Lenses (NSP-22, VNSP-11, MFL-30, and WFL-  
52)

**OPTIONAL ITEMS**

6.25" Barndoors  
Omega Bracket  
4 Wire OPS Hardwire Installation Plate  
(HWP414)  
2 Wire OPS Hardwire Installation Plate  
(HWP212)

**APPROVALS / RATINGS**

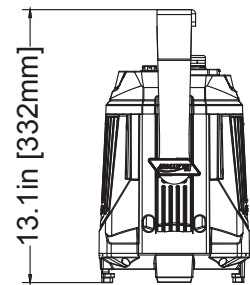
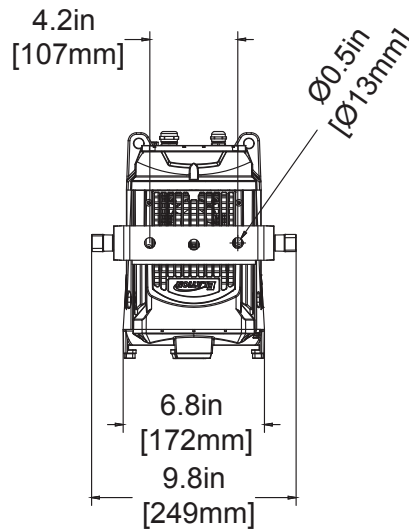
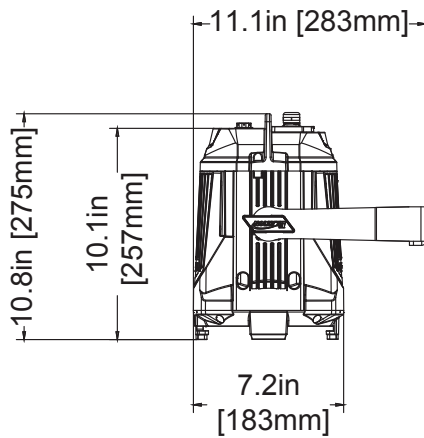
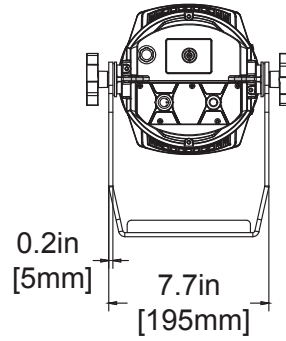
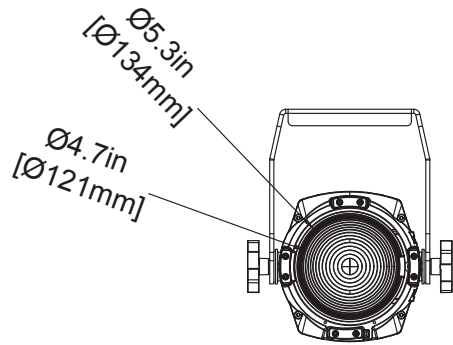

## ORDERING INFORMATION

KL0812	1236100197	KL Par IP Compact OPS
PENDING	PENDING	6.25" Barndoor

