

# **ELATION®**

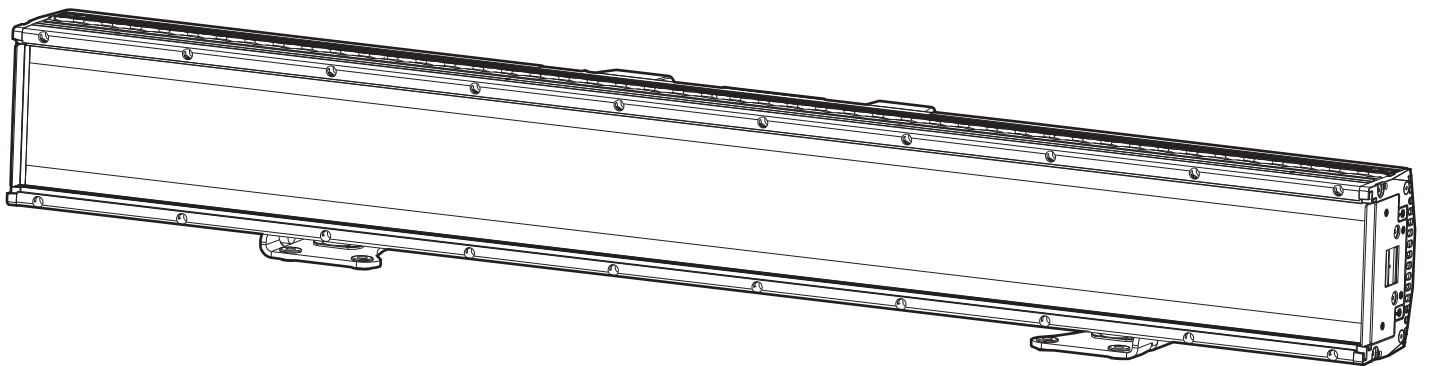

**Batten 48**

user manual

©2026 ELATION PROFESSIONAL all rights reserved. Information, specifications, diagrams, images, and instructions herein are subject to change without notice. ELATION PROFESSIONAL logo and identifying product names and numbers herein are trademarks of ELATION PROFESSIONAL. Copyright protection claimed includes all forms and matters of copyrightable materials and information now allowed by statutory or judicial law or hereinafter granted. Product names used in this document may be trademarks or registered trademarks of their respective companies and are hereby acknowledged. All non-ELATION brands and product names are trademarks or registered trademarks of their respective companies.

**ELATION PROFESSIONAL** and all affiliated companies hereby disclaim any and all liabilities for property, equipment, building, and electrical damages, injuries to any persons, and direct or indirect economic loss associated with the use or reliance of any information contained within this document, and/or as a result of the improper, unsafe, insufficient and negligent assembly, installation, rigging, and operation of this product.

**Elation Professional USA | 6122 S. Eastern Ave. | Los Angeles, CA. 90040**

323-582-3322 | [www.elationlighting.com](http://www.elationlighting.com) | [info@elationlighting.com](mailto:info@elationlighting.com)

**Elation Professional B.V. | Junostraat 2 | 6468 EW Kerkrade, The Netherlands**

+31 45 546 85 66 | [www.elationlighting.eu](http://www.elationlighting.eu) | [info@elationlighting.eu](mailto:info@elationlighting.eu)

**Elation Professional Mexico | AV Santa Ana 30 | Parque Industrial Lerma, Lerma, Mexico 52000**

+52 (728) 282-7070

## DOCUMENT VERSION



Due to additional product features and/or enhancements, an updated version of this document may be available online. Please scan the QR Code with your mobile device or visit [www.elationlighting.com](http://www.elationlighting.com) for the latest revision/update of this manual, before installation and/or programming.

Date	Document Version	Software Version	DMX Channels	Notes
03/20/2026	1.0	1.01	1 / 3A / 4A / 4B / 3B / 6A / 10 / 14 / 22 / 16A / 6B / 8 / 6C / 20A / 20B / 35 / 12A / 16B / 12B / 40 / 32A / 61 / 24A / 32B / 24B / 80 / 56 / 113 / 48A / 64 / 48B / 160 / 104 / 217 Ch	Initial Release
04/16/2026	1.1	N/C	No Change	Updated: DMX Traits, Dimensional Drawings, Specifications
05/13/2026	1.2	N/C	No Change	Updated: General Info, Fan Modes, DMX Traits

# CONTENTS

<b>General Information</b>	<b>4</b>
<b>IP65 Rated</b>	<b>5</b>
<b>Safety Guidelines</b>	<b>6</b>
<b>Overview</b>	<b>8</b>
<b>Installation Guidelines</b>	<b>9</b>
<b>Accessory Installation</b>	<b>15</b>
<b>Near Field Communication (NFC)</b>	<b>17</b>
<b>Aria Setup and Guidelines</b>	<b>18</b>
<b>Remote Device Management (RDM)</b>	<b>21</b>
<b>Control Panel</b>	<b>22</b>
<b>System Menu</b>	<b>23</b>
<b>Fan Modes</b>	<b>27</b>
<b>DMX Traits</b>	<b>28</b>
<b>DMX Traits - Single Cell</b>	<b>29</b>
<b>DMX Traits - 2 cell</b>	<b>36</b>
<b>DMX Traits - 4 cell</b>	<b>43</b>
<b>DMX Traits - 8 cell</b>	<b>52</b>
<b>DMX Traits - 16 cell</b>	<b>65</b>
<b>Cell Zones</b>	<b>86</b>
<b>Color Temperature Table</b>	<b>88</b>
<b>Virtual Colors</b>	<b>89</b>
<b>Effect Selection</b>	<b>90</b>
<b>Dimmer Curves</b>	<b>91</b>
<b>Maintenance Guidelines   Error Codes</b>	<b>92</b>
<b>Torque Settings for Screws</b>	<b>93</b>
<b>IP Test Parameters</b>	<b>94</b>
<b>Software Updates   Ordering Information</b>	<b>95</b>
<b>Specifications</b>	<b>96</b>
<b>Dimensional Drawings</b>	<b>97</b>
<b>FCC Statement</b>	<b>98</b>

# GENERAL INFORMATION

## INTRODUCTION

Please read and understand the instructions in this manual carefully and thoroughly before attempting to operate this device. These instructions contain important safety and use information. **This device is intended for professional use only.**

## UNPACKING

Every device has been thoroughly tested and has been shipped in perfect operating condition. Carefully check the shipping carton for damage that may have occurred during shipping. If the carton is damaged, carefully inspect the device for damage, and be sure all accessories necessary to install and operate the device have arrived intact. In the event damage has been found or parts are missing, please contact our customer support team for further instructions. Please do not return this device to your dealer without first contacting customer support. Please do not discard the shipping carton in the trash. Please recycle whenever possible.

## BOX CONTENTS

Safety Cable (x1)  
Border Light Filter (x1)  
Glare Shield (x1)  
Power Cable (x2)

## CUSTOMER SUPPORT

Contact ELATION Service for any product related service and support needs. Also visit [forums.elationlighting.com](https://forums.elationlighting.com) with questions, comments or suggestions.

**ELATION SERVICE USA - Monday - Friday 8:00am to 4:30pm PST**  
**323-582-3322 | [support@elationlighting.com](mailto:support@elationlighting.com)**

**ELATION SERVICE EUROPE - Monday - Friday 08:30 to 17:00 CET**  
**+31 45 546 85 63 | [support@elationlighting.eu](mailto:support@elationlighting.eu)**

**REPLACEMENT PARTS** please visit [parts.elationlighting.com](https://parts.elationlighting.com)

## LIMITED WARRANTY

For up-to-date warranty information regarding your device, please visit Elation's warranty information page online or scan the QR codes below.



**USA: <https://www.elationlighting.com/warranty-information>**

**EU: [https://www.elationlighting.eu/terms\\_and\\_conditions](https://www.elationlighting.eu/terms_and_conditions)**

**THERE ARE NO USER SERVICEABLE PARTS INSIDE THIS UNIT. DO NOT ATTEMPT ANY REPAIRS YOURSELF, AS DOING SO WILL VOID YOUR MANUFACTURER'S WARRANTY. DAMAGES RESULTING FROM MODIFICATIONS TO THIS FIXTURE AND/OR THE DISREGARD OF SAFETY INSTRUCTIONS AND GUIDELINES IN THIS MANUAL VOID THE MANUFACTURER'S WARRANTY AND ARE NOT SUBJECT TO ANY WARRANTY CLAIMS AND/OR REPAIRS.**

# IP65 RATED

The **International Protection (IP)** rating system is commonly expressed as “**IP**” (Ingress Protection) followed by two numbers (i.e. IP65), where the numbers define the degree of protection. The first digit (Foreign Bodies Protection) indicates the extent of protection against particles entering the fixture, and the second digit (Water Protection) indicates the extent of protection against water entering the fixture. An **IP65** rated lighting fixture is designed and tested to protect against the ingress of dust (**6**), and low-pressure water jets from any direction (**5**).

**NOTE: THIS FIXTURE IS INTENDED FOR TEMPORARY OUTDOOR USE ONLY!**

**Maritime/Seaside Environment Installations:** A maritime/seaside environment is adjacent to the sea and caustic to electronics through exposure to atomized salt water and humidity, whereas a coastal environment extends 5 miles inland.



**NOT suitable for maritime/seaside environment installations. Installing this fixture in a maritime/seaside environment may cause corrosion and/or excessive wear to the interior and/or exterior components of the fixture. Damages and/or performance issues resulting from installation in a maritime/seaside environment will void the manufacturer’s warranty, and will NOT be subject to any warranty claims and/or repairs.**

Maritime installations require additional preparation, and additional service intervals may be needed given the maritime use. In general, IP ratings presuppose freshwater conditions VS maritime conditions, which are typically more “caustic” to IP fixtures (both internally and externally). A duty-cycle may also be needed when units are not in use. During times of high humidity and colder temperatures, condensation may occur internally so the fixture may require a duty-cycle to bring it up to running temperature, allowing any accumulation of moisture to be expelled via the vent valve. Recommendations can change based on installation environmental circumstances. A waterproof dome or similar device is recommended for use in permanent outdoor installations. When using a dome, refer to manufacturer recommendations for duty-cycle.

**NOTE: NOT ALL FEATURES LISTED ARE AVAILABLE ON ALL FIXTURES; THE FOLLOWING INSTRUCTIONS MAY NOT APPLY. CONTACT SUPPORT FOR ADDITIONAL DETAILS.**

**Exterior Maintenance:** Inspect the exterior every 30-days. The unit must be powered off/disconnected. The chassis should be inspected for any signs of contaminants. Inspect optics to determine if the lens is obstructed, then clean optics and chassis accordingly. Based on initial finding, schedule maintenance accordingly, keeping in mind that exterior maintenance will be required. Even if the luminaires are NOT in use, maintenance will still be needed given its location (exterior use). The use of a durable type of wax on the chassis is recommended since it will help prevent contaminant build up. Inspect both power and data lines for any signs of contaminants or corrosion. Periodically reapplying di-electric grease, especially in coastal environments. If any signs of corrosion/contaminants are present, clean thoroughly, and/or replace connectors, then reapply di-electric grease. Typically, this should be done annually, or any time an opportunity presents itself. As a preventive measure, annual replacement of both vent valves is recommended. The vent valve membrane can become contaminated and/or clogged causing improper venting of humidity within the luminaire. Inspect all mounting hardware as a precaution.

**Interior Maintenance:** Inspect the interior every 30-days. The unit must be powered off/disconnected.

- Inspect zoom/focus mechanism, clean optics, lubricate linear bearings (Krytox oil) as needed, inspect belts for wear
- Inspect all rotating effect wheels, manually rotate them, note any resistance
- Inspect all remaining rotating belts for any wear
- Inspect all fans, clean as needed, check rotation, check connections
- Inspect CMY module, manually move flags and check for signs of resistance, and if needed, clean guide rods first, then reapply a thin layer of grease (moly lube)
- Clean interior with low-volume compressed air, then clean optics prior to reassembly of head covers

Although the base has limited moving parts, the pan belt should also be inspected for wear. Remember to always perform an IP test anytime a cover is removed.

There is no specific time frame regarding the routine replacement of parts such as belts/stepper motors, PCBs, or LEDs. These items should only be replaced on an as needed bases, except for cooling fans, which should be replaced once the luminaries reach 10,000-hours. This is a prophylactic measure intended to keep the unit running as cool as possible, insuring proper function of all internal components. A complete service breakdown is available, please contact [service@elationlighting.com](mailto:service@elationlighting.com) for any needed parts or manuals.

# SAFETY GUIDELINES

This fixture is a sophisticated piece of electronic equipment. To guarantee a smooth operation, it is important to follow all instructions and guidelines in this manual. Elation Professional is not responsible for injury and/or damages resulting from the misuse of this fixture due to the disregard of the information printed in this manual. Only qualified and/or certified personnel should perform installation of this fixture and only the original rigging parts (such as omega brackets) included with this fixture should be used for installation. Any modifications to the fixture and/or the included mounting hardware will void the original manufacturer's warranty and increase the risk of damage and/or personal injury.



**PROTECTION CLASS 1 - FIXTURE MUST BE PROPERLY GROUNDED.**



**THERE ARE NO USER SERVICEABLE PARTS INSIDE THIS UNIT. DO NOT ATTEMPT ANY REPAIRS YOURSELF; DOING SO WILL VOID YOUR MANUFACTURER'S WARRANTY. DAMAGES RESULTING FROM MODIFICATIONS TO THIS FIXTURE AND/OR THE DISREGARD OF SAFETY INSTRUCTIONS AND GUIDELINES IN THIS MANUAL VOID THE MANUFACTURER'S WARRANTY AND ARE NOT SUBJECT TO ANY WARRANTY CLAIMS AND/OR REPAIRS.**



**DO NOT PLUG FIXTURE INTO A DIMMER PACK!  
NEVER OPEN THIS FIXTURE WHILE IN USE!  
UNPLUG POWER BEFORE SERVICING FIXTURE!  
NEVER TOUCH FIXTURE DURING OPERATION, AS IT MAY BE HOT!  
KEEP FLAMMABLE MATERIALS AWAY FROM FIXTURE!**



**NEVER LOOK DIRECTLY INTO THE LIGHT SOURCE!  
RETINA INJURY RISK - MAY INDUCE BLINDNESS!  
SENSITIVE PERSONS MAY SUFFER AN EPILEPTIC SHOCK!**



**MINIMUM DISTANCE TO OBJECTS/SURFACES MUST BE 1.6 FEET (0.5 METERS)  
MINIMUM DISTANCE OF FLAMMABLE MATERIALS FROM THE SURFACE 1.6 FEET (0.5 METER)  
MINIMUM DISTANCE TO LIGHTED OBJECTS IS 1.6 FEET (0.5 METERS)  
AMBIENT OPERATING TEMPERATURE RANGE IS -40°F TO 131°F (-40°C TO 55°C)**

# SAFETY GUIDELINES

- **DO NOT** shake fixture, and avoid using brute force when installing and/or operating the fixture.
- **DO NOT** operate the fixture if the power cord is frayed, crimped, damaged, and/or if any of the power cord connectors are damaged and do not plug into the fixture securely with ease.
- **NEVER** force a power cord connector into the fixture. If the power cord or any of its connectors are damaged, replace it immediately with a new one of the same power rating.
- **DO NOT** block any air ventilation slots.
- All fan and air inlets must remain clean and never blocked.
- Leave approx. 6" (15cm) between the fixture and other devices or a wall in order to allow for proper cooling.
- Always disconnect the fixture from the main power source before performing any type of service and/or cleaning procedure.
- Only handle the power cord by the plug end. Never pull out the plug by tugging on the wire portion of the cord.
- Consistent operational breaks will ensure fixture will function properly for many years.
- **ONLY** use the original packaging and materials to transport the fixture for service.
- This fixture is intended for professional use only.
- The light source contained in this fixture shall only be replaced by the manufacturer or manufacturer's service agent or similar qualified person.

# OVERVIEW

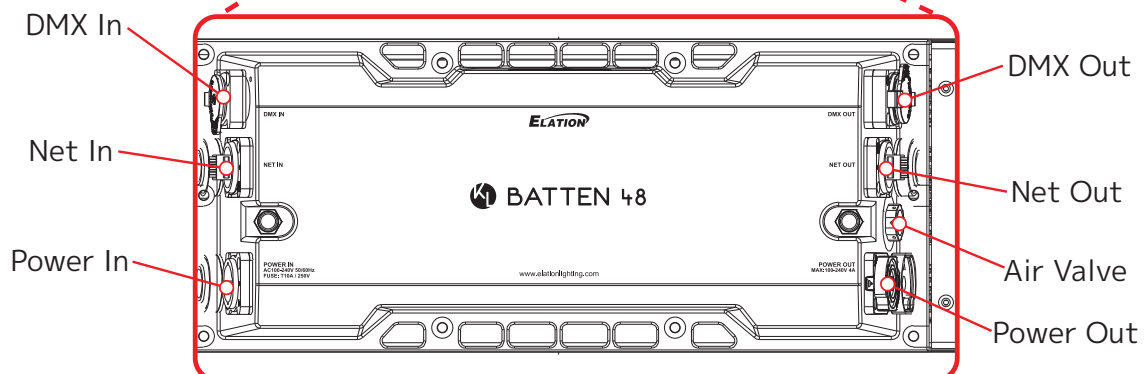
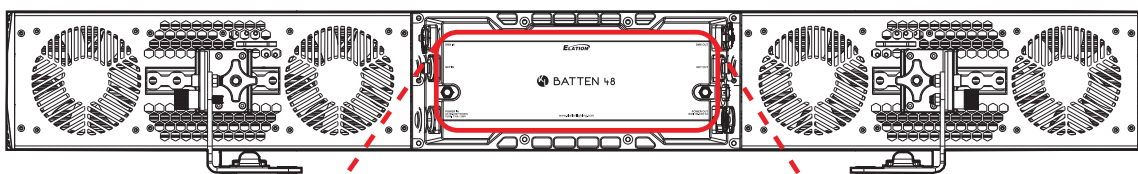
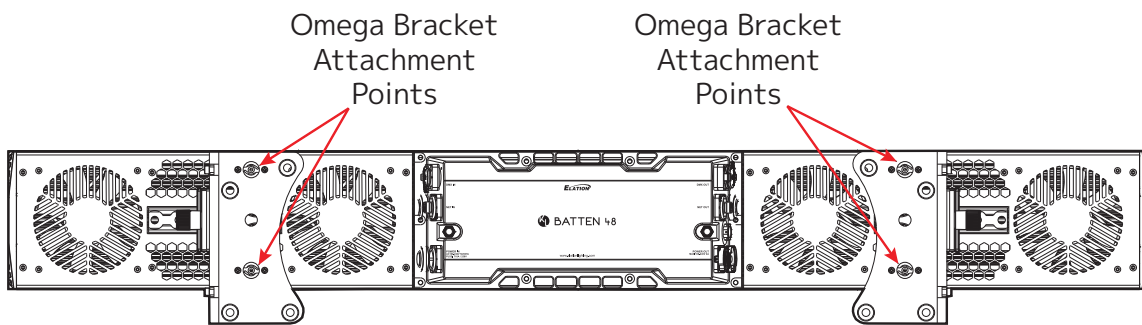
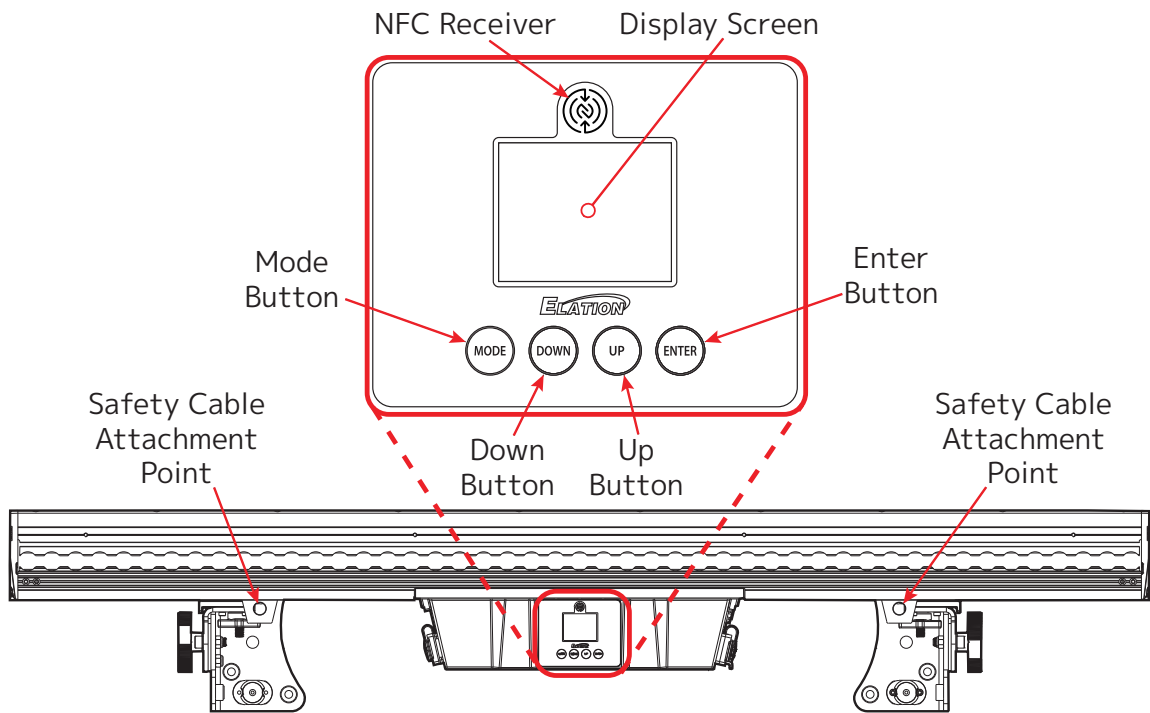

# INSTALLATION GUIDELINES



## **FLAMMABLE MATERIAL WARNING**

Keep fixture minimum 1.6 feet (0.5m) away from flammable materials and/or pyrotechnics.



## **ELECTRICAL CONNECTIONS**

A qualified electrician should be used for all electrical connections and/or installations.



**MINIMUM DISTANCE TO SURFACES/OBJECTS IS 1.6 FEET (0.5 METER).**

**MINIMUM DISTANCE TO FLAMMABLE MATERIALS IS 1.6 FEET (0.5 METER).**

**MINIMUM DISTANCE TO LIGHTED OBJECTS IS 1.6 FEET (0.5 METERS)**

**AMBIENT OPERATING TEMPERATURE RANGE IS -40°F TO 131° F (-40°C TO 55° C).**



**DO NOT INSTALL THE FIXTURE IF YOU ARE NOT QUALIFIED TO DO SO!**

Fixture **MUST** be installed following all local, national, and country commercial electrical and construction codes and regulations.

Before rigging/mounting the fixture to any metal truss/structure or placing the fixture on any surface, a professional equipment installer **MUST** be consulted to determine if the metal truss/structure or surface is properly certified to safely hold the combined weight of the fixture, clamps, cables, and accessories.

Overhead rigging requires extensive experience, including, amongst others, calculating working load limits, installation material being used, and periodic safety inspection of all installation material and the fixture. If you lack these qualifications, do not attempt the installation yourself. Improper installation can result in bodily injury.

Ambient operating temperature range is **-40°F to 131°F (-40°C to 55°C)**. Do not operate the fixture when the ambient temperature falls outside this range.

Fixture(s) should be installed away from walking paths, seating areas, or areas where unauthorized personnel might reach the fixture by hand.

**NEVER** stand directly below the fixture(s) when rigging, removing, or servicing.

Overhead fixture installation must always be secured with a secondary safety attachment, such as an appropriately rated safety cable.

Allow approximately 15 minutes for the fixture to cool down before servicing.

Powering down the fixture when not in use is strongly recommended.

## **CONDENSATION AND MOISTURE INSPECTION**

Before powering on, remove the fixture from its packaging or road case in a dry, controlled environment and inspect for transport damage or signs of condensation/moisture caused by temperature changes (e.g., cold storage to warm venue). Allow full acclimation to ambient temperature (at least 1–2 hours) until any condensation evaporates completely to prevent electrical damage, short circuits, or corrosion. Do not operate if moisture is present, as this may cause irreversible damage and void the warranty. If issues persist, consult the troubleshooting guide or contact technical support.

# INSTALLATION GUIDELINES

## ADJUSTABLE BRACKET POSITION FOR LOW CLEARANCES:

The position of the mount brackets can be adjusted to allow for low clearance configurations. In order to do this, simply remove the two nuts on the inside of the bracket arm, then slide the bracket arm off of the angle adjustment mechanism.

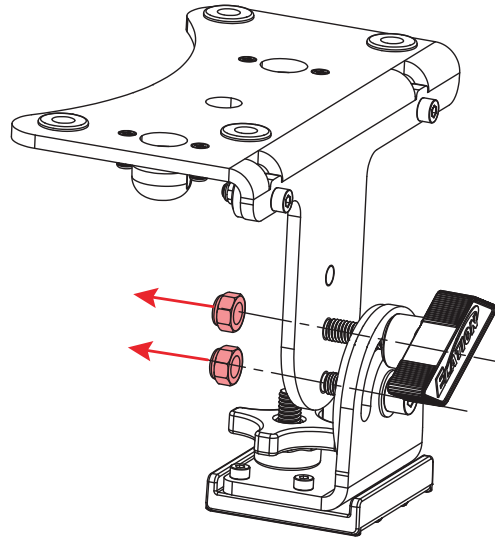

For the high clearance position, insert the bolts on the angle adjustment mechanism into the bottom and middle holes on the bracket arm, as shown on the left. For the low clearance position, insert the bolts on the angle adjustment mechanism into the middle and top holes on the bracket arm, as shown on the right. Re-attach the nuts to secure in place.

### HIGH CLEARANCE

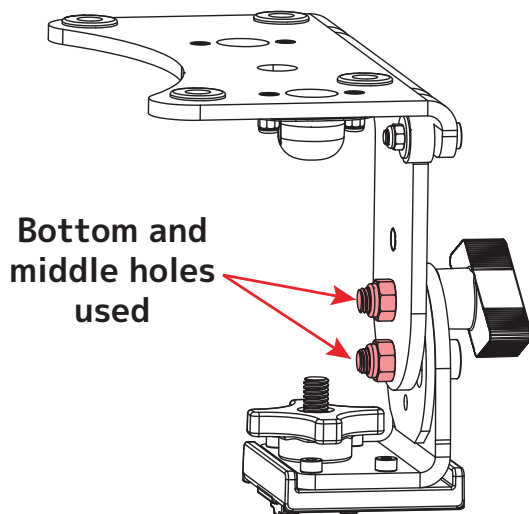

### LOW CLEARANCE

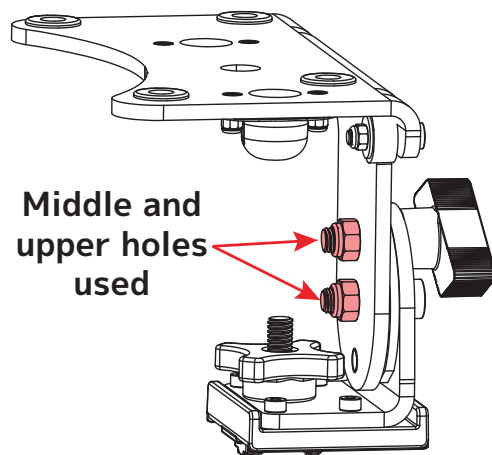

# INSTALLATION GUIDELINES

## OMEGA BRACKETS WITH CLAMP INSTALLATION:

When mounting a fixture to a truss, be sure to secure an appropriately rated professional grade rigging clamp to each included **Omega bracket** using an M10 screw fitted through the center hole of the Omega bracket. Insert the Omega bracket into the mounting holes on the fixture yoke. Secure the Omega brackets to the fixture by turning each quick-lock fastener 1/4 turn clockwise, making sure the fastener is completely locked. **Please note that two Omega brackets and two mounting clamps are required to securely install this fixture.** Omega brackets can be installed onto the fixture as illustrated below.

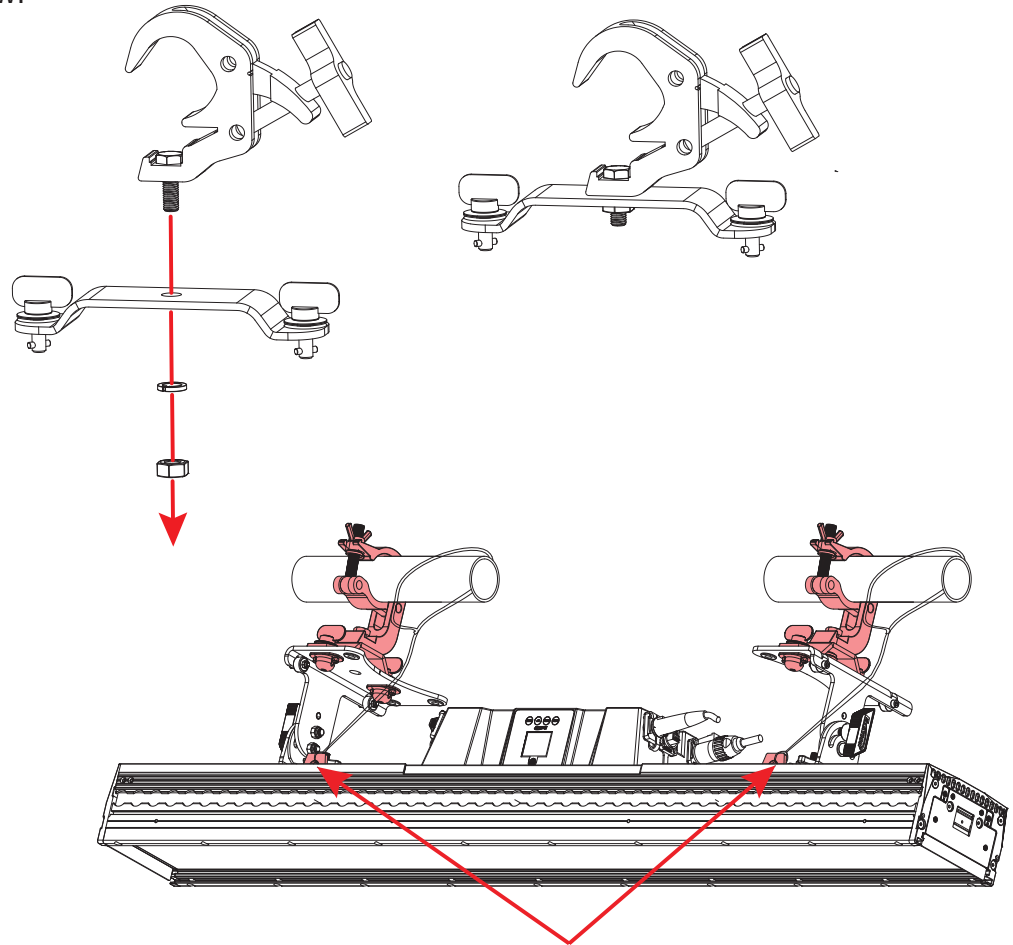

**ALWAYS ATTACH SAFETY CABLES WHENEVER INSTALLING THIS FIXTURE IN A SUSPENDED ENVIRONMENT TO ENSURE THAT THE FIXTURE WILL NOT FALL IF THE CLAMP FAILS.**

**Safety Cable Attachment Points**

## RIGGING

Overhead rigging requires extensive experience, including but not limited to: calculating working load limits, knowledge of installation material being used, and periodic safety inspection of all installation material and the fixture. If you lack these qualifications, do not attempt to perform the installation yourself, as improper installation can result in bodily injury. The fixture provides built in rigging points for a **SAFETY CABLES** (not included) near the base of each mounting yoke. Be sure to use only the designated rigging points for the safety cable, and **NEVER** use any other point to secure the safety cable. Connect the safety cable to the attachment point and route it around the truss.

# INSTALLATION GUIDELINES

## ASYMMETRICAL LENS ORIENTATION

This fixture features a special compound lens which is designed to create even illumination on vertical surfaces such as walls or cycloramas. The section of the lens that features linear refraction patterns should be oriented nearest to the vertical surface that is being illuminated, while the section without these patterns should be oriented further away. The fixture's silk screen clearly indicates the side of the fixture that should be oriented towards the vertical surface. Please refer to the images below.

**Un-patterned section  
should be oriented away from  
the wall or vertical surface**



**Linear Refraction Patterns  
should be oriented toward  
the wall or vertical surface**

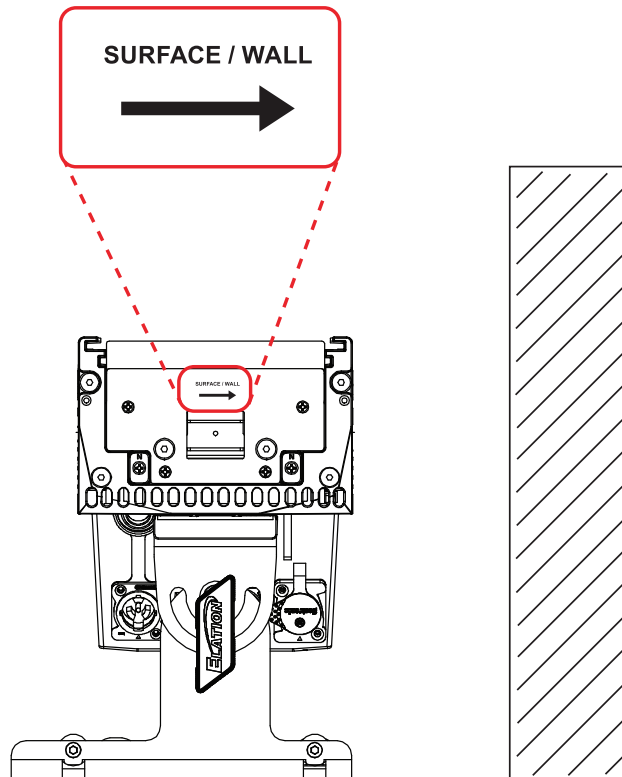

# INSTALLATION GUIDELINES

## POTENTIAL INTERNAL FIXTURE DAMAGE FROM EXTERNAL SOURCES OF LIGHT BEAMS

External sources of light beams from direct sunlight, lighting and moving head fixtures, and lasers, which are focused directly towards the exterior housing and/or penetrate the front lens opening of Elation lighting fixtures, can cause severe internal damage including burning of optics, dichroic color filters, glass and metal gobos, prisms, animation wheels, frost filters, iris, shutters, motors, belts, wiring, discharge lamps, and LEDs.

This issue is not specific only to Elation lighting fixtures, but rather it is a common issue with lighting fixtures from all manufacturers. Although there is no true way to fully prevent this issue from happening, the guidelines below can reduce the risk of potential damage. Contact Elation Service for more details.

**DO NOT EXPOSE THE FIXTURE AND/OR FRONT LENS OPENING TO LIGHT BEAMS FROM DIRECT SUNLIGHT, OTHER FIXTURES, OR LASERS UNDER ANY CIRCUMSTANCES. PLEASE NOTE THAT THIS INCLUDES EXTENDED PERIODS OF NON-USE, AS DAMAGE CAN OCCUR EVEN WHEN THE FIXTURE IS OFF. NEVER FOCUS A LIGHT BEAM FROM ONE LIGHTING FIXTURE DIRECTLY TOWARDS ANOTHER.**

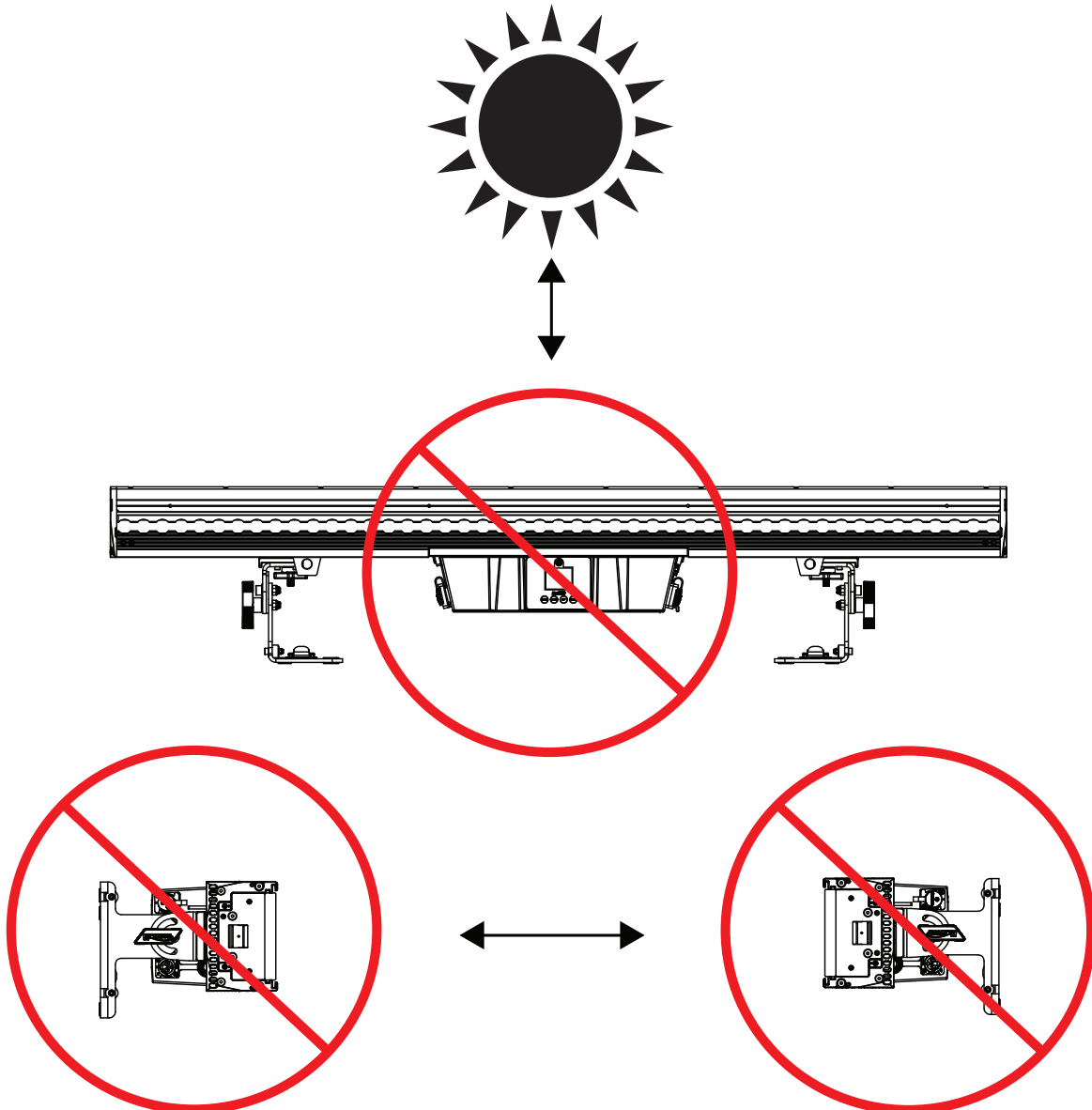

# INSTALLATION GUIDELINES

## RIGGING

Overhead rigging requires extensive experience, including calculating working load limits, installation material being used, and periodic safety inspection of all installation material and the fixture, among other skills. If you lack these qualifications, do not attempt the installation yourself. Improper installation can result in bodily injury.

The fixture is fully operational in the following positions: hanging from a horizontal truss, suspended sideways from a vertical truss, or standing upright on a flat, level surface. See the illustration below for reference.

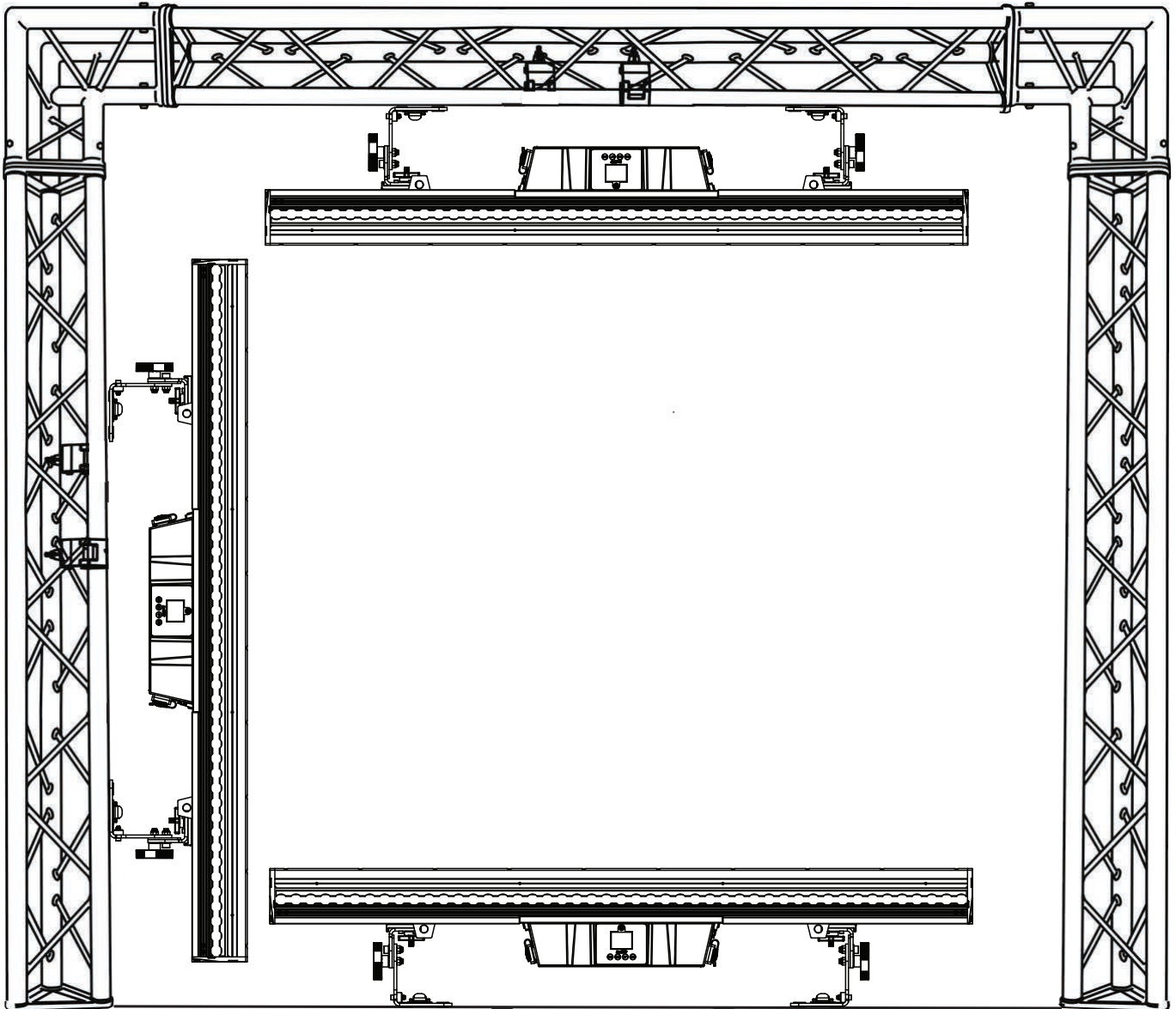

**FALLING FIXTURES CAN CAUSE SEVERE INJURY OR SERIOUS EQUIPMENT DAMAGE! FOR THIS REASON, FIXTURES SHOULD BE INSTALLED AND INSPECTED ONLY BY QUALIFIED PERSONNEL. DO NOT INSTALL THE UNIT IF YOU LACK THE QUALIFICATIONS TO DO SO, OR IF YOU HAVE DOUBTS ABOUT THE SAFETY AND SECURITY OF THE INSTALLATION SETUP OR LOCATION!**



**ALWAYS ATTACH A SAFETY CABLE WHENEVER INSTALLING THIS FIXTURE IN A SUSPENDED ENVIRONMENT TO ENSURE THE FIXTURE WILL NOT FALL IF THE CLAMP FAILS.**

# ACCESSORY INSTALLATION

## L-TRACK MOUNTING

Alternately, this unit's L-track mounting system allows the user to slide the mounting clamps along the tracks and lock them down in the desired position. The L-tracks are located on the top of the unit's body. Special L-track mounting clamps, which incorporate an L-track attachment rail in place of a mounting bolt hole, are available in both regular and extended lengths. Similarly, L-track adapters are also available which can be fitted to any standard mounting clamp.

To attach an L-track clamp or adapter, simply insert the attachment rail into the matching track on the fixture, slide to its desired location, and tighten the fastener knob on the attachment to secure in place.

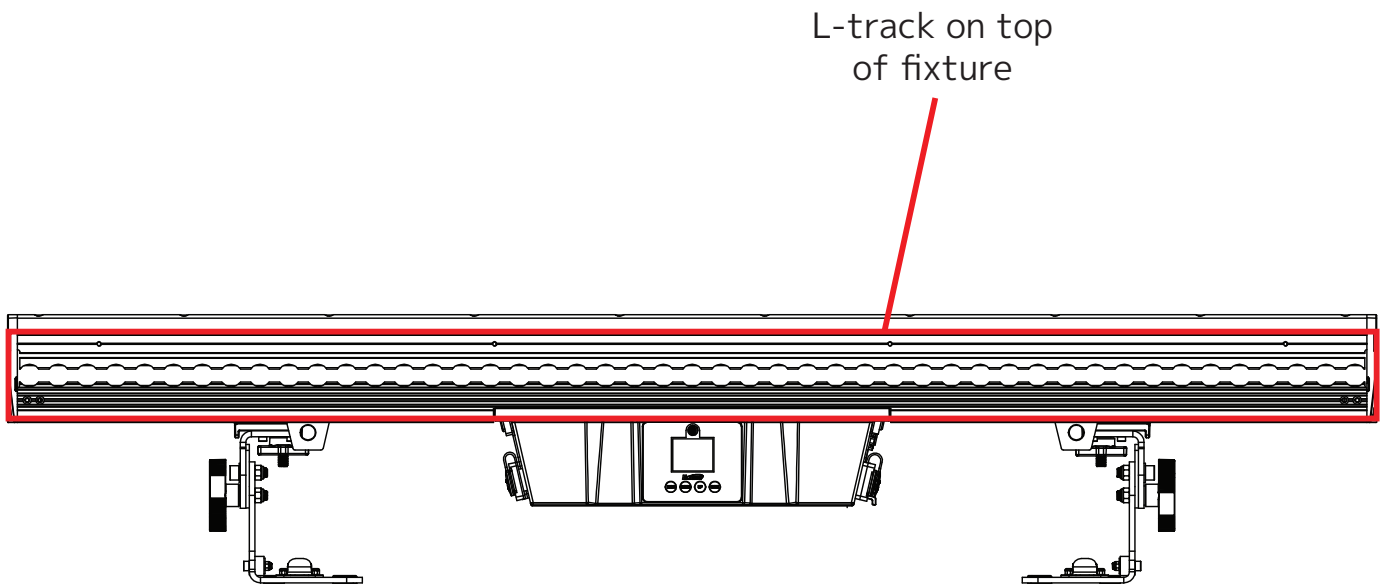
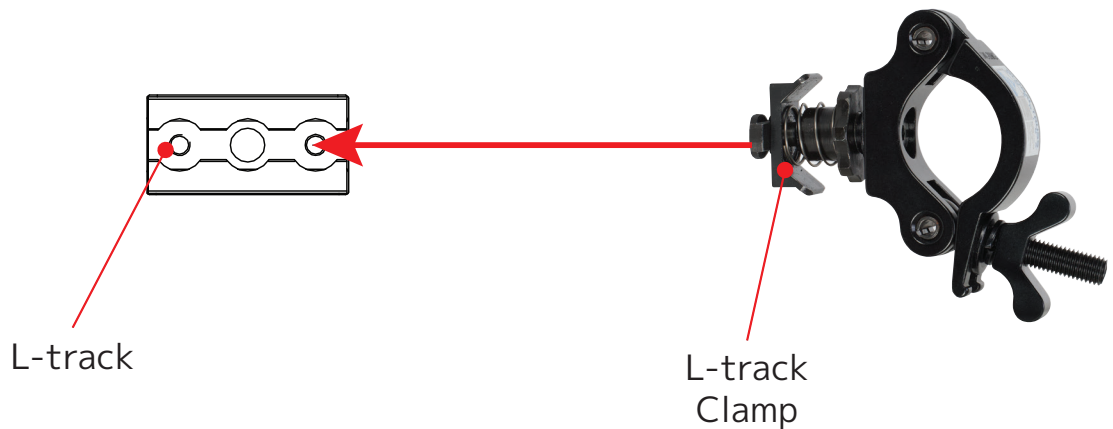

# ACCESSORY INSTALLATION

## BORDER LIGHT FILTER

Raise the positioning border on one side of the fixture's lens frame (1). From the opposite side, slide the border light filter into the slot in the frame (2). Finally, raise the other positioning border to secure the border light filter in place (3).

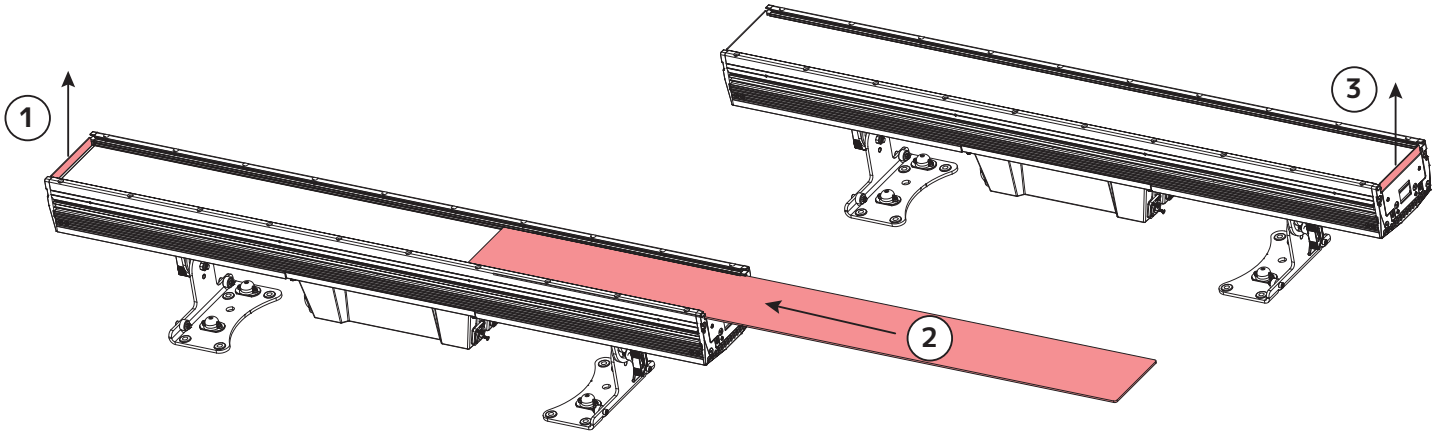

## GLARE SHIELD

Locate the two mounting holes on the side of the fixture for the glare shield, as shown in the below left image. Align the mounting screws of the glare shield with these mounting holes, then tighten these screws to secure the glare shield in place.

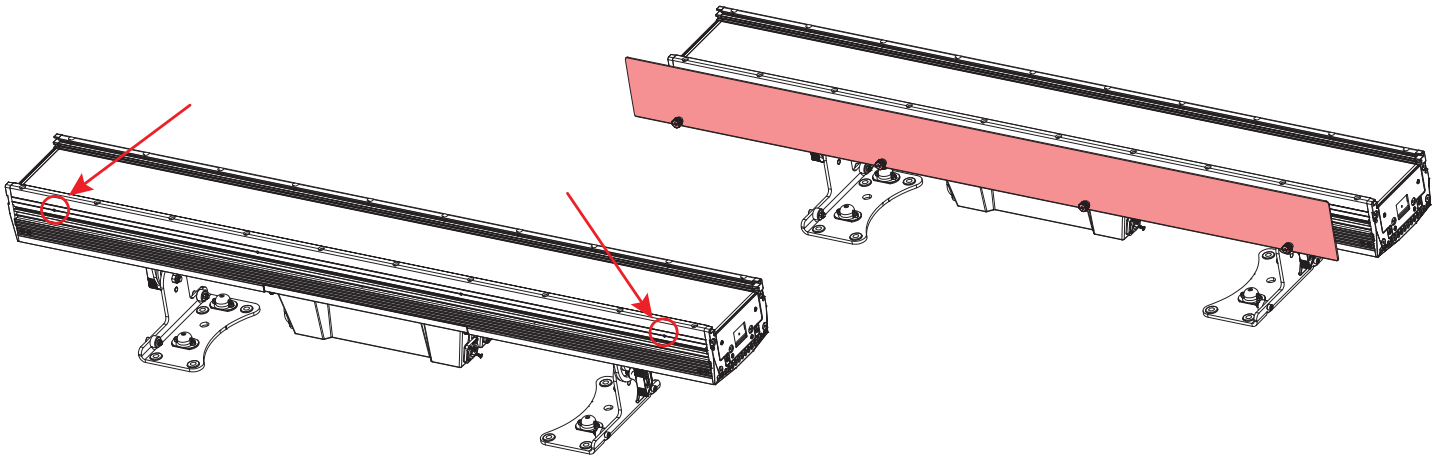

# NEAR FIELD COMMUNICATION (NFC)

Near Field Communication (NFC) is a short-range wireless technology, operating at 13.56 MHz, that enables secure data exchange between devices within a proximity of 6-inches. With NFC, one can use an Android or iOS device to configure an NFC compatible fixture. NFC has three modes of operation: Reader/Writer Mode, which allows an NFC device to read or write data to an NFC tag; Peer-to-Peer Mode, enabling data exchange between two NFC devices; and Card Emulation Mode, which lets an NFC device emulate a contactless smart card. The technology is built on RFID standards, including ISO/IEC 14443 and ISO/IEC 18092, ensuring compatibility between NFC devices. Despite its lower data transfer rates compared to Wi-Fi or Bluetooth, ranging from 106 kbps to 424 kbps, NFC incorporates encryption and authentication protocols. NFC tags on lighting fixtures simplify setup and adjustments, and aid in tracking and maintenance when integrated into lighting equipment.

## NFC Setup and Usage

- Enable NFC: Activate NFC on both the control device and the fixture.
- Physical Proximity: Bring the control device near the designated NFC area of the fixture indicated by the NFC directional mark shown here.



- Initiate Connection: The NFC-enabled device should automatically detect the fixture, prompting a connection notification.
- Confirmation: Accept the connection request to establish a link between the control device and the fixture.
- Configuration Options: Adjust lighting settings, presets, and modes via the control device, depending on fixture capabilities.
- Data Exchange: Use NFC to transfer presets, scenes, and firmware updates between devices, simplifying data sharing.

## Tips for Successful NFC Interaction

- Proximity: Maintain a short-range distance, within 6-inches, between the control device and the indicated NFC area of the fixture.
- Device Compatibility: Ensure your device supports NFC, and has the necessary apps for interaction.
- Interference: Avoid obstacles between the devices, like metal objects, to ensure smooth communication.
- Security: Disable NFC when not in use for added security against unauthorized access.

# ARIA SETUP AND GUIDELINES

**This fixture is equipped with Aria X2. Please note that Aria's wireless functions are switched off by default.** Activate Aria X2 and Bluetooth in the system menu to take advantage of the fixture's wireless feature set for wireless connectivity and over the air software updates.

## 2.4GHZ Versus Sub-Gig (GHz) Frequencies:

Sub-GHz frequencies provide superior reliability and range compared to higher frequencies, making them perfect for consistent communication across vast distances or in difficult conditions. Devices operating in the sub-GHz range, which refers to frequencies below 1 GHz, can transmit signals over significant distances and can penetrate physical barriers such as walls and buildings more effectively. Additionally, these frequencies experience less interference compared to those in the heavily congested 2.4-GHz band, which is commonly used by wireless devices.

In the United States, the 900 MHz band is a versatile frequency range that is utilized by various services, with the FCC overseeing its allocation and regulation.

In the European Union, the 868 MHz frequency is designated by ETSI as the Sub-Gig frequency.

In summary, if an application demands high data rates and more bandwidth in urban or densely populated areas where interference management is feasible, the 2.4 GHz frequency is a suitable choice. On the other hand, for applications requiring long-range communication and better obstacle penetration, particularly in rural or industrial settings with fewer regulatory constraints, a sub-GHz frequency (<1 GHz) is a better option.

## Installation Recommendations:

With the many factors that affect and/or interrupt a wireless signal such as walls, glass, metal, objects, and people, it is highly recommended to:

- Install devices a minimum of 9.8 ft. (3m) above audiences and/or ground level where practical.
- Adjust the wireless antenna in a vertical upright position
- Position devices in direct line of sight of the controlling device

Careful planning and testing of the selected installation location is critical to ensure optimum and reliable wireless operation.

**9.8 ft (3m)  
Above Ground**

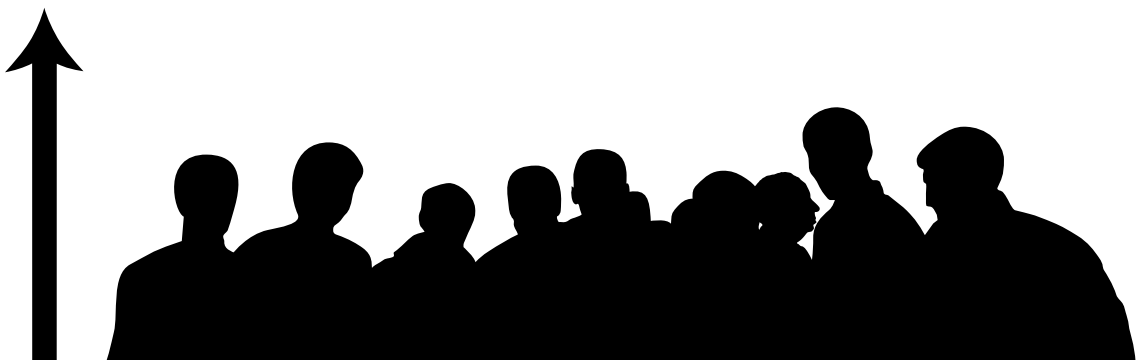

# ARIA SETUP AND GUIDELINES

## GENERAL INFORMATION

The Aria Bluetooth app has the ability to connect wirelessly to any device that has Aria wireless DMX installed and has Bluetooth enabled.

**Before installing the fixture in a remote location, double check that the fixture's main power is switched on, and that the Bluetooth function has been enabled in the fixture's system menu.** Certain fixtures may have Bluetooth disabled by default. If this function is disabled, then the fixture cannot be configured remotely using the Aria app, and will have to be configured directly from the fixture's control screen.

Additionally, the user should consider setting the fixture's No DMX setting to "Hold Last". This will allow the fixture to continue running using the current settings, even if the Aria app device moves out of range, the app is closed, or the signal is otherwise interrupted, minimizing disruption in the operation of the fixtures.

## LEGACY DEVICES

Please note that legacy connected devices, such as those using Wifly, E-Fly, or Magfly, are not compatible with this app. For such legacy devices, the use of a bridge is recommended, as the bridge can communicate with these devices via its SM220 protocol.

The Aria X2 BLE app is currently available from the Apple app store.

## FIXTURE IDENTIFICATION

Aria compatible devices can be identified and connected via the Fixtures tab in the app. This tab displays a field of twenty-four buttons that can be assigned to Aria compatible devices that are within range, and the buttons will automatically be assigned to devices in the order in which they are discovered. If more than twenty-four units are within range, it may be necessary to use the filter feature to search for the desired fixture. Button location can be edited by selecting the configuration key, then the user can drag and drop the buttons to the desired location and hit save to keep changes. Once a device is known to the app, it can also be assigned to a particular button. From that point forward, the assigned device will always be assigned to that button location.

**IMPORTANT NOTE:** For version 0.65 or higher, a shared system password is required to connect to any device.

Unlike wireless DMX, Bluetooth is a connect first protocol. To connect to a device or fixture, tap the assigned button in the Fixtures tab. If the connection is successful, a green frame will appear around the button, indicating that the app was able to retrieve the current channel values from the fixture. The app must be connected to a fixture in order to use its channel controls or view and change settings. Please note that not all Aria devices have channel controls.

Additionally, each fixture can only be connected to one device with the app at any given time. Once a fixture is connected to the app installed on one device, any other devices will be blocked from connecting. As a result, when setting up a new fixture for the first time, best practice is to have only a single user with the app open within range, in order to ensure that the fixture pairs to the intended user's device.

# ARIA SETUP AND GUIDELINES

## DETECTED DEVICES

The second table section shows all Aria devices detected in range. A checkmark indicates the device is currently assigned to a button. If more than 24 devices are within range, the user may remove or add devices to the buttons list by tapping a row to check or uncheck a device. If all buttons are full, it will be necessary to uncheck a device before adding another.

Filter: The user can filter which Aria devices get button assignments by tapping “filter” at the top of the view. A popup will appear where the user can enter text to filter devices by username, model name, or manufacturer. **Please note that these searches are case sensitive.**

Note: If a device shows an asterisk (\*) it means that there is no fixture profile currently available, and therefore there will be limited support available for that device. The user will still be able to connect and adjust channels if the device supports that feature, but the user will not be able to view how many channels the device has or the channel names.

## SECURITY

Each fixture must have a password saved to be secure. When a new fixture is installed for the first time, its password will automatically be set to the app’s system password on first connection. Once the password has been entered, the user will need to exit out to the main page containing the fixture buttons, then de-select and re-select the fixture to lock in the password. From that point forward only, controlling devices that use the correct password can connect to this fixture. **This security is now required by law in most jurisdictions.**

The app will detect any Aria capable fixture within range, even if the app does not have the password to that fixture and therefore cannot access that fixture. If that fixture is selected in the app, the green frame will momentarily appear around that fixture’s button, but then disappear. This indicates that the fixture is visible but inaccessible.

# REMOTE DEVICE MANAGEMENT (RDM)

**NOTE: In order for RDM to work properly, RDM enabled equipment must be used throughout the entire system, including DMX data splitters and wireless systems.**

Remote Device Management (RDM) is a protocol that sits on top of the DMX512 data standard for lighting, allowing the DMX systems of the device to be managed, modified, and monitored remotely (hence, remote device management). This protocol is ideal for fixtures installed in locations that are not easily accessible.

With RDM, the DMX512 system becomes bi-directional, allowing a compatible RDM enabled controller to send out a signal to devices on the wire, as well as allowing the fixture to respond (known as a GET command). The controller can then use it's SET command to modify settings that would typically have to be changed or viewed directly via the unit's display screen, including the DMX Address, DMX Channel Mode, and Temperature Sensors.

## FIXTURE RDM INFORMATION:

RDM Code	Device ID	Device Model ID	Personality ID
0x22A6	0x006D	109	1ch, 3ch-A , 4ch-A , 4ch-B, 3ch-B, 6ch-A, 10ch, 14ch , 22ch, 16ch-A, 6ch-B, 8ch, 6ch-C, 20ch-A, 20ch-B, 35ch, 12ch-A, 16ch-B, 12ch-B, 40ch, 32ch-A, 61ch, 24ch-A, 32ch-B, 24ch-B, 80ch, 56ch, 113ch, 48ch-A, 64ch, 48ch-B, 160ch, 104ch, 217ch

**Please be aware that not all RDM devices support all RDM features**, and therefore it is important to check beforehand to ensure that the equipment that you are considering includes all of the features that you require.

The following parameters are accessible in RDM on this device:

CODE	PARAMETER	CODE	PARAMETER
0x0200	Sensor Definition	0x00C1	Boot Software Version ID
0x0201	Sensor Value	0x0070	Product Detail ID List
0x0080	Device Model Description	0x0500	Display Invert
0x0081	Manufacturer Label	0x0400	Device Hours
0x0082	Device Label	0x0343	Curve
0x00E0	DMX Personality	0x0344	Curve Description
0x00E1	DMX Personality Description	0x0345	Output Response Time
0x0090	Factory Defaults	0x0346	Output Response Time Description
0x0020	Queued Message	0x00F0	DMX Start Address
0x0122	Default Slot Value	0x0050	Supported Parameters
0x00C2	Boot Software Version Label		

# CONTROL PANEL

The fixture includes an easy to navigate system menu. The touch control panel display located on the rear of the fixture (illustrated below) provides access to the main system menu where all necessary system adjustments are made to the fixture.

- Navigate through the main menu options with the **MODE** button.
- Once you reach the desired menu option, press the **ENTER** button to activate that field. Use the **DOWN** and **UP** buttons to adjust the field or to select from the sub-menus, if applicable.
- Pressing the **ENTER** button once more will confirm the setting.
- Exit to the previous menu at any time without making any adjustments by pressing the **MODE** button.

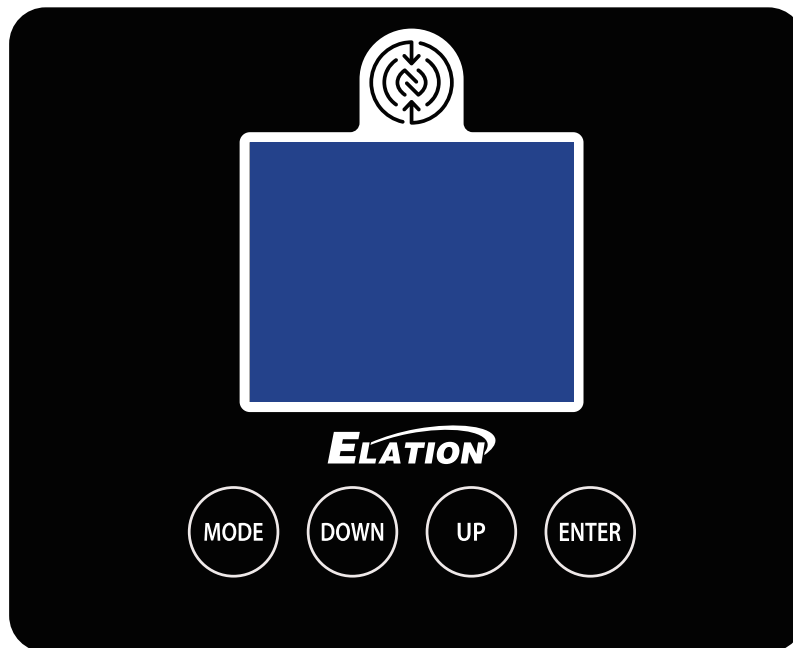

## KEY LOCK

The control keys can be configured to lock after a pre-set period of inactivity. By default, the keys will lock after 1 minute of inactivity, but this setting can be configured to activate after a period of inactivity ranging from 10 seconds and 5 minutes, or disabled entirely so that the keys will always remain unlocked. To change this setting, use the control panel keys to navigate to Settings > Display > Screen Lock in the system menu, then use the UP and DOWN keys to select your desired value. Press the ENTER button to confirm your selection. **To unlock the controls, press UP, DOWN, UP, DOWN, ENTER.**

# SYSTEM MENU

MAIN MENU	OPTIONS / VALUES (Default Settings in <b>BOLD</b> )	
<b>DMX</b>	DMX Address	<b>001</b> - 512
	DMX Mode	<b>1Ch Dimmer</b>
		3Ch RGB
		4Ch RGBA
		4Ch Dimmer/CCT
		3Ch HSI
		6Ch HSIC
		10Ch RGBMA
		14Ch Standard
		22Ch Extended
		16Ch xy Extended
		6Ch RGB 2 Cell
		8Ch RGBA 2 Cell
		6Ch HSI 2 Cell
		20Ch RGBMA 2 Cell
		20Ch Standard 2 Cell
		35Ch Extended 2 Cell
		12Ch RGB 4 Cell
		16Ch RGBA 4 Cell
		12Ch HSI 4 Cell
		40Ch RGBMA 4 Cell
		32Ch Standard 4 Cell
		61Ch Extended 4 Cell
		24Ch RGB 8 Cell
		32Ch RGBA 8 Cell
		24Ch HSI 8 Cell
		80Ch RGBMA 8 Cell
		56Ch Standard 8 Cell
	113Ch Extended 8 Cell	
	48Ch RGB 16 Cell	
64Ch RGBA 16 Cell		
48Ch HSI 16 Cell		
160Ch RGBMA 16 Cell		
104Ch Standard 16 Cell		
217Ch Extended 16 Cell		
No DMX Status	<b>Hold Last</b>	
	Fade to Black	
	Standalone	
	Ethernet Switch to DMX Input	

# SYSTEM MENU

MAIN MENU	OPTIONS / VALUES (Default Settings in <b>BOLD</b> )			
DMX	Protocol	Select Signal	<b>DMX</b> Art-Net sACN Aria In - DMX Out DMX In - Aria Out	
		Universe	0 - 32767 ( <b>Default = 1</b> )	
		IP Address	<b>Manual: X.X.X.X</b> DHCP	
			Unique Static: 2.X.X.X; 10.X.X.X; 172.X.X.X; 192.X.X.X	
		Subnet Mask	<b>255.0.0.0</b>	
		Ethernet DMX Out	<b>Off</b> / On	
	Aria	Enable Aria	<b>Off</b> / On	
		Frequency	<b>2.4Ghz</b> Sub Gig - US Sub Gig - EU	
			2.4GHz Chan	<b>00</b> - 15
			Sub Gig Chan	<b>00</b> - 09
		Enable Mesh	<b>Off</b> / On	
		Enable Bluetooth	<b>Off</b> / On	
		CONTROL	Dimmer	0% - <b>100%</b>
	Manual Control		Red	0 - <b>255</b>
Green			0 - <b>255</b>	
Blue			0 - <b>255</b>	
Mint			0 - <b>255</b>	
Amber			0 - <b>255</b>	
CCT			2400K - 8500K (Default = <b>6000K</b> )	
Green Shift			-100% to +100% (Default = <b>0</b> )	
Virtual Colors	See Color Macros Table			
Primary	On / <b>Off</b>			
Secondary	On / <b>Off</b>			
Self Test	All			
	Dimmer			
	Color			

# SYSTEM MENU

MAIN MENU	OPTIONS / VALUES (Default Settings in <b>BOLD</b> )	
<b>SETTINGS</b>	Dim Modes	<b>Standard</b>
		Stage
		TV
		Architectural
		Theatre
		Stage 2
	Dim Speed	0s - 10s (Default = <b>0.1s</b> )
	Dim to Warm	On / <b>Off</b>
	Dim Curves	Linear
		Square
		Square Inverse
		<b>S-Curve</b>
	LED Refresh Rate	900Hz - 1500Hz, 2500Hz, 4000Hz, 5000Hz, 6000Hz, 10KHz, 15KHz, 20KHz, 25KHz (Default = <b>1200Hz</b> )
	Color Tuning	Highest Fidelity
		Balanced Output and Fidelity
		<b>Highest Output</b>
	Output Balance	<b>Bright (Highest Output)</b>
		Uniform (Elation Full Spectrum Match)
	Max Power Draw	400W
		575W
		<b>800W</b>
	LED Power Limit	50%
		60%
		70%
		80%
		90%
		<b>100%</b>
	Pixel Flip	Yes / <b>No</b>
	Cell Layout	<b>Default</b> / Split
	Fan Mode	<b>Auto</b>
High		
Silent		
Mute		
Display	Screen Delay	10s - 5min (Default = <b>1min</b> )
	Screen Lock	Off, 10s - 5min, <b>Key Lock</b>
	Rotate Display	Yes / <b>No</b> / Auto
Reset User Defaults	Yes / <b>No</b>	

# SYSTEM MENU

MAIN MENU	OPTIONS / VALUES (Default Settings in <b>BOLD</b> )	
<b>INFORMATION</b>	Time	Current Run Time
		Total Run Time
		Last Run Time
	Temperature	Current
		Max Resettable
	Humidity	xxx %
	DMX Values	Red
		Green
		...
	Product IDs	RDM UID
Error Logs	Fixture Errors	
Software Version	Vx.x	
Fixture MAC Address	xx:xx:xx:xx:xx:xx	
<b>SERVICE</b> (Passcode = 050)	Calibration	Red 000 - 255
		Green 000 - 255
		Blue 000 - 255
		Mint 000 - 255
		Amber 000 - 255
		...
		Red16 000 - 255
		Green16 000 - 255
		Blue16 000 - 255
		Mint16 000 - 255
		Amber16 000 - 255
	Record User Defaults	Yes / <b>No</b>
	Reset Factory Defaults	Yes / <b>No</b>
	Reset Last Run	Yes / No
	Reset Error Logs	Yes / No

# FAN MODES

The KL Batten 48 is a high-performance fixture suited for multiple applications. For noise critical environments such as Theater, Opera or Orchestra Halls, it offers various fan operation modes which remove any distraction for the audience and performers. Fan Modes can be changed remotely via the DMX control channel, allowing the fixture to offer high output or whisper silent operation at a moment's notice. All Fan Modes smoothly transition over a brief time, preventing unwanted attraction to the fixture.

**Auto (Default)**—Fans only run at the speeds needed to keep the LED engine within a safe temperature range and ensures optimal performance of the fixture. If possible, they will turn-off, for example, when the fixture is dimmed to a low intensity. Fans sense the ambient and fixture temperature, and will always try to keep noise levels to a minimum. The fixture output will only reduce when the LED engine cannot be cooled down to its safe operating range due to high ambient temperature.

**NOTE: Recommended for daily operation.**

**High**—Fan speeds are increased throughout for the most efficient cooling of the fixture. This mode will increase wear on the fans and should only be utilized in exceptional circumstances. Fans will always run, even if the fixture is dimmed down. Fixture output is kept at 100% unless the LED engine temperature reaches an unsafe temperature at which point the fixture will reduce power carefully to ensure continued safe operation. This mode is only required in very high ambient temperatures when automatic fan speed adjustments are not desired.

## Low Noise Modes

For very critical noise environments, the fixture offers two additional Low Noise Modes for silent operation. The fixture output will be reduced, yet due to the extremely high luminous flux, the fixture still offers outstanding performance. In Low Noise Modes, all parameters of the fixture operate more quietly with reduced fan speeds.

**Silent** - 75-80% max output, fans run at low speed.

**Mute** – All but one fixture fan is turned off for whisper-quiet operation. The fixture LED power output is reduced to 25%.

# DMX TRAITS

**PLEASE NOTE:** Due to the number of DMX channel modes available on this fixture, the chart on the following pages has been divided into three sections for ease of readability. If you are unable to locate information regarding the channel that you are looking for, please ensure that you are reviewing the correct section of the DMX Traits table. The sections and their respective contents are listed below:

## Single Cell:

- 1Ch Dimmer
- 3Ch RGB (3Ch-A)
- 4Ch RGBA (4Ch-A)
- 4Ch Dimmer/CCT (4Ch-B)
- 3Ch HSI (3Ch-B)
- 6Ch HSIC (6Ch-A)
- 10Ch RGBMA
- 14Ch Standard
- 22Ch Extended
- 16Ch xy Extended (16Ch-A)

## 2 Cell:

- 6Ch RGB 2-cell (6Ch-B)
- 8Ch RGBA 2-cell
- 6Ch HSI 2-cell (6Ch-C)
- 20Ch RGBMA 2-cell (20Ch-A)
- 20Ch Standard 2-cell (20Ch-B)
- 35Ch Extended 2-cell

## 4 Cell:

- 12Ch RGB 4-cell (12Ch-A)
- 16Ch RGBA 4-cell (16Ch-B)
- 12Ch HSI 4-cell (12Ch-B)
- 40Ch RGBMA 4-cell
- 32Ch Standard 4-cell (32Ch-A)
- 61Ch Extended 4-cell

## 8 Cell:

- 24Ch RGB 8-cell (24Ch-A)
- 32Ch RGBA 8-cell (32Ch-B)
- 24Ch HSI 8-cell (24Ch-B)
- 80Ch RGBMA 8-cell
- 56Ch Standard 8-cell
- 113Ch Extended 8-cell

## 16 Cell:

- 48Ch RGB 16-cell (48Ch-A)
- 64Ch RGBA 16-cell
- 48Ch HSI 16-cell (48Ch-B)
- 160Ch RGBMA 16-cell
- 104Ch Standard 16-cell
- 217Ch Extended 16-cell

# DMX TRAITS (SINGLE CELL)

MODE/CHANNEL										DMX VALUES	FUNCTION	SNAP	DEF VAL
1 ch	3 ch A	4 ch A	4 ch B	3 ch B	6 ch A	10 ch	14 ch	22 ch	16 ch A				
1			1				1	1	1	000 - 255	<b>Dimmer</b> Intensity, 0 - 100%		0
			2				2	2	2	000 - 255	<b>Dimmer Fine</b> Fine intensity control		0
							3	3	3	000 - 031	<b>Shutter/Strobe</b> Shutter closed		50
										032 - 063	No function (shutter open)		
										064 - 095	Strobe effect, slow to fast		
										096 - 127	No function (shutter open)		
										128 - 159	Pulse effect in sequences		
										160 - 191	No function (shutter open)		
										192 - 223	Random strobe effect, slow to fast		
										224 - 225	No function (shutter open)		
										226 - 253	Random pixel, slow to fast		
										254 - 255	No function (shutter open)		
	1	1				1	4	4		000 - 255	<b>Red</b> 0 - 100%		
						2		5		000 - 255	<b>Red Fine</b> Fine adjustment		
	2	2				3	5	6		000 - 255	<b>Green</b> 0 - 100%		
						4		7		000 - 255	<b>Green Fine</b> Fine adjustment		
	3	3				5	6	8		000 - 255	<b>Blue</b> 0 - 100%		
						6		9		000 - 255	<b>Blue Fine</b> Fine adjustment		
						7	7	10		000 - 255	<b>Mint</b> 0 - 100%		
						8		11		000 - 255	<b>Mint Fine</b> Fine adjustment		

# DMX TRAITS (SINGLE CELL)

MODE/CHANNEL										DMX VALUES	FUNCTION	SNAP	DEF VAL
1 ch	3 ch A	4 ch A	4 ch B	3 ch B	6 ch A	10 ch	14 ch	22 ch	16 ch A				
		4				9	8	12			<b>Amber</b>		
										000 - 255	0 - 100%		
						10		13			<b>Amber Fine</b>		
										000 - 255	Fine adjustment		
				1	1						<b>Hue</b>		0
										000 - 255	0 to 360°		
					2						<b>Hue Fine</b>		0
										000 - 255	0 to 360°		
				2	3						<b>Saturation</b>		0
										000 - 255	0 to 100%		
				3	4						<b>Dimmer 1</b>		0
										000 - 255	Intensity 0 to 100%		
									4		<b>x Coordinate</b>		0
										000 - 255	0 to 100%		
									5		<b>x Coordinate Fine</b>		0
										000 - 255	Fine adjustment		
									6		<b>y Coordinate</b>		0
										000 - 255	0 to 100%		
									7		<b>y Coordinate Fine</b>		0
										000 - 255	Fine adjustment		
			3		5		9				<b>CCT Presets</b>		
										000 - 023	Open	X	0
										024 - 085	2400K to 8500K (see Color Temperature Table)		
										086 - 255	8500K		
								14	8		<b>Variable CCT</b>		0
										000 - 023	Open		
										024 - 255	2400K to 8500K		
								15	9		<b>Variable CCT Fine</b>		0
										000 - 255	Fine adjustment		
			4		6			16	10		<b>Green Shift</b>		0
										000	Idle		
										001 - 127	Full Minus Green to Neutral		
										128	Neutral White		
										129 - 255	Neutral to Full Plus Green		

# DMX TRAITS (SINGLE CELL)

MODE/CHANNEL										DMX VALUES	FUNCTION	SNAP	DEF VAL	
1 ch	3 ch A	4 ch A	4 ch B	3 ch B	6 ch A	10 ch	14 ch	22 ch	16 ch A					
							10	17	11		<b>Color</b>		0	
										000	Open			
										001 - 179	Virtual Swatch Book (See Virtual Colors Table)			
											<b>Color Scroll</b>			
										180 - 201	Clockwise, fast to slow			
										202 - 207	Stop			
										228 - 229	Counter-clockwise, slow to fast			
										230 - 234	Open			
							10	17	11		<b>Random Slots</b>		0	
										235 - 239	Fast			
										240 - 244	Medium			
										245 - 249	Slow			
										250 - 255	Open			
							11	18	12		<b>Effect Selection</b>	X	0	
										000 - 255	FX Selection, 1 - 255 (see table)			
							12	19	13		<b>Effect Speed</b>		0	
										000 - 126	Fast to slow			
										127 - 128	Stop			
										129 - 255	Slow to fast			
							13	20	14		<b>Effect Offset</b>	X	0	
										000	Idle			
										001 - 035	Fixture Offset, 10° to 350°			
										036	Synchronized			
										037 - 049	Random Fixture Offset			
										050 - 059	Random Pixel Order			
										060 - 069	Random Steps			
										070 - 079	Idle			
											<b>Effect Fade</b>			
										080 - 089	Sinewave - Cross			
										090 - 099	Sinewave - Full			
										100 - 109	Sawtooth - Cross			
										110 - 119	Sawtooth - Full			
										120 - 129	Ramp Up			
										130 - 139	Ramp Down			
										140 - 149	Steps			
										150 - 255	Idle			

# DMX TRAITS (SINGLE CELL)

MODE/CHANNEL										DMX VALUES	FUNCTION	SNAP	DEF VAL
1 ch	3 ch A	4 ch A	4 ch B	3 ch B	6 ch A	10 ch	14 ch	22 ch	16 ch A				
								21	15		<b>Dim Modes</b>	X	0
										000 - 020	Standard		
										021 - 040	Stage		
										041 - 060	TV		
										061 - 080	Architectural		
										081 - 100	Theatre		
										101 - 120	Stage 2		
								21	15		<b>Dimmer Delay Time</b>	X	0
										121	0s		
										122	0.1s		
										123	0.2s		
										124	0.3s		
										125	0.4s		
										126	0.5s		
										127	0.6s		
										128	0.7s		
										129	0.8s		
										130	0.9s		
										131	1.0s		
										132	1.5s		
										133	2.0s		
										134	3.0s		
										135	4.0s		
										136	5.0s		
										137	6.0s		
										138	7.0s		
										139	8.0s		
										140	9.0s		
										141	10s		
										142 - 149	Idle		
											<b>Dim to Warm</b>		
										150 - 154	DTW On		
										155 - 159	DTW Off (default)		
										160 - 255	Idle		



# DMX TRAITS (SINGLE CELL)

MODE/CHANNEL										DMX VALUES	FUNCTION	SNAP	DEF VAL	
1 ch	3 ch A	4 ch A	4 ch B	3 ch B	6 ch A	10 ch	14 ch	22 ch	16 ch A					
											Refresh Rate (Hz) (continued)			
											126	1160		
											127	1170		
											128	1180		
											129	1190		
											130	1200 (default)		
											131	1210		
											132	1220		
											133	1230		
											134	1240		
											135	1250		
											136	1260		
											137	1270		
											138	1280		
											139	1290		
											140	1300		
											141	1310		
											142	1320		
							14	22	16		143	1330	X	0
											144	1340		
											145	1350		
											146	1360		
											147	1370		
											148	1380		
											149	1390		
											150	1400		
											151	1410		
											152	1420		
											153	1430		
											154	1440		
											155	1450		
											156	1460		
											157	1470		
											158	1480		
											159	1490		
											160	1500		
											161	2500		
											162	4000		

# DMX TRAITS (SINGLE CELL)

MODE/CHANNEL										DMX VALUES	FUNCTION	SNAP	DEF VAL
1 ch	3 ch A	4 ch A	4 ch B	3 ch B	6 ch A	10 ch	14 ch	22 ch	16 ch A				
											<b>Refresh Rate (Hz) (continued)</b>		
										163	5000		
										164	6000		
										165	10000		
										166	15000		
										167	20000		
										168	25000		
										169 - 174	Idle		
											<b>Color Tuning</b>		
										175 - 176	Highest Fidelity		
							14	22	16	177 - 178	Balanced Output and Fidelity	X	0
										179 - 180	Highest Output (default)		
											<b>Output Balance</b>		
										181 - 182	Bright (Highest Output) (default)		
										183 - 184	Uniform (Elation Full Spectrum Match)		
										185 - 200	Idle		
											<b>Dimmer Curves</b>		
										201 - 210	Linear		
										211 - 220	Square		
										221 - 230	Inverse Square		
										231 - 240	S-Curve (default)		
										241 - 255	Idle		

# DMX TRAITS (2 CELL)

MODE/CHANNEL						DMX VALUES	FUNCTION	SNAP	DEF VAL	
6 ch B	8 ch	6 ch C	20 ch A	20 ch B	35 ch					
				1	1		<b>Dimmer</b>		0	
						000 - 255	Intensity, 0 - 100%			
				2	2		<b>Dimmer Fine</b>		0	
						000 - 255	Fine intensity control			
				3	3		<b>Shutter/Strobe</b>		50	
						000 - 031	Shutter closed			
						032 - 063	No function (shutter open)			
						064 - 095	Strobe effect, slow to fast			
						096 - 127	No function (shutter open)			
						128 - 159	Pulse effect in sequences			
						160 - 191	No function (shutter open)			
						192 - 223	Random strobe effect, slow to fast			
						224 - 225	No function (shutter open)			
						226 - 253	Random pixel, slow to fast			
				254 - 255	No function (shutter open)					
1	1		1	4	4		<b>Red</b>			
						000 - 255	0 - 100%			
			2		5		<b>Red Fine</b>			
						000 - 255	Fine adjustment			
2	2		3	5	6		<b>Green</b>			
						000 - 255	0 - 100%			
			4		7		<b>Green Fine</b>			
						000 - 255	Fine adjustment			
3	3		5	6	8		<b>Blue</b>			
						000 - 255	0 - 100%			
			6		9		<b>Blue Fine</b>			
						000 - 255	Fine adjustment			
			7	7	10		<b>Mint</b>			
						000 - 255	0 - 100%			
			8		11		<b>Mint Fine</b>			
						000 - 255	Fine adjustment			
	4		9	8	12		<b>Amber</b>			
						000 - 255	0 - 100%			
			10		13		<b>Amber Fine</b>			
						000 - 255	Fine adjustment			
4	5		11	9	14		<b>Red 2</b>			
						000 - 255	0 - 100%			
			12		15		<b>Red 2 Fine</b>			
						000 - 255	Fine adjustment			

# DMX TRAITS (2 CELL)

MODE/CHANNEL						DMX VALUES	FUNCTION	SNAP	DEF VAL
6 ch B	8 ch	6 ch C	20 ch A	20 ch B	35 ch				
5	6		13	10	16		<b>Green 2</b>		
						000 - 255	0 - 100%		
			14		17		<b>Green 2 Fine</b>		
						000 - 255	Fine adjustment		
6	7		15	11	18		<b>Blue 2</b>		
						000 - 255	0 - 100%		
			16		19		<b>Blue 2 Fine</b>		
						000 - 255	Fine adjustment		
			17	12	20		<b>Mint 2</b>		
						000 - 255	0 - 100%		
			18		21		<b>Mint 2 Fine</b>		
						000 - 255	Fine adjustment		
	8		19	13	22		<b>Amber 2</b>		
						000 - 255	0 - 100%		
			20		23		<b>Amber 2 Fine</b>		
						000 - 255	Fine adjustment		
		1					<b>Hue</b>		0
						000 - 255	0 to 360°		
		2					<b>Saturation</b>		0
						000 - 255	0 to 100%		
		3					<b>Dimmer 1</b>		0
						000 - 255	Intensity 0 to 100%		
		4					<b>Hue 2</b>		0
						000 - 255	0 to 360°		
		5					<b>Saturation 2</b>		0
						000 - 255	0 to 100%		
		6					<b>Dimmer 2</b>		0
						000 - 255	Intensity 0 to 100%		
				14			<b>CCT Presets</b>	X	0
						000 - 023	Open		
						024 - 085	2400K to 8500K (see Color Temperature Table)		
				15			<b>CCT Presets 2</b>	X	0
						000 - 023	Open		
						024 - 085	2400K to 8500K (see Color Temperature Table)		
						086 - 255	8500K		

# DMX TRAITS (2 CELL)

MODE/CHANNEL						DMX VALUES	FUNCTION	SNAP	DEF VAL	
6 ch B	8 ch	6 ch C	20 ch A	20 ch B	35 ch					
					24		<b>Variable CCT</b>		0	
						000 - 023	Open			
						024 - 255	2400K to 8500K			
					25		<b>Variable CCT Fine</b>		0	
						000 - 255	Fine adjustment			
					26		<b>Variable CCT 2</b>		0	
						000 - 023	Open			
						024 - 255	2400K to 8500K			
					27		<b>Variable CCT Fine 2</b>		0	
						000 - 255	Fine adjustment			
					28		<b>Green Shift</b>		0	
						000	Idle			
						001 - 127	Full Minus Green to Neutral			
						128	Neutral White			
					129 - 255	Neutral to Full Plus Green				
					29		<b>Green Shift 2</b>		0	
						000	Idle			
						001 - 127	Full Minus Green to Neutral			
						128	Neutral White			
					129 - 255	Neutral to Full Plus Green				
				16	30		<b>Color</b>		0	
							000			Open
							001 - 179			Virtual Swatch Book (See Virtual Colors Table)
										<b>Color Scroll</b>
							180 - 201			Clockwise, fast to slow
							202 - 207			Stop
							228 - 229			Counter-clockwise, slow to fast
							230 - 234			Open
										<b>Random Slots</b>
							235 - 239			Fast
							240 - 244			Medium
							245 - 249			Slow
					250 - 255	Open				
				17	31		<b>Effect Selection</b>	X	0	
							000 - 255			FX Selection, 1 - 255 (see table)
				18	32		<b>Effect Speed</b>		0	
							000 - 126			Fast to slow
							127 - 128			Stop
							129 - 255			Slow to fast

# DMX TRAITS (2 CELL)

MODE/CHANNEL						DMX VALUES	FUNCTION	SNAP	DEF VAL
6 ch B	8 ch	6 ch C	20 ch A	20 ch B	35 ch				
				19	33		<b>Effect Offset</b>	X	0
						000	Idle		
						001 - 035	Fixture Offset, 10° to 350°		
						036	Synchronized		
						037 - 049	Random Fixture Offset		
						050 - 059	Random Pixel Order		
						060 - 069	Random Steps		
						070 - 079	Idle		
							<b>Effect Fade</b>		
						080 - 089	Sinewave - Cross		
						090 - 099	Sinewave - Full		
						100 - 109	Sawtooth - Cross		
						110 - 119	Sawtooth - Full		
						120 - 129	Ramp Up		
						130 - 139	Ramp Down		
						140 - 149	Steps		
						150 - 255	Idle		
					34		<b>Dim Modes</b>	X	0
						000 - 020	Standard		
						021 - 040	Stage		
						041 - 060	TV		
						061 - 080	Architectural		
						081 - 100	Theatre		
						101 - 120	Stage 2		
							<b>Dimmer Delay Time</b>		
						121	0s		
						122	0.1s		
						123	0.2s		
						124	0.3s		
						125	0.4s		
						126	0.5s		
						127	0.6s		
						128	0.7s		
						129	0.8s		
130	0.9s								
131	1.0s								
132	1.5s								
133	2.0s								
134	3.0s								

# DMX TRAITS (2 CELL)

MODE/CHANNEL						DMX VALUES	FUNCTION	SNAP	DEF VAL	
6 ch B	8 ch	6 ch C	20 ch A	20 ch B	35 ch					
					34		<b>Dimmer Delay Time (continued)</b>	X	0	
						135	4.0s			
						136	5.0s			
						137	6.0s			
						138	7.0s			
						139	8.0s			
						140	9.0s			
						141	10s			
						142 - 149	Idle			
							<b>Dim to Warm</b>			
						150 - 154	DTW On			
						155 - 159	DTW Off (default)			
						160 - 255	Idle			
				20		35				<b>Control</b>
							000 - 009	Idle		
							010 - 014	Fan Mode Auto (default)		
							015 - 019	Fan Mode Mute		
							020 - 024	Fan Mode Silent		
							025 - 029	Fan Mode High		
							030 - 049	Idle		
							050 - 054	Default Pixel Order		
							055 - 059	Flip Pixel Order		
							060 - 064	Default Cell Layout		
							065 - 069	Split Cell Layout		
							070 - 099	Idle		
								<b>Refresh Rate (Hz)</b>		
							100	900		
							101	910		
							102	920		
							103	930		
							104	940		
							105	950		
							106	960		
					107	970				
					108	980				
					109	990				
					110	1000				
					111	1010				
					112	1020				

# DMX TRAITS (2 CELL)

MODE/CHANNEL						DMX VALUES	FUNCTION	SNAP	DEF VAL
6 ch B	8 ch	6 ch C	20 ch A	20 ch B	35 ch				
							<b>Refresh Rate (Hz) (continued)</b>		
						113	1030		
						114	1040		
						115	1050		
						116	1060		
						117	1070		
						118	1080		
						119	1090		
						120	1100		
						121	1110		
						122	1120		
						123	1130		
						124	1140		
						125	1150		
						126	1160		
						127	1170		
						128	1180		
						129	1190		
				20	35	130	1200 (default)		
						131	1210	X	0
						132	1220		
						133	1230		
						134	1240		
						135	1250		
						136	1260		
						137	1270		
						138	1280		
						139	1290		
						140	1300		
						141	1310		
						142	1320		
						143	1330		
						144	1340		
						145	1350		
						146	1360		
						147	1370		
						148	1380		
						149	1390		
						150	1400		

# DMX TRAITS (2 CELL)

MODE/CHANNEL						DMX VALUES	FUNCTION	SNAP	DEF VAL
6 ch B	8 ch	6 ch C	20 ch A	20 ch B	35 ch				
							<b>Refresh Rate (Hz) (continued)</b>		
						151	1410		
						152	1420		
						153	1430		
						154	1440		
						155	1450		
						156	1460		
						157	1470		
						158	1480		
						159	1490		
						160	1500		
						161	2500		
						162	4000		
						163	5000		
						164	6000		
						165	10000		
				20	35	166	15000		
						167	20000	X	0
						168	25000		
						169 - 174	Idle		
							<b>Color Tuning</b>		
						175 - 176	Highest Fidelity		
						177 - 178	Balanced Output and Fidelity		
						179 - 180	Highest Output (default)		
							<b>Output Balance</b>		
						181 - 182	Bright (Highest Output) (default)		
						183 - 184	Uniform (Elation Full Spectrum Match)		
						185 - 200	Idle		
							<b>Dimmer Curves</b>		
						201 - 210	Linear		
						211 - 220	Square		
						221 - 230	Inverse Square		
						231 - 240	S-Curve (default)		
						241 - 255	Idle		

# DMX TRAITS (4 CELL)

MODE/CHANNEL						DMX VALUES	FUNCTION	SNAP	DEF VAL
12 ch A	16 ch B	12 ch B	40 ch	32 ch A	61 ch				
				1	1	000 - 255	<b>Dimmer</b> Intensity, 0 - 100%		0
				2	2	000 - 255	<b>Dimmer Fine</b> Fine intensity control		0
				3	3	000 - 031	<b>Shutter/Strobe</b> Shutter closed		50
						032 - 063	No function (shutter open)		
						064 - 095	Strobe effect, slow to fast		
						096 - 127	No function (shutter open)		
						128 - 159	Pulse effect in sequences		
						160 - 191	No function (shutter open)		
						192 - 223	Random strobe effect, slow to fast		
						224 - 225	No function (shutter open)		
						226 - 253	Random pixel, slow to fast		
						254 - 255	No function (shutter open)		
1	1		1	4	4	000 - 255	<b>Red</b> 0 - 100%		
			2		5	000 - 255	<b>Red Fine</b> Fine adjustment		
2	2		3	5	6	000 - 255	<b>Green</b> 0 - 100%		
			4		7	000 - 255	<b>Green Fine</b> Fine adjustment		
3	3		5	6	8	000 - 255	<b>Blue</b> 0 - 100%		
			6		9	000 - 255	<b>Blue Fine</b> Fine adjustment		
			7	7	10	000 - 255	<b>Mint</b> 0 - 100%		
			8		11	000 - 255	<b>Mint Fine</b> Fine adjustment		
	4		9	8	12	000 - 255	<b>Amber</b> 0 - 100%		
			10		13	000 - 255	<b>Amber Fine</b> Fine adjustment		
4	5		11	9	14	000 - 255	<b>Red 2</b> 0 - 100%		
			12		15	000 - 255	<b>Red 2 Fine</b> Fine adjustment		

# DMX TRAITS (4 CELL)

MODE/CHANNEL						DMX VALUES	FUNCTION	SNAP	DEF VAL
12 ch A	16 ch B	12 ch B	40 ch	32 ch A	61 ch				
5	6		13	10	16		<b>Green 2</b>		
						000 - 255	0 - 100%		
			14		17		<b>Green 2 Fine</b>		
						000 - 255	Fine adjustment		
6	7		15	11	18		<b>Blue 2</b>		
						000 - 255	0 - 100%		
			16		19		<b>Blue 2 Fine</b>		
						000 - 255	Fine adjustment		
			17	12	20		<b>Mint 2</b>		
						000 - 255	0 - 100%		
			18		21		<b>Mint 2 Fine</b>		
						000 - 255	Fine adjustment		
	8		19	13	22		<b>Amber 2</b>		
						000 - 255	0 - 100%		
			20		23		<b>Amber 2 Fine</b>		
						000 - 255	Fine adjustment		
7	9		21	14	24		<b>Red 3</b>		
						000 - 255	0 - 100%		
			22		25		<b>Red 3 Fine</b>		
						000 - 255	Fine adjustment		
8	10		23	15	26		<b>Green 3</b>		
						000 - 255	0 - 100%		
			24		27		<b>Green 3 Fine</b>		
						000 - 255	Fine adjustment		
9	11		25	16	28		<b>Blue 3</b>		
						000 - 255	0 - 100%		
			26		29		<b>Blue 3 Fine</b>		
						000 - 255	Fine adjustment		
			27	17	30		<b>Mint 3</b>		
						000 - 255	0 - 100%		
			28		31		<b>Mint 3 Fine</b>		
						000 - 255	Fine adjustment		
	12		29	18	32		<b>Amber 3</b>		
						000 - 255	0 - 100%		
			30		33		<b>Amber 3 Fine</b>		
						000 - 255	Fine adjustment		
10	13		31	19	34		<b>Red 4</b>		
						000 - 255	0 - 100%		
			32		35		<b>Red 4 Fine</b>		
						000 - 255	Fine adjustment		

# DMX TRAITS (4 CELL)

MODE/CHANNEL						DMX VALUES	FUNCTION	SNAP	DEF VAL
12 ch A	16 ch B	12 ch B	40 ch	32 ch A	61 ch				
11	14		33	20	36	000 - 255	<b>Green 4</b> 0 - 100%		
			34		37	000 - 255	<b>Green 4 Fine</b> Fine adjustment		
12	15		35	21	38	000 - 255	<b>Blue 4</b> 0 - 100%		
			36		39	000 - 255	<b>Blue 4 Fine</b> Fine adjustment		
			37	22	40	000 - 255	<b>Mint 4</b> 0 - 100%		
			38		41	000 - 255	<b>Mint 4 Fine</b> Fine adjustment		
	16		39	23	42	000 - 255	<b>Amber 4</b> 0 - 100%		
			40		43	000 - 255	<b>Amber 4 Fine</b> Fine adjustment		
		1				000 - 255	<b>Hue</b> 0 to 360°		0
						000 - 255	<b>Hue Fine</b> 0 to 360°		0
		2				000 - 255	<b>Saturation</b> 0 to 100%		0
		3				000 - 255	<b>Dimmer 1</b> Intensity 0 to 100%		0
		4				000 - 255	<b>Hue 2</b> 0 to 360°		0
		5				000 - 255	<b>Saturation 2</b> 0 to 100%		0
		6				000 - 255	<b>Dimmer 2</b> Intensity 0 to 100%		0
		7				000 - 255	<b>Hue 3</b> 0 to 360°		0
		8				000 - 255	<b>Saturation 3</b> 0 to 100%		0
		9				000 - 255	<b>Dimmer 3</b> Intensity 0 to 100%		0

# DMX TRAITS (4 CELL)

MODE/CHANNEL						DMX VALUES	FUNCTION	SNAP	DEF VAL
12 ch A	16 ch B	12 ch B	40 ch	32 ch A	61 ch				
		10				000 - 255	<b>Hue 4</b> 0 to 360°		0
		11				000 - 255	<b>Saturation 4</b> 0 to 100%		0
		12				000 - 255	<b>Dimmer 4</b> Intensity 0 to 100%		0
				24		000 - 023	<b>CCT Presets</b> Open	X	0
						024 - 085	2400K to 8500K (see Color Temperature Table)		
						086 - 255	8500K		
				25		000 - 023	<b>CCT Presets 2</b> Open	X	0
						024 - 085	2400K to 8500K (see Color Temperature Table)		
						086 - 255	8500K		
				26		000 - 023	<b>CCT Presets 3</b> Open	X	0
						024 - 085	2400K to 8500K (see Color Temperature Table)		
						086 - 255	8500K		
				27		000 - 023	<b>CCT Presets 4</b> Open	X	0
						024 - 085	2400K to 8500K (see Color Temperature Table)		
						086 - 255	8500K		
					44	000 - 023	<b>Variable CCT</b> Open		0
						024 - 255	2400K to 8500K		
					45	000 - 255	<b>Variable CCT Fine</b> Fine adjustment		0
					46	000 - 023	<b>Variable CCT 2</b> Open		0
						024 - 255	2400K to 8500K		
					47	000 - 255	<b>Variable CCT Fine 2</b> Fine adjustment		0
					48	000 - 023	<b>Variable CCT 3</b> Open		0
						024 - 255	2400K to 8500K		
					49	000 - 255	<b>Variable CCT Fine 3</b> Fine adjustment		0

# DMX TRAITS (4 CELL)

MODE/CHANNEL						DMX VALUES	FUNCTION	SNAP	DEF VAL	
12 ch A	16 ch B	12 ch B	40 ch	32 ch A	61 ch					
					50		<b>Variable CCT 4</b>		0	
						000 - 023	Open			
						024 - 255	2400K to 8500K			
					51		<b>Variable CCT Fine 4</b>		0	
						000 - 255	Fine adjustment			
					52		<b>Green Shift</b>		0	
						000	Idle			
						001 - 127	Full Minus Green to Neutral			
						128	Neutral White			
					129 - 255	Neutral to Full Plus Green				
					53		<b>Green Shift 2</b>		0	
						000	Idle			
						001 - 127	Full Minus Green to Neutral			
						128	Neutral White			
					129 - 255	Neutral to Full Plus Green				
					54		<b>Green Shift 3</b>		0	
						000	Idle			
						001 - 127	Full Minus Green to Neutral			
						128	Neutral White			
					129 - 255	Neutral to Full Plus Green				
					55		<b>Green Shift 4</b>		0	
						000	Idle			
						001 - 127	Full Minus Green to Neutral			
						128	Neutral White			
					129 - 255	Neutral to Full Plus Green				
				28	56		<b>Color</b>		0	
							000			Open
							001 - 179			Virtual Swatch Book (See Virtual Colors Table)
										<b>Color Scroll</b>
							180 - 201			Clockwise, fast to slow
							202 - 207			Stop
							228 - 229			Counter-clockwise, slow to fast
							230 - 234			Open
										<b>Random Slots</b>
							235 - 239			Fast
							240 - 244			Medium
							245 - 249			Slow
							250 - 255			Open

# DMX TRAITS (4 CELL)

MODE/CHANNEL						DMX VALUES	FUNCTION	SNAP	DEF VAL
12 ch A	16 ch B	12 ch B	40 ch	32 ch A	61 ch				
				29	57		<b>Effect Selection</b>	X	0
						000 - 255	FX Selection, 1 - 255 (see table)		
				30	58		<b>Effect Speed</b>		0
						000 - 126	Fast to slow		
						127 - 128	Stop		
						129 - 255	Slow to fast		
				31	59		<b>Effect Offset</b>	X	0
						000	Idle		
						001 - 035	Fixture Offset, 10° to 350°		
						036	Synchronized		
						037 - 049	Random Fixture Offset		
						050 - 059	Random Pixel Order		
						060 - 069	Random Steps		
						070 - 079	Idle		
							<b>Effect Fade</b>		
						080 - 089	Sinewave - Cross		
						090 - 099	Sinewave - Full		
						100 - 109	Sawtooth - Cross		
						110 - 119	Sawtooth - Full		
						120 - 129	Ramp Up		
						130 - 139	Ramp Down		
						140 - 149	Steps		
						150 - 255	Idle		
					60		<b>Dim Modes</b>	X	0
						000 - 020	Standard		
						021 - 040	Stage		
						041 - 060	TV		
						061 - 080	Architectural		
						081 - 100	Theatre		
						101 - 120	Stage 2		
							<b>Dimmer Delay Time</b>		
						121	0s		
						122	0.1s		
						123	0.2s		
						124	0.3s		
						125	0.4s		
						126	0.5s		
						127	0.6s		
						128	0.7s		

# DMX TRAITS (4 CELL)

MODE/CHANNEL						DMX VALUES	FUNCTION	SNAP	DEF VAL		
12 ch A	16 ch B	12 ch B	40 ch	32 ch A	61 ch						
					60		<b>Dimmer Delay Time (continued)</b>	X	0		
						129	0.8s				
						130	0.9s				
						131	1.0s				
						132	1.5s				
						133	2.0s				
						134	3.0s				
						135	4.0s				
						136	5.0s				
						137	6.0s				
						138	7.0s				
						139	8.0s				
						140	9.0s				
						141	10s				
						142 - 149	Idle				
							<b>Dim to Warm</b>				
						150 - 154	DTW On				
						155 - 159	DTW Off (default)				
					160 - 255	Idle					
				32	61		<b>Control</b>	X	0		
							000 - 009			Idle	
							010 - 014			Fan Mode Auto (default)	
							015 - 019			Fan Mode Mute	
							020 - 024			Fan Mode Silent	
							025 - 029			Fan Mode High	
							030 - 049			Idle	
							050 - 054			Default Pixel Order	
							055 - 059			Flip Pixel Order	
							060 - 064			Default Cell Layout	
							065 - 069			Split Cell Layout	
							070 - 099			Idle	
										<b>Refresh Rate (Hz)</b>	
							100			900	
							101			910	
							102			920	
							103			930	
							104			940	
					105	950					
					106	960					

# DMX TRAITS (4 CELL)

MODE/CHANNEL						DMX VALUES	FUNCTION	SNAP	DEF VAL
12 ch A	16 ch B	12 ch B	40 ch	32 ch A	61 ch				
							<b>Refresh Rate (Hz) (continued)</b>		
						107	970		
						108	980		
						109	990		
						110	1000		
						111	1010		
						112	1020		
						113	1030		
						114	1040		
						115	1050		
						116	1060		
						117	1070		
						118	1080		
						119	1090		
						120	1100		
						121	1110		
						122	1120		
						123	1130		
						124	1140		
				32	61	125	1150	X	0
						126	1160		
						127	1170		
						128	1180		
						129	1190		
						130	1200 (default)		
						131	1210		
						132	1220		
						133	1230		
						134	1240		
						135	1250		
						136	1260		
						137	1270		
						138	1280		
						139	1290		
						140	1300		
						141	1310		
						142	1320		
						143	1330		
						144	1340		

# DMX TRAITS (4 CELL)

MODE/CHANNEL						DMX VALUES	FUNCTION	SNAP	DEF VAL
12 ch A	16 ch B	12 ch B	40 ch	32 ch A	61 ch				
							<b>Refresh Rate (Hz) (continued)</b>		
						145	1350		
						146	1360		
						147	1370		
						148	1380		
						149	1390		
						150	1400		
						151	1410		
						152	1420		
						153	1430		
						154	1440		
						155	1450		
						156	1460		
						157	1470		
						158	1480		
						159	1490		
						160	1500		
						161	2500		
						162	4000		
				32	61	163	5000		
						164	6000	X	0
						165	10000		
						166	15000		
						167	20000		
						168	25000		
						169 - 174	Idle		
							<b>Color Tuning</b>		
						175 - 176	Highest Fidelity		
						177 - 178	Balanced Output and Fidelity		
						179 - 180	Highest Output (default)		
							<b>Output Balance</b>		
						181 - 182	Bright (Highest Output) (default)		
						183 - 184	Uniform (Elation Full Spectrum Match)		
						185 - 200	Idle		
							<b>Dimmer Curves</b>		
						201 - 210	Linear		
						211 - 220	Square		
						221 - 230	Inverse Square		
						231 - 240	S-Curve (default)		
						241 - 255	Idle		

# DMX TRAITS (8 CELL)

MODE/CHANNEL						DMX VALUES	FUNCTION	SNAP	DEF VAL
24 ch A	32 ch B	24 ch B	80 ch	56 ch	113 ch				
				1	1		<b>Dimmer</b>		0
						000 - 255	Intensity, 0 - 100%		
				2	2		<b>Dimmer Fine</b>		0
						000 - 255	Fine intensity control		
				3	3		<b>Shutter/Strobe</b>		50
						000 - 031	Shutter closed		
						032 - 063	No function (shutter open)		
						064 - 095	Strobe effect, slow to fast		
						096 - 127	No function (shutter open)		
						128 - 159	Pulse effect in sequences		
						160 - 191	No function (shutter open)		
						192 - 223	Random strobe effect, slow to fast		
						224 - 225	No function (shutter open)		
						226 - 253	Random pixel, slow to fast		
				254 - 255	No function (shutter open)				
1	1		1	4	4		<b>Red</b>		
						000 - 255	0 - 100%		
			2		5		<b>Red Fine</b>		
						000 - 255	Fine adjustment		
2	2		3	5	6		<b>Green</b>		
						000 - 255	0 - 100%		
			4		7		<b>Green Fine</b>		
						000 - 255	Fine adjustment		
3	3		5	6	8		<b>Blue</b>		
						000 - 255	0 - 100%		
			6		9		<b>Blue Fine</b>		
						000 - 255	Fine adjustment		
			7	7	10		<b>Mint</b>		
						000 - 255	0 - 100%		
			8		11		<b>Mint Fine</b>		
						000 - 255	Fine adjustment		
	4		9	8	12		<b>Amber</b>		
						000 - 255	0 - 100%		
			10		13		<b>Amber Fine</b>		
						000 - 255	Fine adjustment		
4	5		11	9	14		<b>Red 2</b>		
						000 - 255	0 - 100%		
			12		15		<b>Red 2 Fine</b>		
						000 - 255	Fine adjustment		

# DMX TRAITS (8 CELL)

MODE/CHANNEL						DMX VALUES	FUNCTION	SNAP	DEF VAL
24 ch A	32 ch B	24 ch B	80 ch	56 ch	113 ch				
5	6		13	10	16	000 - 255	<b>Green 2</b> 0 - 100%		
			14		17	000 - 255	<b>Green 2 Fine</b> Fine adjustment		
6	7		15	11	18	000 - 255	<b>Blue 2</b> 0 - 100%		
			16		19	000 - 255	<b>Blue 2 Fine</b> Fine adjustment		
			17	12	20	000 - 255	<b>Mint 2</b> 0 - 100%		
			18		21	000 - 255	<b>Mint 2 Fine</b> Fine adjustment		
	8		19	13	22	000 - 255	<b>Amber 2</b> 0 - 100%		
			20		23	000 - 255	<b>Amber 2 Fine</b> Fine adjustment		
7	9		21	14	24	000 - 255	<b>Red 3</b> 0 - 100%		
			22		25	000 - 255	<b>Red 3 Fine</b> Fine adjustment		
8	10		23	15	26	000 - 255	<b>Green 3</b> 0 - 100%		
			24		27	000 - 255	<b>Green 3 Fine</b> Fine adjustment		
9	11		25	16	28	000 - 255	<b>Blue 3</b> 0 - 100%		
			26		29	000 - 255	<b>Blue 3 Fine</b> Fine adjustment		
			27	17	30	000 - 255	<b>Mint 3</b> 0 - 100%		
			28		31	000 - 255	<b>Mint 3 Fine</b> Fine adjustment		
	12		29	18	32	000 - 255	<b>Amber 3</b> 0 - 100%		
			30		33	000 - 255	<b>Amber 3 Fine</b> Fine adjustment		

# DMX TRAITS (8 CELL)

MODE/CHANNEL						DMX VALUES	FUNCTION	SNAP	DEF VAL
24 ch A	32 ch B	24 ch B	80 ch	56 ch	113 ch				
10	13		31	19	34		<b>Red 4</b>		
						000 - 255	0 - 100%		
			32		35		<b>Red 4 Fine</b>		
						000 - 255	Fine adjustment		
11	14		33	20	36		<b>Green 4</b>		
						000 - 255	0 - 100%		
			34		37		<b>Green 4 Fine</b>		
						000 - 255	Fine adjustment		
12	15		35	21	38		<b>Blue 4</b>		
						000 - 255	0 - 100%		
			36		39		<b>Blue 4 Fine</b>		
						000 - 255	Fine adjustment		
			37	22	40		<b>Mint 4</b>		
						000 - 255	0 - 100%		
			38		41		<b>Mint 4 Fine</b>		
						000 - 255	Fine adjustment		
	16		39	23	42		<b>Amber 4</b>		
						000 - 255	0 - 100%		
			40		43		<b>Amber 4 Fine</b>		
						000 - 255	Fine adjustment		
13	17		41	24	44		<b>Red 5</b>		
						000 - 255	0 - 100%		
			42		45		<b>Red 5 Fine</b>		
						000 - 255	Fine adjustment		
14	18		43	25	46		<b>Green 5</b>		
						000 - 255	0 - 100%		
			44		47		<b>Green 5 Fine</b>		
						000 - 255	Fine adjustment		
15	19		45	26	48		<b>Blue 5</b>		
						000 - 255	0 - 100%		
			46		49		<b>Blue 5 Fine</b>		
						000 - 255	Fine adjustment		
			47	27	50		<b>Mint 5</b>		
						000 - 255	0 - 100%		
			48		51		<b>Mint 5 Fine</b>		
						000 - 255	Fine adjustment		
	20		49	28	52		<b>Amber 5</b>		
						000 - 255	0 - 100%		
			50		53		<b>Amber 5 Fine</b>		
						000 - 255	Fine adjustment		

# DMX TRAITS (8 CELL)

MODE/CHANNEL						DMX VALUES	FUNCTION	SNAP	DEF VAL
24 ch A	32 ch B	24 ch B	80 ch	56 ch	113 ch				
16	21		51	29	54		<b>Red 6</b>		
						000 - 255	0 - 100%		
			52		55		<b>Red 6 Fine</b>		
						000 - 255	Fine adjustment		
17	22		53	30	56		<b>Green 6</b>		
						000 - 255	0 - 100%		
			54		57		<b>Green 6 Fine</b>		
						000 - 255	Fine adjustment		
18	23		55	31	58		<b>Blue 6</b>		
						000 - 255	0 - 100%		
			56		59		<b>Blue 6 Fine</b>		
						000 - 255	Fine adjustment		
			57	32	60		<b>Mint 6</b>		
						000 - 255	0 - 100%		
			58		61		<b>Mint 6 Fine</b>		
						000 - 255	Fine adjustment		
	24		59	33	62		<b>Amber 6</b>		
						000 - 255	0 - 100%		
			60		63		<b>Amber 6 Fine</b>		
						000 - 255	Fine adjustment		
19	25		61	34	64		<b>Red 7</b>		
						000 - 255	0 - 100%		
			62		65		<b>Red 7 Fine</b>		
						000 - 255	Fine adjustment		
20	26		63	35	66		<b>Green 7</b>		
						000 - 255	0 - 100%		
			64		67		<b>Green 7 Fine</b>		
						000 - 255	Fine adjustment		
21	27		65	36	68		<b>Blue 7</b>		
						000 - 255	0 - 100%		
			66		69		<b>Blue 7 Fine</b>		
						000 - 255	Fine adjustment		
			67	37	70		<b>Mint 7</b>		
						000 - 255	0 - 100%		
			68		71		<b>Mint 7 Fine</b>		
						000 - 255	Fine adjustment		
	28		69	38	72		<b>Amber 7</b>		
						000 - 255	0 - 100%		
			70		73		<b>Amber 7 Fine</b>		
						000 - 255	Fine adjustment		

# DMX TRAITS (8 CELL)

MODE/CHANNEL						DMX VALUES	FUNCTION	SNAP	DEF VAL
24 ch A	32 ch B	24 ch B	80 ch	56 ch	113 ch				
22	29		71	39	74	000 - 255	<b>Red 8</b> 0 - 100%		
			72		75	000 - 255	<b>Red 8 Fine</b> Fine adjustment		
23	30		73	40	76	000 - 255	<b>Green 8</b> 0 - 100%		
			74		77	000 - 255	<b>Green 8 Fine</b> Fine adjustment		
24	31		75	41	78	000 - 255	<b>Blue 8</b> 0 - 100%		
			76		79	000 - 255	<b>Blue 8 Fine</b> Fine adjustment		
			77	42	80	000 - 255	<b>Mint 8</b> 0 - 100%		
			78		81	000 - 255	<b>Mint 8 Fine</b> Fine adjustment		
	32		79	43	82	000 - 255	<b>Amber 8</b> 0 - 100%		
			80		83	000 - 255	<b>Amber 8 Fine</b> Fine adjustment		
		1				000 - 255	<b>Hue</b> 0 to 360°		0
		2				000 - 255	<b>Saturation</b> 0 to 100%		0
		3				000 - 255	<b>Dimmer 1</b> Intensity 0 to 100%		0
		4				000 - 255	<b>Hue 2</b> 0 to 360°		0
		5				000 - 255	<b>Saturation 2</b> 0 to 100%		0
		6				000 - 255	<b>Dimmer 2</b> Intensity 0 to 100%		0
		7				000 - 255	<b>Hue 3</b> 0 to 360°		0
		8				000 - 255	<b>Saturation 3</b> 0 to 100%		0
		9				000 - 255	<b>Dimmer 3</b> Intensity 0 to 100%		0

# DMX TRAITS (8 CELL)

MODE/CHANNEL						DMX VALUES	FUNCTION	SNAP	DEF VAL
24 ch A	32 ch B	24 ch B	80 ch	56 ch	113 ch				
		10				000 - 255	<b>Hue 4</b> 0 to 360°		0
		11				000 - 255	<b>Saturation 4</b> 0 to 100%		0
		12				000 - 255	<b>Dimmer 4</b> Intensity 0 to 100%		0
		13				000 - 255	<b>Hue 5</b> 0 to 360°		0
		14				000 - 255	<b>Saturation 5</b> 0 to 100%		0
		15				000 - 255	<b>Dimmer 5</b> Intensity 0 to 100%		0
		16				000 - 255	<b>Hue 6</b> 0 to 360°		0
		17				000 - 255	<b>Saturation 6</b> 0 to 100%		0
		18				000 - 255	<b>Dimmer 6</b> Intensity 0 to 100%		0
		19				000 - 255	<b>Hue 7</b> 0 to 360°		0
		20				000 - 255	<b>Saturation 7</b> 0 to 100%		0
		21				000 - 255	<b>Dimmer 7</b> Intensity 0 to 100%		0
		22				000 - 255	<b>Hue 8</b> 0 to 360°		0
		23				000 - 255	<b>Saturation 8</b> 0 to 100%		0
		24				000 - 255	<b>Dimmer 8</b> Intensity 0 to 100%		0
				44			<b>CCT Presets</b>		
				44		000 - 023	Open	X	0
				44		024 - 085	2400K to 8500K (see Color Temperature Table)		
				44		086 - 255	8500K		
				45			<b>CCT Presets 2</b>		
				45		000 - 023	Open	X	0
				45		024 - 085	2400K to 8500K (see Color Temperature Table)		
				45		086 - 255	8500K		

# DMX TRAITS (8 CELL)

MODE/CHANNEL						DMX VALUES	FUNCTION	SNAP	DEF VAL		
24 ch A	32 ch B	24 ch B	80 ch	56 ch	113 ch						
				46		<b>CCT Presets 3</b>					
						000 - 023	Open	X	0		
						024 - 085	2400K to 8500K (see Color Temperature Table)				
						086 - 255	8500K				
				47		<b>CCT Presets 4</b>					
						000 - 023	Open	X	0		
						024 - 085	2400K to 8500K (see Color Temperature Table)				
						086 - 255	8500K				
				48		<b>CCT Presets 5</b>					
						000 - 023	Open	X	0		
						024 - 085	2400K to 8500K (see Color Temperature Table)				
						086 - 255	8500K				
				49		<b>CCT Presets 6</b>					
						000 - 023	Open	X	0		
						024 - 085	2400K to 8500K (see Color Temperature Table)				
						086 - 255	8500K				
				50		<b>CCT Presets 7</b>					
						000 - 023	Open	X	0		
						024 - 085	2400K to 8500K (see Color Temperature Table)				
						086 - 255	8500K				
				51		<b>CCT Presets 8</b>					
						000 - 023	Open	X	0		
						024 - 085	2400K to 8500K (see Color Temperature Table)				
						086 - 255	8500K				
					84	<b>Variable CCT</b>					
						000 - 023	Open			0	
						024 - 255	2400K to 8500K				
					85	<b>Variable CCT Fine</b>					
						000 - 255	Fine adjustment			0	
					86	<b>Variable CCT 2</b>					
						000 - 023	Open			0	
						024 - 255	2400K to 8500K				
					87	<b>Variable CCT Fine 2</b>					
						000 - 255	Fine adjustment			0	
					88	<b>Variable CCT 3</b>					
						000 - 023	Open			0	
						024 - 255	2400K to 8500K				
					89	<b>Variable CCT Fine 3</b>					
						000 - 255	Fine adjustment			0	

# DMX TRAITS (8 CELL)

MODE/CHANNEL						DMX VALUES	FUNCTION	SNAP	DEF VAL
24 ch A	32 ch B	24 ch B	80 ch	56 ch	113 ch				
					90		<b>Variable CCT 4</b>		0
						000 - 023	Open		
						024 - 255	2400K to 8500K		
					91		<b>Variable CCT Fine 4</b>		0
						000 - 255	Fine adjustment		
					92		<b>Variable CCT 5</b>		0
						000 - 023	Open		
						024 - 255	2400K to 8500K		
					93		<b>Variable CCT Fine 5</b>		0
						000 - 255	Fine adjustment		
					94		<b>Variable CCT 6</b>		0
						000 - 023	Open		
						024 - 255	2400K to 8500K		
					95		<b>Variable CCT Fine 6</b>		0
						000 - 255	Fine adjustment		
					96		<b>Variable CCT 7</b>		0
						000 - 023	Open		
						024 - 255	2400K to 8500K		
					97		<b>Variable CCT Fine 7</b>		0
						000 - 255	Fine adjustment		
					98		<b>Variable CCT 8</b>		0
						000 - 023	Open		
						024 - 255	2400K to 8500K		
					99		<b>Variable CCT Fine 8</b>		0
						000 - 255	Fine adjustment		
					100		<b>Green Shift</b>		0
						000	Idle		
						001 - 127	Full Minus Green to Neutral		
						128	Neutral White		
						129 - 255	Neutral to Full Plus Green		
					101		<b>Green Shift 2</b>		0
						000	Idle		
						001 - 127	Full Minus Green to Neutral		
						128	Neutral White		
						129 - 255	Neutral to Full Plus Green		
					102		<b>Green Shift 3</b>		0
						000	Idle		
						001 - 127	Full Minus Green to Neutral		
						128	Neutral White		
						129 - 255	Neutral to Full Plus Green		

# DMX TRAITS (8 CELL)

MODE/CHANNEL						DMX VALUES	FUNCTION	SNAP	DEF VAL	
24 ch A	32 ch B	24 ch B	80 ch	56 ch	113 ch					
					103		<b>Green Shift 4</b>		0	
						000	Idle			
						001 - 127	Full Minus Green to Neutral			
						128	Neutral White			
						129 - 255	Neutral to Full Plus Green			
					104		<b>Green Shift 5</b>		0	
						000	Idle			
						001 - 127	Full Minus Green to Neutral			
						128	Neutral White			
						129 - 255	Neutral to Full Plus Green			
					105		<b>Green Shift 6</b>		0	
						000	Idle			
						001 - 127	Full Minus Green to Neutral			
						128	Neutral White			
						129 - 255	Neutral to Full Plus Green			
					106		<b>Green Shift 7</b>		0	
						000	Idle			
						001 - 127	Full Minus Green to Neutral			
						128	Neutral White			
						129 - 255	Neutral to Full Plus Green			
					107		<b>Green Shift 8</b>		0	
						000	Idle			
						001 - 127	Full Minus Green to Neutral			
						128	Neutral White			
						129 - 255	Neutral to Full Plus Green			
				52	108		<b>Color</b>		0	
							000	Open		
							001 - 179	Virtual Swatch Book (See Virtual Colors Table)		
								<b>Color Scroll</b>		
							180 - 201	Clockwise, fast to slow		
							202 - 207	Stop		
							228 - 229	Counter-clockwise, slow to fast		
							230 - 234	Open		
								<b>Random Slots</b>		
							235 - 239	Fast		
							240 - 244	Medium		
							245 - 249	Slow		
							250 - 255	Open		
				53	109		<b>Effect Selection</b>		0	
							000 - 255	FX Selection, 1 - 255 (see table)		X

# DMX TRAITS (8 CELL)

MODE/CHANNEL						DMX VALUES	FUNCTION	SNAP	DEF VAL
24 ch A	32 ch B	24 ch B	80 ch	56 ch	113 ch				
				54	110		<b>Effect Speed</b>		
						000 - 126	Fast to slow		
						127 - 128	Stop		
						129 - 255	Slow to fast		0
				55	111		<b>Effect Offset</b>		
						000	Idle		
						001 - 035	Fixture Offset, 10° to 350°		
						036	Synchronized		
						037 - 049	Random Fixture Offset		
						050 - 059	Random Pixel Order		
						060 - 069	Random Steps		
						070 - 079	Idle		
							<b>Effect Fade</b>	X	0
						080 - 089	Sinewave - Cross		
						090 - 099	Sinewave - Full		
						100 - 109	Sawtooth - Cross		
						110 - 119	Sawtooth - Full		
						120 - 129	Ramp Up		
						130 - 139	Ramp Down		
						140 - 149	Steps		
						150 - 255	Idle		
					112		<b>Dim Modes</b>		
						000 - 020	Standard		
						021 - 040	Stage		
						041 - 060	TV		
						061 - 080	Architectural		
						081 - 100	Theatre		
						101 - 120	Stage 2		
							<b>Dimmer Delay Time</b>		
						121	0s	X	0
						122	0.1s		
						123	0.2s		
						124	0.3s		
						125	0.4s		
						126	0.5s		
						127	0.6s		
						128	0.7s		
						129	0.8s		
						130	0.9s		

# DMX TRAITS (8 CELL)

MODE/CHANNEL						DMX VALUES	FUNCTION	SNAP	DEF VAL	
24 ch A	32 ch B	24 ch B	80 ch	56 ch	113 ch					
							<b>Dimmer Delay Time (continued)</b>			
					112	131	1.0s	X	0	
						132	1.5s			
						133	2.0s			
						134	3.0s			
						135	4.0s			
						136	5.0s			
						137	6.0s			
						138	7.0s			
						139	8.0s			
						140	9.0s			
						141	10s			
						142 - 149	Idle			
							<b>Dim to Warm</b>			
						150 - 154	DTW On			
					155 - 159	DTW Off (default)				
					160 - 255	Idle				
						<b>Control</b>				
				56	113	000 - 009	Idle	X	0	
							010 - 014			Fan Mode Auto (default)
							015 - 019			Fan Mode Mute
							020 - 024			Fan Mode Silent
							025 - 029			Fan Mode High
							030 - 049			Idle
							050 - 054			Default Pixel Order
							055 - 059			Flip Pixel Order
							060 - 064			Default Cell Layout
							065 - 069			Split Cell Layout
							070 - 099			Idle
										<b>Refresh Rate (Hz)</b>
							100			900
							101			910
							102			920
							103			930
							104			940
							105			950
					106	960				
					107	970				
					108	980				

# DMX TRAITS (8 CELL)

MODE/CHANNEL						DMX VALUES	FUNCTION	SNAP	DEF VAL
24 ch A	32 ch B	24 ch B	80 ch	56 ch	113 ch				
							<b>Refresh Rate (Hz) (continued)</b>		
						109	990		
						110	1000		
						111	1010		
						112	1020		
						113	1030		
						114	1040		
						115	1050		
						116	1060		
						117	1070		
						118	1080		
						119	1090		
						120	1100		
						121	1110		
						122	1120		
						123	1130		
						124	1140		
						125	1150		
				56	113	126	1160	X	0
						127	1170		
						128	1180		
						129	1190		
						130	1200 (default)		
						131	1210		
						132	1220		
						133	1230		
						134	1240		
						135	1250		
						136	1260		
						137	1270		
						138	1280		
						139	1290		
						140	1300		
						141	1310		
						142	1320		
						143	1330		
						144	1340		
						145	1350		

# DMX TRAITS (8 CELL)

MODE/CHANNEL						DMX VALUES	FUNCTION	SNAP	DEF VAL
24 ch A	32 ch B	24 ch B	80 ch	56 ch	113 ch				
						146	1360		
						147	1370		
						148	1380		
						149	1390		
						150	1400		
						151	1410		
						152	1420		
						153	1430		
						154	1440		
						155	1450		
						156	1460		
						157	1470		
						158	1480		
						159	1490		
						160	1500		
						161	2500		
						162	4000		
						163	5000		
				56	113	164	6000	X	0
						165	10000		
						166	15000		
						167	20000		
						168	25000		
						169 - 174	Idle		
							<b>Color Tuning</b>		
						175 - 176	Highest Fidelity		
						177 - 178	Balanced Output and Fidelity		
						179 - 180	Highest Output (default)		
							<b>Output Balance</b>		
						181 - 182	Bright (Highest Output) (default)		
						183 - 184	Uniform (Elation Full Spectrum Match)		
						185 - 200	Idle		
							<b>Dimmer Curves</b>		
						201 - 210	Linear		
						211 - 220	Square		
						221 - 230	Inverse Square		
						231 - 240	S-Curve (default)		
						241 - 255	Idle		

# DMX TRAITS (16 CELL)

MODE/CHANNEL						DMX VALUES	FUNCTION	SNAP	DEF VAL
48 ch A	64 ch	48 ch B	160 ch	104 ch	217 ch				
				1	1	000 - 255	<b>Dimmer</b> Intensity, 0 - 100%		0
				2	2	000 - 255	<b>Dimmer Fine</b> Fine intensity control		0
				3	3		<b>Shutter/Strobe</b>		50
						000 - 031	Shutter closed		
						032 - 063	No function (shutter open)		
						064 - 095	Strobe effect, slow to fast		
						096 - 127	No function (shutter open)		
						128 - 159	Pulse effect in sequences		
						160 - 191	No function (shutter open)		
						192 - 223	Random strobe effect, slow to fast		
						224 - 225	No function (shutter open)		
						226 - 253	Random pixel, slow to fast		
				254 - 255	No function (shutter open)				
1	1		1	4	4	000 - 255	<b>Red</b> 0 - 100%		
			2		5	000 - 255	<b>Red Fine</b> Fine adjustment		
2	2		3	5	6	000 - 255	<b>Green</b> 0 - 100%		
			4		7	000 - 255	<b>Green Fine</b> Fine adjustment		
3	3		5	6	8	000 - 255	<b>Blue</b> 0 - 100%		
			6		9	000 - 255	<b>Blue Fine</b> Fine adjustment		
			7	7	10	000 - 255	<b>Mint</b> 0 - 100%		
			8		11	000 - 255	<b>Mint Fine</b> Fine adjustment		
	4		9	8	12	000 - 255	<b>Amber</b> 0 - 100%		
			10		13	000 - 255	<b>Amber Fine</b> Fine adjustment		
4	5		11	9	14	000 - 255	<b>Red 2</b> 0 - 100%		
			12		15	000 - 255	<b>Red 2 Fine</b> Fine adjustment		

# DMX TRAITS (16 CELL)

MODE/CHANNEL						DMX VALUES	FUNCTION	SNAP	DEF VAL
48 ch A	64 ch	48 ch B	160 ch	104 ch	217 ch				
5	6		13	10	16		<b>Green 2</b>		
						000 - 255	0 - 100%		
			14		17		<b>Green 2 Fine</b>		
						000 - 255	Fine adjustment		
6	7		15	11	18		<b>Blue 2</b>		
						000 - 255	0 - 100%		
			16		19		<b>Blue 2 Fine</b>		
						000 - 255	Fine adjustment		
			17	12	20		<b>Mint 2</b>		
						000 - 255	0 - 100%		
			18		21		<b>Mint 2 Fine</b>		
						000 - 255	Fine adjustment		
	8		19	13	22		<b>Amber 2</b>		
						000 - 255	0 - 100%		
			20		23		<b>Amber 2 Fine</b>		
						000 - 255	Fine adjustment		
7	9		21	14	24		<b>Red 3</b>		
						000 - 255	0 - 100%		
			22		25		<b>Red 3 Fine</b>		
						000 - 255	Fine adjustment		
8	10		23	15	26		<b>Green 3</b>		
						000 - 255	0 - 100%		
			24		27		<b>Green 3 Fine</b>		
						000 - 255	Fine adjustment		
9	11		25	16	28		<b>Blue 3</b>		
						000 - 255	0 - 100%		
			26		29		<b>Blue 3 Fine</b>		
						000 - 255	Fine adjustment		
			27	17	30		<b>Mint 3</b>		
						000 - 255	0 - 100%		
			28		31		<b>Mint 3 Fine</b>		
						000 - 255	Fine adjustment		
	12		29	18	32		<b>Amber 3</b>		
						000 - 255	0 - 100%		
			30		33		<b>Amber 3 Fine</b>		
						000 - 255	Fine adjustment		
10	13		31	19	34		<b>Red 4</b>		
						000 - 255	0 - 100%		
			32		35		<b>Red 4 Fine</b>		
						000 - 255	Fine adjustment		

# DMX TRAITS (16 CELL)

MODE/CHANNEL						DMX VALUES	FUNCTION	SNAP	DEF VAL
48 ch A	64 ch	48 ch B	160 ch	104 ch	217 ch				
11	14		33	20	36	000 - 255	<b>Green 4</b> 0 - 100%		
			34		37	000 - 255	<b>Green 4 Fine</b> Fine adjustment		
12	15		35	21	38	000 - 255	<b>Blue 4</b> 0 - 100%		
			36		39	000 - 255	<b>Blue 4 Fine</b> Fine adjustment		
			37	22	40	000 - 255	<b>Mint 4</b> 0 - 100%		
			38		41	000 - 255	<b>Mint 4 Fine</b> Fine adjustment		
	16		39	23	42	000 - 255	<b>Amber 4</b> 0 - 100%		
			40		43	000 - 255	<b>Amber 4 Fine</b> Fine adjustment		
13	17		41	24	44	000 - 255	<b>Red 5</b> 0 - 100%		
			42		45	000 - 255	<b>Red 5 Fine</b> Fine adjustment		
14	18		43	25	46	000 - 255	<b>Green 5</b> 0 - 100%		
			44		47	000 - 255	<b>Green 5 Fine</b> Fine adjustment		
15	19		45	26	48	000 - 255	<b>Blue 5</b> 0 - 100%		
			46		49	000 - 255	<b>Blue 5 Fine</b> Fine adjustment		
			47	27	50	000 - 255	<b>Mint 5</b> 0 - 100%		
			48		51	000 - 255	<b>Mint 5 Fine</b> Fine adjustment		
	20		49	28	52	000 - 255	<b>Amber 5</b> 0 - 100%		
			50		53	000 - 255	<b>Amber 5 Fine</b> Fine adjustment		
16	21		51	29	54	000 - 255	<b>Red 6</b> 0 - 100%		
			52		55	000 - 255	<b>Red 6 Fine</b> Fine adjustment		

# DMX TRAITS (16 CELL)

MODE/CHANNEL						DMX VALUES	FUNCTION	SNAP	DEF VAL
48 ch A	64 ch	48 ch B	160 ch	104 ch	217 ch				
17	22		53	30	56	000 - 255	<b>Green 6</b> 0 - 100%		
			54		57	000 - 255	<b>Green 6 Fine</b> Fine adjustment		
18	23		55	31	58	000 - 255	<b>Blue 6</b> 0 - 100%		
			56		59	000 - 255	<b>Blue 6 Fine</b> Fine adjustment		
			57	32	60	000 - 255	<b>Mint 6</b> 0 - 100%		
			58		61	000 - 255	<b>Mint 6 Fine</b> Fine adjustment		
	24		59	33	62	000 - 255	<b>Amber 6</b> 0 - 100%		
			60		63	000 - 255	<b>Amber 6 Fine</b> Fine adjustment		
19	25		61	34	64	000 - 255	<b>Red 7</b> 0 - 100%		
			62		65	000 - 255	<b>Red 7 Fine</b> Fine adjustment		
20	26		63	35	66	000 - 255	<b>Green 7</b> 0 - 100%		
			64		67	000 - 255	<b>Green 7 Fine</b> Fine adjustment		
21	27		65	36	68	000 - 255	<b>Blue 7</b> 0 - 100%		
			66		69	000 - 255	<b>Blue 7 Fine</b> Fine adjustment		
			67	37	70	000 - 255	<b>Mint 7</b> 0 - 100%		
			68		71	000 - 255	<b>Mint 7 Fine</b> Fine adjustment		
	28		69	38	72	000 - 255	<b>Amber 7</b> 0 - 100%		
			70		73	000 - 255	<b>Amber 7 Fine</b> Fine adjustment		
22	29		71	39	74	000 - 255	<b>Red 8</b> 0 - 100%		
			72		75	000 - 255	<b>Red 8 Fine</b> Fine adjustment		

# DMX TRAITS (16 CELL)

MODE/CHANNEL						DMX VALUES	FUNCTION	SNAP	DEF VAL
48 ch A	64 ch	48 ch B	160 ch	104 ch	217 ch				
23	30		73	40	76		<b>Green 8</b>		
						000 - 255	0 - 100%		
			74		77		<b>Green 8 Fine</b>		
						000 - 255	Fine adjustment		
24	31		75	41	78		<b>Blue 8</b>		
						000 - 255	0 - 100%		
			76		79		<b>Blue 8 Fine</b>		
						000 - 255	Fine adjustment		
			77	42	80		<b>Mint 8</b>		
						000 - 255	0 - 100%		
			78		81		<b>Mint 8 Fine</b>		
						000 - 255	Fine adjustment		
	32		79	43	82		<b>Amber 8</b>		
						000 - 255	0 - 100%		
			80		83		<b>Amber 8 Fine</b>		
						000 - 255	Fine adjustment		
25	33		81	44	84		<b>Red 9</b>		
						000 - 255	0 - 100%		
			82		85		<b>Red 9 Fine</b>		
						000 - 255	Fine adjustment		
26	34		83	45	86		<b>Green 9</b>		
						000 - 255	0 - 100%		
			84		87		<b>Green 9 Fine</b>		
						000 - 255	Fine adjustment		
27	35		85	46	88		<b>Blue 9</b>		
						000 - 255	0 - 100%		
			86		89		<b>Blue 9 Fine</b>		
						000 - 255	Fine adjustment		
			87	47	90		<b>Mint 9</b>		
						000 - 255	0 - 100%		
			88		91		<b>Mint 9 Fine</b>		
						000 - 255	Fine adjustment		
	36		89	48	92		<b>Amber 9</b>		
						000 - 255	0 - 100%		
			90		93		<b>Amber 9 Fine</b>		
						000 - 255	Fine adjustment		
28	37		91	49	94		<b>Red 10</b>		
						000 - 255	0 - 100%		
			92		95		<b>Red 10 Fine</b>		
						000 - 255	Fine adjustment		

# DMX TRAITS (16 CELL)

MODE/CHANNEL						DMX VALUES	FUNCTION	SNAP	DEF VAL
48 ch A	64 ch	48 ch B	160 ch	104 ch	217 ch				
29	38		93	50	96		<b>Green 10</b>		
						000 - 255	0 - 100%		
			94		97		<b>Green 10 Fine</b>		
						000 - 255	Fine adjustment		
30	39		95	51	98		<b>Blue 10</b>		
						000 - 255	0 - 100%		
			96		99		<b>Blue 10 Fine</b>		
						000 - 255	Fine adjustment		
			97	52	100		<b>Mint 10</b>		
						000 - 255	0 - 100%		
			98		101		<b>Mint 10 Fine</b>		
						000 - 255	Fine adjustment		
	40		99	53	102		<b>Amber 10</b>		
						000 - 255	0 - 100%		
			100		103		<b>Amber 10 Fine</b>		
						000 - 255	Fine adjustment		
31	41		101	54	104		<b>Red 11</b>		
						000 - 255	0 - 100%		
			102		105		<b>Red 11 Fine</b>		
						000 - 255	Fine adjustment		
32	42		103	55	106		<b>Green 11</b>		
						000 - 255	0 - 100%		
			104		107		<b>Green 11 Fine</b>		
						000 - 255	Fine adjustment		
33	43		105	56	108		<b>Blue 11</b>		
						000 - 255	0 - 100%		
			106		109		<b>Blue 11 Fine</b>		
						000 - 255	Fine adjustment		
			107	57	110		<b>Mint 11</b>		
						000 - 255	0 - 100%		
			108		111		<b>Mint 11 Fine</b>		
						000 - 255	Fine adjustment		
	44		109	58	112		<b>Amber 11</b>		
						000 - 255	0 - 100%		
			110		113		<b>Amber 11 Fine</b>		
						000 - 255	Fine adjustment		
34	45		111	59	114		<b>Red 12</b>		
						000 - 255	0 - 100%		
			112		115		<b>Red 12 Fine</b>		
						000 - 255	Fine adjustment		

# DMX TRAITS (16 CELL)

MODE/CHANNEL						DMX VALUES	FUNCTION	SNAP	DEF VAL
48 ch A	64 ch	48 ch B	160 ch	104 ch	217 ch				
35	46		113	60	116		<b>Green 12</b>		
						000 - 255	0 - 100%		
			114		117		<b>Green 12 Fine</b>		
						000 - 255	Fine adjustment		
36	47		115	61	118		<b>Blue 12</b>		
						000 - 255	0 - 100%		
			116		119		<b>Blue 12 Fine</b>		
						000 - 255	Fine adjustment		
			117	62	120		<b>Mint 12</b>		
						000 - 255	0 - 100%		
			118		121		<b>Mint 12 Fine</b>		
						000 - 255	Fine adjustment		
	48		119	63	122		<b>Amber 12</b>		
						000 - 255	0 - 100%		
			120		123		<b>Amber 12 Fine</b>		
						000 - 255	Fine adjustment		
37	49		121	64	124		<b>Red 13</b>		
						000 - 255	0 - 100%		
			122		125		<b>Red 13 Fine</b>		
						000 - 255	Fine adjustment		
38	50		123	65	126		<b>Green 13</b>		
						000 - 255	0 - 100%		
			124		127		<b>Green 13 Fine</b>		
						000 - 255	Fine adjustment		
39	51		125	66	128		<b>Blue 13</b>		
						000 - 255	0 - 100%		
			126		129		<b>Blue 13 Fine</b>		
						000 - 255	Fine adjustment		
			127	67	130		<b>Mint 13</b>		
						000 - 255	0 - 100%		
			128		131		<b>Mint 13 Fine</b>		
						000 - 255	Fine adjustment		
	52		129	68	132		<b>Amber 13</b>		
						000 - 255	0 - 100%		
			130		133		<b>Amber 13 Fine</b>		
						000 - 255	Fine adjustment		
40	53		131	69	134		<b>Red 14</b>		
						000 - 255	0 - 100%		
			132		135		<b>Red 14 Fine</b>		
						000 - 255	Fine adjustment		

# DMX TRAITS (16 CELL)

MODE/CHANNEL						DMX VALUES	FUNCTION	SNAP	DEF VAL
48 ch A	64 ch	48 ch B	160 ch	104 ch	217 ch				
41	54		133	70	136		<b>Green 14</b>		
						000 - 255	0 - 100%		
			134		137		<b>Green 14 Fine</b>		
						000 - 255	Fine adjustment		
42	55		135	71	138		<b>Blue 14</b>		
						000 - 255	0 - 100%		
			136		139		<b>Blue 14 Fine</b>		
						000 - 255	Fine adjustment		
			137	72	140		<b>Mint 14</b>		
						000 - 255	0 - 100%		
			138		141		<b>Mint 14 Fine</b>		
						000 - 255	Fine adjustment		
	56		139	73	142		<b>Amber 14</b>		
						000 - 255	0 - 100%		
			140		143		<b>Amber 14 Fine</b>		
						000 - 255	Fine adjustment		
43	57		141	74	144		<b>Red 15</b>		
						000 - 255	0 - 100%		
			142		145		<b>Red 15 Fine</b>		
						000 - 255	Fine adjustment		
44	58		143	75	146		<b>Green 15</b>		
						000 - 255	0 - 100%		
			144		147		<b>Green 15 Fine</b>		
						000 - 255	Fine adjustment		
45	59		145	76	148		<b>Blue 15</b>		
						000 - 255	0 - 100%		
			146		149		<b>Blue 15 Fine</b>		
						000 - 255	Fine adjustment		
			147	77	150		<b>Mint 15</b>		
						000 - 255	0 - 100%		
			148		151		<b>Mint 15 Fine</b>		
						000 - 255	Fine adjustment		
	60		149	78	152		<b>Amber 15</b>		
						000 - 255	0 - 100%		
			150		153		<b>Amber 15 Fine</b>		
						000 - 255	Fine adjustment		
46	61		151	79	154		<b>Red 16</b>		
						000 - 255	0 - 100%		
			152		155		<b>Red 16 Fine</b>		
						000 - 255	Fine adjustment		

# DMX TRAITS (16 CELL)

MODE/CHANNEL						DMX VALUES	FUNCTION	SNAP	DEF VAL
48 ch A	64 ch	48 ch B	160 ch	104 ch	217 ch				
47	62		153	80	156		<b>Green 16</b>		
						000 - 255	0 - 100%		
			154		157		<b>Green 16 Fine</b>		
						000 - 255	Fine adjustment		
48	63		155	81	158		<b>Blue 16</b>		
						000 - 255	0 - 100%		
			156		159		<b>Blue 16 Fine</b>		
						000 - 255	Fine adjustment		
			157	82	160		<b>Mint 16</b>		
						000 - 255	0 - 100%		
			158		161		<b>Mint 16 Fine</b>		
						000 - 255	Fine adjustment		
	64		159	83	162		<b>Amber 16</b>		
						000 - 255	0 - 100%		
			160		163		<b>Amber 16 Fine</b>		
						000 - 255	Fine adjustment		
		1					<b>Hue</b>		0
						000 - 255	0 to 360°		
		2					<b>Saturation</b>		0
						000 - 255	0 to 100%		
		3					<b>Dimmer 1</b>		0
						000 - 255	Intensity 0 to 100%		
		4					<b>Hue 2</b>		0
						000 - 255	0 to 360°		
		5					<b>Saturation 2</b>		0
						000 - 255	0 to 100%		
		6					<b>Dimmer 2</b>		0
						000 - 255	Intensity 0 to 100%		
		7					<b>Hue 3</b>		0
						000 - 255	0 to 360°		
		8					<b>Saturation 3</b>		0
						000 - 255	0 to 100%		
		9					<b>Dimmer 3</b>		0
						000 - 255	Intensity 0 to 100%		
		10					<b>Hue 4</b>		0
						000 - 255	0 to 360°		
		11					<b>Saturation 4</b>		0
						000 - 255	0 to 100%		
		12					<b>Dimmer 4</b>		0
						000 - 255	Intensity 0 to 100%		

# DMX TRAITS (16 CELL)

MODE/CHANNEL						DMX VALUES	FUNCTION	SNAP	DEF VAL
48 ch A	64 ch	48 ch B	160 ch	104 ch	217 ch				
		13				000 - 255	<b>Hue 5</b> 0 to 360°		0
		14				000 - 255	<b>Saturation 5</b> 0 to 100%		0
		15				000 - 255	<b>Dimmer 5</b> Intensity 0 to 100%		0
		16				000 - 255	<b>Hue 6</b> 0 to 360°		0
		17				000 - 255	<b>Saturation 6</b> 0 to 100%		0
		18				000 - 255	<b>Dimmer 6</b> Intensity 0 to 100%		0
		19				000 - 255	<b>Hue 7</b> 0 to 360°		0
		20				000 - 255	<b>Saturation 7</b> 0 to 100%		0
		21				000 - 255	<b>Dimmer 7</b> Intensity 0 to 100%		0
		22				000 - 255	<b>Hue 8</b> 0 to 360°		0
		23				000 - 255	<b>Saturation 8</b> 0 to 100%		0
		24				000 - 255	<b>Dimmer 8</b> Intensity 0 to 100%		0
		25				000 - 255	<b>Hue 9</b> 0 to 360°		0
		26				000 - 255	<b>Saturation 9</b> 0 to 100%		0
		27				000 - 255	<b>Dimmer 9</b> Intensity 0 to 100%		0
		28				000 - 255	<b>Hue 10</b> 0 to 360°		0
		29				000 - 255	<b>Saturation 10</b> 0 to 100%		0
		30				000 - 255	<b>Dimmer 10</b> Intensity 0 to 100%		0

# DMX TRAITS (16 CELL)

MODE/CHANNEL						DMX VALUES	FUNCTION	SNAP	DEF VAL
48 ch A	64 ch	48 ch B	160 ch	104 ch	217 ch				
		31				000 - 255	<b>Hue 11</b> 0 to 360°		0
		32				000 - 255	<b>Saturation 11</b> 0 to 100%		0
		33				000 - 255	<b>Dimmer 11</b> Intensity 0 to 100%		0
		34				000 - 255	<b>Hue 12</b> 0 to 360°		0
		35				000 - 255	<b>Saturation 12</b> 0 to 100%		0
		36				000 - 255	<b>Dimmer 12</b> Intensity 0 to 100%		0
		37				000 - 255	<b>Hue 13</b> 0 to 360°		0
		38				000 - 255	<b>Saturation 13</b> 0 to 100%		0
		39				000 - 255	<b>Dimmer 13</b> Intensity 0 to 100%		0
		40				000 - 255	<b>Hue 14</b> 0 to 360°		0
		41				000 - 255	<b>Saturation 14</b> 0 to 100%		0
		42				000 - 255	<b>Dimmer 14</b> Intensity 0 to 100%		0
		43				000 - 255	<b>Hue 15</b> 0 to 360°		0
		44				000 - 255	<b>Saturation 15</b> 0 to 100%		0
		45				000 - 255	<b>Dimmer 15</b> Intensity 0 to 100%		0
		46				000 - 255	<b>Hue 16</b> 0 to 360°		0
		47				000 - 255	<b>Saturation 16</b> 0 to 100%		0
		48				000 - 255	<b>Dimmer 16</b> Intensity 0 to 100%		0
				84		000 - 023	<b>CCT Presets</b> Open	X	0
						024 - 085	2400K to 8500K (see Color Temperature Table)		
						086 - 255	8500K		

# DMX TRAITS (16 CELL)

MODE/CHANNEL						DMX VALUES	FUNCTION	SNAP	DEF VAL
48 ch A	64 ch	48 ch B	160 ch	104 ch	217 ch				
				85		<b>CCT Presets 2</b>	X	0	
					000 - 023	Open			
					024 - 085	2400K to 8500K (see Color Temperature Table)			
					086 - 255	8500K			
				86		<b>CCT Presets 3</b>	X	0	
					000 - 023	Open			
					024 - 085	2400K to 8500K (see Color Temperature Table)			
					086 - 255	8500K			
				87		<b>CCT Presets 4</b>	X	0	
					000 - 023	Open			
					024 - 085	2400K to 8500K (see Color Temperature Table)			
					086 - 255	8500K			
				88		<b>CCT Presets 5</b>	X	0	
					000 - 023	Open			
					024 - 085	2400K to 8500K (see Color Temperature Table)			
					086 - 255	8500K			
				89		<b>CCT Presets 6</b>	X	0	
					000 - 023	Open			
					024 - 085	2400K to 8500K (see Color Temperature Table)			
					086 - 255	8500K			
				90		<b>CCT Presets 7</b>	X	0	
					000 - 023	Open			
					024 - 085	2400K to 8500K (see Color Temperature Table)			
					086 - 255	8500K			
				91		<b>CCT Presets 8</b>	X	0	
					000 - 023	Open			
					024 - 085	2400K to 8500K (see Color Temperature Table)			
					086 - 255	8500K			
				92		<b>CCT Presets 9</b>	X	0	
					000 - 023	Open			
					024 - 085	2400K to 8500K (see Color Temperature Table)			
					086 - 255	8500K			
				93		<b>CCT Presets 10</b>	X	0	
					000 - 023	Open			
					024 - 085	2400K to 8500K (see Color Temperature Table)			
					086 - 255	8500K			
				94		<b>CCT Presets 11</b>	X	0	
					000 - 023	Open			
					024 - 085	2400K to 8500K (see Color Temperature Table)			
					086 - 255	8500K			

# DMX TRAITS (16 CELL)

MODE/CHANNEL						DMX VALUES	FUNCTION	SNAP	DEF VAL
48 ch A	64 ch	48 ch B	160 ch	104 ch	217 ch				
				95		<b>CCT Presets 12</b>		X	0
					000 - 023	Open			
					024 - 085	2400K to 8500K (see Color Temperature Table)			
					086 - 255	8500K			
				96		<b>CCT Presets 13</b>		X	0
					000 - 023	Open			
					024 - 085	2400K to 8500K (see Color Temperature Table)			
					086 - 255	8500K			
				97		<b>CCT Presets 14</b>		X	0
					000 - 023	Open			
					024 - 085	2400K to 8500K (see Color Temperature Table)			
					086 - 255	8500K			
				98		<b>CCT Presets 15</b>		X	0
					000 - 023	Open			
					024 - 085	2400K to 8500K (see Color Temperature Table)			
					086 - 255	8500K			
				99		<b>CCT Presets 16</b>		X	0
					000 - 023	Open			
					024 - 085	2400K to 8500K (see Color Temperature Table)			
					086 - 255	8500K			
				164		<b>Variable CCT</b>			0
					000 - 023	Open			
					024 - 255	2400K - 8500K			
				165		<b>Variable CCT Fine</b>			0
					000 - 255	Fine adjustment			
				166		<b>Variable CCT 2</b>			0
					000 - 023	Open			
					024 - 255	2400K - 8500K			
				167		<b>Variable CCT Fine 2</b>			0
					000 - 255	Fine adjustment			
				168		<b>Variable CCT 3</b>			0
					000 - 023	Open			
					024 - 255	2400K - 8500K			
				169		<b>Variable CCT Fine 3</b>			0
					000 - 255	Fine adjustment			
				170		<b>Variable CCT 4</b>			0
					000 - 023	Open			
					024 - 255	2400K - 8500K			
				171		<b>Variable CCT Fine 4</b>			0
					000 - 255	Fine adjustment			

# DMX TRAITS (16 CELL)

MODE/CHANNEL						DMX VALUES	FUNCTION	SNAP	DEF VAL
48 ch A	64 ch	48 ch B	160 ch	104 ch	217 ch				
					172		<b>Variable CCT 5</b>		
						000 - 023	Open		0
						024 - 255	2400K - 8500K		
					173		<b>Variable CCT Fine 5</b>		
						000 - 255	Fine adjustment		0
					174		<b>Variable CCT 6</b>		
						000 - 023	Open		0
						024 - 255	2400K - 8500K		
					175		<b>Variable CCT Fine 6</b>		
						000 - 255	Fine adjustment		0
					176		<b>Variable CCT 7</b>		
						000 - 023	Open		0
						024 - 255	2400K - 8500K		
					177		<b>Variable CCT Fine 7</b>		
						000 - 255	Fine adjustment		0
					178		<b>Variable CCT 8</b>		
						000 - 023	Open		0
						024 - 255	2400K - 8500K		
					179		<b>Variable CCT Fine 8</b>		
						000 - 255	Fine adjustment		0
					180		<b>Variable CCT 9</b>		
						000 - 023	Open		0
						024 - 255	2400K - 8500K		
					181		<b>Variable CCT Fine 9</b>		
						000 - 255	Fine adjustment		0
					182		<b>Variable CCT 10</b>		
						000 - 023	Open		0
						024 - 255	2400K - 8500K		
					183		<b>Variable CCT Fine 10</b>		
						000 - 255	Fine adjustment		0
					184		<b>Variable CCT 11</b>		
						000 - 023	Open		0
						024 - 255	2400K - 8500K		
					185		<b>Variable CCT Fine 11</b>		
						000 - 255	Fine adjustment		0
					186		<b>Variable CCT 12</b>		
						000 - 023	Open		0
						024 - 255	2400K - 8500K		
					187		<b>Variable CCT Fine 12</b>		
						000 - 255	Fine adjustment		0

# DMX TRAITS (16 CELL)

MODE/CHANNEL						DMX VALUES	FUNCTION	SNAP	DEF VAL
48 ch A	64 ch	48 ch B	160 ch	104 ch	217 ch				
					188		<b>Variable CCT 13</b>		
						000 - 023	Open		0
						024 - 255	2400K - 8500K		
					189		<b>Variable CCT Fine 13</b>		
						000 - 255	Fine adjustment		0
					190		<b>Variable CCT 14</b>		
						000 - 023	Open		0
						024 - 255	2400K - 8500K		
					191		<b>Variable CCT Fine 14</b>		
						000 - 255	Fine adjustment		0
					192		<b>Variable CCT 15</b>		
						000 - 023	Open		0
						024 - 255	2400K - 8500K		
					193		<b>Variable CCT Fine 15</b>		
						000 - 255	Fine adjustment		0
					194		<b>Variable CCT 16</b>		
						000 - 023	Open		0
						024 - 255	2400K - 8500K		
					195		<b>Variable CCT Fine 16</b>		
						000 - 255	Fine adjustment		0
					196		<b>Green Shift</b>		
						000	Idle		
						001 - 127	Full Minus Green to Neutral		0
						128	Neutral White		
						129 - 255	Neutral to Full Plus Green		
					197		<b>Green Shift 2</b>		
						000	Idle		
						001 - 127	Full Minus Green to Neutral		0
						128	Neutral White		
						129 - 255	Neutral to Full Plus Green		
					198		<b>Green Shift 3</b>		
						000	Idle		
						001 - 127	Full Minus Green to Neutral		0
						128	Neutral White		
						129 - 255	Neutral to Full Plus Green		
					199		<b>Green Shift 4</b>		
						000	Idle		
						001 - 127	Full Minus Green to Neutral		0
						128	Neutral White		
						129 - 255	Neutral to Full Plus Green		

# DMX TRAITS (16 CELL)

MODE/CHANNEL						DMX VALUES	FUNCTION	SNAP	DEF VAL
48 ch A	64 ch	48 ch B	160 ch	104 ch	217 ch				
					200		<b>Green Shift 5</b>		0
						000	Idle		
						001 - 127	Full Minus Green to Neutral		
						128	Neutral White		
						129 - 255	Neutral to Full Plus Green		
					201		<b>Green Shift 6</b>		0
						000	Idle		
						001 - 127	Full Minus Green to Neutral		
						128	Neutral White		
						129 - 255	Neutral to Full Plus Green		
					202		<b>Green Shift 7</b>		0
						000	Idle		
						001 - 127	Full Minus Green to Neutral		
						128	Neutral White		
						129 - 255	Neutral to Full Plus Green		
					203		<b>Green Shift 8</b>		0
						000	Idle		
						001 - 127	Full Minus Green to Neutral		
						128	Neutral White		
						129 - 255	Neutral to Full Plus Green		
					204		<b>Green Shift 9</b>		0
						000	Idle		
						001 - 127	Full Minus Green to Neutral		
						128	Neutral White		
						129 - 255	Neutral to Full Plus Green		
					205		<b>Green Shift 10</b>		0
						000	Idle		
						001 - 127	Full Minus Green to Neutral		
						128	Neutral White		
						129 - 255	Neutral to Full Plus Green		
					206		<b>Green Shift 11</b>		0
						000	Idle		
						001 - 127	Full Minus Green to Neutral		
						128	Neutral White		
						129 - 255	Neutral to Full Plus Green		
					207		<b>Green Shift 12</b>		0
						000	Idle		
						001 - 127	Full Minus Green to Neutral		
						128	Neutral White		
						129 - 255	Neutral to Full Plus Green		

# DMX TRAITS (16 CELL)

MODE/CHANNEL						DMX VALUES	FUNCTION	SNAP	DEF VAL	
48 ch A	64 ch	48 ch B	160 ch	104 ch	217 ch					
					208		<b>Green Shift 13</b>		0	
						000	Idle			
						001 - 127	Full Minus Green to Neutral			
						128	Neutral White			
						129 - 255	Neutral to Full Plus Green			
					209		<b>Green Shift 14</b>		0	
						000	Idle			
						001 - 127	Full Minus Green to Neutral			
						128	Neutral White			
						129 - 255	Neutral to Full Plus Green			
					210		<b>Green Shift 15</b>		0	
						000	Idle			
						001 - 127	Full Minus Green to Neutral			
						128	Neutral White			
						129 - 255	Neutral to Full Plus Green			
					211		<b>Green Shift 16</b>		0	
						000	Idle			
						001 - 127	Full Minus Green to Neutral			
						128	Neutral White			
						129 - 255	Neutral to Full Plus Green			
				100	212		<b>Color</b>		0	
							000			Open
							001 - 179			Virtual Swatch Book (See Virtual Colors Table)
										<b>Color Scroll</b>
							180 - 201			Clockwise, fast to slow
							202 - 207			Stop
							228 - 229			Counter-clockwise, slow to fast
							230 - 234			Open
										<b>Random Slots</b>
							235 - 239			Fast
							240 - 244			Medium
							245 - 249			Slow
							250 - 255			Open
				101	213		<b>Effect Selection</b>	X	0	
							000 - 255			FX Selection, 1 - 255 (see table)
				102	214		<b>Effect Speed</b>		0	
							000 - 126			Fast to slow
							127 - 128			Stop
							129 - 255			Slow to fast

# DMX TRAITS (16 CELL)

MODE/CHANNEL						DMX VALUES	FUNCTION	SNAP	DEF VAL	
48 ch A	64 ch	48 ch B	160 ch	104 ch	217 ch					
				103	215		<b>Effect Offset</b>	X	0	
							000			Idle
							001 - 035			Fixture Offset, 10° to 350°
							036			Synchronized
							037 - 049			Random Fixture Offset
							050 - 059			Random Pixel Order
							060 - 069			Random Steps
							070 - 079			Idle
										<b>Effect Fade</b>
							080 - 089			Sinewave - Cross
							090 - 099			Sinewave - Full
							100 - 109			Sawtooth - Cross
							110 - 119			Sawtooth - Full
							120 - 129			Ramp Up
							130 - 139			Ramp Down
							140 - 149			Steps
							150 - 255			Idle
				216		<b>Dim Modes</b>	X	0		
						000 - 020			Standard	
						021 - 040			Stage	
						041 - 060			TV	
						061 - 080			Architectural	
						081 - 100			Theatre	
						101 - 120			Stage 2	
									<b>Dimmer Delay Time</b>	
						121			0s	
						122			0.1s	
						123			0.2s	
						124			0.3s	
						125			0.4s	
						126			0.5s	
						127			0.6s	
						128			0.7s	
						129			0.8s	
					130	0.9s				
					131	1.0s				
					132	1.5s				
					133	2.0s				

# DMX TRAITS (16 CELL)

MODE/CHANNEL						DMX VALUES	FUNCTION	SNAP	DEF VAL	
48 ch A	64 ch	48 ch B	160 ch	104 ch	217 ch					
					216		<b>Dimmer Delay Time (continued)</b>	X	0	
						134	3.0s			
						135	4.0s			
						136	5.0s			
						137	6.0s			
						138	7.0s			
						139	8.0s			
						140	9.0s			
						141	10s			
						142 - 149	Idle			
							<b>Dim to Warm</b>			
						150 - 154	DTW On			
						155 - 159	DTW Off (default)			
						160 - 255	Idle			
				104	217		<b>Control</b>	X	0	
							000 - 009			Idle
							010 - 014			Fan Mode Auto (default)
							015 - 019			Fan Mode Mute
							020 - 024			Fan Mode Silent
							025 - 029			Fan Mode High
							030 - 049			Idle
							050 - 054			Default Pixel Order
							055 - 059			Flip Pixel Order
							060 - 064			Default Cell Layout
							065 - 069			Split Cell Layout
							070 - 099			Idle
										<b>Refresh Rate (Hz)</b>
							100			900
							101			910
							102			920
							103			930
							104			940
							105			950
							106			960
					107	970				
					108	980				
					109	990				
					110	1000				

# DMX TRAITS (16 CELL)

MODE/CHANNEL						DMX VALUES	FUNCTION	SNAP	DEF VAL
48 ch A	64 ch	48 ch B	160 ch	104 ch	217 ch				
							<b>Refresh Rate (Hz) (continued)</b>		
						111	1010		
						112	1020		
						113	1030		
						114	1040		
						115	1050		
						116	1060		
						117	1070		
						118	1080		
						119	1090		
						120	1100		
						121	1110		
						122	1120		
						123	1130		
						124	1140		
						125	1150		
						126	1160		
						127	1170		
				104	217	128	1180	X	0
						129	1190		
						130	1200 (default)		
						131	1210		
						132	1220		
						133	1230		
						134	1240		
						135	1250		
						136	1260		
						137	1270		
						138	1280		
						139	1290		
						140	1300		
						141	1310		
						142	1320		
						143	1330		
						144	1340		
						145	1350		
						146	1360		
						147	1370		

# DMX TRAITS (16 CELL)

MODE/CHANNEL						DMX VALUES	FUNCTION	SNAP	DEF VAL
48 ch A	64 ch	48 ch B	160 ch	104 ch	217 ch				
							<b>Refresh Rate (Hz) (continued)</b>		
						148	1380		
						149	1390		
						150	1400		
						151	1410		
						152	1420		
						153	1430		
						154	1440		
						155	1450		
						156	1460		
						157	1470		
						158	1480		
						159	1490		
						160	1500		
						161	2500		
						162	4000		
						163	5000		
						164	6000		
				104	217	165	10000	X	0
						166	15000		
						167	20000		
						168	25000		
						169 - 174	Idle		
							<b>Color Tuning</b>		
						175 - 176	Highest Fidelity		
						177 - 178	Balanced Output and Fidelity		
						179 - 180	Highest Output (default)		
							<b>Output Balance</b>		
						181 - 182	Bright (Highest Output) (default)		
						183 - 184	Uniform (Elation Full Spectrum Match)		
						185 - 200	Idle		
							<b>Dimmer Curves</b>		
						201 - 210	Linear		
						211 - 220	Square		
						221 - 230	Inverse Square		
						231 - 240	S-Curve (default)		
						241 - 255	Idle		

# CELL ZONES

DEFAULT 1 CELL

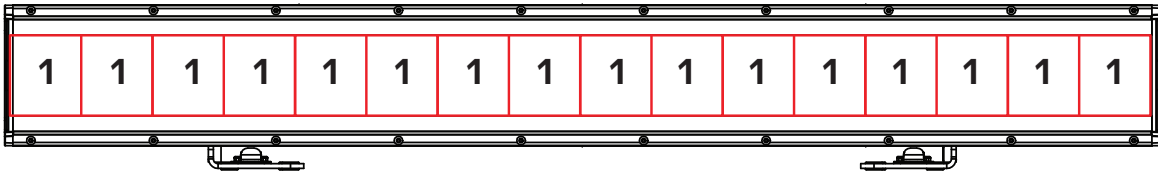

DEFAULT 2 CELL

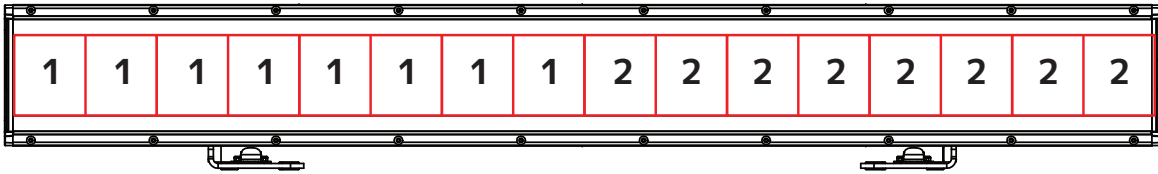

SPLIT 2 CELL

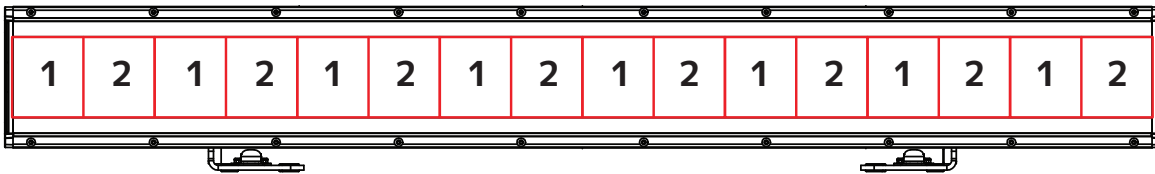

DEFAULT 4 CELL

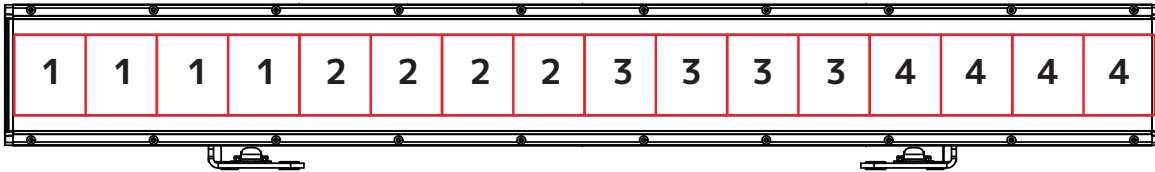

SPLIT 4 CELL

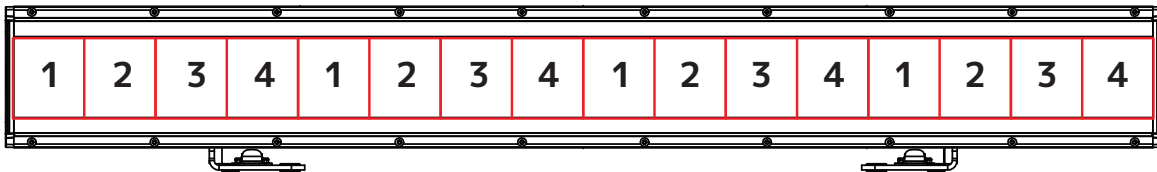

DEFAULT 8 CELL

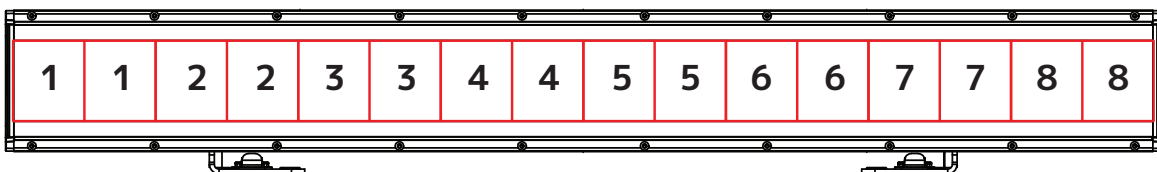

# CELL ZONES

SPLIT 8 CELL

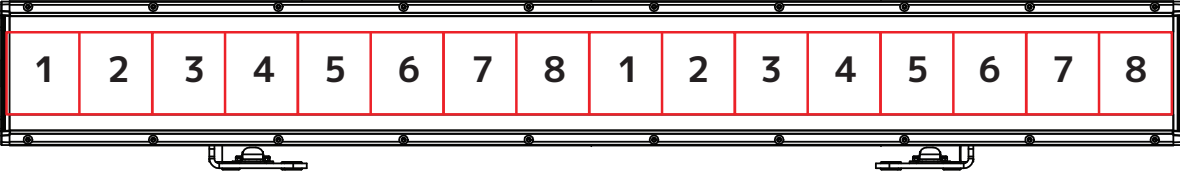

DEFAULT 16 CELL

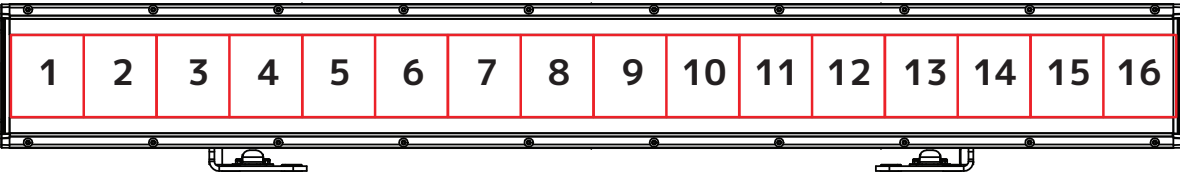

# COLOR TEMPERATURE TABLE

Colors shown are an approximate representation. <https://www.luxalight.eu/en/cie-convector>

DMX VALUE	COLOR TEMPERATURE (K)	DMX VALUE	COLOR TEMPERATURE (K)
24	2400	55	5500
25	2500	56	5600
26	2600	57	5700
27	2700	58	5800
28	2800	59	5900
29	2900	60	6000
30	3000	61	6100
31	3100	62	6200
32	3200	63	6300
33	3300	64	6400
34	3400	65	6500
35	3500	66	6600
36	3600	67	6700
37	3700	68	6800
38	3800	69	6900
39	3900	70	7000
40	4000	71	7100
41	4100	72	7200
42	4200	73	7300
43	4300	74	7400
44	4400	75	7500
45	4500	76	7600
46	4600	77	7700
47	4700	78	7800
48	4800	79	7900
49	4900	80	8000
50	5000	81	8100
51	5100	82	8200
52	5200	83	8300
53	5300	84	8400
54	5400	85	8500

# VIRTUAL COLORS

VALUE	FILTER #	COLOR	VALUE	FILTER #	COLOR
1	7	Pale Yellow	32	49	Medium Purple
2	103	Straw	33	58	Lavender
3	151	Gold Tint	34	199	Palace Blue
4	100	Spring Yellow	35	119	Dark Blue
5	10	Medium Yellow	36	132	Medium Blue
6	101	Yellow	37	120	Deep Blue
7	104	Deep Amber	38	165	Daylight Blue
8	15	Deep Straw	39	161	Slate Blue
9	179	Loving Amber	40	118	Light Blue
10	21	Gold Amber	41	68	Sky Blue
11	105	Orange	42	143	Pale Navy Blue
12	158	Deep Orange	43	131	Marine Blue
13	22	Dark Amber	44	115	Peacock Blue
14	778	Millennium Gold	45	172	Lagoon Blue
15	135	Deep Golden Amber	46	116	Medium Blue Green
16	24	Scarlet	47	90	Dark Yellow Green
17	106	Primary Red	48	139	Primary Green
18	26	Bright Red	49	122	Fern Green
19	27	Medium Red	50	89	Moss Green
20	19	Fire	51	124	Dark Green
21	157	Pink	52	88	Lime Green
22	36	Medium Pink	53	138	Pale Green
23	111	Dark Pink	54	203	Quarter CT Blue
24	128	Bright Pink	55	202	Half CT Blue
25	148	Bright Rose	56	201	Full CT Blue
26	332	Special Rose Pink	57	200	Double CT Blue
27	793	Vanity Fair	58	206	Quarter CT Orange
28	113	Magenta	59	205	Half CT Orange
29	46	Dark Magenta	60	204	Full CT Orange
30	48	Rose Purple	61-179	-	No Function
31	126	Mauve			

# EFFECT SELECTION

<b>DMX VALUES</b>	<b>PROGRAM</b>
001	Program 1
002	Program 2
003	Program 3
004	Program 4
005	Program 5
006	Program 6
007	Program 7
008	Program 8
009	Program 9
010	Program 10
011	Program 11
012	Program 12
013	Program 13
014 - 255	No Function

# DIMMER CURVES

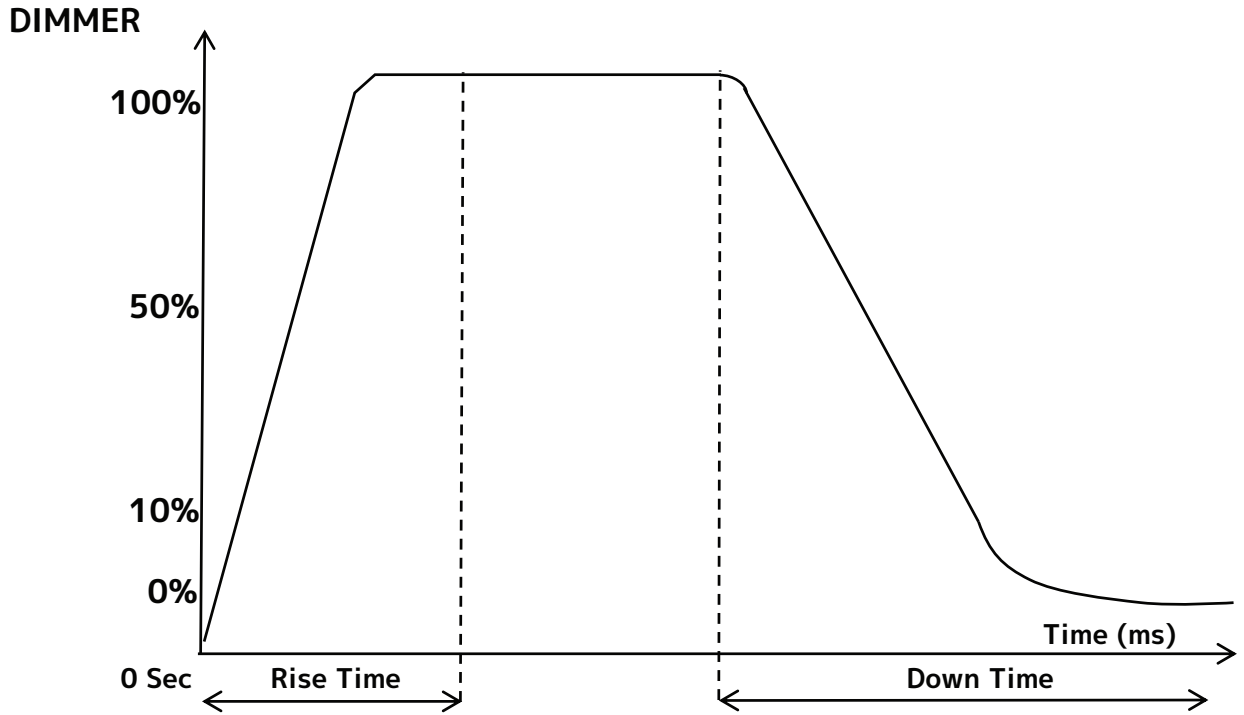

Dimming Curve Ramp Effect	0 sec Fade Time		1 sec Fade Time	
	Rise Time (ms)	Down Time (ms)	Rise Time (ms)	Down Time (ms)
Standard (default)	0	0	0	0
Stage	780	1100	1540	1660
TV	1180	1520	1860	1940
Architectural	1380	1730	2040	2120
Theatre	1580	1940	2230	2280
Stage 2	0	1100	0	1660

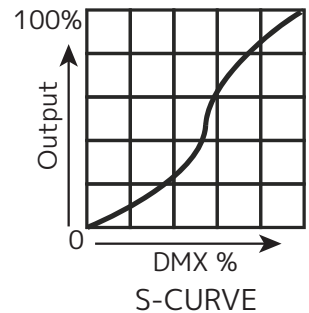
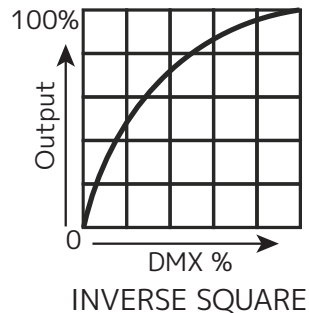
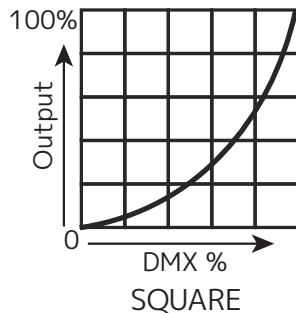
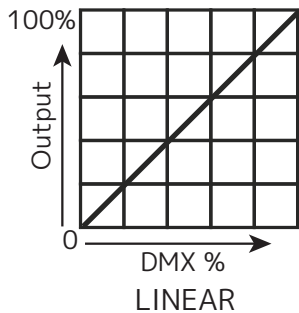

# MAINTENANCE GUIDELINES



**DISCONNECT POWER BEFORE PERFORMING ANY MAINTENANCE!**

## CLEANING

Frequent cleaning is recommended to ensure proper function, optimized light output, and an extended life. The frequency of cleaning depends on the environment in which the fixture operates: damp, smoky or particularly dirty environments can cause greater accumulation of dirt on the fixture's optics. Periodically clean the external lens surface with a soft cloth to avoid dirt/debris accumulation. **NEVER** use alcohol, solvents, or ammonia-based cleaners.

## MAINTENANCE

Regular inspections are recommended to insure proper function and extended life. There are no user serviceable parts inside this fixture. Please refer all other service issues to an authorized Elation service technician. Should you need any spare parts, please order genuine parts from your local Elation dealer.

Please refer to the following points during routine inspections:

- A detailed electric check by an approved electrical engineer every three months, to make sure the circuit contacts are in good condition and prevent overheating.
- Be sure all screws and fasteners are securely tightened at all times. Loose screws may fall out during normal operation, resulting in damage or injury as larger parts could fall.
- Check for any deformations on the housing, color lenses, rigging hardware, and rigging points (ceiling, suspension, trussing). Deformations in the housing could allow for dust to enter into the fixture. Damaged rigging points or unsecured rigging could cause the fixture to fall and seriously injure a person(s).
- Electric power supply cables must not show any damage, material fatigue or sediments.

**NEVER** remove the ground prong from the power cable.

## ERROR CODES

CODE	DESCRIPTION
Base Temp	Base temperature error
LED Temp 1	LED temperature 1 error
LED Temp 2	LED temperature 2 error
LED Temp 3	LED temperature 3 error
LED Temp 4	LED temperature 4 error
Base Fan 1	Base fan 1 error
LED Fan 1	LED fan 1 error
LED Fan 2	LED fan 2 error
LED Fan 3	LED fan 3 error
LED Fan 4	LED fan 4 error
Net error	Network error

# TORQUE SETTINGS FOR SCREWS

IN ORDER TO MAINTAIN THE IP66 RATING ON THE LIGHTING FIXTURES, ALL SCREWS MUST BE TIGHTENED TO THE FOLLOWING TORQUE SPECIFICATION USING A TORQUE DRIVER.

Refer to the table and diagram below for torque specifications.

TORQUE DRIVERS (Recommended): UTICA TS-30 (shown)

ALTERNATE DRIVERS:

- Proto J6107A
- Wiha 28887



**CAUTION! DO NOT OVER TORQUE SCREWS, AS THIS CAN CAUSE LEAKAGE ISSUES!**

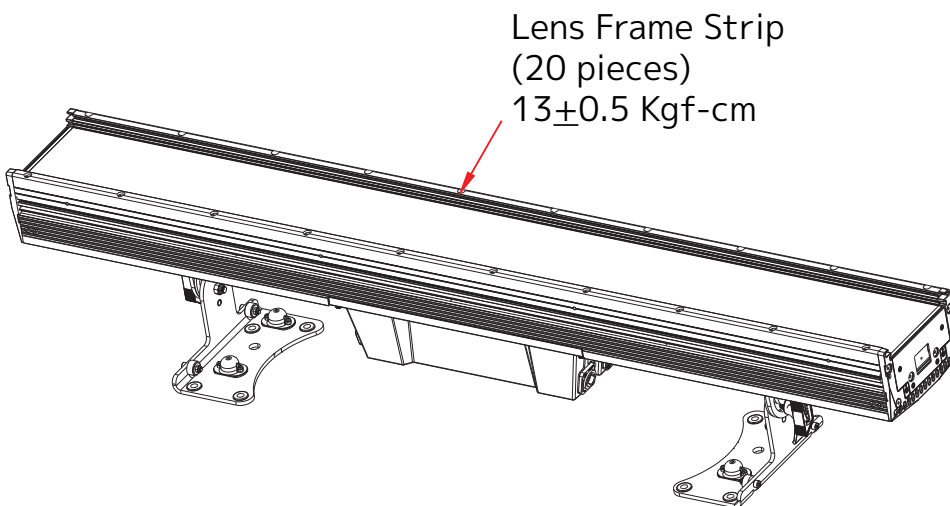
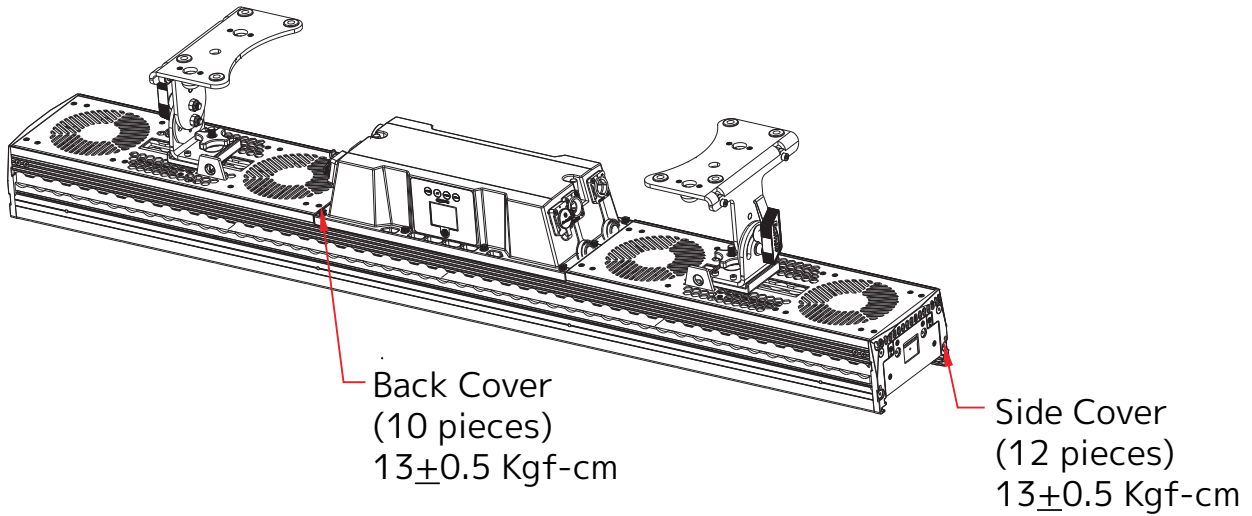

# IP TEST PARAMETERS

Following any repair or maintenance procedure that requires disassembly of the fixture, use Elation’s IP Tester to confirm the IP integrity of the fixture. This fixture features an air valve on the underside of the control panel housing, as shown in the diagram below. Please contact Elation Service for information regarding the Elation IP Tester, or visit the product information page online at: <https://www.elationlighting.com/ip-tester>

**Air Valve**

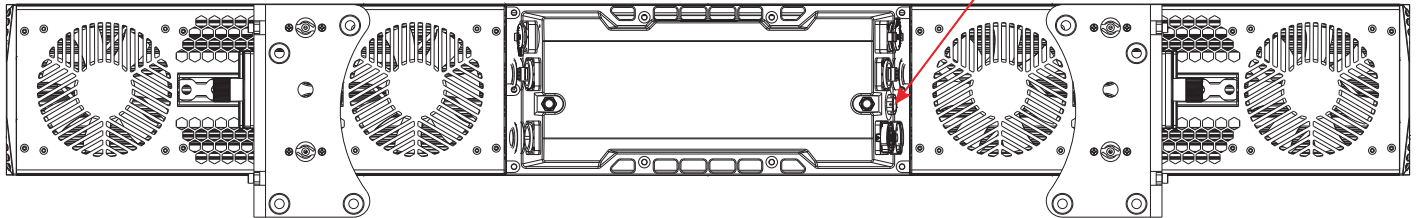

**CAUTION! THE USE OF PROTECTIVE GLOVES AND SAFETY GOGGLES IS STRONGLY RECOMMENDED WHILE PERFORMING THE IP PRESSURE TEST! AVOID PLACING YOUR FACE, EYES, HANDS, ETC IN PROXIMITY TO THE LENS OF THE FIXTURE WHILE PERFORMING THE TEST!**

**DE-HUMIDIFICATION:** IP66 fixtures operating in high-humidity environments may experience residual fogging or condensation. Such fogging will not affect the fixture, and can be removed using the following procedure: position the unit with the air valve pointing upwards, then open the air valves and run the unit for 1-2 hours after reaching operating temperature. Then, while the fixture is still hot, re-install the air valve and allow the unit to cool down. Please note: this procedure should be performed in a dry, climate-controlled environment. Avoid additional fogging by drying the fixture completely before placing into a road case.



IP PRESSURE TESTING PARAMETERS					
Minimum Pressure	Maximum Pressure	Inflation Time	Stabilization Time	Detection Time	Acceptable Leakage
20 kPa	23 kPa	30 s	15 s	15 s	100 Pa

# SOFTWARE UPDATES



**ONLY QUALIFIED TECHNICIANS SHOULD PERFORM THIS FUNCTION!**  
**NOTE ALL MENU SETTINGS BEFORE UPDATING SOFTWARE!**  
**FIXTURE SOFTWARE CAN NOT BE DOWNGRADED!**  
**DOWNLOAD FIXTURE SOFTWARE TO PC ONLY! (NO MAC SUPPORT)**  
**PLEASE CONTACT ELATION SERVICE FOR FURTHER INFORMATION.**

Updates can be performed over the **Aria** connection, or with an **Elation C-Loader** device. Please contact Elation service for details or to order the C-Loader device.

**ELATION SERVICE USA** - Monday - Friday 8:00am to 4:30pm PST  
323-582-3322 | [support@elationlighting.com](mailto:support@elationlighting.com)

**ELATION SERVICE EUROPE** - Monday - Friday 08:30 to 17:00 CET  
+31 45 546 85 63 | [support@elationlighting.eu](mailto:support@elationlighting.eu)

## ORDERING INFORMATION

SKU (US)	SKU (EU)	DESCRIPTION
KLB248	Pending	Elation KL Batten 48
OB-107-90B	Pending	90-degree Slotted Omega Bracket
LTR001	1744000021	L-Track to M10 Adapter, 70mm
LTR008	Pending	L-Track to M10 Adapter, 44.5mm
LTR100	Pending	L-Track C-Clamp & Adapter Assembly, 70mm
LTR112	Pending	L-Track C-Clamp & Adapter Assembly, 44.5mm

# SPECIFICATIONS

## SOURCE

(16) x 100W RGBMA LEDs

30,000 Hour Average LED Life\*

\*May vary depending on several factors including but not limited to: Environmental Conditions, Power/Voltage, Usage Patterns (On-Off Cycling), Control and Dimming.

## PHOTOMETRIC DATA

39.475 (Integrating Sphere)

CRI- 94.9

TLCI- 95

Beam Angle: 62° x 21°

Field Angle: 79° x 51°

## EFFECTS

Full Pixel Control

Electronic Dimmer and Strobe

Variable 16-bit Dimming Modes and Curves

## COLOR

RGBMA Color Array

CMY Emulation

16bit Fully Variable CCT 2400K - 8500K

Green/Magenta Shift

Dim-to-Warm Fade

Virtual Gel Swatch Book

## CONTROL / CONNECTIONS

34 DMX Channel Modes (1ch, 3ch-A, 4ch-A, 4ch-B, 3ch-B, 6ch-A, 10ch, 14ch, 22ch, 16ch-A, 6ch-B, 8ch, 6ch-C, 20ch-A, 20ch-B, 35ch, 12ch-A, 16ch-B, 12ch-B, 40ch, 32ch-A, 61ch, 24ch-A, 32ch-B, 24ch-B, 80ch, 56ch, 113ch, 48ch-A, 64ch, 48ch-B, 160ch, 104ch, 217ch)

4 Button Control Panel, Color LED Display

RDM (Remote Device Management)

Aria x2 Wireless Device Management

NFC Configuration

IP65 5pin XLR DMX In/Out

IP65 RJ45 Ethernet In/Out (Art-Net & sACN)

IP65 Locking Power Cable In/Out

## SIZE / WEIGHT

Length: 47.7" (1211mm)

Width: 7.2" (184mm)

Vertical Height: 9.4" (239mm)

Vertical Height (Low Clearance): 8.6" (219mm)

Weight: 43.2 lbs / 19.6kg

## ELECTRICAL / THERMAL

AC 100-240V - 50/60Hz

800W Max Power Consumption

Power Thru Capacity: 4A ( 0 units @110V; 1 unit @240V)

-40°F to 131°F (-40°C to 55°C)

BTU/hr (+/- 10%) 2,728

## INCLUDED ITEMS

Glare Shield

Border Light Filter

2x Safety Cable

IP65 Locking Power Cable

## OPTIONAL ITEMS

Omega Bracket (Qty 2)

L-Track to M10 Adapter, 70mm (LTR001)

L-Track to M10 Adapter, 44.5mm (LTR008)

L Track C-Clamp & Adapter Assembly, 70mm (LTR100)

L Track C-Clamp & Adapter Assembly, 44.5mm (LTR112)

## APPROVALS / RATINGS

CE | cETLus | IP65 | FCC | UKCA



Specifications and documentation subject to change without notice.

# DIMENSIONAL DRAWINGS

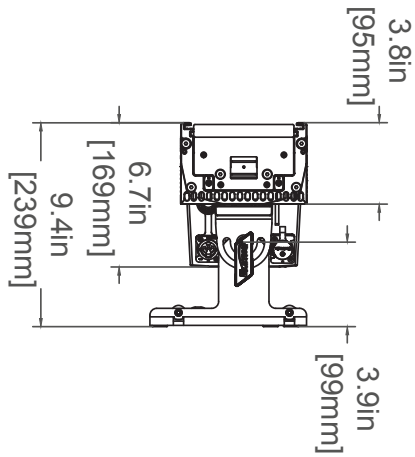
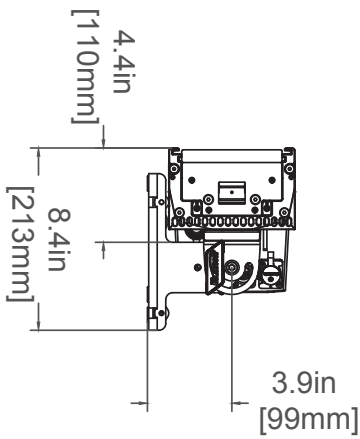
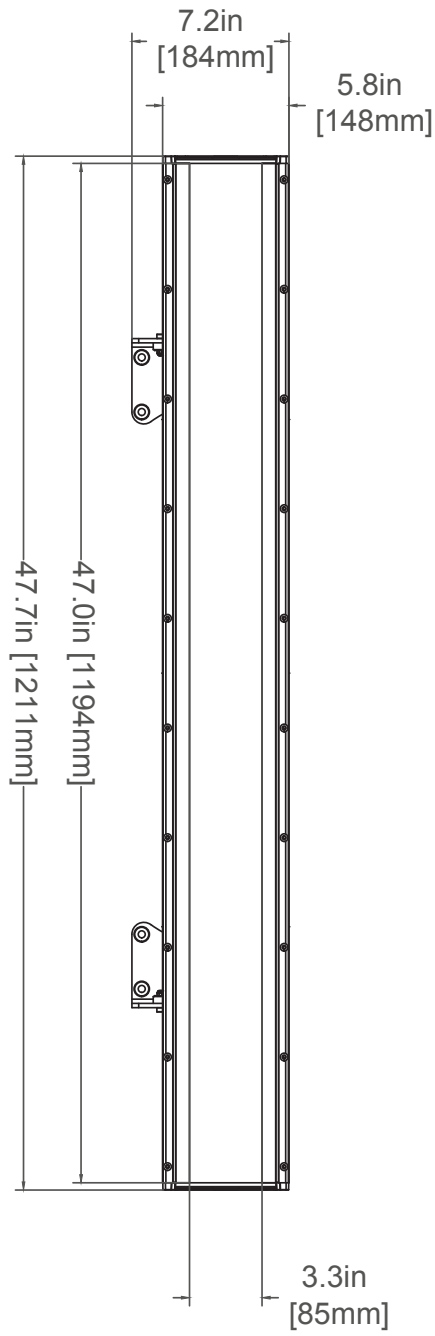
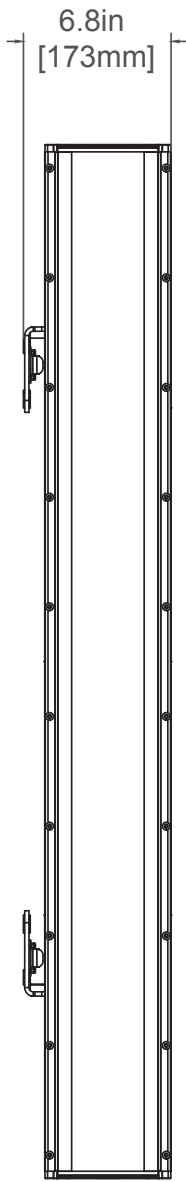

## LOW CLEARANCE CONFIGURATION

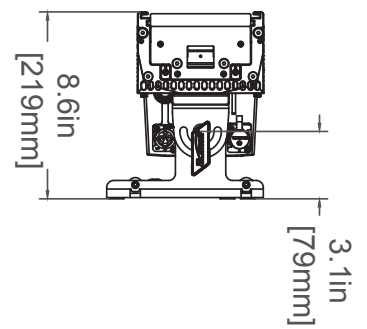

## **FCC STATEMENT**

This device complies with Part 15 of the FCC Rules. Operation is subject to the following two conditions: (1) this device may not cause harmful interference, and (2) this device must accept any interference received, including interference that may cause undesired operation.

### **FCC RADIO FREQUENCY INTERFERENCE WARNINGS & INSTRUCTIONS**

This product has been tested and found to comply with the limits as per Part 15 of the FCC Rules. These limits are designed to provide reasonable protection against harmful interference in a residential installation. This device uses and can radiate radio frequency energy and, if not installed and used in accordance with the included instructions, may cause harmful interference to radio communications. However, there is no guarantee that interference will not occur in a particular installation. If this device does cause harmful interference to radio or television reception, which can be determined by turning the device off and on, the user is encouraged to try to correct the interference by one or more of the following methods:

- Reorient or relocate the device.
- increase the separation between the device and the receiver.
- Connect the device to an electrical outlet on a circuit different from which the radio receiver is connected.
- Consult the dealer or an experienced radio/TV technician for help.

Energy Saving Matters (EuP 2009/125/EC)

Saving electric energy is a key to help protecting the environment. Please turn off all electrical products when they are not in use. To avoid power consumption in idle mode, disconnect all electrical equipment from power when not in use. Thank you!



