

ELIMINATOR[®]

LIGHTING

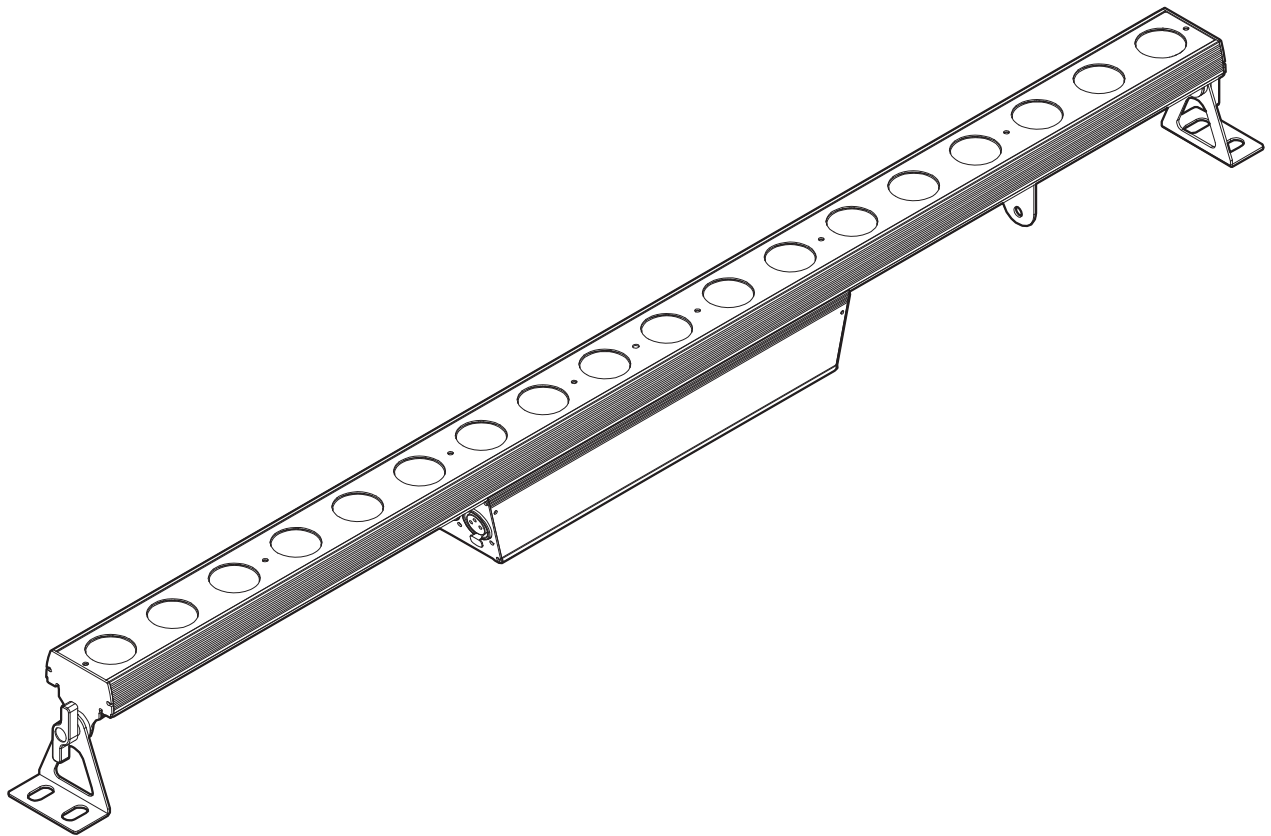

MEGA COLOR Q18

User Manual

©2026 **Eliminator Lighting** all rights reserved. Information, specifications, diagrams, images, and instructions herein are subject to change without notice. Eliminator logo and identifying product names and numbers herein are trademarks of Eliminator Lighting. Copyright protection claimed includes all forms and matters of copyrightable materials and information now allowed by statutory or judicial law or hereinafter granted. Product names used in this document may be trademarks or registered trademarks of their respective companies and are hereby acknowledged. All non-Eliminator brands and product names are trademarks or registered trademarks of their respective companies.

Eliminator Lighting and all affiliated companies hereby disclaim any and all liabilities for property, equipment, building, and electrical damages, injuries to any persons, and direct or indirect economic loss associated with the use or reliance of any information contained within this document, and/or as a result of the improper, unsafe, insufficient and negligent assembly, installation, rigging, and operation of this product.

Eliminator Lighting

6122 S. Eastern Ave. Los Angeles, CA. 90040
323-582-2650 | www.adj.com | info@adj.com

ADJ SUPPLY Europe B.V

Junostraat 2 6468 EW Kerkrade, The Netherlands
+31 (0)45 546 85 00 | www.adj.eu | info@adj.eu

ADJ PRODUCTS GROUP Mexico

AV Santa Ana 30 Parque Industrial Lerma, Lerma, Mexico 52000
+52 (728) 282-7070

DOCUMENT VERSION



Due to additional product features and/or enhancements, an updated version of this document may be available online. Please check www.adj.com for the latest revision/update of this manual before beginning installation and/or programming.

Date	Document Version	Software Version >	DMX Channel Mode	Notes
04/07/26	1.0	1.00	4 / 6 / 9 / 72 / 74 Ch	Initial Release

CONTENTS

Introduction	4
Features Safety Guidelines	5
Overview	6
Installation	7
Control Panel	11
System Menu	12
DMX Setup	13
DMX Traits	16
Primary-Secondary Mode Multi Unit Power Linking	22
Fuse Replacement Cleaning	23
Specifications	24
Dimensional Drawings	25

INTRODUCTION

UNPACKING

Thank you for purchasing the Mega Color Q18 by Eliminator Lighting. Every unit has been thoroughly tested and has been shipped in perfect operating condition. Carefully check the shipping carton for damage that may have occurred during shipping. If the carton appears to be damaged, carefully inspect your fixture for any damage and be sure all accessories necessary to operate the unit have arrived intact. In the event that damage has been found or parts are missing, please contact our toll free customer support number for further instructions. Do not return this unit to your dealer without first contacting customer support.

INTRODUCTION

The Eliminator Lighting Mega Color Q18 delivers vibrant color mixing and dynamic effects for stage, DJ, and venue lighting. Featuring 18 RGBA LED's, multiple DMX channel modes, built-in programs, and sound-active operation, this versatile bar provides smooth color transitions, strobing, and powerful washes in a compact, lightweight design. To optimize the performance of this product, please read these operating instructions carefully to familiarize yourself with the basic operations of this unit. These instructions contain important safety information regarding the use and maintenance of this unit. Please keep this manual with the unit for future reference.

ADJ SERVICE USA - Monday - Friday 8:00am to 4:30pm PST

Voice: 800-322-6337 | support@adj.com

LIMITED WARRANTY

For up-to-date warranty information regarding your device, please visit ADJ's warranty information page online or scan the QR codes below.



USA: <https://www.adj.com/warranty-information>



EU: https://www.adj.eu/terms_and_conditions

Warning! To prevent or reduce the risk of electrical shock or fire, do not expose this unit to rain or moisture.

Caution! There are no user serviceable parts inside this unit. Do not attempt any repairs yourself, as doing so will void your manufacturer's warranty. In the event that your unit requires service, please contact Eliminator Lighting for assistance.

PLEASE recycle the shipping carton when ever possible.

FEATURES

- 18 x 4W RGBA (4-in-1) LEDs
- 25° Beam Angle
- DMX512, Auto Mode, Primary-Secondary Mode, and Sound Active Mode
- Five DMX Channel Configurations
- Built In Programs, Color Selection Modes, Color Changing, and Strobe Effects
- Standard 3-pin XLR Connectors
- IP20 Rating

SAFETY GUIDELINES

- To reduce the risk of electrical shock or fire, do not expose this unit to rain or moisture.
- Do not spill water or other liquids into or on to your unit.
- Do not attempt to operate this unit if the power cord has been frayed or broken.
- Do not attempt to remove or break off the ground prong from the electrical cord. This prong is used to reduce the risk of electrical shock and fire in case of an internal short.
- Disconnect from main power before making any type of connection.
- Do not remove the cover for any reason. There are no user serviceable parts inside.
- Never operate this unit with the cover removed.
- Never plug this unit in to a dimmer pack.
- Always be sure to mount this unit in an area that will allow proper ventilation. Allow about 6” (15cm) between this device and a wall.
- Do not attempt to operate this unit if it has been damaged in any way.
- This unit is intended for indoor use only, and use of this product outdoors voids all warranties.
- During long periods of non-use, disconnect the unit from main power.
- Always mount this unit in safe and stable matter.
- Power-supply cords should be routed so that they are not likely to be walked on or pinched by items placed upon or against them, paying particular attention to the point at which they exit from the unit.
- Cleaning - The fixture should be cleaned only as recommended by the manufacturer. See the **Cleaning** section of this manual for details.
- Heat - The appliance should be situated away from heat sources such as radiators, heat registers, stoves, or other appliances (including amplifiers) that produce heat.
- The fixture should be serviced by qualified service personnel when:
 - A. The power-supply cord or the plug has been damaged.
 - B. Objects have fallen onto, or liquid has been spilled into, the appliance.
 - C. The appliance has been exposed to rain or water.
 - D. The appliance does not appear to operate normally or exhibits a marked change in performance.

OVERVIEW

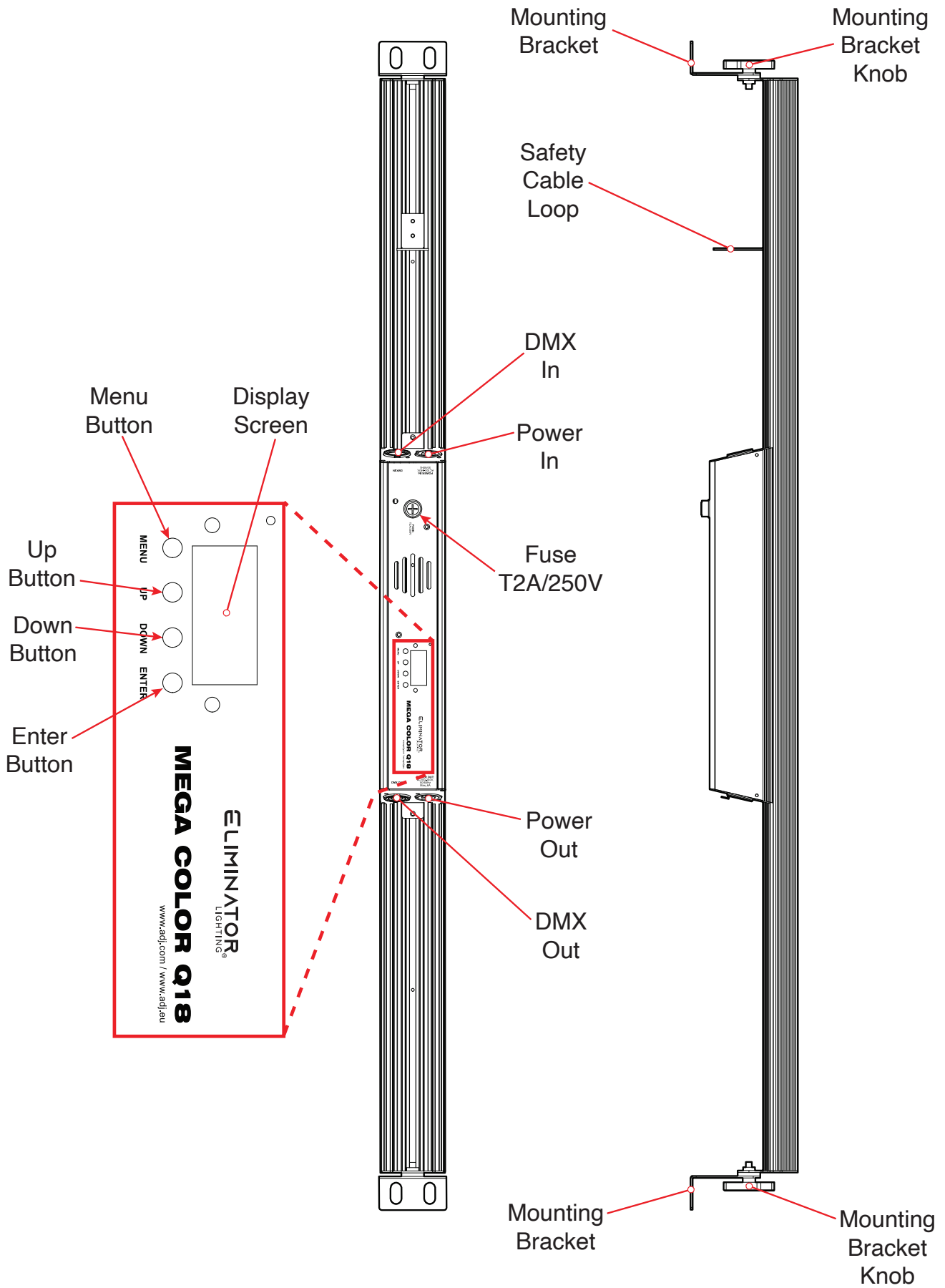

INSTALLATION



MINIMUM SAFE DISTANCE TO OTHER OBJECTS IS 1.0 FEET (0.3 METER)
MINIMUM SAFE DISTANCE TO FLAMMABLE MATERIALS IS 3.3 FEET (1 METER)
MINIMUM DISTANCE TO ILLUMINATED OBJECTS IS 1.6 FEET (0.5 METER)



DO NOT INSTALL THE FIXTURE IF YOU ARE NOT QUALIFIED TO DO SO!

Fixture **MUST** be installed following all local, national, and country commercial electrical and construction codes and regulations.

When installing the unit, the trussing or area of installation must be able to hold 10 times the weight of the unit and any attached accessories without any deformation. The unit must be secured with a secondary safety attachment, e.g. an appropriately-rated safety cable.

Before rigging/mounting a single fixture to any metal truss/structure or placing the fixture(s) on any surface, a professional equipment installer **MUST** be consulted to determine if the metal truss/structure or surface is properly certified to safely hold the combined weight of the fixture(s), clamps, cables, and accessories.

Maximum ambient operating temperature is ***-4°F to 113°F (-20°C to 45°C)***.

Fixture(s) should be installed away from walking paths, seating areas, or areas where unauthorized personnel might reach the fixture by hand.

NEVER stand directly below the fixture(s) when rigging, removing, or servicing.

Overhead fixture installation must always be secured with a secondary safety attachment, such as an appropriately rated safety cable that can hold 10 times the weight of the fixture.

Overhead mounting requires extensive experience, including calculating working load limits, knowledge of installation material being used, and periodic safety inspection of all installation material as well as the unit itself. If you lack these qualifications, do not attempt the installation yourself.

The installation should be checked by a skilled person once a year.

INSTALLATION

CLAMP MOUNTING

This fixture features a hole on top of each mounting bracket for the fitment of a clamp. To truss mount this unit, align the hole in the bottom of the clamp with the hole on the fixture's bracket, then insert a nut of the appropriate size through both the clamp and the bracket and secure in place with a matching nut. **Please note that two mounting clamps are required to securely mount this fixture.** Attach a safety cable of the appropriate rating to the provided loop located on the rear of the fixture, between the DMX/Power In ports and the mounting bracket.

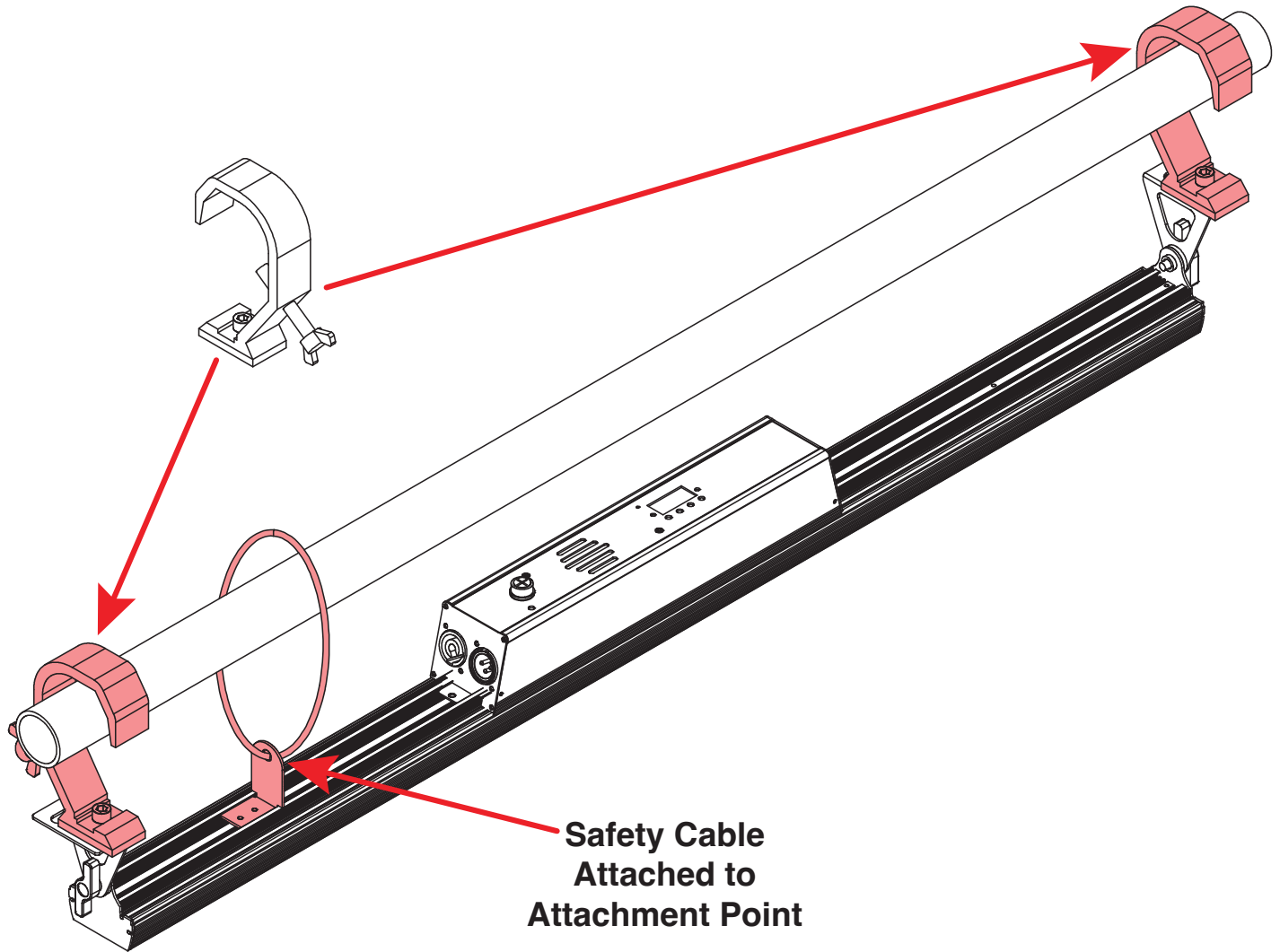

**SAFETY CABLE:
ALWAYS ATTACH A SAFETY CABLE WHENEVER INSTALLING THIS
FIXTURE IN A SUSPENDED ENVIRONMENT TO ENSURE THAT THE FIXTURE
WILL NOT FALL IF THE CLAMP FAILS.**

INSTALLATION

The unit is fully operational in three different mounting positions: hanging upside-down from the ceiling or trussing, or sideways on trussing. Be sure this fixture is kept at least 1m (3.3 ft) away from any flammable materials (decorations, etc). Always use and install a safety cable (not included) as a safety measure to prevent accidental damage and/or injury in the event the clamp fails.

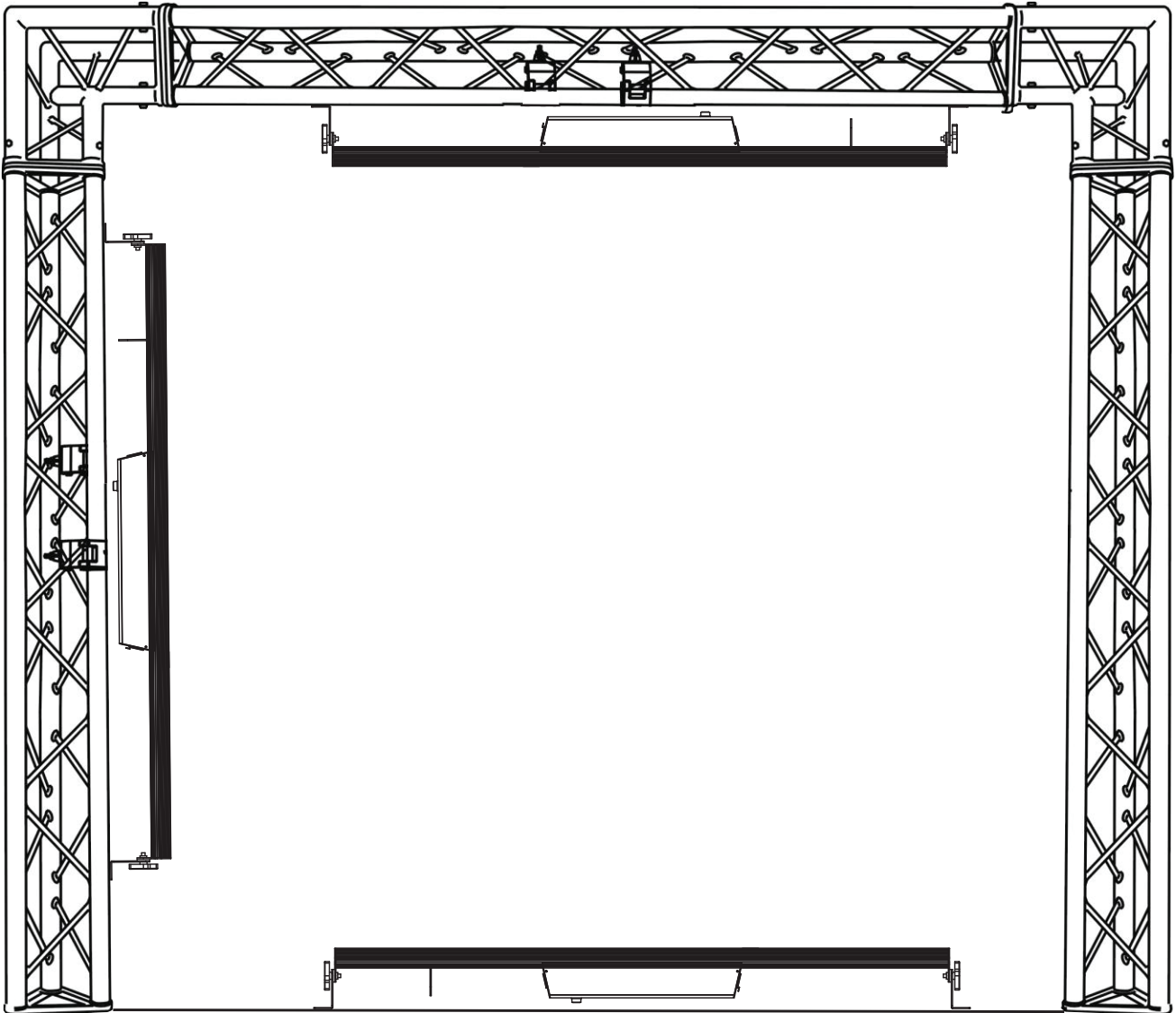

FALLING FIXTURES CAN CAUSE SEVERE INJURY OR SERIOUS EQUIPMENT DAMAGE! FOR THIS REASON, FIXTURES SHOULD BE INSTALLED AND INSPECTED ONLY BY QUALIFIED PERSONNEL. DO NOT INSTALL THE UNIT IF YOU LACK THE QUALIFICATIONS TO DO SO, OR IF YOU HAVE DOUBTS ABOUT THE SAFETY AND SECURITY OF THE INSTALLATION SETUP OR LOCATION!



ALWAYS ATTACH A SAFETY CABLE WHENEVER INSTALLING THIS FIXTURE IN A SUSPENDED ENVIRONMENT TO ENSURE THAT THE FIXTURE WILL NOT FALL IF THE CLAMP FAILS.

INSTALLATION

POTENTIAL INTERNAL FIXTURE DAMAGE FROM EXTERNAL SOURCES OF LIGHT BEAMS

External sources of light beams from direct sunlight, lighting and moving head fixtures, and lasers, which are focused directly towards the exterior housing and/or penetrate the front lens opening of Eliminator lighting fixtures, can cause severe internal damage including burning of optics, dichroic color filters, glass and metal gobos, prisms, animation wheels, frost filters, iris, shutters, motors, belts, wiring, discharge lamps, and LEDs.

This issue is not specific only to Eliminator lighting fixtures, but rather it is a common issue with lighting fixtures from all manufacturers. Although there is no true way to fully prevent this issue from happening, the guidelines below can reduce the risk of potential damage. Contact Eliminator Service for more details.

DO NOT EXPOSE THE FIXTURE AND/OR FRONT LENS OPENING TO LIGHT BEAMS FROM DIRECT SUNLIGHT, OTHER LIGHTING OR MOVING HEAD FIXTURES, AND LASERS DURING UNPACKING, INSTALLATION, USE, AND EXTENDED IDLE TIMES OUTDOORS. DO NOT FOCUS A LIGHT BEAM FROM ONE LIGHTING FIXTURE DIRECTLY TOWARDS ANOTHER.

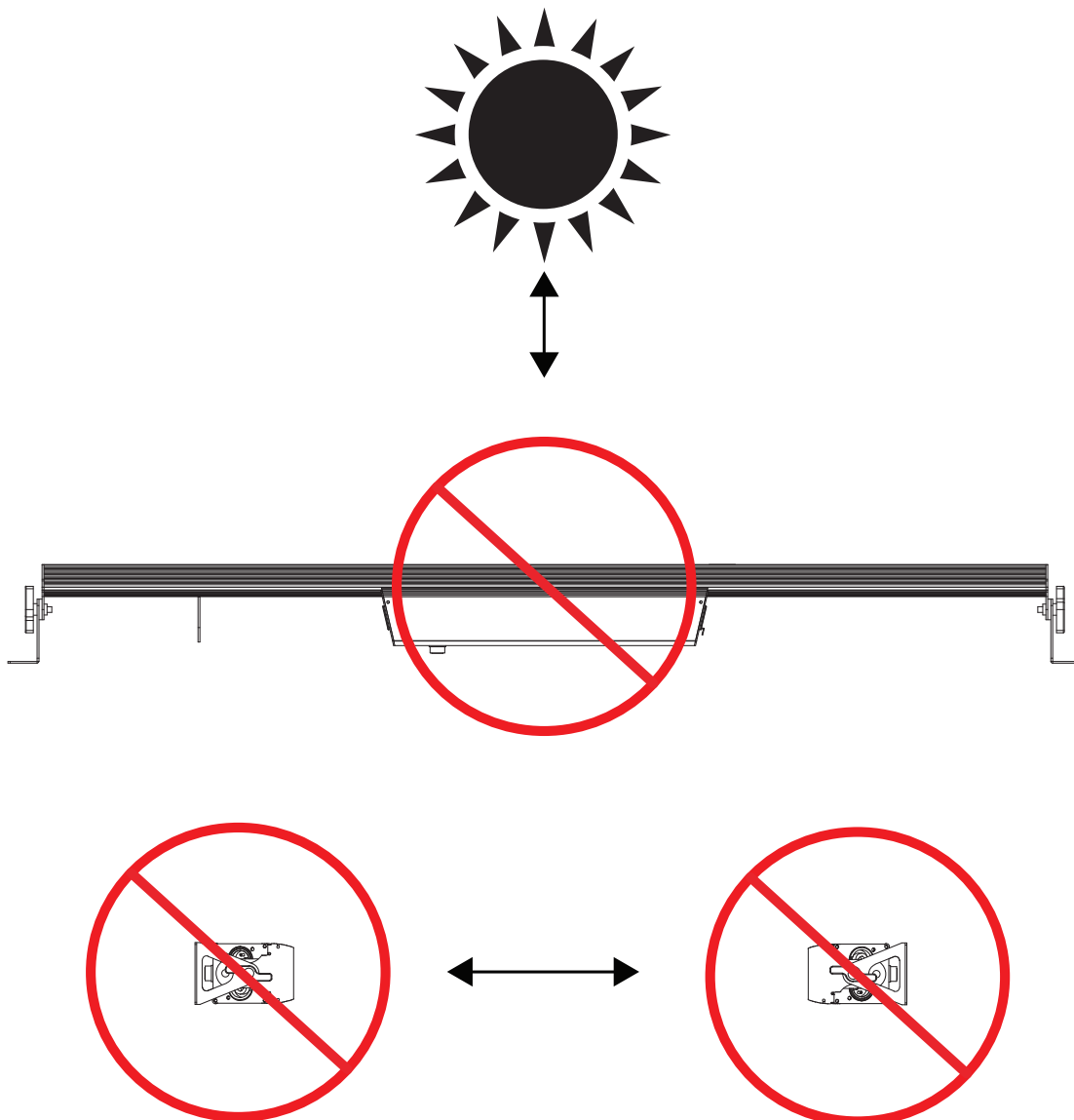

CONTROL PANEL

This fixture features a display screen with a 4-button control pad, which can be used to easily adjust any device settings.

Pressing the MENU button will cycle through the various Main Menu options. When the desired Main Menu option is displayed on the screen, press the ENTER button to enter the sub-menu, then use the UP and DOWN buttons to scroll through sub-menu options. In some cases, there will be a second sub-menu that can be navigated in the same way.

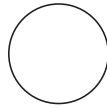
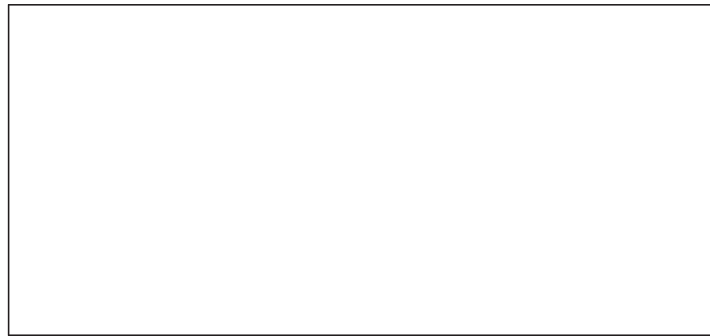

MENU

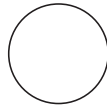

UP

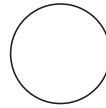

DOWN

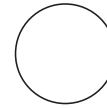

ENTER

SYSTEM MENU

MAIN MENU	OPTIONS / VALUES		DESCRIPTION
Axxx	001 - 512		DMX address
Chnd	4 Channel		DMX channel mode
	6 Channel		
	9 Channel		
	72 Channel		
	74 Channel		
Rxxx	000 - 255		All Red Dimmer, 0-100%
Gxxx	000 - 255		All Green Dimmer, 0-100%
Bxxx	000 - 255		All Blue Dimmer, 0-100%
Axxx	000 - 255		All Amber Dimmer, 0-100%
Fxxx	000 - 255		Strobe/Shutter
dxxx	000 - 255		Master Dimmer
CLxx	01		Red
	02		Green
	03		Blue
	04		Amber
	05		Yellow
	06		Purple
	07		Cyan
	08		RGBA
EFxx	01 - 20	SP01 - SP15	Press UP to switch the effect (EF01 - EF20), then press ENTER to set the speed (SP01 - SP15)
SUxx	01 - 06	SE01 - SE15	Switch the sound mode (SU01 - SU06), then press ENTER to set the sensitivity (SE01 - SE15)

DMX SETUP

DMX-512: DMX is short for Digital Multiplex. This is a universal protocol used as a form of communication between intelligent fixtures and controllers. A DMX controller sends DMX data instructions from the controller to the fixture. DMX data is sent as serial data that travels from fixture to fixture via the DATA “IN” and DATA “OUT” XLR terminals located on all DMX fixtures (most controllers only have a DATA “OUT” terminal).

DMX Linking: DMX is a language allowing all makes and models of different manufacturers to be linked together and operate from a single controller, as long as all fixtures and the controller are DMX compliant. To ensure proper DMX data transmission, try to use the shortest cable path possible when linking several DMX fixtures. The order in which fixtures are connected in a DMX line does not influence the DMX addressing. For example, a fixture assigned a DMX address of 1 may be placed anywhere in a DMX line: at the beginning, at the end, or anywhere in the middle. When a fixture is assigned a DMX address of 1, the DMX controller knows to send DATA assigned to address 1 to that unit, no matter where it is located in the DMX chain.

Data Cable (DMX Cable) Requirements (For DMX Operation): This unit can be controlled via DMX-512 protocol and features 3 selectable DMX modes. Please refer to the **DMX Traits** section of this manual for detailed information. The DMX address can be set using the controls on the rear panel of the unit. Your unit and your DMX controller require a 3-pin XLR connector for data input/output. We recommend Accu-Cable DMX cables. If you are making your own cables, be sure to use standard 110-120 Ohm shielded cable (This cable may be purchased at almost all pro lighting stores). Your cables should be made with a male XLR connector on one end and a female XLR connector on the other. Also remember that DMX cable must be daisy chained and cannot be split.



DMX SETUP

Notice: Be sure to the figures below when making your own cables. Do not use the ground lug on the XLR connector. Do not connect the cable's shield conductor to the ground lug or allow the shield conductor to come in contact with the XLR's outer casing. Grounding the shield could cause a short circuit and erratic behavior.

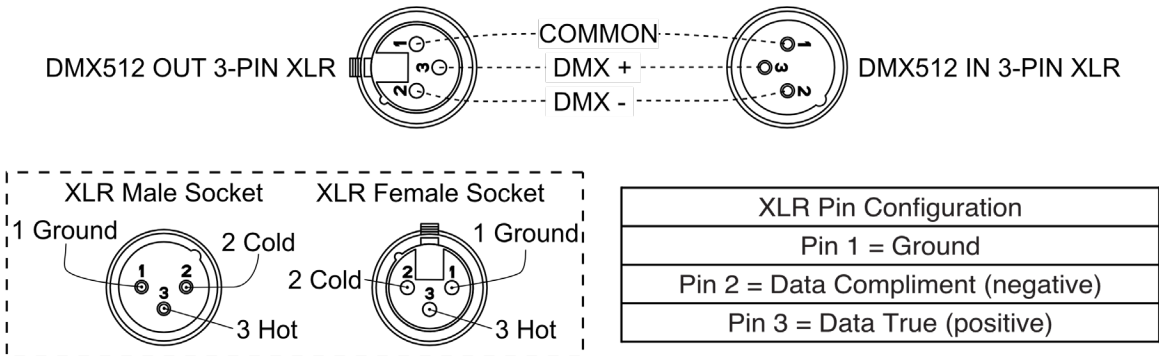

Special Note: Line Termination. When longer runs of cable are used, you may need to use a terminator on the last unit to avoid erratic behavior. A terminator is a 110-120 ohm 1/4 watt resistor which is connected between pins 2 and 3 of a male XLR connector (DATA + and DATA -). This unit is inserted in the female XLR connector of the last unit in your daisy chain to terminate the line. Using a cable terminator (ADJ part number Z-DMX/T) will decrease the possibilities of erratic behavior.

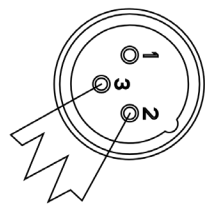

A DMX512 terminator reduces signal errors, avoiding most signal reflection interference. Connect PIN 2 (DMX-) and PIN 3 (DMX+) of the last fixture in series with a 120 Ohm, 1/4 W Resistor to terminate the DMX512.

5-Pin XLR DMX Connectors: Some manufacturers use 5-pin DMX-512 data cables for DATA transmission in place of 3-pin. 5-pin DMX fixtures may be integrated into a 3-pin DMX line with a 5-pin to 3-pin adapter cable. These adapters are readily available at most electronics stores. Follow the chart below for a proper conversion.

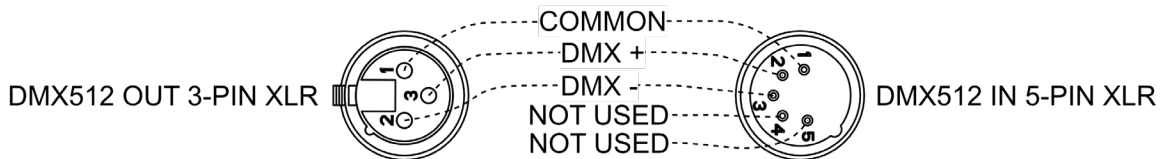

3-Pin XLR to 5-Pin XLR Conversion		
Ground/Shield	Pin 1	Pin 1
Data Compliment (- signal)	Pin 2	Pin 2
Data True (+ signal)	Pin 3	Pin 3
Not Used		Do Not Use
Not Used		Do Not Use

DMX SETUP

DMX Addressing:

All fixtures should be given a DMX starting address when using a DMX controller, in order to ensure that the correct fixture responds to the correct control signal. This digital starting address is the channel number from which the fixture starts to “listen” to the digital control signal sent out from the DMX controller. The assignment of this starting DMX address is achieved by setting the correct DMX address on the digital control display on the fixture.

You can set the same starting address for all fixtures or a group of fixtures, or set different addresses for each individual fixture. Setting all fixtures to the same DMX address will cause all fixtures to react in the same way; in other words, changing the settings of one channel will affect all the fixtures simultaneously.

If you set each fixture to a different DMX address, each unit will start to “listen” to the channel number you have set, based on the quantity of DMX channels of each fixture. That means changing the settings of one channel will only affect the selected fixture. For instance, when this unit is set to 10 Channel mode, you should set the starting DMX address of the first unit to 1, the second unit to 11 (1 + 10), the third unit to 21 (1 + 10 + 10), etc...

Channel Mode	Unit 1 Address	Unit 2 Address	Unit 3 Address	Unit 4 Address
4Ch	1	5	9	13
6Ch	1	7	13	19
9Ch	1	10	19	28
72Ch	1	73	145	217
74Ch	1	75	149	223

DMX TRAITS

MODE/CHANNELS					VALUES	FUNCTION
4Ch	6Ch	9Ch	72Ch	74Ch		
1	1	1				All Red Dimmer
					000 - 255	0 - 100%
2	2	2				All Green Dimmer
					000 - 255	0 - 100%
3	3	3				All Blue Dimmer
					000 - 255	0 - 100%
4	4	4				All Amber Dimmer
					000 - 255	0 - 100%
			1	1		Red 1 Dimmer
					000 - 255	0 - 100%
			2	2		Green 1 Dimmer
					000 - 255	0 - 100%
			3	3		Blue 1 Dimmer
					000 - 255	0 - 100%
			4	4		Amber 1 Dimmer
					000 - 255	0 - 100%
			5	5		Red 2 Dimmer
					000 - 255	0 - 100%
			6	6		Green 2 Dimmer
					000 - 255	0 - 100%
			7	7		Blue 2 Dimmer
					000 - 255	0 - 100%
			8	8		Amber 2 Dimmer
					000 - 255	0 - 100%
			9	9		Red 3 Dimmer
					000 - 255	0 - 100%
			10	10		Green 3 Dimmer
					000 - 255	0 - 100%
			11	11		Blue 3 Dimmer
					000 - 255	0 - 100%
			12	12		Amber 3 Dimmer
					000 - 255	0 - 100%
			13	13		Red 4 Dimmer
					000 - 255	0 - 100%
			14	14		Green 4 Dimmer
					000 - 255	0 - 100%

DMX TRAITS

MODE/CHANNELS					VALUES	FUNCTION
4Ch	6Ch	9Ch	72Ch	74Ch		
			15	15	000 - 255	Blue 4 Dimmer
						0 - 100%
			16	16	000 - 255	Amber 4 Dimmer
						0 - 100%
			17	17	000 - 255	Red 5 Dimmer
						0 - 100%
			18	18	000 - 255	Green 5 Dimmer
						0 - 100%
			19	19	000 - 255	Blue 5 Dimmer
						0 - 100%
			20	20	000 - 255	Amber 5 Dimmer
						0 - 100%
			21	21	000 - 255	Red 6 Dimmer
						0 - 100%
			22	22	000 - 255	Green 6 Dimmer
						0 - 100%
			23	23	000 - 255	Blue 6 Dimmer
						0 - 100%
			24	24	000 - 255	Amber 6 Dimmer
						0 - 100%
			25	25	000 - 255	Red 7 Dimmer
						0 - 100%
			26	26	000 - 255	Green 7 Dimmer
						0 - 100%
			27	27	000 - 255	Blue 7 Dimmer
						0 - 100%
			28	28	000 - 255	Amber 7 Dimmer
						0 - 100%
			29	29	000 - 255	Red 8 Dimmer
						0 - 100%
			30	30	000 - 255	Green 8 Dimmer
						0 - 100%
			31	31	000 - 255	Blue 8 Dimmer
						0 - 100%
			32	32	000 - 255	Amber 8 Dimmer
						0 - 100%

DMX TRAITS

MODE/CHANNELS					VALUES	FUNCTION
4Ch	6Ch	9Ch	72Ch	74Ch		
			33	33	000 - 255	Red 9 Dimmer
						0 - 100%
			34	34	000 - 255	Green 9 Dimmer
						0 - 100%
			35	35	000 - 255	Blue 9 Dimmer
						0 - 100%
			36	36	000 - 255	Amber 9 Dimmer
						0 - 100%
			37	37	000 - 255	Red 10 Dimmer
						0 - 100%
			38	38	000 - 255	Green 10 Dimmer
						0 - 100%
			39	39	000 - 255	Blue 10 Dimmer
						0 - 100%
			40	40	000 - 255	Amber 10 Dimmer
						0 - 100%
			41	41	000 - 255	Red 11 Dimmer
						0 - 100%
			42	42	000 - 255	Green 11 Dimmer
						0 - 100%
			43	43	000 - 255	Blue 11 Dimmer
						0 - 100%
			44	44	000 - 255	Amber 11 Dimmer
						0 - 100%
			45	45	000 - 255	Red 12 Dimmer
						0 - 100%
			46	46	000 - 255	Green 12 Dimmer
						0 - 100%
			47	47	000 - 255	Blue 12 Dimmer
						0 - 100%
			48	48	000 - 255	Amber 12 Dimmer
						0 - 100%
			49	49	000 - 255	Red 13 Dimmer
						0 - 100%
			50	50	000 - 255	Green 13 Dimmer
						0 - 100%

DMX TRAITS

MODE/CHANNELS					VALUES	FUNCTION
4Ch	6Ch	9Ch	72Ch	74Ch		
			51	51	000 - 255	Blue 13 Dimmer
						0 - 100%
			52	52	000 - 255	Amber 13 Dimmer
						0 - 100%
			53	53	000 - 255	Red 14 Dimmer
						0 - 100%
			54	54	000 - 255	Green 14 Dimmer
						0 - 100%
			55	55	000 - 255	Blue 14 Dimmer
						0 - 100%
			56	56	000 - 255	Amber 14 Dimmer
						0 - 100%
			57	57	000 - 255	Red 15 Dimmer
						0 - 100%
			58	58	000 - 255	Green 15 Dimmer
						0 - 100%
			59	59	000 - 255	Blue 15 Dimmer
						0 - 100%
			60	60	000 - 255	Amber 15 Dimmer
						0 - 100%
			61	61	000 - 255	Red 16 Dimmer
						0 - 100%
			62	62	000 - 255	Green 16 Dimmer
						0 - 100%
			63	63	000 - 255	Blue 16 Dimmer
						0 - 100%
			64	64	000 - 255	Amber 16 Dimmer
						0 - 100%
			65	65	000 - 255	Red 17 Dimmer
						0 - 100%
			66	66	000 - 255	Green 17 Dimmer
						0 - 100%
			67	67	000 - 255	Blue 17 Dimmer
						0 - 100%
			68	68	000 - 255	Amber 17 Dimmer
						0 - 100%

DMX TRAITS

MODE/CHANNELS					VALUES	FUNCTION
4Ch	6Ch	9Ch	72Ch	74Ch		
			69	69	000 - 255	Red 18 Dimmer 0 - 100%
			70	70	000 - 255	Green 18 Dimmer 0 - 100%
			71	71	000 - 255	Blue 18 Dimmer 0 - 100%
			72	72	000 - 255	Amber 18 Dimmer 0 - 100%
	5	5		73		Shutter
					000 - 031	Shutter Closed (LEDs Off)
					032 - 063	Shutter Open (LEDs On)
					064 - 095	Strobe Effect, slow to fast
					096 - 127	Shutter Open (LEDs On)
					128 - 159	Pulse Effect in Sequences
					160 - 191	Shutter Open (LEDs On)
					192 - 223	Random Strobe Effect, slow to fast
					224 - 255	Shutter Open (LEDs On)
	6	6		74		Master Dimmer
					000 - 255	0 - 100%
						Effects
					000 - 009	Off
					010 - 019	Static Color, Ch8 Select (Red, Green, Blue, Amber, Yellow Purple, Cyan, RGBA)
					020 - 029	Pulsing Effect, Ch9 Select Color
					030 - 039	Color Jump Effect
					040 - 049	Gradient Change Effect
					050 - 059	Pulse Change Effect, Ch9 Select Color
		7			060 - 069	Autorun Effect 1, Ch9 Select Color (cycle autorun)
					070 - 079	Autorun Effect 2, Ch9 Select Color
					080 - 089	Autorun Effect 3, Ch9 Select Color
					090 - 099	Autorun Effect 4, Ch9 Select Color
					100 - 109	Autorun Effect 5, Ch9 Select Color
					110 - 119	Autorun Effect 6, Ch9 Select Color
					120 - 129	Autorun Effect 7, Ch9 Select Color
					130 - 139	Autorun Effect 8, Ch9 Select Color
					140 - 149	Autorun Effect 9, Ch9 Select Color

DMX TRAITS

MODE/CHANNELS					VALUES	FUNCTION
4Ch	6Ch	9Ch	72Ch	74Ch		
		7				Effects (continued)
					150 - 159	Autorun Effect 10, Ch9 Select Color
					160 - 169	Autorun Effect 11, Ch9 Select Color
					170 - 179	Autorun Effect 12, Ch9 Select Color
					180 - 189	Autorun Effect 13, Ch9 Select Color
					190 - 199	Autorun Effect 14, Ch9 Select Color
					200 - 209	Autorun Effect 15, Ch9 Select Color
					210 - 229	Autorun Effect 16, Ch9 Select Color
					230 - 233	Sound Mode 1, Ch9 Select Color
					234 - 237	Sound Mode 2, Ch9 Select Color
					238 - 241	Sound Mode 3, Ch9 Select Color
					242 - 245	Sound Mode 4, Ch9 Select Color
					246 - 249	Sound Mode 5, Ch9 Select Color
				250 - 255	Sound Mode 6, Ch9 Select Color	
		8				Effects Adjustment
					000 - 255	When Effect channel is set to Static color mode: no function When Effect channel is set to Autorun Effect: speed adjustment, slow to fast When Effect channel is set to Sound Mode: sensitivity adjustment, least to most sensitive
		9				Color
					000 - 031	Default Color
					032 - 063	Red, Ch7 Manual Color Selection
					064 - 095	Green, Ch7 Manual Color Selection
					096 - 127	Blue, Ch7 Manual Color Selection
					128 - 159	Yellow, Ch7 Manual Color Selection
					160 - 191	Purple, Ch7 Manual Color Selection
					192 - 223	Cyan, Ch7 Manual Color Selection
				224 - 255	White, Ch7 Manual Color Selection	

PRIMARY-SECONDARY MODE

This function will allow you to link units together to run in a Primary-Secondary set-up, in which one unit will act as the controlling unit, and the others will react to the controlling unit's built-in programs. Any unit can act as a Primary or a Secondary, but only one unit in a given system can be programmed to act as the Primary.

Connections and Settings:

1. Daisy chain your units via the XLR connectors on the rear panel of each unit. Use standard XLR data cables to link your units together. Remember that the male XLR connector is the input and the female XLR connector is the output. The first unit in the chain (primary) will use the female XLR connector only, and the last unit in the chain will use the male XLR connector only.
2. The unit that has the Effect or Sound mode set in its system menu will be designated as the Primary. On the unit that will be the Primary, use the system menu to navigate to either EFxx (for Effects mode) or SUxx, then press ENTER.
3. Use the UP and DOWN buttons to select the Effects program (EF01 - EF20) or the Sound program (SU01 - SU06). Press ENTER to confirm.
4. If an Effects program has been selected, the user will now be able to set Effect Speed by using the UP and DOWN buttons to select SP01 - SP15. Alternately, if a Sound program has been selected, the user will now be able to set the Sound Sensitivity level by using the UP and DOWN buttons to select SE01 - SE15.
5. All other linked units should run as Secondary units, and should not have an LED Macro selected. The secondary unit(s) will now follow the programming of the primary unit.

MULTI UNIT POWER LINKING

This feature allows you to connect the fixtures to one another using the power cable input and output sockets.

The maximum number of units that can be linked in this manner is as follows:

- 5 units @ 120V power
- 10 units @ 230V power

DO NOT EXCEED THIS MAXIMUM NUMBER WHEN POWER LINKING UNITS!

All linked units must be of the same make and model type. Do not mix and match units!

FUSE REPLACEMENT

Disconnect the unit from its power source, and remove the power cord from the unit. The fuse is located on the rear of the unit near the power in and data in ports, as shown in the illustration below. Remove the bad fuse and replace with a new one. **Replace only with a new fuse of the same T2A 250V rating!**

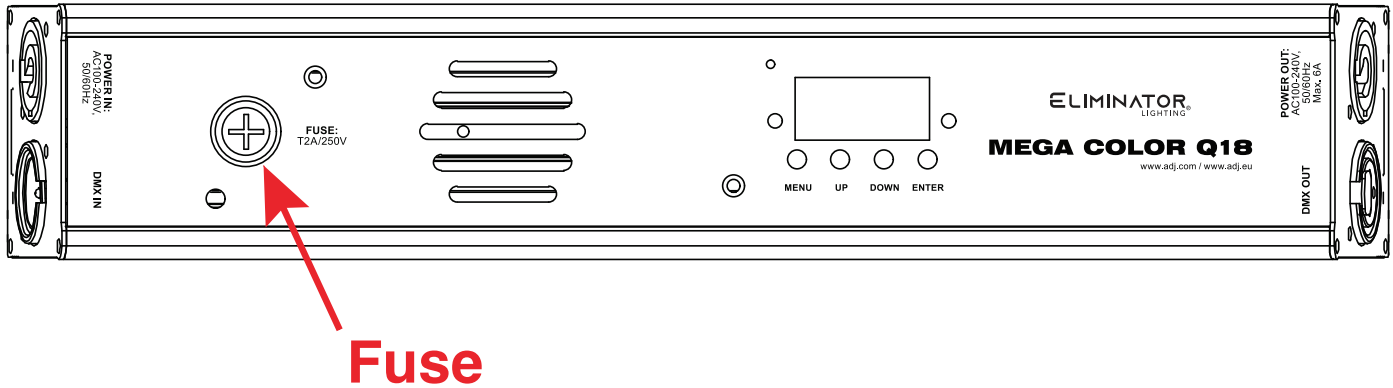

CLEANING

Due to fog residue, smoke, and dust, cleaning the internal and external optical lenses must be carried out periodically to optimize light output.

- Periodically use normal glass cleaner and a soft cloth to wipe down the outside casing and external optics.
- Always be sure to dry all parts completely before plugging the unit back in.

Cleaning frequency depends on the environment in which the fixture operates (i.e. smoke, fog residue, dust, dew).

SPECIFICATIONS

- LED: 18 × 4W (RGBA, 4-in-1)
- Beam Angle: 25°
- LED Lifespan: 50,000 hours
- Fully Pixel Mappable
- Control System: DMX512, Auto Mode, Primary-Secondary Mode, Sound Active
- DMX Channel Modes: 4 / 6 / 9 / 72 / 74
- DMX Signal Cable: 3-pin XLR connector
- Built-in Programs, Primary/Secondary control
- Strobe, color selection programs, color changing
- Voltage: AC100V–240V, 50–60Hz
- Product Dimensions: 39.76" × 2.36" × 3.94" (101 × 6 × 10 cm)
- Net Weight: 4.62 lb. (2.1 kg)
- IP Rating: IP20

DIMENSIONAL DRAWINGS

