

ELATION[®]

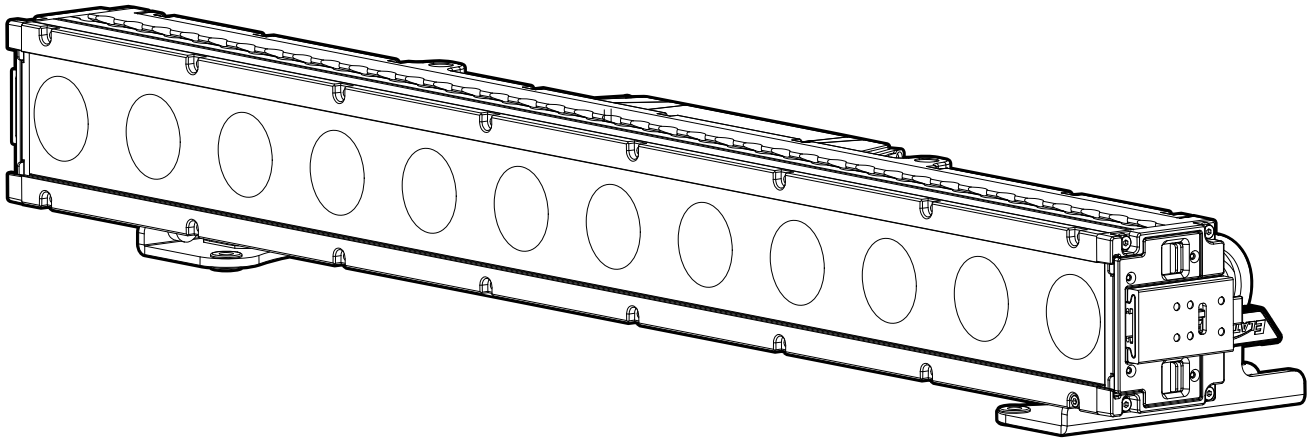

SIX+ BAR L User Manual

©2026 **ELATION PROFESSIONAL** all rights reserved. Information, specifications, diagrams, images, and instructions herein are subject to change without notice. ELATION PROFESSIONAL logo and identifying product names and numbers herein are trademarks of ELATION PROFESSIONAL. Copyright protection claimed includes all forms and matters of copyrightable materials and information now allowed by statutory or judicial law or hereinafter granted. Product names used in this document may be trademarks or registered trademarks of their respective companies and are hereby acknowledged. All non-ELATION brands and product names are trademarks or registered trademarks of their respective companies.

ELATION PROFESSIONAL and all affiliated companies hereby disclaim any and all liabilities for property, equipment, building, and electrical damages, injuries to any persons, and direct or indirect economic loss associated with the use or reliance of any information contained within this document, and/or as a result of the improper, unsafe, insufficient and negligent assembly, installation, rigging, and operation of this product.

Elation Professional USA | 6122 S. Eastern Ave. | Los Angeles, CA. 90040

323-582-3322 | www.elationlighting.com | info@elationlighting.com

Elation Professional B.V. | Junostraat 2 | 6468 EW Kerkrade, The Netherlands

+31 45 546 85 66 | www.elationlighting.eu | info@elationlighting.eu

Elation Professional Mexico | AV Santa Ana 30 | Parque Industrial Lerma, Lerma, Mexico 52000

+52 (728) 282-7070

DOCUMENT VERSION



Due to additional product features and/or enhancements, an updated version of this document may be available online. Please scan the QR Code with your mobile device or visit www.elationlighting.com for the latest revision/update of this manual, before installation and/or programming.

Date	Document Version	Software Version	DMX Channel Mode	Notes
05/29/24	1.0	1.01	1/3/6/9/13/16/16/22/22/ 34/44/58/82/154/72	Initial Release
07/24/24	1.1	1.01	N/A	Added pixel configurations
04/13/26	1.2	N/C	No Change	Update Specifications
06/17/26	1.3	N/C	No Change	Updated: General Info, IP65 Rated, Specifications; Added Index

CONTENTS

General Information	4
IP65 Rated	5
Safety Guidelines	6
Overview	8
Torque Settings for Screws	9
IP Test Parameters	10
Installation Guidelines	11
Accessory Installation	19
Remote Device Management (RDM)	21
System Menu/Software Updates	22
Dimmer Modes & Curves	25
DMX Traits	26
Emulation DMX Traits for SixBar 1000	36
Pixel Grouping & Flip Diagram	40
Color Temperature	41
Virtual Colors	42
Error Codes	43
Maintenance Guidelines	44
Specifications	45
Ordering Information Error Codes	47
Index	48

GENERAL INFORMATION

FOR PROFESSIONAL USE ONLY

INTRODUCTION

Please read and understand the instructions in this manual carefully and thoroughly before attempting to operate this device. These instructions contain important safety and use information.

COOLING

After usage, the lamp may be switched off, but the fixture should remain connected to power in order to allow the fan time to cool down the fixture.

UNPACKING

Every device has been thoroughly tested and has been shipped in perfect operating condition. Carefully check the shipping carton for damage that may have occurred during shipping. If the carton is damaged, carefully inspect the device for damage, and be sure all accessories necessary to install and operate the device have arrived intact. In the event damage has been found or parts are missing, please contact our customer support team for further instructions. Please do not return this device to your dealer without first contacting customer support. Please do not discard the shipping carton in the trash. Please recycle whenever possible.

BOX CONTENTS

- Safety Cable
- IP65 Locking Power Cable
- Frost Filter
- Glare Shield
- Fixture Interconnect Splice

CUSTOMER SUPPORT

Contact ELATION Service for any product related service and support needs. Also visit forums.elationlighting.com with questions, comments or suggestions.

ELATION SERVICE USA - Monday - Friday 8:00am to 4:30pm PST

323-582-3322 | support@elationlighting.com

ELATION SERVICE EUROPE - Monday - Friday 08:30 to 17:00 CET

+31 45 546 85 63 | support@elationlighting.eu

REPLACEMENT PARTS please visit parts.elationlighting.com

LIMITED WARRANTY

For up-to-date warranty information regarding your device, please visit Elation's warranty information page online or scan the QR codes below.



USA: <https://www.elationlighting.com/warranty-information>



EU: https://www.elationlighting.eu/terms_and_conditions

It is strongly recommended to power the fixture down completely when not in use. Doing so will reduce wear on the fixture due to sustained or extended operational periods, thereby maximizing its operational lifespan.

IP65 RATED

The International Protection (IP) rating system is commonly expressed as “IP” (Ingress Protection) followed by two numbers (i.e. IP65), where the numbers define the degree of protection. The first digit (Foreign Bodies Protection) indicates the extent of protection against particles entering the fixture, and the second digit (Water Protection) indicates the extent of protection against water entering the fixture. An **IP65** rated lighting fixture is designed and tested to protect against the ingress of dust (**6**), and low-pressure water jets from any direction (**5**).

THIS FIXTURE IS INTENDED FOR TEMPORARY OUTDOOR USE ONLY!

Maritime/Seaside Environment Installations: A maritime/seaside environment is adjacent to the sea and caustic to electronics through exposure to atomized salt water and humidity, whereas a coastal environment extends 5 miles inland.

Maritime installations require additional preparation, and additional service intervals may be needed given the maritime use. In general, IP ratings presuppose freshwater conditions VS maritime conditions, which are typically more “caustic” to IP fixtures (both internally and externally). A duty-cycle may also be needed when units are not in use. During times of high humidity and colder temperatures, condensation may occur internally so the fixture may require a duty-cycle to bring it up to running temperature, allowing any accumulation of moisture to be expelled via the vent valve. Recommendations can change based on installation environmental circumstances.

NOTE: NOT ALL FEATURES LISTED ARE AVAILABLE ON ALL FIXTURES; THE FOLLOWING INSTRUCTIONS MAY NOT APPLY. CONTACT SUPPORT FOR ADDITIONAL DETAILS.

Exterior Maintenance: Inspect the exterior every 30-days. The unit must be powered off/disconnected. The chassis should be inspected for any signs of contaminants. Inspect optics to determine if the lens is obstructed, then clean optics and chassis accordingly. Based on initial finding, schedule maintenance accordingly, keeping in mind that exterior maintenance will be required. Even if the luminaires are NOT in use, maintenance will still be needed given its location (exterior use). The use of a durable type of wax on the chassis is recommended since it will help prevent contaminant build up. Inspect both power and data lines for any signs of contaminants or corrosion. Periodically reapplying di-electric grease, especially in coastal environments. If any signs of corrosion/contaminants are present, clean thoroughly, and/or replace connectors, then reapply di-electric grease. Typically, this should be done annually, or any time an opportunity presents itself. As a preventive measure, annual replacement of both vent valves is recommended. The vent valve membrane can become contaminated and/or clogged causing improper venting of humidity within the luminaire. Inspect all mounting hardware as a precaution.

Interior Maintenance: Inspect the interior every 30-days. The unit must be powered off/disconnected.

- Inspect zoom/focus mechanism, clean optics, lubricate linear bearings (Krytox oil) as needed, inspect belts for wear
- Inspect all rotating effect wheels, manually rotate them, note any resistance
- Inspect all remaining rotating belts for any wear
- Inspect all fans, clean as needed, check rotation, check connections
- Inspect CMY module, manually move flags and check for signs of resistance, and if needed, clean guide rods first, then reapply a thin layer of grease (moly lube)
- Clean interior with low-volume compressed air, then clean optics prior to reassembly of head covers

Although the base has limited moving parts, the pan belt should also be inspected for wear. Remember to always perform an IP test anytime a cover is removed.

There is no specific time frame regarding the routine replacement of parts such as belts/stepper motors, PCBs, or LEDs. These items should only be replaced on an as needed bases, except for cooling fans, which should be replaced once the luminaries reach 10,000-hours. This is a prophylactic measure intended to keep the unit running as cool as possible, insuring proper function of all internal components. A complete service breakdown is available, please contact service@elationlighting.com for any needed parts or manuals.

SAFETY GUIDELINES

This fixture is a sophisticated piece of electronic equipment. To guarantee smooth operation, it is important to follow all instructions and guidelines in this manual. Elation Professional is not responsible for injury and/or damages resulting from the misuse of this fixture due to the disregard of the information printed in this manual. Only qualified and/or certified personnel should perform installation of this fixture and only the original rigging parts included with this fixture should be used for installation. Any modifications to the fixture and/or the included mounting hardware will void the original manufacturer's warranty and increase the risk of damage and/or personal injury.



PROTECTION CLASS 1 - FIXTURE MUST BE PROPERLY GROUNDED.



THERE ARE NO USER SERVICEABLE PARTS INSIDE THIS UNIT. DO NOT ATTEMPT ANY REPAIRS YOURSELF. DOING SO WILL VOID YOUR MANUFACTURER'S WARRANTY. DAMAGES RESULTING FROM MODIFICATIONS TO THIS DEVICE AND/OR THE DISREGARD OF SAFETY INSTRUCTIONS AND GUIDELINES IN THIS MANUAL VOID THE MANUFACTURER'S WARRANTY AND ARE NOT SUBJECT TO ANY WARRANTY CLAIMS AND/OR REPAIRS.



**DO NOT PLUG THIS UNIT INTO A DIMMER PACK
DO NOT REMOVE THE COVER UNDER ANY CONDITIONS
NEVER OPERATE THIS UNIT WITH THE CASING REMOVED
UNPLUG FROM POWER DURING LONG PERIODS OF NON-USE
DISCONNECT POWER BEFORE PERFORMING MAINTENANCE**

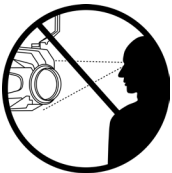

**NEVER LOOK DIRECTLY INTO THE LIGHT SOURCE!
RETINA INJURY RISK - MAY INDUCE BLINDNESS!
SENSITIVE PERSONS MAY SUFFER AN EPILEPTIC SHOCK!**



**FIXTURE SHOULD BE PLACED A MINIMUM OF 1.0 FOOT (0.3 METERS) FROM ANY NEARLY OBJECTS OR SURFACES.
FIXTURE SHOULD BE PLACED A MINIMUM OF 1.6 FEET (0.5 METERS) FROM ANY FLAMMABLE MATERIALS.
MAXIMUM AMBIENT OPERATING TEMPERATURE IS 113°F (45°C)**

SAFETY GUIDELINES

! CAUTION

**HIGH
INTENSITY
ULTRAVIOLET
LIGHT**



**AVOID DIRECT EYE & SKIN EXPOSURE.
WEAR PROPER EYE & SKIN PROTECTION.
SEE MANUAL FOR SAFETY INSTRUCTIONS.**

RISK GROUP 3 - RISK OF EXPOSURE TO ULTRAVIOLET UV RADIATION! FIXTURE EMITS HIGH INTENSITY WAVELENGTH OF ULTRAVIOLET UV LIGHT FROM THE UV COLOR FILTER. WEAR PROPER EYE AND SKIN PROTECTION. AVOID PROLONGED PERIODS OF EXPOSURE TO UV COLOR FILTER. AVOID WEARING WHITE COLOR CLOTHING AND/OR USING UV PAINTS ON SKIN. AVOID DIRECT EYE AND/OR SKIN EXPOSURE AT DISTANCES LESS THAN 10 feet (3m). DO NOT OPERATE FIXTURE WITH DAMAGED/MISSING EXTERNAL COVERS. DO NOT LOOK DIRECTLY INTO THE UV LIGHT AND/OR VIEW UV LIGHT DIRECTLY WITH OPTICAL INSTRUMENTS THAT MAY CONCENTRATE THE LIGHT/RADIATION OUTPUT.

INDIVIDUALS SUFFERING FROM A RANGE OF EYE CONDITIONS, SUNLIGHT EXPOSURE DISORDERS, OR INDIVIDUALS USING PHOTSENSITIVE MEDICATION, MAY RECEIVE DISCOMFORT IF EXPOSED TO THE ULTRAVIOLET UV LIGHT EMITTED FROM THE UV LED.

- **DO NOT TOUCH** the fixture housing during operation. Turn OFF the power and allow approximately 15 minutes for the fixture to cool down before serving.
- **DO NOT** shake fixture, avoid brute force when installing and/or operating fixture.
- **DO NOT** operate fixture if the power cord is frayed, crimped damaged and/or if any of the power cord connectors are damaged and do not insert into the fixture securely with ease.
- **NEVER** force a power cord connector into the fixture. If the power cord or any of its connectors are damaged, replace it immediately with a new one of similar power rating.
- **DO NOT** block any air ventilation slots.
- All fan and air inlets must remain clean and never blocked.
- Allow approx.6”(15cm) between fixture and other devices or a wall for proper cooling.
- Always disconnect fixture from main power source before performing any type of service and/or cleaning procedure. Only handle the power cord by the plug end, never pull out the plug by tugging the wire portion of the cord.
- During the initial operation of this fixture, a light smoke or smell may emit from the interior of the fixture. This is a normal process and is caused by excess paint in the interior of the casing burning off from the heat associated with the lamp and will decrease gradually over time.
- Consistent operational breaks will ensure the fixture will function properly for many years.
- **ONLY** use the original packaging and materials to transport the fixture in for service.

OVERVIEW

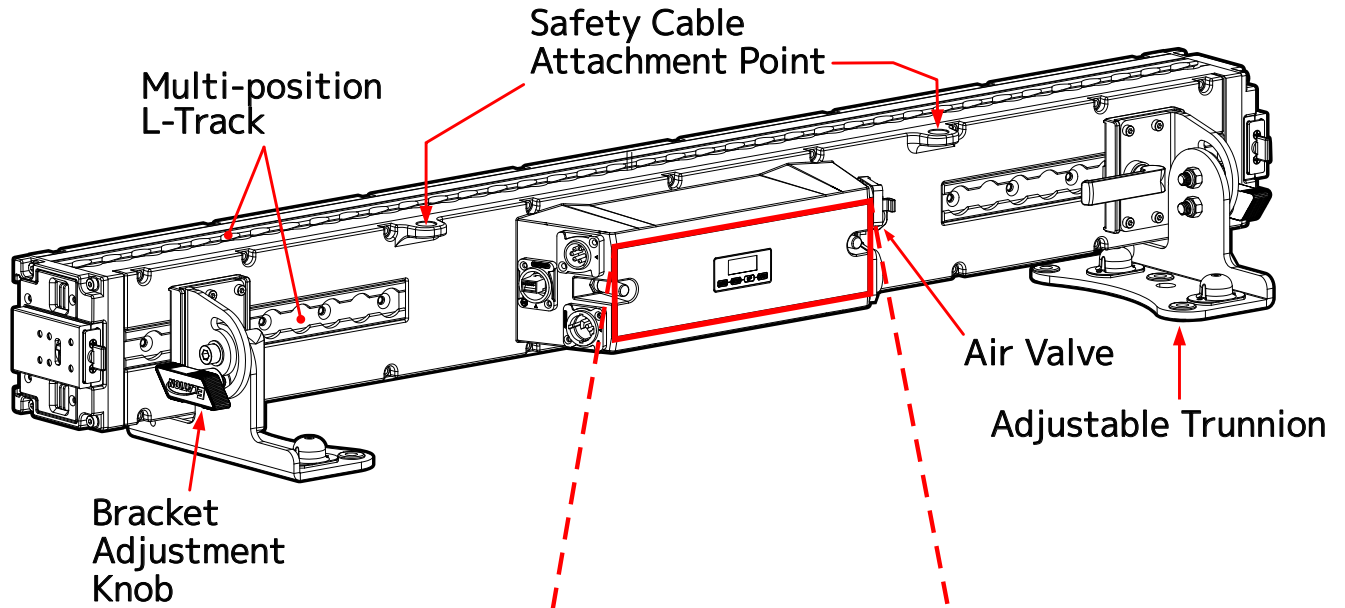
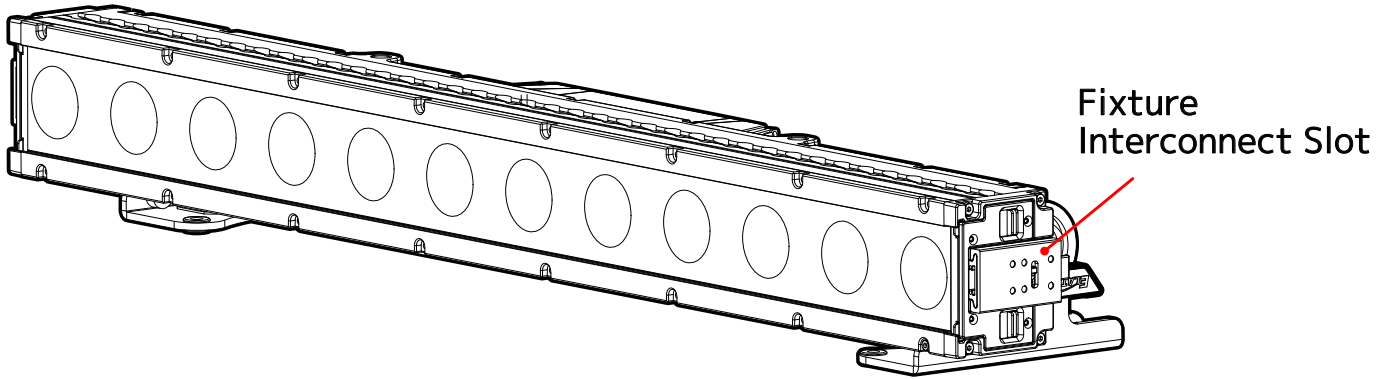

Display Screen

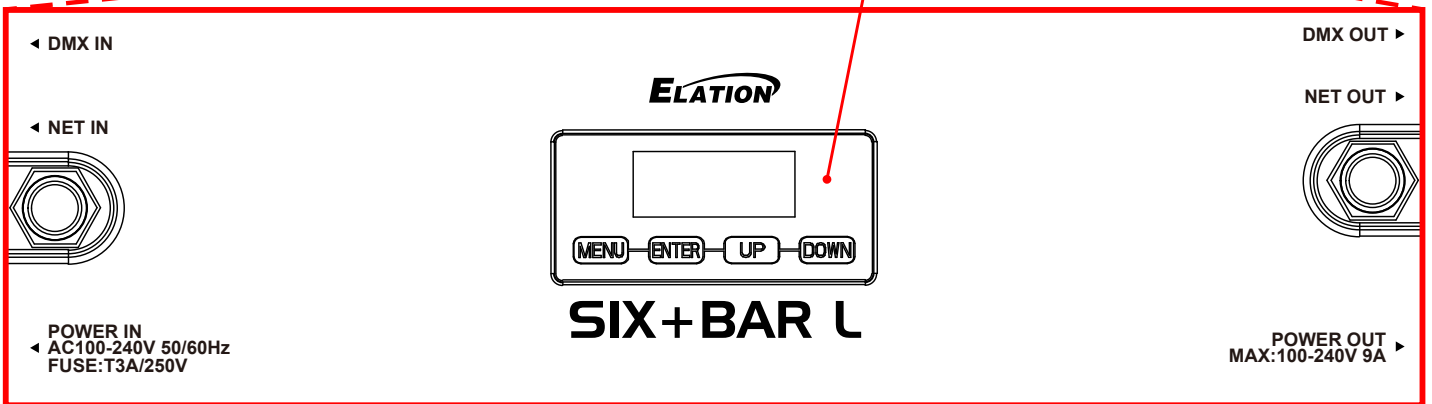

TORQUE SETTINGS FOR SCREWS

Pressure Strip
(13 ± 0.5 /Kgf.cm)

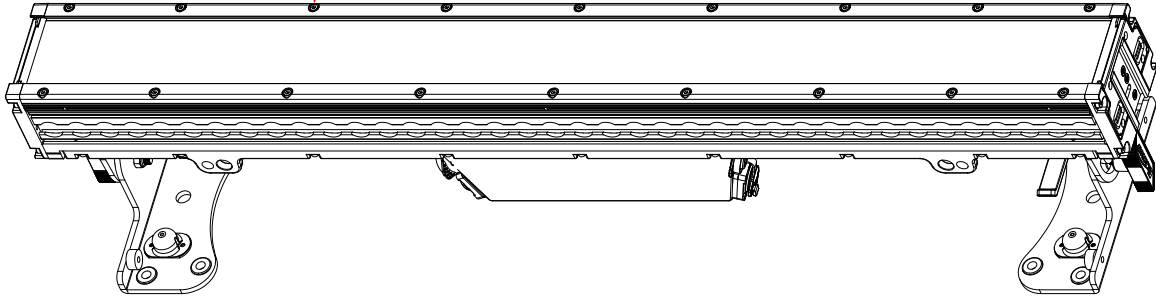

Adjustable Trunnion
(10 ± 0.5 /Kgf.cm)

Rear Cover
(13 ± 0.5 /Kgf.cm)

Fixture Interconnect Slot
(10 ± 0.5 /Kgf.cm)

Multi-Position L-Track
(10 ± 0.5 /Kgf.cm)

End Cover
(13 ± 0.5 /Kgf.cm)

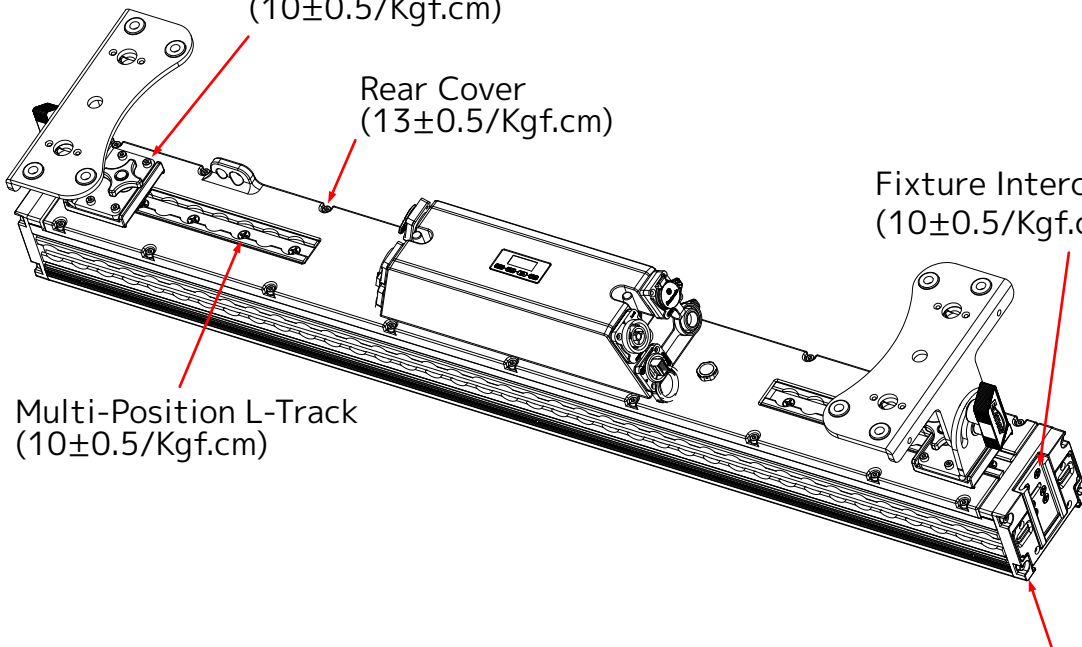

**CAUTION! DO NOT OVER TORQUE SCREWS AS THIS CAN CAUSE LEAKAGE ISSUES!
TO CONFIRM THE IP65 INTEGRITY, TEST FIXTURE USING THE ELATION IP TESTER. CONTACT
ELATION SERVICE FOR MORE DETAILS.**

IP TEST PARAMETERS

Following any repair or maintenance procedure that requires disassembly of the fixture, use Elation's IP Tester to confirm the IP integrity of the fixture. The air valve is located on the back panel next to the display screen, as shown in the diagram below. Please contact Elation Service for information regarding the Elation IP Tester, or visit the product information page online at: <https://www.elationlighting.com/ip-tester>



CAUTION! THE USE OF PROTECTIVE GLOVES AND SAFETY GOGGLES IS STRONGLY RECOMMENDED WHILE PERFORMING THE IP PRESSURE TEST! AVOID PLACING YOUR FACE, EYES, HANDS, ETC IN PROXIMITY TO THE LENS OF THE FIXTURE WHILE PERFORMING THE TEST!

DE-HUMIDIFICATION: IP65 fixtures operating in high-humidity environments may experience residual fogging or condensation. Such fogging will not affect the fixture, and can be removed using the following procedure: position the unit with the air valve pointing upwards, then open the air valve and run the unit for 1-2 hours after reaching operating temperature. Then, while the fixture is still hot, re-install the air valve and allow the unit to cool down. Please note: this procedure should be performed in a dry, climate-controlled environment. Avoid additional fogging by drying the fixture completely before placing into a road case.

Elation Product	Minimum Value		Maximum Value		Inflation Time	Balance Time	Inspection Time	Leakage
	Kpa	Psi	Kpa	Psi	S	S	S	Pa
Elation SIX+ BAR L	20	3	23	3	30	15	15	>100

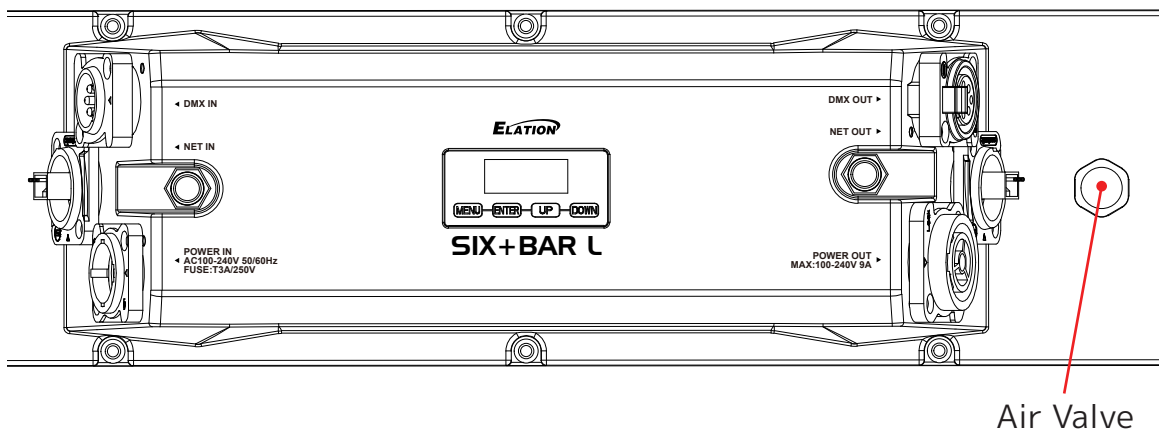

INSTALLATION GUIDELINES



FLAMMABLE MATERIAL WARNING

Keep fixture minimum 5.0 feet (1.5m) away from flammable materials and/or pyrotechnics.



ELECTRICAL CONNECTIONS

A qualified electrician should be used for all electrical connections and/or installations.



MINIMUM DISTANCE TO OBJECTS/SURFACES IS 1 FOOT (0.3 METERS)



MINIMUM DISTANCE OF FLAMMABLE MATERIALS FROM THE SURFACE IS 1.6 FEET (0.5 METER)



MAXIMUM AMBIENT TEMPERATURE 113° F (45°C)



DO NOT INSTALL THE FIXTURE IF YOU ARE NOT QUALIFIED TO DO SO!

Fixture **MUST** be installed following all local, national, and country commercial electrical and construction codes and regulations.

Before rigging/mounting a single fixture or multiple fixtures to any metal truss/structure or placing the fixture(s) on any surface, a professional equipment installer **MUST** be consulted to determine if the metal truss/structure or surface is properly certified to safely hold the combined weight of the fixture(s), clamps, cables, and accessories.

Fixture(s) should be installed in areas outside walking paths, seating areas, or away from areas where unauthorized personnel might reach the fixture by hand.

NEVER stand directly below the fixture(s) when rigging, removing, or servicing.

Overhead fixture installation must always be secured with a secondary safety attachment, such as an appropriately rated safety cable.

Allow approximately 15 minutes for the fixture to cool down before servicing.

INSTALLATION GUIDELINES

CLAMP INSTALLATION

This device features a mounting clamp attachment point built into the Adjustable Trunnions, as well as a safety cable attachment point located on the bottom of the fixture.

OMEGA BRACKETS WITH CLAMP INSTALLATION

Insert the Omega Brackets into the matching holes in the Adjustable Trunnions. Secure the Omega Brackets to the fixture by turning each quick-lock fastener $\frac{1}{4}$ turn clockwise; making sure the fastener is completely locked.

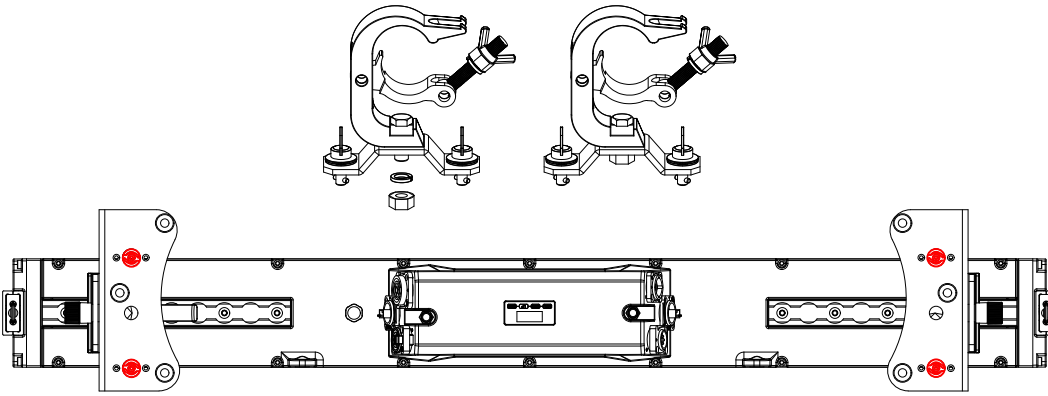

SAFETY CABLE

ALWAYS ATTACH AN APPROPRIATELY RATED SAFETY CABLE WHENEVER INSTALLING THIS FIXTURE IN A SUSPENDED ENVIRONMENT TO ENSURE THE FIXTURE WILL NOT FALL IF THE CLAMP FAILS.

IF THE FIXTURES ARE PART OF A LARGER ARRAY, ATTACH A SAFETY CABLE TO THE SAFETY CABLE ATTACHMENT POINT ON THE BACK OF EACH FIXTURE. FOR RIGGING PURPOSES, SECURE THE TOP SAFETY CABLE TO A FIXED POINT AND LOOP EACH SUBSEQUENT SAFETY CABLE THROUGH THE ONE ABOVE IT.

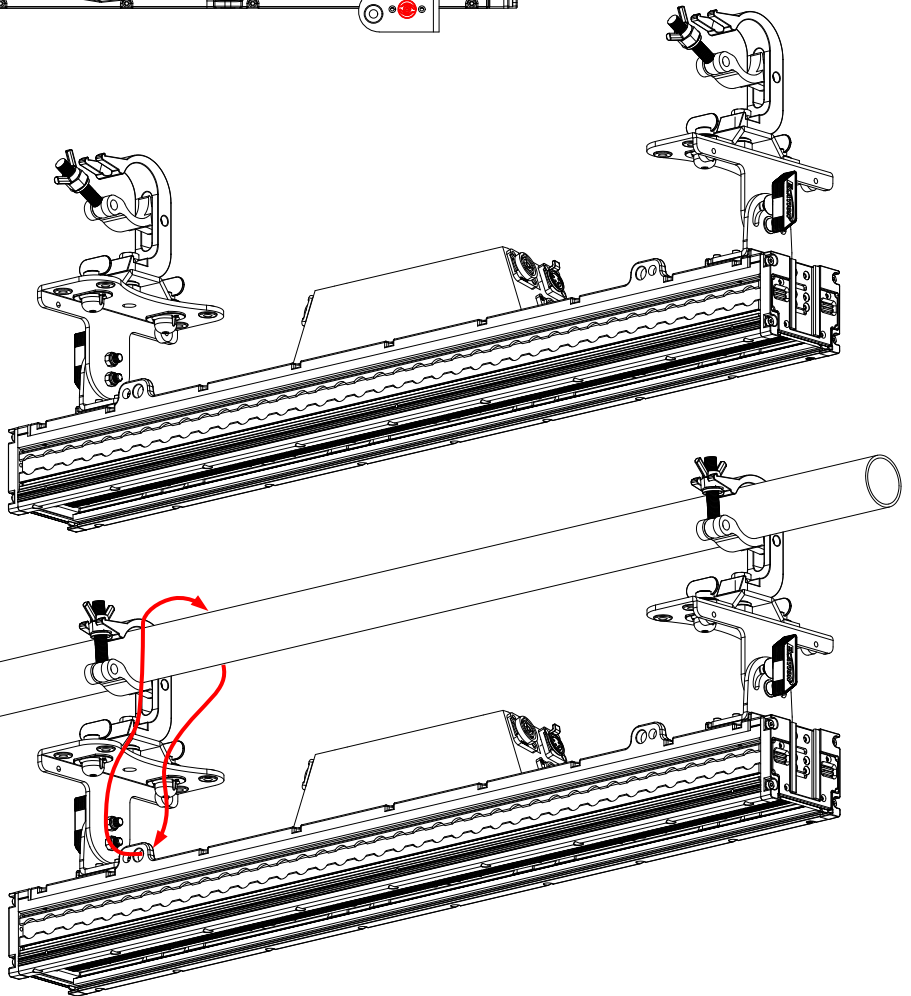

MOUNTING THE FIXTURE ON A TRUSS USING CLAMPS WITH OMEGA BRACKETS

When mounting the fixture to a truss, be sure to secure an appropriately rated professional grade rigging clamp to the included **Omega Brackets** using an M10 or M12 screw fitted through the center hole of the **Omega Brackets**. The fixture provides a built-in rigging point for a **SAFETY CABLE** (not included). Be sure to use the designated rigging points for the safety cable and never secure a safety cable to a carrying handle.

INSTALLATION GUIDELINES

L-TRACK MOUNTING

This fixture's L-track mounting system enables the user to slide the mounting clamps along the tracks and secure them in the desired position. The L-tracks are situated on the rear, and along the sides of the fixture. Special L-track mounting clamps, which feature an L-track attachment rail instead of a mounting bolt hole, are available in both standard and extended lengths. Similarly, L-track adapters are also available, which can be fitted to any standard mounting clamp.

To attach an L-track clamp or adapter, simply insert the attachment rail into the matching track on the fixture, slide it to the desired location, and tighten the fastener knob on the attachment to ensure it is securely in place.

When utilizing the L-track for rigging, the maximum capacity is 6 fixtures, or 187 lbs (84.82 kg).

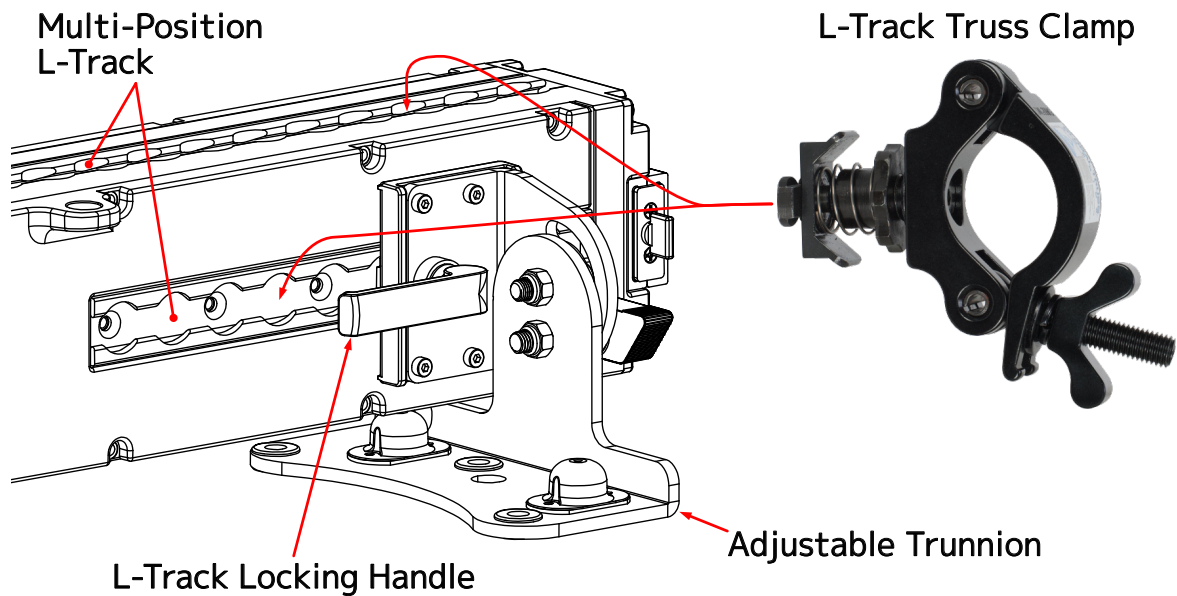

INSTALLATION GUIDELINES

FIXTURE INSTALLATION

The Elation SIX+ BAR L is fully operational in three different mounting positions, hanging upside-down, mounted sideways on trussing, or set on a flat level surface. Always use and install the supplied safety cable as a safety measure to prevent accidental damage and/or injury in the event the clamp fails.

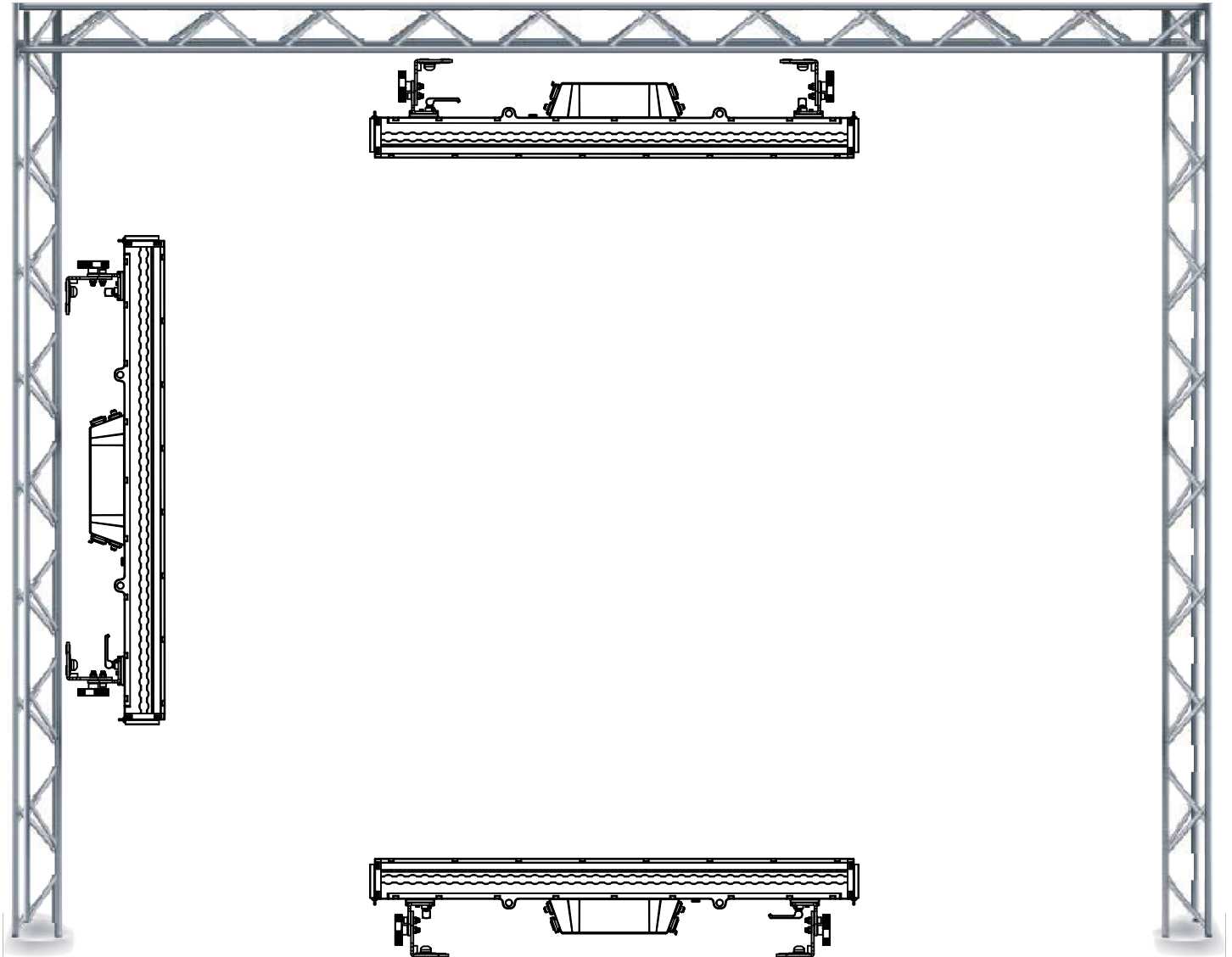

FALLING FIXTURES CAN CAUSE SEVERE INJURY OR SERIOUS EQUIPMENT DAMAGE! FOR THIS REASON, FIXTURES SHOULD BE INSTALLED AND INSPECTED ONLY BY QUALIFIED PERSONNEL. DO NOT INSTALL THE UNIT IF YOU LACK THE QUALIFICATIONS TO DO SO, OR IF YOU HAVE DOUBTS ABOUT THE SAFETY AND SECURITY OF THE INSTALLATION SETUP OR LOCATION!



ALWAYS ATTACH A SAFETY CABLE WHENEVER INSTALLING THIS FIXTURE IN A SUSPENDED ENVIRONMENT TO ENSURE THE FIXTURE WILL NOT FALL IF THE CLAMP FAILS.

INSTALLATION GUIDELINES

FIXTURE INTERCONNECTORS

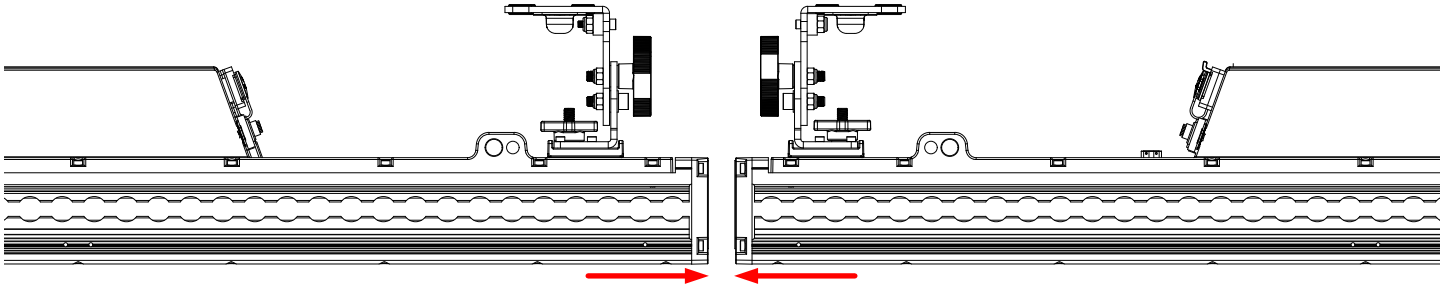

To connect the fixtures end-to-end, ensure that the interconnect slots are flush.

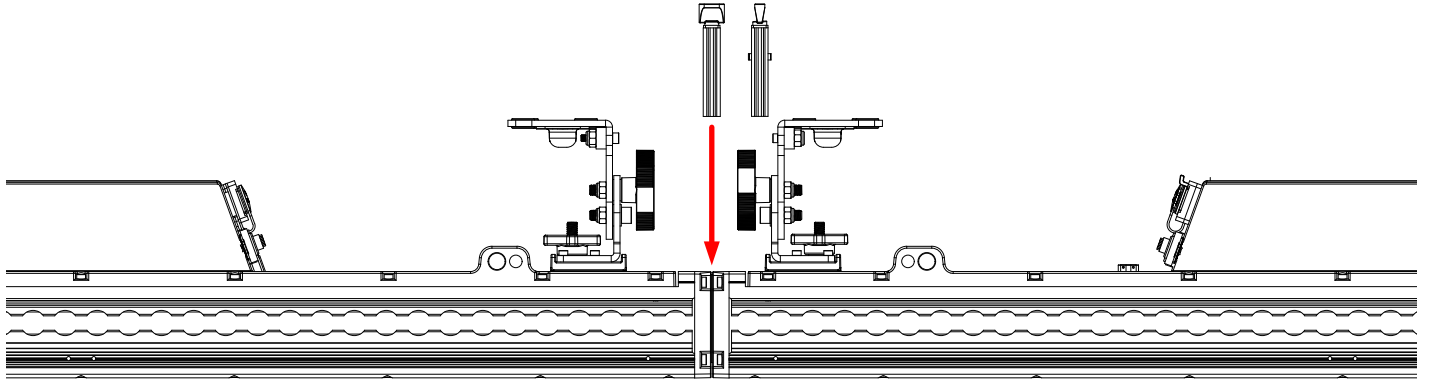

Fully insert the splice lock. Once the splice lock is fully seated, turn the lock tab to engage it, rotating the lock tab into the interconnect lock slot.

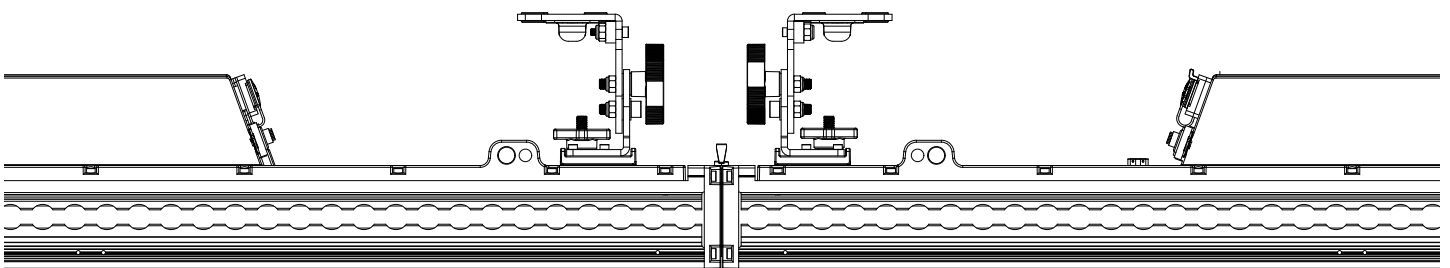
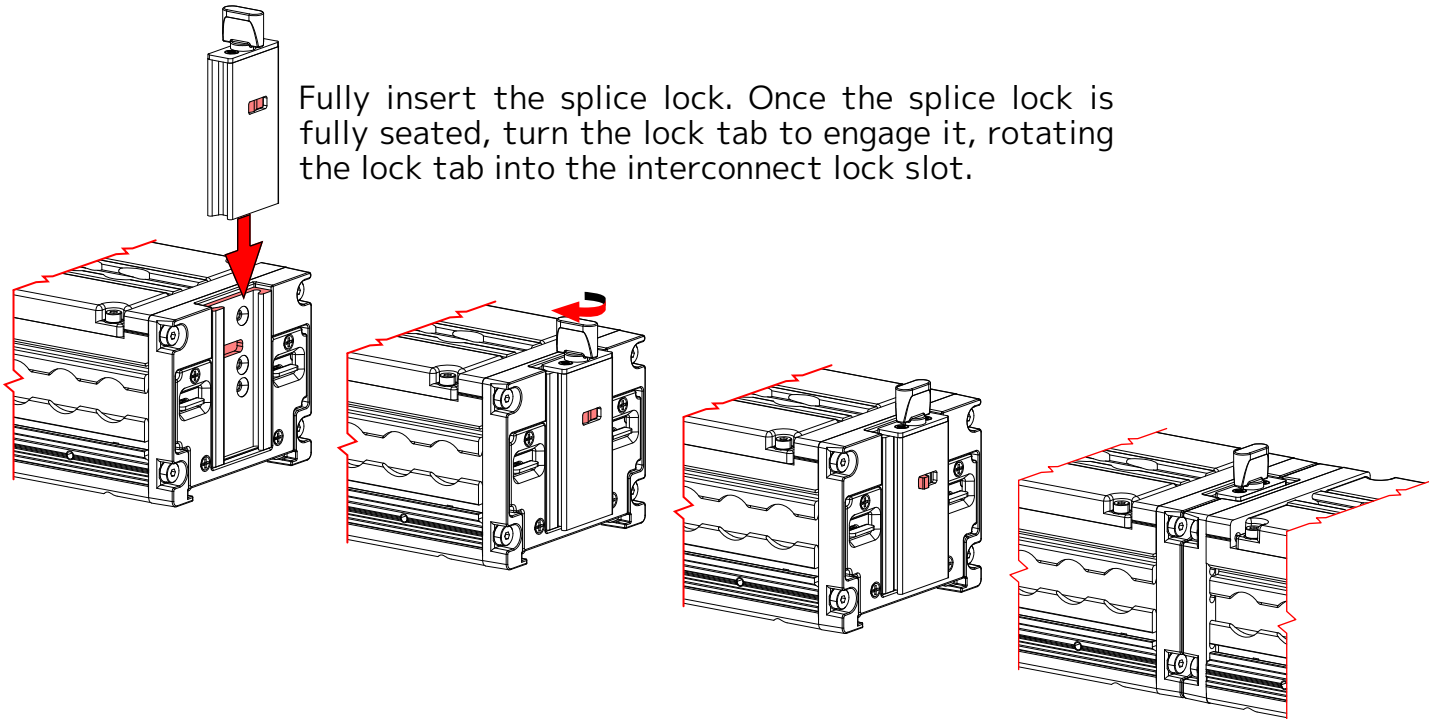

INSTALLATION GUIDELINES

RIGGING LIMIT

HORIZONTAL SUSPENSION

When utilizing the provided Trunnions for rigging in a horizontal array orientation, the maximum capacity is 3 fixtures, or 96 lbs (43.54 kg). However, if employing the L-Track for rigging in the same orientation, the maximum capacity increases to 6 fixtures, or 187 lbs (84.82 kg).

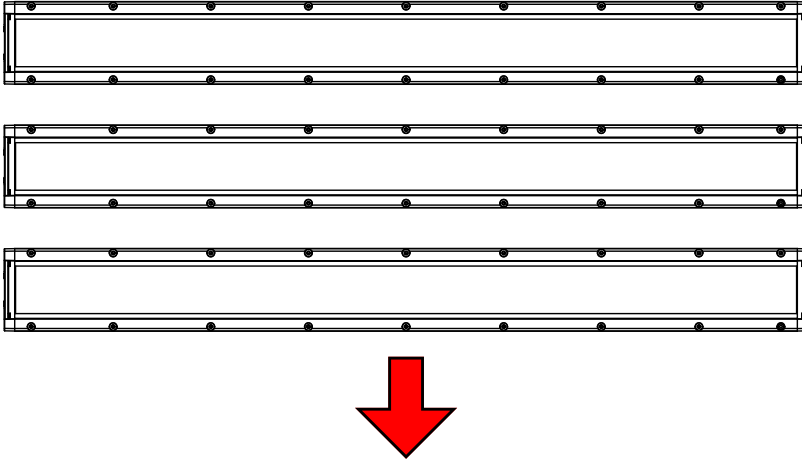

VERTICAL SUSPENSION

When rigging vertically with Interconnect Splices to connect fixtures, the maximum capacity is 6 fixtures, or 187 lbs (84.82 kg).

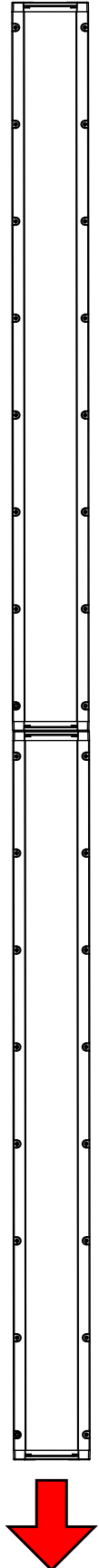

INSTALLATION GUIDELINES

ART-NET | sACN CONNECTION

When connecting fixture to a network switch to control multiple devices, a Gigabit Ethernet Switch that supports IGMP (Internet Group Management Protocol) is required. Using a Gigabit Ethernet Switch that does not support IGMP can cause erratic behavior of all connected devices to the switch.

POWER AND DATA CABLES



REGARDLESS OF FIXTURE ORIENTATION, TO MAINTAIN THE IP65 RATING INTEGRITY OF THE FIXTURE, ALL CABLES MUST BE ROUTED TOWARDS THE GROUND TO PREVENT WATER ACCUMULATION AROUND THE CONNECTIONS.

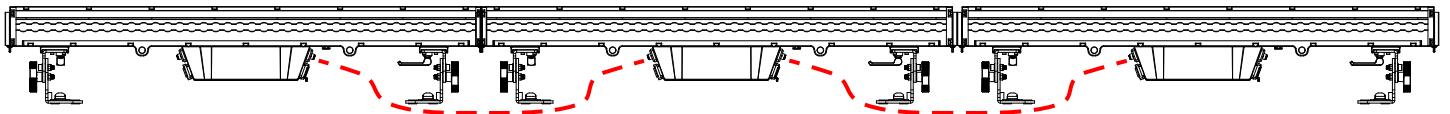
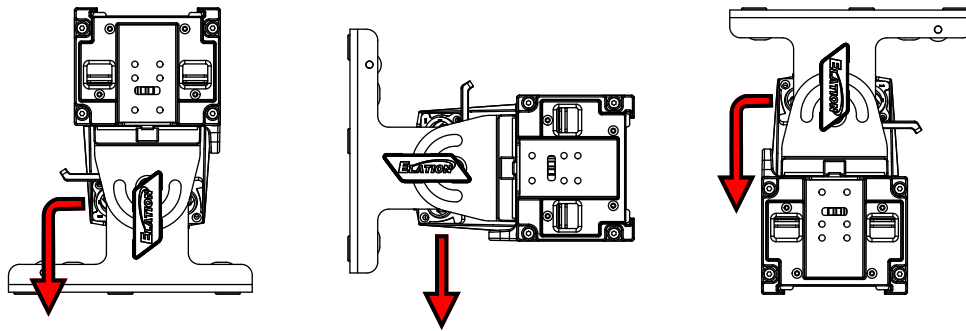

INSTALLATION GUIDELINES

POTENTIAL INTERNAL FIXTURE DAMAGE FROM EXTERNAL SOURCES OF LIGHT BEAMS

External sources of light beams from direct sunlight, lighting moving head fixtures, and lasers, which are focused directly towards the exterior housing and/or penetrate the front lens opening of ELATION lighting fixtures, can cause severe internal damage including burning to optics, dichroic color filters, glass and metal gobos, prisms, animation wheels, frost filters, iris, shutters, motors, belts, wiring, discharge lamps, and LEDs.

This issue is not specific only to ELATION lighting fixtures, it is a common issue with lighting fixtures from all manufacturers. Although there is no true way to fully prevent this issue from happening, the guidelines below can prevent any potential damage from occurring if followed. Contact ELATION Service for more details.

DO NOT EXPOSE THE FIXTURE AND/OR FRONT LENS OPENING TO LIGHT BEAMS FROM DIRECT SUNLIGHT, OTHER LIGHTING MOVING HEAD FIXTURES, AND LASERS WHILE UNPACKING, INSTALLATION, USE, AND EXTENDED IDLE TIMES OUTDOORS. DO NOT FOCUS A LIGHT BEAM FROM ONE LIGHTING FIXTURE DIRECTLY TOWARDS ANOTHER.

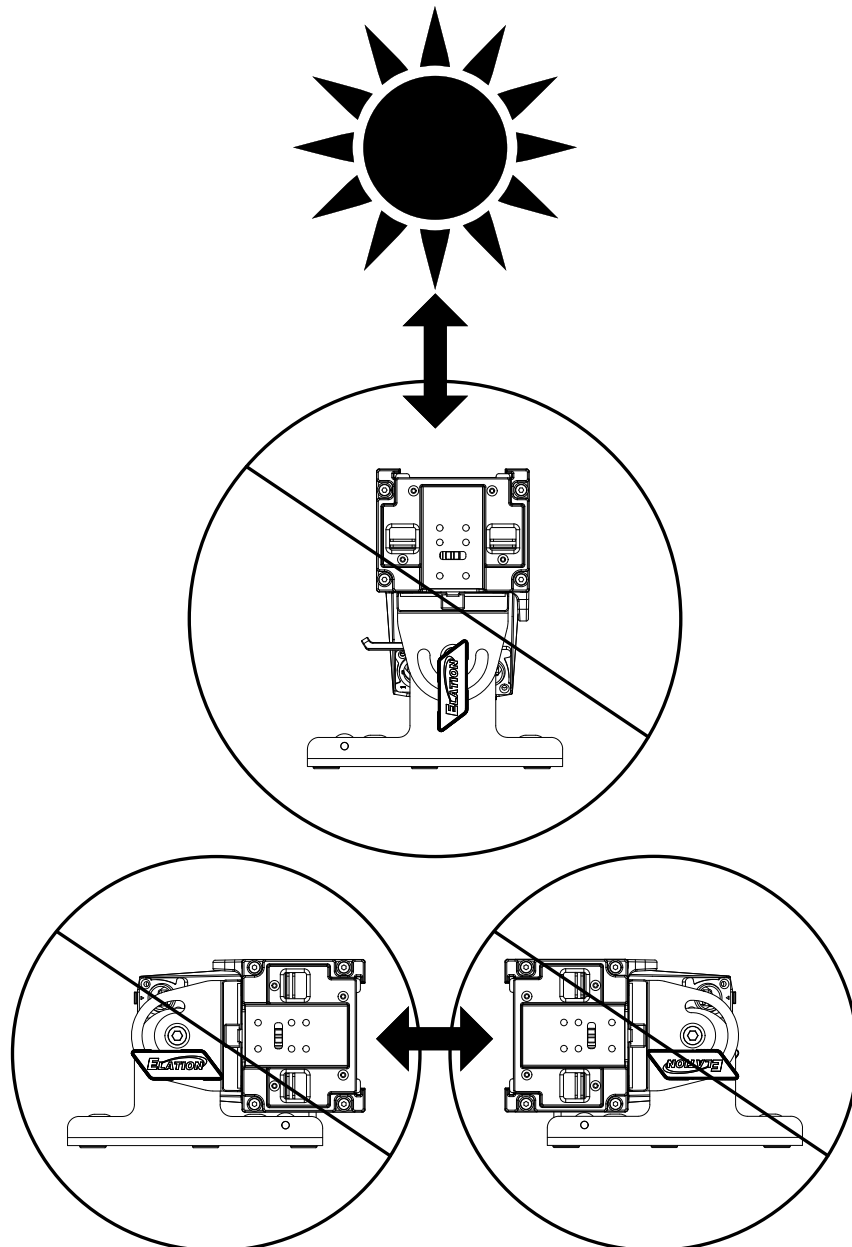

ACCESSORY INSTALLATION - FROST LENS

1. Slide lock levers downward to retract the locking tabs.

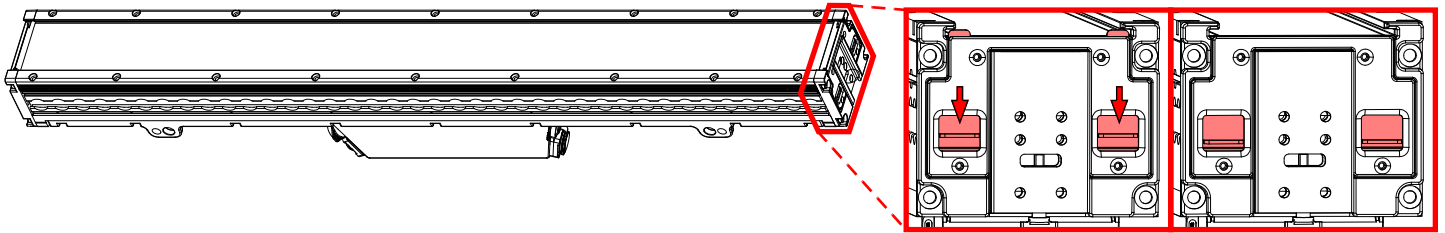

2. Install the Frost Lens by sliding it into the lens groove.

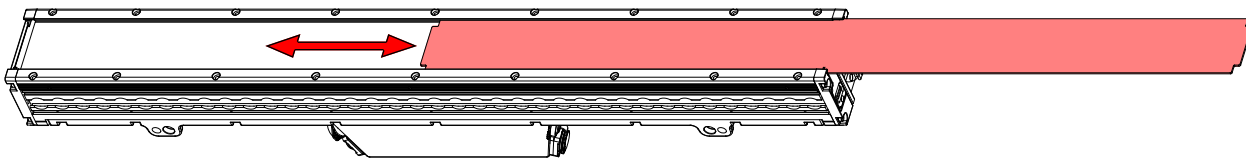

3. With the Frost Lens installed, slide levers upward to lock it in place.

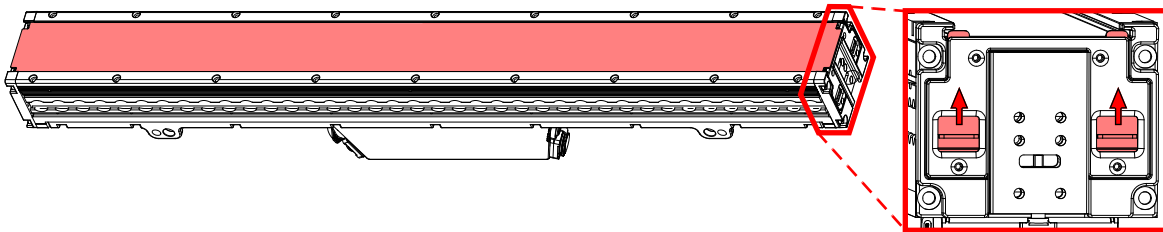

ACCESSORY INSTALLATION - GLARE SHIELD

1. Locate three Glare Shield mounting screw holes on side of fixture.

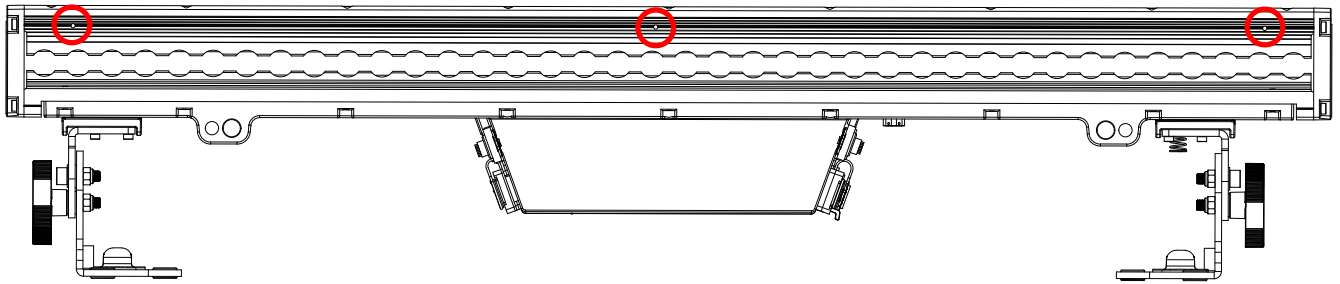

2. Align the thumbscrews of the Glare Shield with the mounting screw holes and insert them.

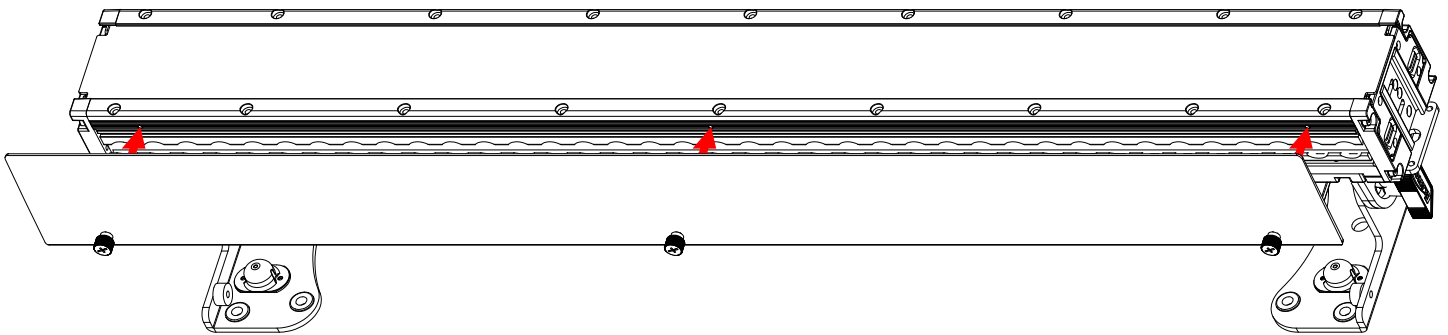

3. Tighten the two thumbscrews to secure Glare Shield. Thumbscrews can also be tightened with a Phillips screw driver.

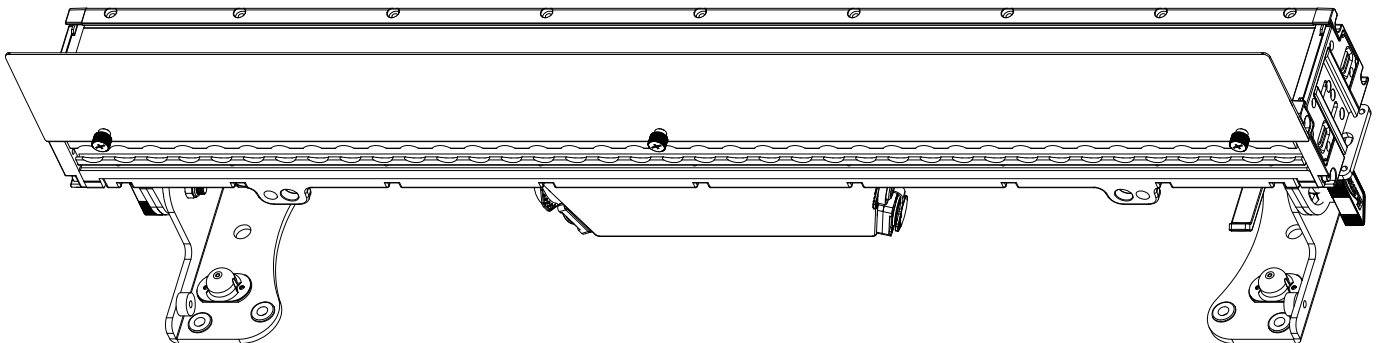

REMOTE DEVICE MANAGEMENT (RDM)

NOTE: In order for RDM to work properly, RDM enabled equipment must be used throughout the entire system, including DMX data splitters and wireless systems.

Remote Device Management (RDM) is a protocol that sits on top of the DMX512 data standard for lighting, and allows the DMX systems of the fixtures to be modified and monitored remotely. This protocol is ideal for instances in which a unit is installed in a location that is not easily accessible.

With RDM, the DMX512 system becomes bi-directional, allowing a compatible RDM enabled controller to send out a signal to devices on the wire, as well as allowing the fixture to respond (known as a GET command). The controller can then use its SET command to modify settings that would typically have to be changed or viewed directly via the unit's display screen, including the DMX Address, DMX Channel Mode, and Temperature Sensors.

FIXTURE RDM INFORMATION:

Device ID	Device Model ID	RDM Code	Personality ID
0x004A XXXX	0x004A	22A6	Dimmer 1CH RGB 3CH Color 6CH Color & Dimmer 9CH CMY 13CH CMY Extended 16CH Standard 16CH Extended 22CH 2 Cell Standard 22CH 2 Cell Extended 34CH 4 Cell Standard 44CH 4 Cell Extended 58CH 12 Cell Standard 82CH 12 Cell Extended 154CH Raw 12 Cell 72CH

Please be aware that **not all RDM devices support all RDM features**, and therefore it is important to check beforehand to ensure that the equipment that you are considering includes all of the features that you require.

The following parameters are accessible in RDM on this device:

[0x0001]	Discovery Unique Branch
[0x0050]	Supported Parameters
[0x0060]	Device Info
[0x0070]	Product Detail ID List
[0x0080]	Device Model Description
[0x0081]	Manufacturer Label
[0x0082]	Device Label
[0x00C0]	Software Version Label
[0x00E0]	DMX Personality
[0x00E1]	DMX Personality Description
[0x00F0]	DMX Start Address
[0x0200]	Sensor Definition
[0x0201]	Sensor Value
[0x0400]	Device Hours
[0x1000]	Identify Device

SYSTEM MENU

The fixture includes an easy to navigate system menu. The control panel display is located on the rear panel of the fixture (see image below) and provides access to the main system menu, where all necessary system adjustments are made to the fixture. During normal operation, pressing the **MODE** button once will access the fixture's main menu. Once in the main menu you can navigate through the different functions and access the sub-menus with the **DOWN** and **UP** buttons. Once you reach a field that requires adjusting, press the **ENTER** button to activate that field and use the **DOWN** and **UP** buttons to adjust the field. Pressing the **ENTER** button once more will confirm the setting. Exit the main menu at any time without making any adjustments by pressing the **MODE** button.

PERMANENT INSTALLATION SETTING AND PHANTOM TOUCH

A phantom touch on an LCD screen is an unexpected, unprompted touch that seems to occur without any physical contact, like a raindrop. When installing any fixture in a permanent setting, we recommend setting your display to lock after 10-seconds and not the **OFF** setting. Units in a permanent setting are exposed to various conditions, if a unit is set to **OFF**, the display may interpret a raindrop as a command and change the fixture's setting through a phantom touch. Setting the display to lock after 10-seconds, and not setting a the display to **OFF**, prevents this scenario.

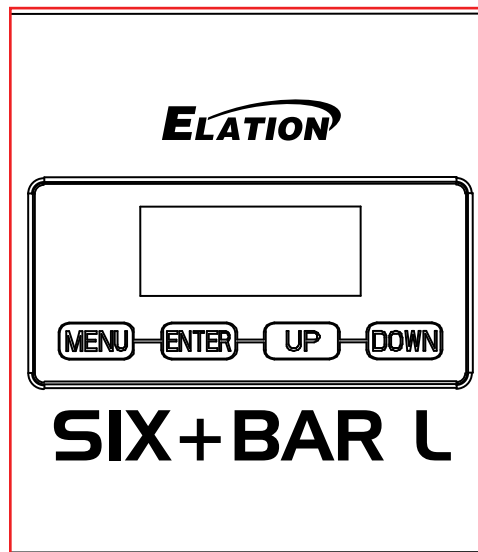

AN ELATION C-LOADER II CAN ALSO BE USED TO UPDATE THE FIXTURE TO THE LATEST SOFTWARE. To order this device, please contact Elation Support for further details.

Detailed instructions can be found online at www.elationlighting.com.

ELATION SERVICE USA - Monday - Friday 8:00am to 4:30pm PST
323-582-3322 | support@elationlighting.com

ELATION SERVICE EUROPE - Monday - Friday 08:30 to 17:00 CET
+31 45 546 85 63 | support@elationlighting.eu

SYSTEM MENU

MAIN MENU		OPTIONS / VALUES (Default Settings in BOLD)		
DMX	DMX Address	001 - 512		
	DMX Mode	1CH Dimmer		
		3CH RGB		
		6CH Color		
		9CH Color & Dimmer		
		13CH CMY		
		16CH CMY Extended		
		16CH Standard		
		22CH Extended		
		22CH 2 Cell Standard		
		34CH 2 Cell Extended		
		44CH 4 Cell Standard		
		58CH 4 Cell Extended		
		82CH 12 Cell Standard		
		154CH 12 Cell Extended		
72CH Raw 12 Cell				
	SixBar 1000 Emulation (See Emulated DMX Traits on page 34)	6 Channel	7 Channel	
		11 Channel	13 Channel	
		75 Channel		
No DMX Status	Hold Last , Fade to Black, Standalone			
Protocol	Select Signal	DMX / Art-Net / sACN / Klingnet /Aria In - DMX Out / DMX In - Aria Out		
	Universe	0- 255 (Default = 1)		
	IP Address	2.x.x.x		
	Subnet Mask	255.0.0.0		
	Ethernet DMX Out	Off / On		
Aria	Aria Channel	0 -14		
Control	Manual Control	Dimmer	000% - 100%	
		Red	0 - 255	
		Green	0 - 255	
		Blue	0 - 255	
		Lime	0 - 255	
		Amber	0 - 255	
		UV	0 - 255	
		CCT	2400K - 8500K (Default = 6000K).	
	Virtual Color	See Color Macros		
	Primary	On / Off		
Secondary	On / Off			
Self Test	All			
	Dimmer			
	Color			
Settings	Dim Modes	Standard , Stage, TV, Architectural, Theatre, Stage 2		
		Dim Speed	0s - 10s (Default = 0.1s)	
	Dim to Warm	On / Off		
	Dim Curves	Linear, Square, Square Inverse, S-Curve		
	LED Refresh Rate	900Hz - 1500Hz (1200 Hz), 2500Hz, 4000Hz, 5000Hz, 6000Hz, 10KHz, 15KHz, 20KHz, 25KHz		
	LED Power Limit	50%, 60%, 70%, 80%, 90%, 100%		
	Pixel Flip	Yes / No		
	Display	Screen Delay	10s - 5min (Default = 1 min)	
		Screen Lock	Off , 10s - 5 min, Key Lock	
Rotate Display		Yes / No / Auto		
Reset Defaults	Yes / No			

SYSTEM MENU

MAIN MENU	OPTIONS / VALUES (Default Settings in BOLD)		
Information	Time	Current Run Time	
		Total Run Time	
		Last Run Time	
	Temperature	Current	
		Max Resettable	
	Humidity	Current	
		Max Resettable	
	DMX Values	Red	
		Green	
		...	
Product IDs	RDM UID		
Error Logs	Fixture Errors		
Software Version	Vx.x		
Service (Passcode = 50)	Calibration	All Red 0 - 255	
		All Green 0 - 255	
		All Blue 0 - 255	
		All Lime 0 - 255	
		All Amber 0 - 255	
		All UV 0 - 255	
		Red 1 0 - 255	
		Green 1 0 - 255	
		Blue 1 0 - 255	
		Lime 1 0 - 255	
		Amber 1 0 - 255	
		UV 1 0 - 255	
		
		Red 12 0 - 255	
		Green 12 0 - 255	
		Blue 12 0 - 255	
		Lime 12 0 - 255	
		Amber 12 0 - 255	
		UV 12 0 - 255	
	Reset Last Run	Yes / No	
Reset Error Logs	Yes / No		

NOTE ON EMULATION DMX TRAITS (see page 34)

To ensure the SIX+ BAR L can be integrated seamlessly alongside original SixBar fixtures, great care has been taken to ensure that the new LED array colors match the original. A unique SixBar Emulation DMX mode has been developed, so that the new fixtures can be controlled with the same DMX mapping as the original. The color mixing has also been calibrated to virtually emulate the White LED included in the SixPar array and an output limit master setting has been added so your new lights don't overpower any older fixtures in the rig.

DIMMER MODES & CURVES

DIMMER

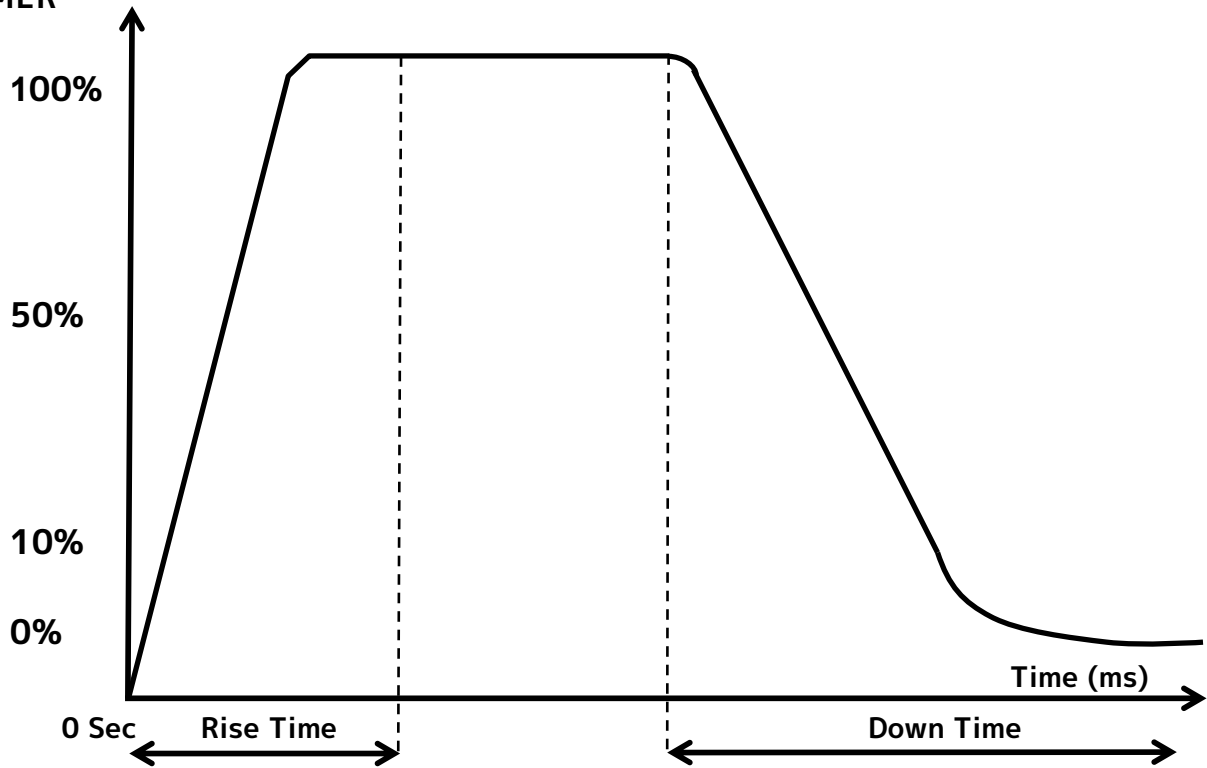

Dimming Curve Ramp Effect	0 sec Fade Time		1 sec Fade Time	
	Rise Time (ms)	Down Time (ms)	Rise Time (ms)	Down Time (ms)
Standard (default)	0	0	0	0
Stage	780	1100	1540	1660
TV	1180	1520	1860	1940
Architectural	1380	1730	2040	2120
Theatre	1580	1940	2230	2280
Stage 2	0	1100	0	1660

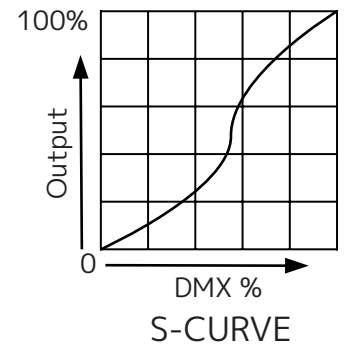
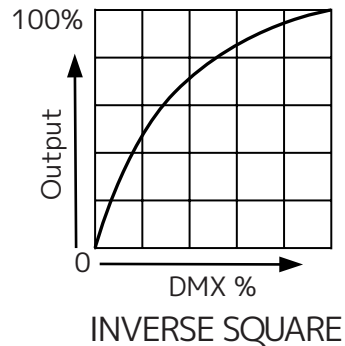
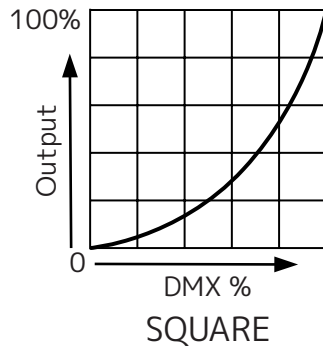
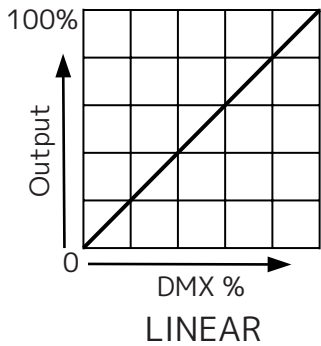

DMX TRAITS

Dimmer 1CH	RGB 3CH	Color 6CH	Color & Dimmer 9CH	DMX Values	Function	Snap	Default Value
1			1	0-255	Dimmer Intensity 0 → 100%		0
			2	0-255	Dimmer Fine Fine Intensity Control		0
			3		Shutter/Strobe	X	50
				0-31	Shutter closed		
				32-63	No function (shutter open)		
				64-95	Strobe effect slow to fast		
				96-127	No function (shutter open)		
				128-159	Pulse-effect in sequences		
				160-191	No function (shutter open)		
				192-223	Random strobe effect slow to fast		
			224-255	No function (shutter open)			
	1	1	4	0-255	Red Red Saturation 0 → 100%		0
	2	2	5	0-255	Green Green Saturation 0 → 100%		0
	3	3	6	0-255	Blue Blue Saturation 0 → 100%		0
		4	7	0-255	Lime Lime Saturation 0 → 100%		0
		5	8	0-255	Amber Amber Saturation 0 → 100%		0
		6	9	0-255	UV UV Saturation 0 → 100%		0

DMX TRAITS

CMY 13CH	CMY Ext 16CH	Std. 16CH	Ext. 22CH	2 Cell Std 22CH	2 Cell Ext 34CH	4 Cell Std 44CH	4 Cell Ext 58CH	12 Cell Std 82CH	12 Cell Ext 154CH	Raw 12 Cell 72CH	DMX Values	Function	Snap	Default Value	
1	1	1	1	1	1	1	1	1	1		0-255	Dimmer Intensity 0 → 100%		0	
2	2	2	2	2	2	2	2	2	2		0-255	Dimmer Fine Fine Intensity Control		0	
3	3	3	3	3	3	3	3	3	3			Shutter/Strobe	X	0	
												0-31			Shutter closed
												32-63			No function (shutter open)
												64-95			Strobe effect slow to fast
												96-127			No function (shutter open)
												128-159			Pulse-effect in sequences
												160-191			No function (shutter open)
												192-223			Random strobe effect slow to fast
224-255	No function (shutter open)														
		4	4	4	4	4	4	4	4	1	0-255	Red Red Saturation 0 → 100%		0	
			5		5		5		5		0-255	Red Fine Fine Red Control		0	
		5	6	5	6	5	6	5	6	2	0-255	Green Green Saturation 0 → 100%		0	
			7		7		7		7		0-255	Green Fine Fine Green Control		0	
		6	8	6	8	6	8	6	8	3	0-255	Blue Blue Saturation 0 → 100%		0	
			9		9		9		9		0-255	Blue Fine Fine Blue Control		0	
		7	10	7	10	7	10	4	10	4	0-255	Lime Lime Saturation 0 → 100%		0	
			11		11		11		11		0-255	Lime Fine Fine Lime Control		0	
		8	12	8	12	8	12	5	12	5	0-255	Amber Amber Saturation 0 → 100%		0	
			13		13		13		13		0-255	Amber Fine Fine Amber Control		0	
		9	14	9	14	9	14	9	14	6	0-255	UV UV Saturation 0 → 100%		0	
			15		15		15		15		0-255	UV Fine Fine UV Control		0	
				10	16	10	16	10	16	7	0-255	Red 2 Red Saturation 0 → 100%		0	
					17		17		17		0-255	Red Fine 2 Fine Red Control		0	
				11	18	11	18	11	18	8	0-255	Green 2 Green Saturation 0 → 100%		0	
					19		19		19		0-255	Green Fine 2 Fine Green Control		0	
				12	20	12	20	12	20	9	0-255	Blue 2 Blue Saturation 0 → 100%		0	
					21		21		21		0-255	Blue Fine 2 Fine Blue Control		0	
				13	22	13	22	13	22	10	0-255	Lime 2 Lime Saturation 0 → 100%		0	
					23		23		23		0-255	Lime Fine 2 Fine Lime Control		0	
				14	24	14	24	14	24	11	0-255	Amber 2 Amber Saturation 0 → 100%		0	
					25		25		25		0-255	Amber Fine 2 Fine Amber Control		0	
				15	26	15	26	15	26	12	0-255	UV 2 UV Saturation 0 → 100%		0	
					27		27		27		0-255	UV Fine 2 Fine UV Control		0	

DMX TRAITS

CMY 13CH	CMY Ext 16CH	Std. 16CH	Ext. 22CH	2 Cell Std 22CH	2 Cell Ext 34CH	4 Cell Std 44CH	4 Cell Ext 58CH	12 Cell Std 82CH	12 Cell Ext 154CH	Raw 12 Cell 72CH	DMX Values	Function	Snap	Default Value
						16	28	16	28	13	0-255	Red 3 Red Saturation 0 → 100%		0
							29		29		0-255	Red Fine 3 Fine Red Control		0
						17	30	17	30	14	0-255	Green 3 Green Saturation 0 → 100%		0
							31		31		0-255	Green Fine 3 Fine Green Control		0
						18	32	15	32	15	0-255	Blue 3 Blue Saturation 0 → 100%		0
							33		33		0-255	Blue Fine 3 Fine Blue Control		0
						19	34	16	34	16	0-255	Lime 3 Lime Saturation 0 → 100%		0
							35		35		0-255	Lime Fine 3 Fine Lime Control		0
						20	36	17	36	17	0-255	Amber 3 Amber Saturation 0 → 100%		0
							37		37		0-255	Amber Fine 3 Fine Amber Control		0
						21	38	18	38	18	0-255	UV 3 UV Saturation 0 → 100%		0
							39		39		0-255	UV Fine 3 Fine UV Control		0
						22	40	19	40	19	0-255	Red 4 Red Saturation 0 → 100%		0
							41		41		0-255	Red Fine 4 Fine Red Control		0
						23	42	20	42	20	0-255	Green 4 Green Saturation 0 → 100%		0
							43		43		0-255	Green Fine 4 Fine Green Control		0
						24	44	21	44	21	0-255	Blue 4 Blue Saturation 0 → 100%		0
							45		45		0-255	Blue Fine 4 Fine Blue Control		0
						25	46	22	46	22	0-255	Lime 4 Lime Saturation 0 → 100%		0
							47		47		0-255	Lime Fine 4 Fine Lime Control		0
						26	48	23	48	23	0-255	Amber 4 Amber Saturation 0 → 100%		0
							49		49		0-255	Amber Fine 4 Fine Amber Control		0
						27	50	24	50	24	0-255	UV 4 UV Saturation 0 → 100%		0
							51		51		0-255	UV Fine 4 Fine UV Control		0

DMX TRAITS

CMY 13CH	CMY Ext 16CH	Std. 16CH	Ext. 22CH	2 Cell Std 22CH	2 Cell Ext 34CH	4 Cell Std 44CH	4 Cell Ext 58CH	12 Cell Std 82CH	12 Cell Ext 154CH	Raw 12 Cell 72CH	DMX Values	Function	Snap	Default Value
								28	52	25	0-255	Red 5 Red Saturation 0 → 100%		0
									53		0-255	Red Fine 5 Fine Red Control		0
								29	54	26	0-255	Green 5 Green Saturation 0 → 100%		0
									55		0-255	Green Fine 5 Fine Green Control		0
								30	56	27	0-255	Blue 5 Blue Saturation 0 → 100%		0
									57		0-255	Blue Fine 5 Fine Blue Control		0
								31	58	28	0-255	Lime 5 Lime Saturation 0 → 100%		0
									59		0-255	Lime Fine 5 Fine Lime Control		0
								32	60	29	0-255	Amber 5 Amber Saturation 0 → 100%		0
									61		0-255	Amber Fine 5 Fine Amber Control		0
								33	62	30	0-255	UV 5 UV Saturation 0 → 100%		0
									63		0-255	UV Fine 5 Fine UV Control		0
								34	64	31	0-255	Red 6 Red Saturation 0 → 100%		0
									65		0-255	Red Fine 6 Fine Red Control		0
								35	66	32	0-255	Green 6 Green Saturation 0 → 100%		0
									67		0-255	Green Fine 6 Fine Green Control		0
								36	68	33	0-255	Blue 6 Blue Saturation 0 → 100%		0
									69		0-255	Blue Fine 6 Fine Blue Control		0
								37	70	34	0-255	Lime 6 Lime Saturation 0 → 100%		0
									71		0-255	Lime Fine 6 Fine Lime Control		0
								38	72	35	0-255	Amber 6 Amber Saturation 0 → 100%		0
									73		0-255	Amber Fine 6 Fine Amber Control		0
								39	74	36	0-255	UV 6 UV Saturation 0 → 100%		0
									75		0-255	UV Fine 6 Fine UV Control		0

DMX TRAITS

CMY 13CH	CMY Ext 16CH	Std. 16CH	Ext. 22CH	2 Cell Std 22CH	2 Cell Ext 34CH	4 Cell Std 44CH	4 Cell Ext 58CH	12 Cell Std 82CH	12 Cell Ext 154CH	Raw 12 Cell 72CH	DMX Values	Function	Snap	Default Value
								40	76	37	0-255	Red 7 Red Saturation 0 → 100%		0
									77		0-255	Red Fine 7 Fine Red Control		0
								41	78	38	0-255	Green 7 Green Saturation 0 → 100%		0
									79		0-255	Green Fine 7 Fine Green Control		0
								42	80	39	0-255	Blue 7 Blue Saturation 0 → 100%		0
									81		0-255	Blue Fine 7 Fine Blue Control		0
								43	82	40	0-255	Lime 7 Lime Saturation 0 → 100%		0
									83		0-255	Lime Fine 7 Fine Lime Control		0
								44	84	41	0-255	Amber 7 Amber Saturation 0 → 100%		0
									85		0-255	Amber Fine 7 Fine Amber Control		0
								45	86	42	0-255	UV 7 UV Saturation 0 → 100%		0
									87		0-255	UV Fine 7 Fine UV Control		0
								46	88	43	0-255	Red 8 Red Saturation 0 → 100%		0
									89		0-255	Red Fine 8 Fine Red Control		0
								47	90	44	0-255	Green 8 Green Saturation 0 → 100%		0
									91		0-255	Green Fine 8 Fine Green Control		0
								48	92	45	0-255	Blue 8 Blue Saturation 0 → 100%		0
									93		0-255	Blue Fine 8 Fine Blue Control		0
								49	94	46	0-255	Lime 8 Lime Saturation 0 → 100%		0
									95		0-255	Lime Fine 8 Fine Lime Control		0
								50	96	47	0-255	Amber 8 Amber Saturation 0 → 100%		0
									97		0-255	Amber Fine 8 Fine Amber Control		0
								51	98	48	0-255	UV 8 UV Saturation 0 → 100%		0
									99		0-255	UV Fine 8 Fine UV Control		0

DMX TRAITS

CMY 13CH	CMY Ext 16CH	Std. 16CH	Ext. 22CH	2 Cell Std 22CH	2 Cell Ext 34CH	4 Cell Std 44CH	4 Cell Ext 58CH	12 Cell Std 82CH	12 Cell Ext 154CH	Raw 12 Cell 72CH	DMX Values	Function	Snap	Default Value
								52	100	49	0-255	Red 9 Red Saturation 0 → 100%		0
									101		0-255	Red Fine 9 Fine Red Control		0
								53	102	50	0-255	Green 9 Green Saturation 0 → 100%		0
									103		0-255	Green Fine 9 Fine Green Control		0
								54	104	51	0-255	Blue 9 Blue Saturation 0 → 100%		0
									105		0-255	Blue Fine 9 Fine Blue Control		0
								55	106	52	0-255	Lime 9 Lime Saturation 0 → 100%		0
									107		0-255	Lime Fine 9 Fine Lime Control		0
								56	108	53	0-255	Amber 9 Amber Saturation 0 → 100%		0
									109		0-255	Amber Fine 9 Fine Amber Control		0
								57	110	54	0-255	UV 9 UV Saturation 0 → 100%		0
									111		0-255	UV Fine 9 Fine UV Control		0
								58	112	55	0-255	Red 10 Red Saturation 0 → 100%		0
									113		0-255	Red Fine 10 Fine Red Control		0
								59	114	56	0-255	Green 10 Green Saturation 0 → 100%		0
									115		0-255	Green Fine 10 Fine Green Control		0
								60	116	57	0-255	Blue 10 Blue Saturation 0 → 100%		0
									117		0-255	Blue Fine 10 Fine Blue Control		0
								61	118	58	0-255	Lime 10 Lime Saturation 0 → 100%		0
									119		0-255	Lime Fine 10 Fine Lime Control		0
								62	120	59	0-255	Amber 10 Amber Saturation 0 → 100%		0
									121		0-255	Amber Fine 10 Fine Amber Control		0
								63	122	60	0-255	UV 10 UV Saturation 0 → 100%		0
									123		0-255	UV Fine 10 Fine UV Control		0

DMX TRAITS

CMY 13CH	CMY Ext 16CH	Std. 16CH	Ext. 22CH	2 Cell Std 22CH	2 Cell Ext 34CH	4 Cell Std 44CH	4 Cell Ext 58CH	12 Cell Std 82CH	12 Cell Ext 154CH	Raw 12 Cell 72CH	DMX Values	Function	Snap	Default Value
								64	124	61	0-255	Red 11 Red Saturation 0 → 100%		0
									125		0-255	Red Fine 11 Fine Red Control		0
								65	126	62	0-255	Green 11 Green Saturation 0 → 100%		0
									127		0-255	Green Fine 11 Fine Green Control		0
								66	128	63	0-255	Blue 11 Blue Saturation 0 → 100%		0
									129		0-255	Blue Fine 11 Fine Blue Control		0
								67	130	64	0-255	Lime 11 Lime Saturation 0 → 100%		0
									131		0-255	Lime Fine 11 Fine Lime Control		0
								68	132	65	0-255	Amber 11 Amber Saturation 0 → 100%		0
									133		0-255	Amber Fine 11 Fine Amber Control		0
								69	134	66	0-255	UV 11 UV Saturation 0 → 100%		0
									135		0-255	UV Fine 11 Fine UV Control		0
								70	136	67	0-255	Red 12 Red Saturation 0 → 100%		0
									137		0-255	Red Fine 12 Fine Red Control		0
								71	138	68	0-255	Green 12 Green Saturation 0 → 100%		0
									139		0-255	Green Fine 12 Fine Green Control		0
								72	140	69	0-255	Blue 12 Blue Saturation 0 → 100%		0
									141		0-255	Blue Fine 12 Fine Blue Control		0
								73	142	70	0-255	Lime 12 Lime Saturation 0 → 100%		0
									143		0-255	Lime Fine 12 Fine Lime Control		0
								74	144	71	0-255	Amber 12 Amber Saturation 0 → 100%		0
									145		0-255	Amber Fine 12 Fine Amber Control		0
								75	146	72	0-255	UV 12 UV Saturation 0 → 100%		0
									147		0-255	UV Fine 12 Fine UV Control		0

DMX TRAITS

CMY 13CH	CMY Ext 16CH	Std. 16CH	Ext. 22CH	2 Cell Std 22CH	2 Cell Ext 34CH	4 Cell Std 44CH	4 Cell Ext 58CH	12 Cell Std 82CH	12 Cell Ext 154CH	Raw 12 Cell 72CH	DMX Values	Function	Snap	Default Value	
4	4										0-255	Cyan		0	
												Cyan Saturation 0 → 100%			
	5										0-255	Cyan Fine		0	
												Fine Cyan Control			
5	6										0-255	Magenta		0	
												Magenta Saturation 0 → 100%			
	7										0-255	Magenta Fine		0	
												Fine Magenta Control			
6	8										0-255	Yellow		0	
												Yellow Saturation 0 → 100%			
	9										0-255	Yellow Fine		0	
												Fine Yellow Control			
7	10	10	16	16	28	28	52	76	148			Variable CCT			
												0-23			Open
												24-85			2400K → 8500K (See Sheet)
												86-255			8500K
8	11	11	17	17	29	29	53	77	149			Color Wheel		0	
												0			Open
												1-179			Virtual Swatch Book (See Table)
															Color Scroll
												180-201			Clockwise Fast → Slow
												202-207			Stop
												208-229			Counter-clockwise Slow → Fast
												230-234			Open
															Random Slots
												235-239			Fast
240-244	Medium														
245-249	Slow														
250-255	Open														
9	12	12	18	18	30	30	54	78	150		0-255	Effect Selection FX Selection 1 → 255	X	0	
10	13	13	19	19	31	31	55	79	151			Effect Speed		0	
												0-126			Slow → Fast
												127-128			Stop
											129-255	Rev Fast → Slow			
11	14	14	20	20	32	32	56	80	152			Effect Offset		X	
												0			Idle
												1			Fixture Offset 10 Degrees
												2			Fixture Offset 20 Degrees
												3-34			Fixture Offset...
												35			Fixture Offset 350 Degrees
												36			Synchronized
												37-49			Random Fixture Offset
												50-59			Random Pixel Order
												60-69			Random Steps
												70-79			Idle
															Effect Fade
												80-89			Sinewave- Cross
												90-99			Sinewave- Full
												100-109			Sawtooth- Cross
												110-119			Sawtooth- Full
120-129	Ramp Up														
130-139	Ramp Down														
140-149	Steps														
150-255	Idle														

DMX TRAITS

CMY 13CH	CMY Ext 16CH	Std. 16CH	Ext. 22CH	2 Cell Std 22CH	2 Cell Ext 34CH	4 Cell Std 44CH	4 Cell Ext 58CH	12 Cell Std 82CH	12 Cell Ext 154CH	Raw 12 Cell 72CH	DMX Values	Function	Snap	Default Value
12	15	15	21	21	33	33	57	81	153			Dim Modes	X	0
											0-20	Standard		
											21-40	Stage		
											41-60	TV		
											61-80	Architectural		
											81-100	Theatre		
											101-120	Stage 2		
												Dimmer Delay Time		
											121	0s		
											122	0.1s		
											123	0.2s		
											124	0.3s		
											125	0.4s		
											126	0.5s		
											127	0.6s		
											128	0.7s		
											129	0.8s		
											130	0.9s		
											131	1.0s		
											132	1.5s		
											133	2.0s		
											134	3.0s		
											135	4.0s		
											136	5.0s		
											137	6.0s		
											138	7.0s		
											139	8.0s		
140	9.0s													
141	10s													
142-255	Idle													
	Dim to Warm													
150-154	DTW On													
155-159	DTW Off													
160-255	Idle													
13	16	16	22	22	34	34	58	82	154			Control		
											0-59	Idle		
											60-69	Flip Pixel Order		
											70-79	Default Pixel Order		
											80-99	Idle		
												Refresh Rate (Hz)		
											100	900		
											101	910		
											102	920		
											103	930		
											104	940		
											105	950		
											106	960		
											107	970		
											108	980		
											109	990		
											110	1000		

DMX TRAITS

CMY 13CH	CMY Ext 16CH	Std. 16CH	Ext. 22CH	2 Cell Std 22CH	2 Cell Ext 34CH	4 Cell Std 44CH	4 Cell Ext 58CH	12 Cell Std 82CH	12 Cell Ext 154CH	Raw 12 Cell 72CH	DMX Values	Function	Snap	Default Value
											111	1010		
											112	1020		
											113	1030		
											114	1040		
											115	1050		
											116	1060		
											117	1070		
											118	1080		
											119	1090		
											120	1100		
											121	1110		
											122	1120		
											123	1130		
											124	1140		
											125	1150		
											126	1160		
											127	1170		
											128	1180		
											129	1190		
											130	1200		
											131	1210		
											132	1220		
											133	1230		
											134	1240		
											135	1250		
											136	1260		
											137	1270		
											138	1280		
											139	1290		
											140	1300		
											141	1310		
											142	1320		
13	16	16	22	22	34	34	58	82	154		143	1330	X	0
											144	1340		
											145	1350		
											146	1360		
											147	1370		
											148	1380		
											149	1390		
											150	1400		
											151	1410		
											152	1420		
											153	1430		
											154	1440		
											155	1450		
											156	1460		
											157	1470		
											158	1480		
											159	1490		
											160	1500		
											161	2500		
											162	4000		
											163	5000		
											164	6000		
											165	10000		
											166	15000		
											167	20000		
											168	25000		
											169-200	Idle		
												Dimmer Curves		
											201-210	Dimmer Curve: Linear (Default)		
											211-220	Dimmer Curve: Square		
											221-230	Dimmer Curve: Inverse Square		
											231-240	Dimmer Curve: S-Curve		
											241-255	Idle		

EMULATION DMX TRAITS FOR SIXBAR 1000

6CH	7CH	11CH	13CH	75CH	DMX Values	Function	Snap	Default Value
1	1	1	1	1	0-255	Red Red Saturation 0 → 100%		0
2	2	2	2	2	0-255	Green Green Saturation 0 → 100%		0
3	3	3	3	3	0-255	Blue Blue Saturation 0 → 100%		0
4	4	4	4	4	0-255	White White Saturation 0 → 100%		0
5	5	5	5	5	0-255	Amber Amber Saturation 0 → 100%		0
6	6	6	6	6	0-255	UV UV Saturation 0 → 100%		0
				7	0-255	Red 2 Red Saturation 0 → 100%		0
				8	0-255	Green 2 Green Saturation 0 → 100%		0
				9	0-255	Blue 2 Blue Saturation 0 → 100%		0
				10	0-255	White 2 White Saturation 0 → 100%		0
				11	0-255	Amber 2 Amber Saturation 0 → 100%		0
				12	0-255	UV 2 UV Saturation 0 → 100%		0
				13	0-255	Red 3 Red Saturation 0 → 100%		0
				14	0-255	Green 3 Green Saturation 0 → 100%		0
				15	0-255	Blue 3 Blue Saturation 0 → 100%		0
				16	0-255	White 3 White Saturation 0 → 100%		0
				17	0-255	Amber 3 Amber Saturation 0 → 100%		0
				18	0-255	UV 3 UV Saturation 0 → 100%		0
				19	0-255	Red 4 Red Saturation 0 → 100%		0
				20	0-255	Green 4 Green Saturation 0 → 100%		0
				21	0-255	Blue 4 Blue Saturation 0 → 100%		0
				22	0-255	White 4 White Saturation 0 → 100%		0
				23	0-255	Amber 4 Amber Saturation 0 → 100%		0
				24	0-255	UV 4 UV Saturation 0 → 100%		0
				25	0-255	Red 5 Red Saturation 0 → 100%		0
				26	0-255	Green 5 Green Saturation 0 → 100%		0
				27	0-255	Blue 5 Blue Saturation 0 → 100%		0
				28	0-255	White 5 White Saturation 0 → 100%		0
				29	0-255	Amber 5 Amber Saturation 0 → 100%		0
				30	0-255	UV 5 UV Saturation 0 → 100%		0

EMULATION DMX TRAITS FOR SIXBAR 1000

6CH	7CH	11CH	13CH	75CH	DMX Values	Function	Snap	Default Value
				31	0-255	Red 6 Red Saturation 0 → 100%		0
				32	0-255	Green 6 Green Saturation 0 → 100%		0
				33	0-255	Blue 6 Blue Saturation 0 → 100%		0
				34	0-255	White 6 White Saturation 0 → 100%		0
				35	0-255	Amber 6 Amber Saturation 0 → 100%		0
				36	0-255	UV 6 UV Saturation 0 → 100%		0
				37	0-255	Red 7 Red Saturation 0 → 100%		0
				38	0-255	Green 7 Green Saturation 0 → 100%		0
				39	0-255	Blue 7 Blue Saturation 0 → 100%		0
				40	0-255	White 7 White Saturation 0 → 100%		0
				41	0-255	Amber 7 Amber Saturation 0 → 100%		0
				42	0-255	UV 7 UV Saturation 0 → 100%		0
				43	0-255	Red 8 Red Saturation 0 → 100%		0
				44	0-255	Green 8 Green Saturation 0 → 100%		0
				45	0-255	Blue 8 Blue Saturation 0 → 100%		0
				46	0-255	White 8 White Saturation 0 → 100%		0
				47	0-255	Amber 8 Amber Saturation 0 → 100%		0
				48	0-255	UV 8 UV Saturation 0 → 100%		0
				49	0-255	Red 9 Red Saturation 0 → 100%		0
				50	0-255	Green 9 Green Saturation 0 → 100%		0
				51	0-255	Blue 9 Blue Saturation 0 → 100%		0
				52	0-255	White 9 White Saturation 0 → 100%		0
				53	0-255	Amber 9 Amber Saturation 0 → 100%		0
				54	0-255	UV 9 UV Saturation 0 → 100%		0
				55	0-255	Red 10 Red Saturation 0 → 100%		0
				56	0-255	Green 10 Green Saturation 0 → 100%		0
				57	0-255	Blue 10 Blue Saturation 0 → 100%		0
				58	0-255	White 10 White Saturation 0 → 100%		0
				59	0-255	Amber 10 Amber Saturation 0 → 100%		0
				60	0-255	UV 10 UV Saturation 0 → 100%		0

EMULATION DMX TRAITS FOR SIXBAR 1000

6CH	7CH	11CH	13CH	75CH	DMX Values	Function	Snap	Default Value
				61	0-255	Red 11 Red Saturation 0 → 100%		0
				62	0-255	Green 11 Green Saturation 0 → 100%		0
				63	0-255	Blue 11 Blue Saturation 0 → 100%		0
				64	0-255	White 11 White Saturation 0 → 100%		0
				65	0-255	Amber 11 Amber Saturation 0 → 100%		0
				66	0-255	UV 11 UV Saturation 0 → 100%		0
				67	0-255	Red 12 Red Saturation 0 → 100%		0
				68	0-255	Green 12 Green Saturation 0 → 100%		0
				69	0-255	Blue 12 Blue Saturation 0 → 100%		0
				70	0-255	White 12 White Saturation 0 → 100%		0
				71	0-255	Amber 12 Amber Saturation 0 → 100%		0
				72	0-255	UV 12 UV Saturation 0 → 100%		0
	7	7	7	73	0-255	Dimmer Intensity 0 → 100%		0
						Shutter/Strobe		
					0-31	Shutter closed		
					32-63	No function (shutter open)		
					64-95	Strobe effect slow to fast		
		8	8	74	96-127	No function (shutter open)	X	50
					128-159	Pulse-effect in sequences		
					160-191	No function (shutter open)		
					192-223	Random strobe effect slow to fast		
					224-255	No function (shutter open)		
						Color Macros		
					0-3	OFF		
					4-7	RED		
					8-11	GREEN		
					12-15	BLUE		
					16-19	WHITE		
					20-23	AMBER		
					24-27	UV		
					28-31	RED + GREEN		
					32-35	RED + BLUE		
					36-39	RED + WHITE		
					40-43	RED + AMBER		
					44-47	RED + UV		
					48-51	GREEN + BLUE		
					52-55	GREEN + WHITE		
					56-59	GREEN + AMBER		
					60-63	GREEN + UV		
					64-67	BLUE + WHITE		
					68-71	BLUE + AMBER		
					72-75	BLUE + UV		
					76-79	WHITE + AMBER		
					80-83	WHITE + UV		
					84-87	AMBER + UV		
					88-91	RED + GREEN + BLUE		
					92-95	RED + GREEN + WHITE		
					96-99	RED + GREEN + AMBER		
					100-103	RED + GREEN + UV		
					104-107	RED + BLUE + WHITE		
					108-111	RED + BLUE + AMBER		
					112-115	RED + BLUE + UV		
					116-119	RED + WHITE + AMBER		
					120-123	RED + WHITE + UV		
					124-127	RED + AMBER + UV		

PIXEL GROUPING & FLIP DIAGRAM

Pixel Grouping - Flip Off

12 Pixel Grouping

1	2	3	4	5	6	7	8	9	10	11	12
---	---	---	---	---	---	---	---	---	----	----	----

4 Pixel Grouping

1	2	3	4
---	---	---	---

2 Pixel Grouping

1	2
---	---

Pixel Grouping - Flip On

12 Pixel Grouping

12	11	10	9	8	7	6	5	4	3	2	1
----	----	----	---	---	---	---	---	---	---	---	---

4 Pixel Grouping

4	3	2	1
---	---	---	---

2 Pixel Grouping

2	1
---	---

COLOR TEMPERATURE

DMX VALUE	COLOR TEMPERATURE (K)	DMX VALUE	COLOR TEMPERATURE (K)
24	2400	63	6300
25	2500	64	6400
26	2600	65	6500
27	2700	66	6600
28	2800	67	6700
29	2900	68	6800
30	3000	69	6900
31	3100	70	7000
32	3200	71	7100
33	3300	72	7200
34	3400	73	7300
35	3500	74	7400
36	3600	75	7500
37	3700	76	7600
38	3800	77	7700
39	3900	78	7800
40	4000	79	7900
41	4100	80	8000
42	4200	81	8100
43	4300	82	8200
44	4400	83	8300
45	4500	84	8400
46	4600	85	8500
47	4700		
48	4800		
49	4900		
50	5000		
51	5100		
52	5200		
53	5300		
54	5400		
55	5500		
56	5600		
57	5700		
58	5800		
59	5900		
60	6000		
61	6100		
62	6200		

VIRTUAL COLORS

VALUE	FILTER #	COLOR	VALUE	FILTER #	COLOR
1	7	Pale Yellow	31	126	Mauve
2	103	Straw	32	49	Medium Purple
3	151	Gold Tint	33	58	Lavender
4	100	Spring Yellow	34	199	Palace Blue
5	10	Medium Yellow	35	119	Dark Blue
6	101	Yellow	36	132	Medium Blue
7	104	Deep Amber	37	120	Deep Blue
8	15	Deep Straw	38	165	Daylight Blue
9	179	Loving Amber	39	161	Slate Blue
10	21	Gold Amber	40	118	Light Blue
11	105	Orange	41	68	Sky Blue
12	158	Deep Orange	42	143	Pale Navy Blue
13	22	Dark Amber	43	131	Marine Blue
14	778	Millennium Gold	44	115	Peacock Blue
15	135	Deep Golden Amber	45	172	Lagoon Blue
16	24	Scarlet	46	116	Medium Blue Green
17	106	Primary Red	47	90	Dark Yellow Green
18	26	Bright Red	48	139	Primary Green
19	27	Medium Red	49	122	Fern Green
20	19	Fire	50	89	Moss Green
21	157	Pink	51	124	Dark Green
22	36	Medium Pink	52	88	Lime Green
23	111	Dark Pink	53	138	Pale Green
24	128	Bright Pink	54	203	Quarter CT Blue
25	148	Bright Rose	55	202	Half CT Blue
26	332	Special Rose Pink	56	201	FULL CT Blue
27	793	Vanity Fair	57	200	Double CT Blue
28	113	Magenta	58	206	Quarter CT Orange
29	46	Dark Magenta	59	205	Half CT Orange
30	48	Rose Purple	60	204	FULL CT Orange

ERROR CODES

Error Codes subject to change without notice	
ERROR CODES	DESCRIPTION
Temp Error	This message appears when there is a heating error.

MAINTENANCE GUIDELINES



DISCONNECT POWER BEFORE PERFORMING ANY MAINTENANCE!

CLEANING

Frequent cleaning is recommended to ensure proper function, optimized light output, and an extended life. The frequency of cleaning depends on the environment in which the fixture operates: damp, smoky or particularly dirty environments can cause greater accumulation of dirt on the fixture's optics. Clean periodically with a soft cloth to avoid dirt/debris accumulation.

NEVER use alcohol, solvents, or ammonia-based cleaners.

MAINTENANCE

Regular inspections are recommended to insure proper function and extended life. There are no user serviceable parts inside this fixture. Please refer all other service issues to an authorized Elation service technician. Should you need any spare parts, please order genuine parts from an authorized Elation dealer.

Please refer to the following points during routine inspections:

- A detailed electrical check by an approved electrical engineer every three months, to make sure the circuit contacts are in good condition and prevent overheating.
- Be sure all screws and fasteners are securely tightened at all times. Loose screws may fall out during normal operation, resulting in damage or injury as larger parts could fall.
- Check for any deformations on the housing, color lenses, rigging hardware and rigging points (ceiling, suspension, trussing). Deformations in the housing could allow for dust to enter into the fixture. Damaged rigging points or unsecured rigging could cause the fixture to fall and seriously injure a person(s).
- Electric power supply cables must not show any damage, material fatigue or sediments.

SPECIFICATIONS

SOURCE

(12) x 20W RGBLA+ UV LEDs
30,000 Hour Average LED Life*

*May vary depending on several factors including but not limited to: Environmental Conditions, Power/Voltage, Usage Patterns (On-Off Cycling), Control and Dimming.

PHOTOMETRIC DATA

Total Lumen Output:
9,325 (Integrating Sphere)
7,554 (Goniometer)
CRI- 92.3
TLCI- 83
No Lens
Beam Angle: 20°
Field Angle: 36°
Included Frost
Beam Angle: 32°
Field Angle: 60°

EFFECTS

Full Pixel Control
Electronic Dimmer and Strobe
Variable 16-bit Dimming Modes and Curves

COLOR

RGBLA+ UV Color Array
CMY Emulation
Dim-to-Warm Fade
Variable CCT 2400K - 8500K
Virtual Gel Swatch Book

CONTROL / CONNECTIONS

15 DMX Channel Modes (1ch, 3ch, 6ch, 9ch, 13ch, 16ch, 16ch, 22ch, 22ch, 34ch, 44ch, 58ch, 82ch, 154ch, 72ch)
5 Six Bar 1000 Emulation DMX Channel Modes (6ch, 7ch, 11ch, 13ch, 75ch)
4 Button Control Panel, LED Display
DMX, RDM, Art-NET, sACN Protocol Support
Aria x2 Wireless Device Management
RDM (Remote Device Management)
IP65 RJ45 Ethernet In/Out (Art-Net, sACN, KlingNet)
IP65 5pin XLR DMX In/Out
IP65 Locking Power Cable In/Out

SIZE / WEIGHT

Length: 39.4" (1000mm)
Width: 6.9" (175.5mm)
Vertical Height: 8.1" (206.4mm)
Weight: 24 lbs / 10.9kg

ELECTRICAL / THERMAL

AC 100-240V - 50/60Hz
210W Max Power Consumption
Power Thru Capacity: @110V: 7 Units; @240V: 16 Units
5°F to 113°F (-15°C to 45°C)
BTU/hr (+/- 10%) 716.1

INCLUDED ITEMS

Safety Cable
IP65 Locking Power Cable
Frost Filter
Glare Shield
Fixture Interconnect Splice

OPTIONAL ITEMS

BAR L NSP Lens (BLL021)
BAR L WFL Lens (BLL061)
BAR L XFL Lens (BLL101)
BAR L L140 Lens (BLL141)
BAR L L1060 Lens (BLL161)
BAR L Dome Frost Lens (BLL181)
BAR L Black Lens (BLL125)
8050000053 - Omega Bracket (Qty.2)
Fixture Interconnect Splice Package (FISP06)
L-Track to M10 Adapter, 70mm (LTR001)
L-Track to M10 Adapter, 44.5mm (LTR008)
L Track C-Clamp & Adapter Assembly, 70mm (LTR100)
L Track C-Clamp & Adapter Assembly, 44.5mm (LTR112)
Interconnect Clamp Adapter (FICA01)

APPROVALS / RATINGS

CE | cETLus | IP65 | FCC | UKCA

DIMENSION DRAWINGS

Drawings not to scale

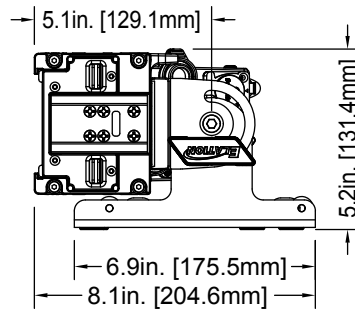
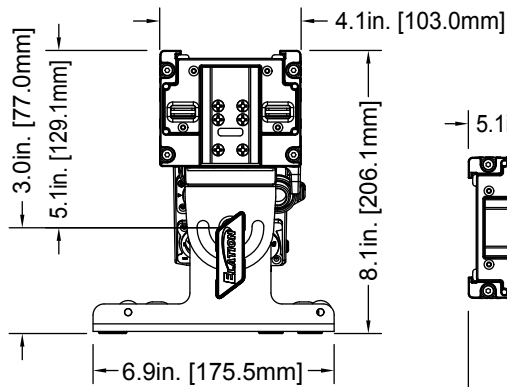
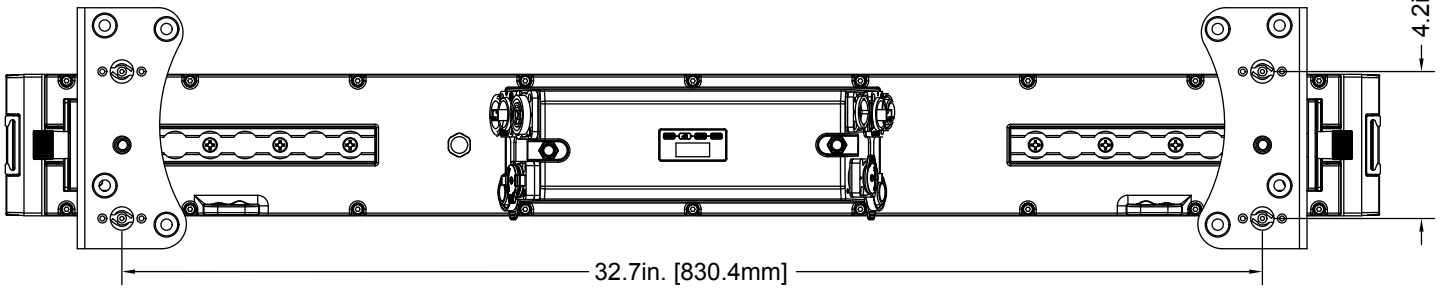
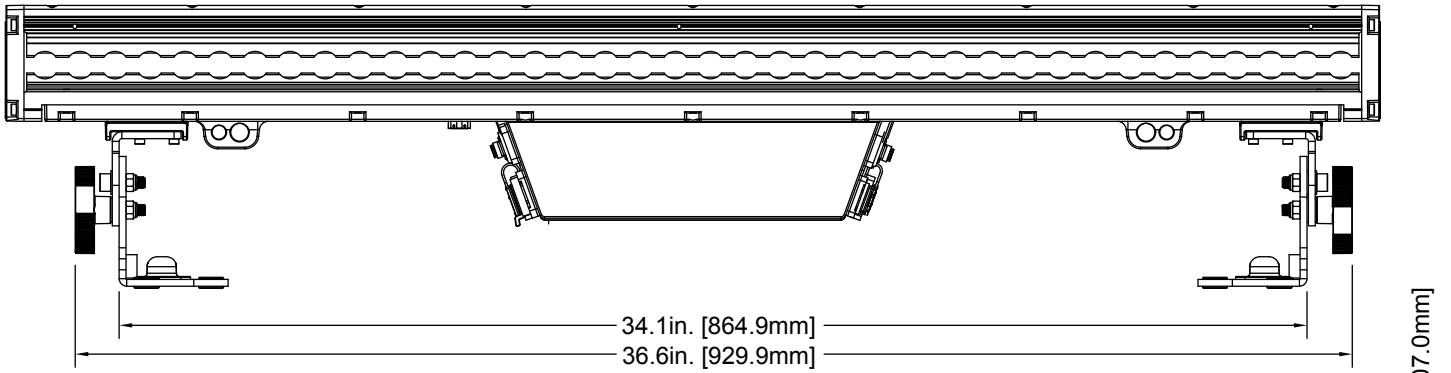
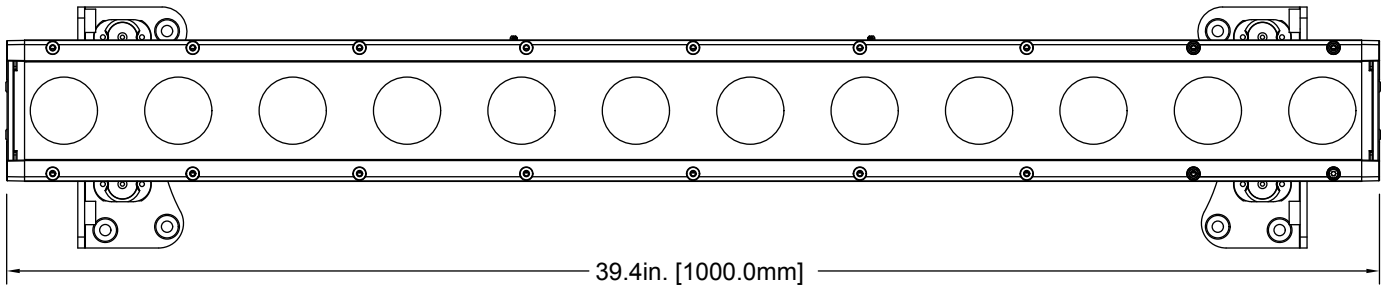

ORDERING INFORMATION

SKU US/EU		ITEM DESCRIPTION
SIX238	1237000342	SIX+ BAR L
BLL021	1223200113	BAR L NSP
BLL101	1223200111	BAR L XFL
BLL141	1223200110	BAR L L140
BLL161	1223200109	BAR L L1060
SPHDY	1236300112	SÖL/PULSE HD YOKE
FISP06	1236300110	Fixture Interconnect Splice Package
LTR001	N/A	L-Track to M10 Adapter, 70mm
LTR008	N/A	L-Track to M10 Adapter, 44.5mm
LTR100	N/A	L-Track C-Clamp & Adapter Assembly 70mm
LTR112	N/A	L-Track C-Clamp & Adapter Assembly 44.5mm
TRIGGER CLAMP	N/A	Heavy Duty Wrap Around Hook Style Clamp
STR527	N/A	5 ft. (1.5m) IP65 5pin XLR Cable

FCC STATEMENT

This device complies with Part 15 of the FCC Rules. Operation is subject to the following two conditions: (1) this device may not cause harmful interference, and (2) this device must accept any interference received, including interference that may cause undesired operation.

FCC RADIO FREQUENCY INTERFERENCE WARNINGS & INSTRUCTIONS

This product has been tested and found to comply with the limits as per Part 15 of the FCC Rules. These limits are designed to provide reasonable protection against harmful interference in a residential installation. This device uses and can radiate radio frequency energy and, if not installed and used in accordance with the included instructions, may cause harmful interference to radio communications. However, there is no guarantee that interference will not occur in a particular installation. If this device does cause harmful interference to radio or television reception, which can be determined by turning the device off and on, the user is encouraged to try to correct the interference by one or more of the following methods:

- Reorient or relocate the device.
- Increase the separation between the device and the receiver.
- Connect the device to an electrical outlet on a circuit different from which the radio receiver is connected.
- Consult the dealer or an experienced radio/TV technician for help.

Energy Saving Matters (EuP 2009/125/EC)

Saving electric energy is a key to help protecting the environment. Please turn off all electrical products when they are not in use. To avoid power consumption in idle mode, disconnect all electrical equipment from power when not in use. Thank you!



INDEX

- AC power, 45
- Accessory installation, 19–20
- Adjustable Trunnion, 8, 9
- Air valve, 8, 10
- Ambient temperature, 6, 11, 45
- Aria x2, 23, 45
- Art-Net, 17, 23, 45

- Beam angle, 45
- Box contents, 4
- BTU/hr, 45

- Calibration, 24
- CCT, 23, 33, 41, 45
- Cleaning, 44
- CMY emulation, 24, 33, 45
- Color macros, 38–39
- Color temperature, 41
- Control panel, 22, 45
- Customer support, 4, 22

- Dimmer curves, 25, 35, 45
- Dimmer modes, 23, 25, 34, 39
- Dimension drawings, 46
- Dim-to-Warm, 23, 34, 45
- Display settings, 22–23
- DMX address, 21, 23
- DMX channel modes, 21, 23, 45
- DMX traits, 26–35

- Electrical connections, 11
- Ethernet, 17, 23, 45

- FCC statement, 47
- Field angle, 45
- Fixture interconnect, 8, 15, 45, 47
- Frost filter / frost lens, 4, 19, 45

- Glare shield, 4, 20, 45

- Humidity, 24

- IGMP, 17
- Included items, 45
- IP65 rating, 5, 10, 17, 45
- IP test parameters, 10

- KlingNet, 23, 45

- LED refresh rate, 23, 34–35
- L-Track, 8, 9, 13, 16, 45, 47

- Maintenance, 5, 44
- Maritime / seaside environments, 5
- Mounting clamps, 12–13

- No DMX status, 23

- Omega brackets, 12, 45
- Optional items, 45
- Ordering information, 47

- Photometric data, 45
- Pixel flip / grouping, 23, 40
- Power and data cables, 17
- Power thru capacity, 45

- RDM, 21, 45
- Rigging limits, 16

- sACN, 17, 23, 45
- Safety cable, 4, 8, 12, 14, 45
- Service menu, 24
- Shutter / strobe, 26–27, 38, 45
- SixBar 1000 emulation, 23–24, 36–39, 45
- Specifications, 45
- System menu, 22–24

- Temperature Error, 43
- Temperature sensors, 21, 24
- Torque settings, 9

- UV radiation, 7

- Virtual colors, 23, 33, 42, 45

- Warranty information, 4

