

**ELATION<sup>®</sup>**

**DMX 101**

**A DMX 512 HANDBOOK**

©2020 **ELATION PROFESSIONAL** all rights reserved. Information, specifications, diagrams, images, and instructions herein are subject to change without notice. ELATION PROFESSIONAL logo and identifying product names and numbers herein are trademarks of ELATION PROFESSIONAL. Copyright protection claimed includes all forms and matters of copyrightable materials and information now allowed by statutory or judicial law or hereinafter granted. Product names used in this document may be trademarks or registered trademarks of their respective companies and are hereby acknowledged. All non-ELATION brands and product names are trademarks or registered trademarks of their respective companies.

**ELATION PROFESSIONAL** and all affiliated companies hereby disclaim any and all liabilities for property, equipment, building, and electrical damages, injuries to any persons, and direct or indirect economic loss associated with the use or reliance of any information contained within this document, and/or as a result of the improper, unsafe, insufficient and negligent assembly, installation, rigging, and operation of this product.

**Elation Professional USA** | 6122 S. Eastern Ave. | Los Angeles, CA. 90040  
323-582-3322 | 323-832-9142 fax | [www.elationlighting.com](http://www.elationlighting.com) | [info@elationlighting.com](mailto:info@elationlighting.com)

**Elation Professional B.V.** | Junostraat 2 | 6468 EW Kerkrade, The Netherlands  
+31 45 546 85 66 | +31 45 546 85 96 fax | [www.elationlighting.eu](http://www.elationlighting.eu) | [info@elationlighting.eu](mailto:info@elationlighting.eu)

**Elation Professional Mexico** | AV Santa Ana 30 | Parque Industrial Lerma, Lerma, Mexico 52000  
+52 (728) 282-7070

## DOCUMENT VERSION



**An updated version of this document may be available online. Please scan the QR Code with your mobile device or visit [www.elationlighting.com](http://www.elationlighting.com) for the latest revision/update of this manual.**

<b>Date</b>	<b>Document Version</b>	<b>Notes</b>
1/22/20	2.0	Updated release

# Table of Contents

1. Introduction to DMX	4
2. Industry Standards	5
2.1 USITT	5
2.2 ESTA	5
2.3 ANSI	6
2.4 EIZ/TIA	6
2.5 References	6
3. Theory of Operation	7
3.1 The Cable TV Analogy	7
3.2 DMX Communications	10
3.3 Summary	12
4. Protocol Specifications	13
4.1 Connectors	13
4.2 Cabling	14
4.3 Data	15
5. Sample Applications	16
5.1 Dimmer Control	17
5.2 Intelligent Fixture Control	18
5.3 Intelligent Fixture Control	19
5.4 Distributed Control	20

# 1. Introduction to DMX

Often those of us plunged into the entertainment lighting industry, through work or circumstance, find ourselves inundated with industry jargon and information overload. What is a moving head fixture, and how do you control it? What is this DMX I keep hearing about? This handbook is designed to promote a basic understanding of the DMX 512 protocol. With this in mind, it covers the basics in theory of operation, proper equipment use, and some very basic sample applications.

DMX 512 is a communication protocol, a set of rules, that are used to remotely control lighting-dimmers and intelligent-fixtures through a communication standard, a common way of communicating to these lighting devices regardless of the manufacturer. DMX is the acronym for **D**igital **M**ultiple**X**, and **512** is the available number of control slots, or channels, for transmission. The **512** channels comprise a DMX 'universe'. In a simple dimming system, one channel controls the intensity of one dimmer. A single intelligent fixture, however, may require several channels to control its various parameters (one channel each for pan, tilt, color, gobo, etc.), and in many cases, functions or colors are controlled within a given value range on a single channel as seen with the COLOR WHEEL on the sample chart below (especially in the EXTENDED column). A basic dimming control console may support only a few of the 512 available channels, whereas many professional control consoles can support multiple universes, allowing for thousands of control channels.



Sample channel list of a basic dimming control console with 10 channels, where each dimmer slide controls a specific feature:

1. Pan
2. Tilt
3. Color Wheel Position
4. Red
5. Green
6. Blue
7. Gobo Wheel
8. Rotate Mode
9. Zoom
10. Focus

Partial Sample :  
Generic Moving Head DMX Channel Functions and Values

MODE / CHANNEL		VALUE	FUNCTION
BASIC	EXTENDED		
1	1	0-255	PAN MOVEMENT
			PAN Movement
	2	0-255	PAN FINE MOVEMENT [16 BIT]
			Fine Control of PAN Movement
2	3	0-255	TILT MOVEMENT
			TILT Movement
	4	0-255	TILT MOVEMENT [16 BIT]
			Fine Control of TILT Movement
3	5		COLOR WHEEL
		0-15	OPEN / WHITE
		16-23	RED
		24-31	BLUE
		32-39	GREEN
		40-47	YELLOW
		48-55	PURPLE
		56-63	AQUA
		64-71	ORANGE
		72-79	LIGHT PINK
		80-87	LIME GREEN
		88-95	LIGHT YELLOW
		96-103	MAGENTA
		104-111	CTB
		112-119	CTO
		120-127	UV
		128-189	Counterclockwise COLOR Rotation from FAST to SLOW
190-193	NO Rotation		
194-255	Clockwise COLOR Rotation from SLOW to FAST		

## 2. Industry Standards

Before 1986, most manufacturers used their own proprietary control protocols, forcing system designers to mostly use fixtures and control consoles from the same manufacturer. Although there was no control standard to allow the use of a different manufacturer's products, a number of companies developed adapters and patches for this purpose, which created control arrangements that were overly complex and somewhat expensive.

Given that a control standard comprises a set of widely agreed-upon guidelines for interoperability at both communications and mechanical level, standardization of protocol and equipment provides many benefits to manufacturers and end users, which include:

- Increased product quality and safety
- Reduced development time and cost
- Sound engineering practices
- General cost savings via protection against product obsolescence

The following organizations have developed standards that relate directly to the DMX 512 protocol:

- **USITT**
- **ESTA**
- **ANSI**
- **EIA/TIA**

### 2.1 USITT

The United States Institute of Theatre Technology (USITT) supports, develops, and promotes a wide variety of standards for the theatrical and entertainment industry. In 1986, USITT developed the DMX 512 protocol as a simple, flexible, and reliable standard for lighting control.

In 1998, USITT transferred maintenance of the DMX 512 protocol to the Technical Standards Program of ESTA. The standard is constantly revised and updated as technology advances.

### 2.2 ESTA

The Entertainment Services and Technology Association (ESTA) is a non-profit trade association representing the entertainment technology industry. ESTA promotes professionalism and growth in the industry and provides a forum where interested parties can come together to exchange ideas and information, create standards and recommended practices, and address issues of training and certification.

## 2.3 ANSI

The American National Standards Institute (ANSI) is an organization composed of representatives from industry and government that collectively determine standards for the electronics industry as well as many other fields, such as chemical and nuclear engineering, health and safety, and construction. ANSI also represents the United States in setting international standards. New electronic equipment and methods must undergo extensive testing to obtain ANSI approval.

In 2004, ANSI approved the DMX 512 standard, and has since approved several other related standards including Remote Device Management (RDM) and Architecture for Control Networks (ACN). The actual standards are listed below:

- ANSI E1.11-2004 - Entertainment Technology USITT DMX512-A - Asynchronous Serial Digital Data Transmission Standard for Controlling Lighting Equipment and Accessories
- ANSI E1.20 - Entertainment Technology RDM - Remote Device Management over USITT DMX512
- ANSI E1.17 - Entertainment Technology ACN – Architecture for Control Networks (Multipurpose Network Control Protocol Suite).

## 2.4 EIA/TIA

The Electronics Industry Alliance (EIA) was a trade organization composed of representatives from electronics manufacturing firms across the United States. EIA began in 1924 as the Radio Manufacturers Association (RMA), and grew to include manufacturers of televisions, semiconductors, computers, and networking devices. The group set standards for its members, helped write ANSI standards, and lobbied for legislation favorable to growth of the computer and electronics industry. On February 11, 2011, the EIA ceased operations.

Although EIA ceased operating, several of its subgroups continue to operate autonomously, namely the Telecommunications Industry Association (TIA). The EIA/TIA-485 standard is the communication basis for DMX 512.

## 2.5 References

For more information on any of these organizations or standards, visit their websites:

- [www.usitt.org](http://www.usitt.org)
- [www.esta.org](http://www.esta.org)
- [www.ansi.org](http://www.ansi.org)
- [www.tiaonline.org](http://www.tiaonline.org)

### 3. Theory of Operation

In technobabble, DMX 512 is an asynchronous serial digital data protocol. This section will attempt to explain how DMX operates in a simplified and easy-to-understand manner using a Cable TV Analogy and DMX Communications.

#### 3.1 The Cable TV Analogy

A central concept of DMX 512 is the ability to transmit data on multiple channels over a single cable. To better understand this concept, imagine a simple cable TV system with four major components: a Cable TV Company, a Cable, a Decoder, and TV.

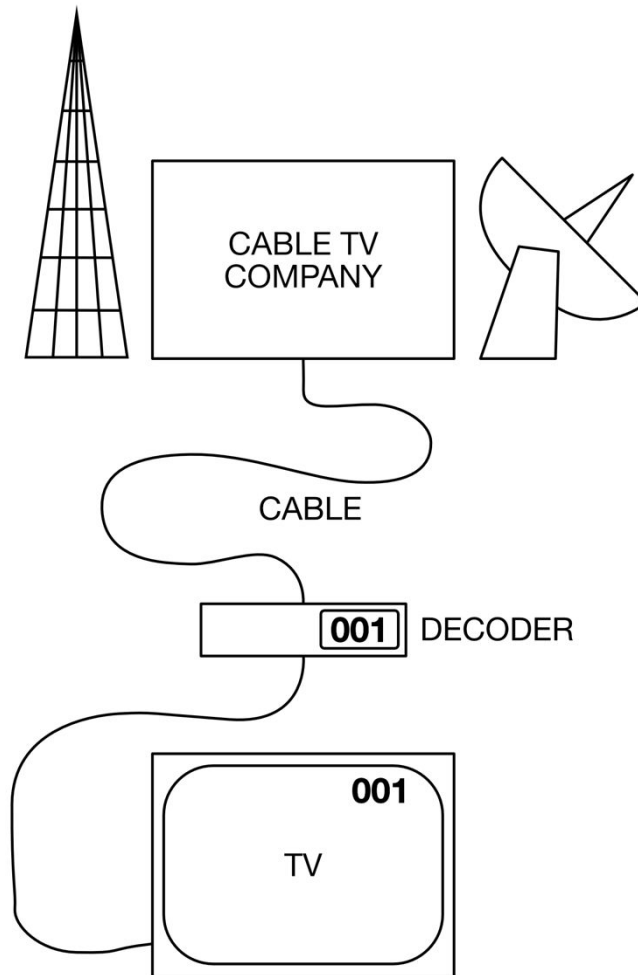

The DMX Control Console will broadcast up to 512 channels over one DMX Cable. Some of these channels may not be used, but will still be transmitted, as required by the protocol. The Decoder in this example is built into the Dimmer. It must be set to a desired channel (channel 001, in this example) to control the connected Light Fixture. This is usually accomplished using a DIP switch (manual electric switch), or LED/LCD display. This desired 'channel' is commonly known as the DMX address.

Now imagine a simple DMX system where the Cable TV Company is the DMX Control Console, the Cable is the DMX Cable, the Decoder is the DMX Decoder built into a Dimmer, and the TV is the Light Fixture.

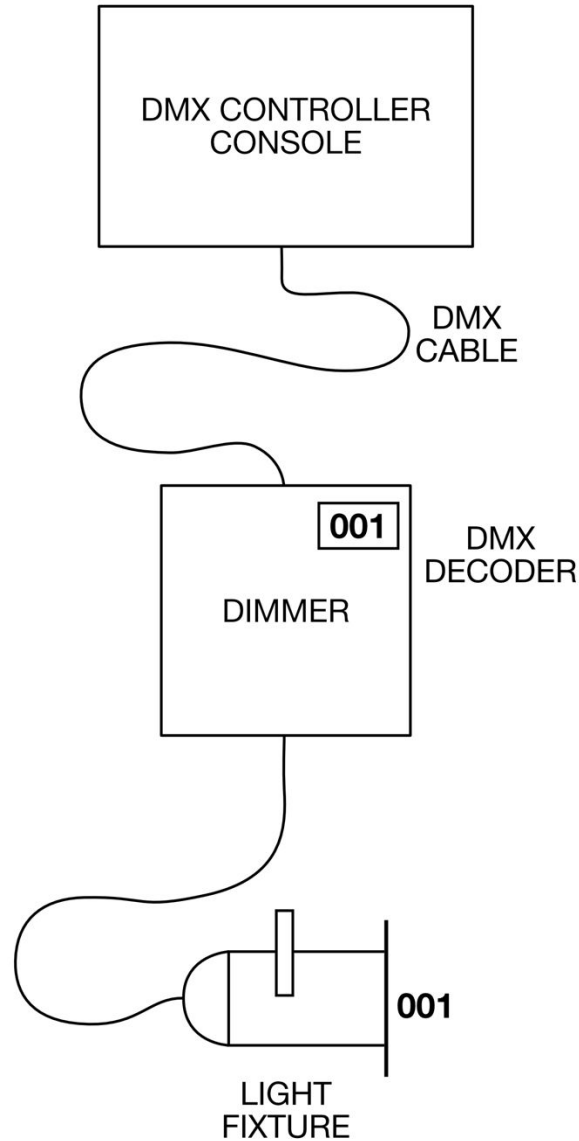

The DMX Control Console will broadcast up to 512 channels over one DMX Cable. Some of these channels may not be used, but will still be transmitted, as required by the protocol. The Decoder in this example is built into the Dimmer. It must be set to a desired channel, as with the previous example, starting with channel 001 to control the connected Light Fixture.

Many DMX devices, such as dimmers and intelligent fixtures, are capable of receiving several control channels at once. If a Dimmer has four channels capable of controlling four Light Fixtures, it must know which four control channels to receive. This is accomplished by setting a 'base address', or the DMX address for the first Light Fixture, channel 005 in this example. The remaining Light Fixtures will be controlled by the next three sequential control channels. The DMX Decoder knows it needs only these four control channels, and will ignore the rest.

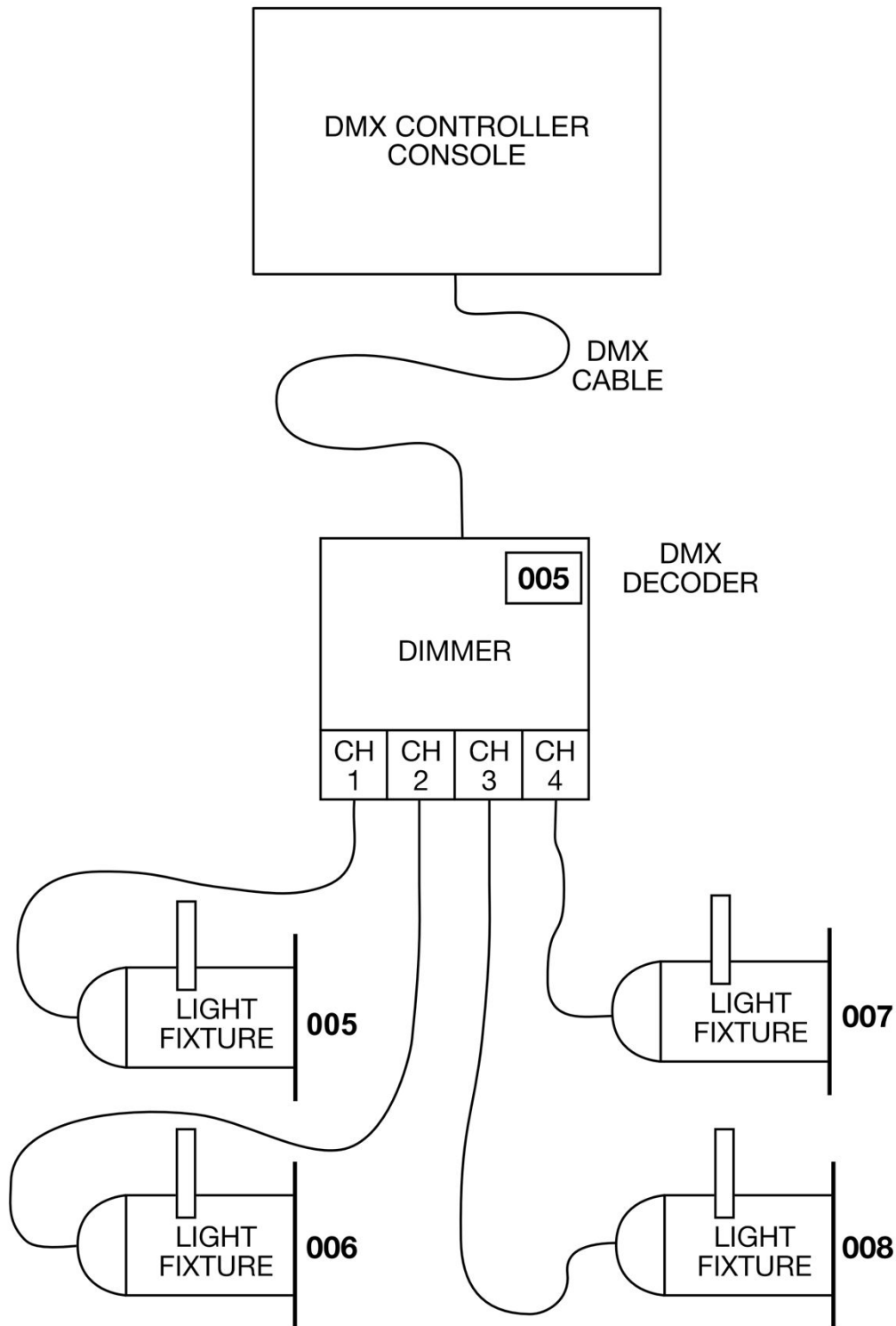

## 3.2 DMX Communications

In the world of digital communications, information is sent using precise electrical voltage pulses. A positive voltage pulse represents a 1, on, and a zero-voltage pulse (or no voltage) represents a 0, off. Systems using 1's and 0's to encode information are called binary systems (a bicycle has two wheels, a binary star system has two suns).

Each pulse in a digital signal is called a binary digit, or bit. A bit can only have one of two values, 1 or 0. A grouping of eight bits, called a byte, is used to carry one piece of information. This 'information' is simply a value ranging from 0 to 255.

The most common method of transmitting digital signals is to send data one bit at a time in one direction over one wire. Since each bit is transmitted in series, this method is known as Serial Communication. In its simplest form, Serial Communication requires one data wire for transmission and one common reference (or ground) wire.

There are two types of serial communication: asynchronous and synchronous. With asynchronous data transmission, data is sent one byte at a time, which means that asynchronous devices do not require perfect synchronization (*a* "not", *syn* "together", and *khronos* "time"). That said, their timing signals (pulses) still need to be somewhat close [at least within a plus or minus 5% range of the data sampling clock circuit, which makes this method relatively simple and inexpensive]. [A data sampling clock circuit is data sent/received relative to its clock position, wherein a stream of data has information in the beginning, center, and end to signal the position of the data within a given or known period (data rate)]. Think of a five second long data signal, which can be sent at a relatively arbitrary time (plus or minus 5% of the clock circuit used), and know that once the beginning of the signal is received, it signals that it will last exactly 5-seconds, with another signal to mark its end. With synchronous data transmission, data is sent as a group of characters in a single stream of bits known as a bitstream. Synchronous serial digital data protocol requires precise and expensive synchronized devices at both ends.

There are many standards for Serial Communications, each having its own advantages and disadvantages. Communications standards generally fall into two broad categories:

- Single-ended (unbalanced)
- Differential (balanced)

The single-ended specifications allow for data transmission from one transmitter to one receiver at relatively slow data rates and short distances. When communicating at high data rates, or over long distances in real-world environments, single-ended transmission methods are often inadequate. Differential data transmission offers superior performance in most applications by helping to nullify the effects of interference on the signal. This is achieved by using two wires to transmit the signal (with opposing polarity) instead of just one.

The DMX 512 protocol is based on the EIA/TIA-485 standard (commonly known as Recommended Standard 485 or RS-485), which uses asynchronous differential data transmission. This standard supports 32 devices on one network at a distance of up to 4000 feet. One device functions as the master (the DMX controller) on a network, while the rest function as slaves (dimmers, intelligent fixtures, etc.). Only the master transmits over the network, and all slaves receive the same data.

While 4000 feet may be specified by the standard, most manufacturers recommend DMX runs of no more than 1000 feet (300 feet between devices) before using a repeater to regenerate the signal. Each device should have input and output connectors, but these are usually wired so that there's no re-transmission or amplification.

Devices are connected in a daisy-chain fashion, from the controller to device #1, then device #1 to device #2, and so on. The final device in the daisy-chain must be terminated. The terminator absorbs signal power which would otherwise be reflected into the cable and degrade the data. A terminator simply places a 110-120 Ohm, 0.5-Watt resistor across the two transmission wires.

**NOTE: DMX cannot be split reliably by making Y-cables or T-connectors. DMX splitter/repeaters typically use optical isolation to protect each segment from electrical faults on other branches. These can be used to increase the number of devices on one network beyond the limit of 32. Each branch of a splitter/repeater can support up to 32 devices.**

### 3.3 Summary

So how does all this information relate to controlling a light fixture? Think of it in terms of the simple DMX Controller Console. The console may have up to 512 control faders on it (8 in this example). Each fader controls the intensity of one light (using one DMX Channel). The position of the fader represents an 8-bit value (DMX Value) between 0 and 255, where 0 is off and 255 is full on.

Up to 32 devices may be connected in a daisy-chain, with a terminator on the last device. Using a DMX splitter/repeater (opto-isolator) can extend both cable distance, as the signal is regenerated and retransmitted, and the number of devices, up to 32 per branch.

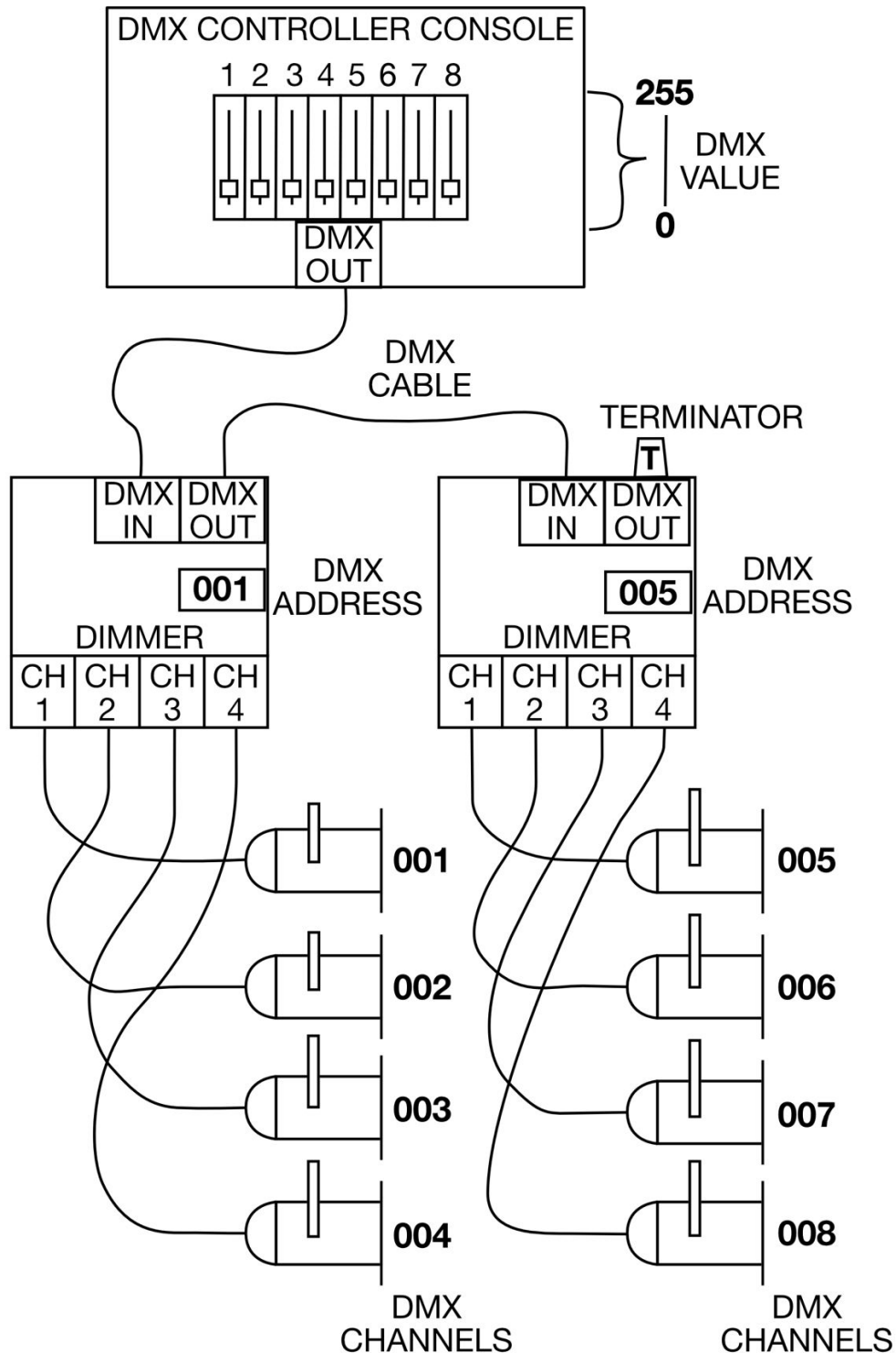

## 4. Protocol Specifications

Understanding how DMX 512 operates is important, but it's only part of the picture. The physical equipment, connectors and cabling, play a critical role in the proper functionality of the protocol. The DMX standard specifies exactly what types of connectors and cable may be used.

It is also important to understand the logic behind the data that is transmitted. Data is sent in a specific manner so that the receiver can correctly translate it into action.

The topics this section will cover are: Connectors, Cabling, and Data.

### 4.1 Connectors

The DMX standard specifies 5-pin XLR connectors. The name comes from the original manufacturer (Cannon **X** connector, with a **L**atch and **R**ubber guard).

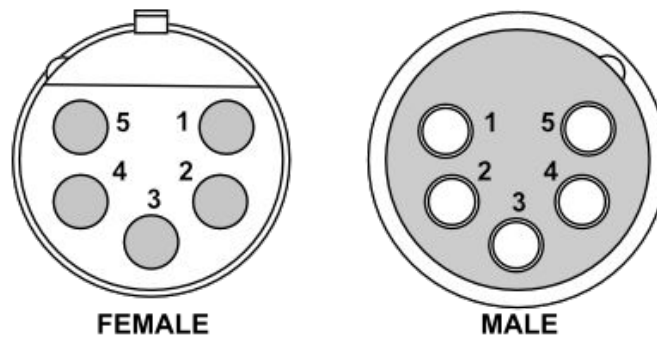

Only three of these pins have standardized use however, leading many companies to make use of inexpensive and readily available 3-pin XLR connectors.

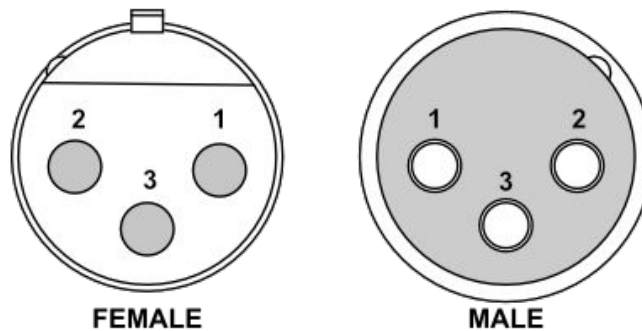

The remaining two pins are in place for potential future usage, such as allowing connected devices to communicate information back to the controller (lamp hours, operating temperatures, etc.).

**DMX 512 Connector Pinout**

Pin	Wire	Signal
1	Shield Drain	Ground / 0V
2	Inner Conductor (Black)	Data -
3	Inner Conductor (White)	Data +
4	Inner Conductor (Green)	Data - (Spare)
5	Inner Conductor (Red)	Data + (Spare)

**NOTE:** Many manufacturers use pins 4 and 5 for non-standard applications, often using voltages that are potentially dangerous to DMX compliant devices. Such applications are meant only for use with approved devices (usually from the same manufacturer). Use with standard DMX devices can cause serious damage to equipment.

## 4.2 Cabling

Standard DMX 512 requires twisted-pair, shielded, low-capacitance data cable designed for RS-485.

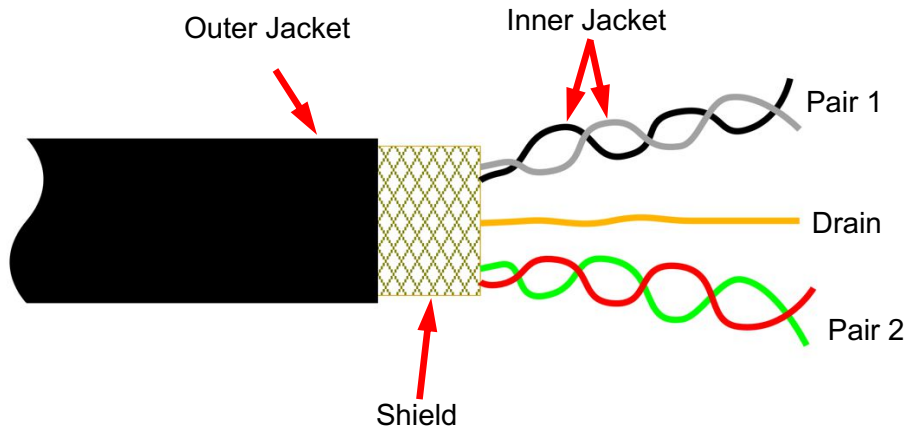

The twisted-pair configuration ensures that any interference affects both signals equally. This practice is common to good data cable, helping the signal driver eliminate any interference. The cable shield also protects against interference. A shield 'drain' wire makes connector installation easier.

There are many cabling characteristics to consider when designing a system. The following list contains a few such characteristics for consideration:

- Impedance (110-120 Ohm recommended)
- Capacitance (< 25 pF cond.-to-cond., < 40 pF cond.-to-shield recommended)
- Attenuation
- Number of conductors/pairs (minimum 1 pair)
- Number of twists per foot
- Conductor material/diameter
- Wire gauge (AWG)
- Maximum current and temperature
- Inner and outer jacket material
- Minimum bend radius
- Maximum pull tension

**NOTE: Many people often substitute a cheaper balanced audio cable (regular microphone cable) with tragic results. An audio cable cannot support the signal rate required by the high speed DMX protocol. While the signal may pass over short distances, it is highly susceptible to interference and degradation, causing unpredictable results (such as blinking lights, confused intelligent fixtures, etc.).**

### 4.3 Data

DMX 512 data is transmitted at 250 kilohertz (kHz), meaning that a maximum of 250,000 1's and 0's can be sent each second. Each bit is measured in 4 microsecond ( $\mu$ s) intervals. In order for the receiving device to correctly interpret the data, it must be sent in a particular sequence. A single transmission (DMX Packet) includes synchronizing elements and channel data for up to 512 channels.



The following table describes each element of the DMX Packet (illustrated above), including its line state, size, and duration. An idle DMX line will have a continuous HI (1) line state.

DMX Packet				
Element	Description	State	Size	Duration
<b>Break</b>	The Break resets the line, signaling a new DMX Packet	LO (0)	22 – 250kbits	88 $\mu$ s - 1 sec.
<b>Mark After Break (MAB)</b>	Inner Conductor (Black)	HI (1)	2 – 250kbits	8 $\mu$ - 1sec.
<b>Start Code (SC)</b>	The SC is identical in size to channel data, but always 0 in value.	Mixed	11 bits	44 $\mu$ s
<b>Mark Time Between Frames (MTBF)</b>	The MTBF is used to space out individual data bytes.	HI (1)	0 – 250kbits	Up to 1 sec.
<b>Channel Data (CD)</b>	The CD carries the 8-bit DMX Value for each channel, plus one start and two stop bits.	Mixed	11 bits	44 $\mu$
<b>Mark Time Between Packets (MTBP)</b>	The MTBP is used to space out entire DMX Packets.	HI (1)	0 – 250kbits	Up to 1 sec.

**NOTE:** At a minimum, a fully loaded DMX Packet (data for all 512 channels) will be around 5700 bits. This means about 44 DMX Packets can be sent each second.

**WARNING:** DMX 512 has no error prevention, and is prohibited from use in life-safety applications such as pyrotechnics, or set / rigging motion control.

## 5. Sample Applications

The figures on the following pages illustrate several different applications using various DMX products. Samples include:

- Dimmer Control
- Intelligent Fixture Control
- Dimmer & Intelligent Fixture Control
- Distributed Control

As mentioned earlier, dimmers normally use one DMX Channel per light. They translate DMX Values in a linear fashion, with 0 being off and 255 full on.

Intelligent fixtures use one DMX Channel per parameter (such as pan, tilt, color, gobo, etc.). How does the controller know which channel controls each parameter? Each intelligent fixture has a DMX Channel Mapping that matches control channels and parameters.

- Channel 1: Pan
- Channel 2: Tilt
- Channel 3: Color
- Channel 4: Gobo
- Channel 5: Dimmer

Pan and tilt functions are linear, but color and gobo functions present a challenge. Imagine a wheel with six colors plus open (no color). How does the controller tell the fixture which color to use? The fixture assigns a DMX Value Mapping to each color.

- 0-35: Open
- 36-70: Red
- 71-105: Cyan
- 106-140: Green
- 141-175: Yellow
- 176-210: Blue
- 211-255: Magenta

The DMX Channel and Value Mappings are typically saved into a computer file for each DMX controller. This file is called a Fixture Profile. In order to use a particular fixture with a controller, a current profile must be loaded. Most controllers come pre-loaded with thousands of fixture profiles from many different manufacturers.

# 5.1 Dimmer Control

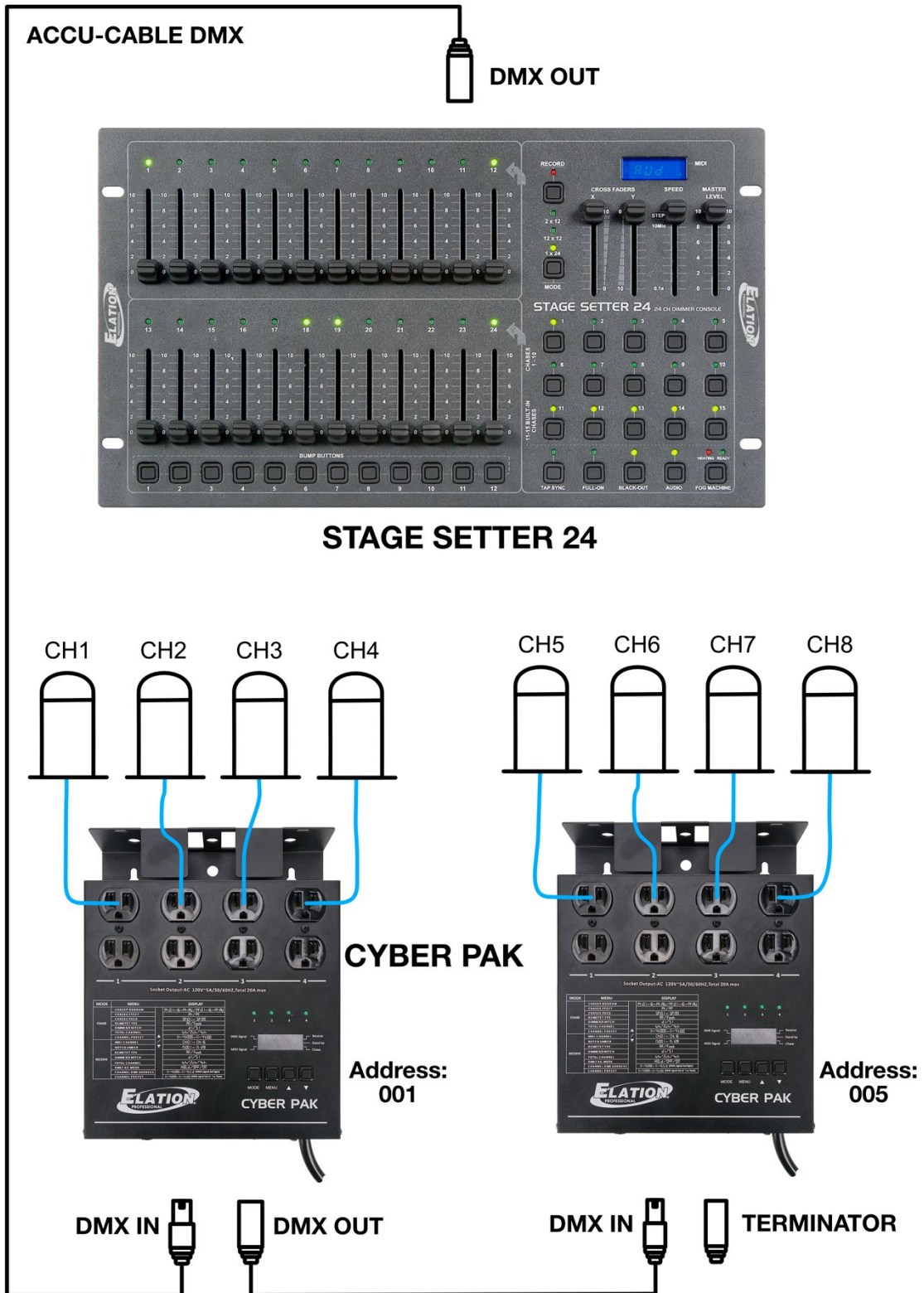

## 5.2 Intelligent Fixture Control



### 5.3 Dimmer and Intelligent Fixture Control

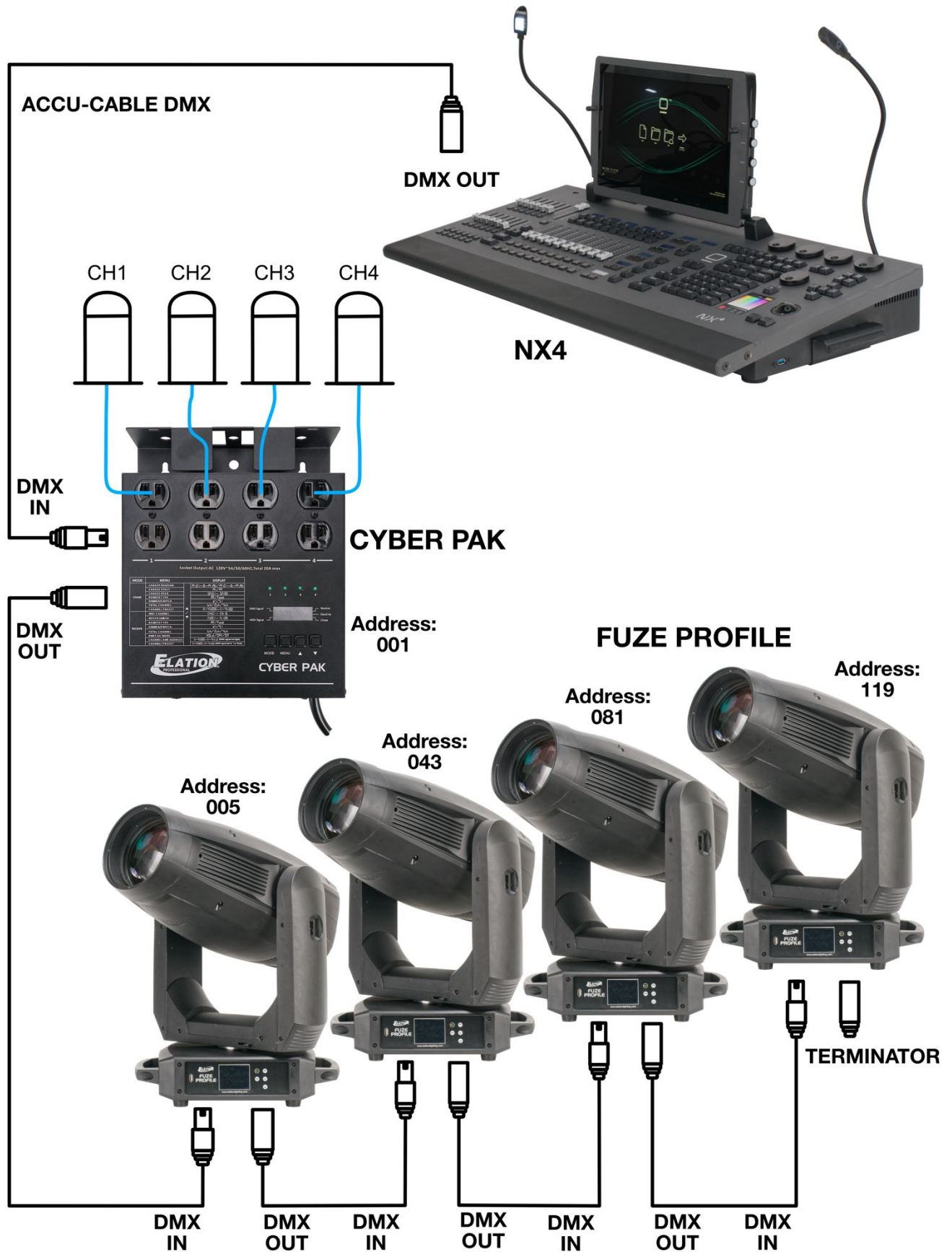

## 5.4 Distributed Control

