

# ELECTRAPIX BAR 16

User Manual

©2026 ADJ Products, LLC all rights reserved. Information, specifications, diagrams, images, and instructions herein are subject to change without notice. ADJ Products, LLC logo and identifying product names and numbers herein are trademarks of ADJ Products, LLC. Copyright protection claimed includes all forms and matters of copyrightable materials and information now allowed by statutory or judicial law or hereinafter granted. Product names used in this document may be trademarks or registered trademarks of their respective companies and are hereby acknowledged. All non-ADJ Products, LLC brands and product names are trademarks or registered trademarks of their respective companies.

**ADJ Products, LLC** and all affiliated companies hereby disclaim any and all liabilities for property, equipment, building, and electrical damages, injuries to any persons, and direct or indirect economic loss associated with the use or reliance of any information contained within this document, and/or as a result of the improper, unsafe, insufficient and negligent assembly, installation, rigging, and operation of this product.

**ADJ PRODUCTS LLC World Headquarters**

6122 S. Eastern Ave. | Los Angeles, CA 90040 USA

Tel: 800-322-6337 | Fax: 323-582-2941 | [www.adj.com](http://www.adj.com) | [lsupport@adj.com](mailto:lsupport@adj.com)

**ADJ Supply Europe B.V.**

Junostraat 2 | 6468 EW Kerkrade | Netherlands

Tel: +31 45 546 85 00 | Fax: +31 45 546 85 99 | [www.adj.eu](http://www.adj.eu) | [support@adj.eu](mailto:support@adj.eu)

**Europe Energy Saving Notice**

Energy Saving Matters (EuP 2009/125/EC)

Saving electric energy is a key to help protecting the environment. Please turn off all electrical products when they are not in use. To avoid power consumption in idle mode, disconnect all electrical equipment from power when not in use. Thank you!

**DOCUMENT VERSION**



Due to additional product features and/or enhancements, an updated version of this document may be available online.

Please check [www.adj.com](http://www.adj.com) for the latest revision/update of this manual before beginning installation and/or programming.

| Date       | Document Version | Software Version | DMX Channels                  | Notes  |
|------------|------------------|------------------|-------------------------------|--|
| 03/18/2024 | 1.0              | 1.0              | 5/6/9/13/22/24/96/99/114      | Initial Release  |
| 05/16/2024 | 1.1              | N/C              | N/C                           | Updated Adjustable Mounting Bracket.   |
| 11/15/2024 | 1.2              | 1.01             | N/C                           | Added Storage and Transportation   |
| 02/17/2025 | 1.3              | N/C              | N/C                           | Updated Specifications, FCC Statement  |
| 04/09/2025 | 1.4              | N/C              | N/C                           | Updated Specifications, Dimensions   |
| 04/24/2026 | 1.5              | 1.03             | 5/6/7/9/12/13/22/24/96/99/114 | Updated: General Info, System Menu, DMX Setup, DMX Traits, RDM, Specifications |

# CONTENTS

|   |           |
|---|-----------|
| <b>General Information</b>                  | <b>4</b>  |
| <b>Features</b>                             | <b>5</b>  |
| <b>IP65 Rated</b>                           | <b>6</b>  |
| <b>Storage and Transportation</b>           | <b>7</b>  |
| <b>Safety Guidelines</b>                    | <b>8</b>  |
| <b>Battery Warnings</b>                     | <b>10</b> |
| <b>Overview</b>                             | <b>11</b> |
| <b>Torque Settings for Screws</b>           | <b>12</b> |
| <b>IP Test Parameters</b>                   | <b>13</b> |
| <b>Installation Guidelines</b>              | <b>14</b> |
| <b>Accessory Installations</b>              | <b>18</b> |
| <b>Frost Filter</b>                         | <b>18</b> |
| <b>Glare Shield</b>                         | <b>19</b> |
| <b>L-Track</b>                              | <b>20</b> |
| <b>VFB1 Floor Base</b>                      | <b>21</b> |
| <b>Battery Charger</b>                      | <b>22</b> |
| <b>System Menu</b>                          | <b>23</b> |
| <b>Dimmer Modes and Curves</b>              | <b>28</b> |
| <b>Remote Control Guidelines</b>            | <b>29</b> |
| <b>IR Default Values</b>                    | <b>30</b> |
| <b>DMX Setup</b>                            | <b>31</b> |
| <b>DMX Traits</b>                           | <b>33</b> |
| <b>Color Temperature</b>                    | <b>36</b> |
| <b>Color Macro Chart: RGBAL+UV</b>          | <b>37</b> |
| <b>Color Macro Chart: Background</b>        | <b>38</b> |
| <b>Pixel Flip</b>                           | <b>39</b> |
| <b>Remote Device Management (RDM)</b>       | <b>40</b> |
| <b>Cleaning and Maintenance</b>             | <b>41</b> |
| <b>Specifications</b>                       | <b>42</b> |
| <b>Dimensions</b>                           | <b>43</b> |
| <b>Optional Accessories   FCC Statement</b> | <b>44</b> |

# GENERAL INFORMATION

## INTRODUCTION

Please read and understand all instructions in this manual carefully and thoroughly before attempting to operate these products. These instructions contain important safety and use information.

## UNPACKING

This device has been thoroughly tested and has been shipped in perfect operating condition. Carefully check the shipping carton for damage that may have occurred during shipping. If the carton appears to be damaged, carefully inspect the device for damage and be sure all accessories necessary to operate the device have arrived intact. In the event damage has been found or parts are missing, please contact our customer support team for further instructions. Please do not return this device to your dealer without first contacting customer support at the number listed below. Please do not discard the shipping carton in the trash. Please recycle whenever possible.

## CUSTOMER SUPPORT

Contact ADJ Service for any product related service and support needs. Also visit [forums.adj.com](https://forums.adj.com) with questions, comments or suggestions.

**Parts:** To purchase parts online visit:

<http://parts.adj.com> (US)

<http://www.adjparts.eu> (EU)

**ADJ SERVICE USA - Monday - Friday 8:00am to 4:30pm PST**

Voice: 800-322-6337 | [support@adj.com](mailto:support@adj.com)

**ADJ SERVICE EUROPE - Monday - Friday 08:30 to 17:00 CET**

Voice: +31 45 546 85 60 | [support@adj.eu](mailto:support@adj.eu)

**ADJ PRODUCTS LLC USA**

6122 S. Eastern Ave. Los Angeles, CA. 90040

323-582-2650 | [www.adj.com](http://www.adj.com) | [info@adj.com](mailto:info@adj.com)

**ADJ SUPPLY Europe B.V**

Junostraat 2 6468 EW Kerkrade, The Netherlands

+31 (0)45 546 85 00 | [www.adj.eu](http://www.adj.eu) | [info@adj.eu](mailto:info@adj.eu)

**ADJ PRODUCTS GROUP Mexico**

AV Santa Ana 30 Parque Industrial Lerma, Lerma, Mexico 52000

+52 (728) 282-7070

## LIMITED WARRANTY

For up-to-date warranty information regarding your device, please visit ADJ's warranty information page online or scan the QR codes below.



USA: <https://www.adj.com/pages/warranty-information>



EU: [https://www.adj.eu/terms\\_and\\_conditions](https://www.adj.eu/terms_and_conditions)

It is strongly recommended to power the fixture down completely when not in use. Doing so will reduce wear on the fixture due to sustained or extended operational periods, thereby maximizing its operational lifespan.

# FEATURES

The ADJ Lighting ElectraPix Bar 16 is a cutting-edge, 1-Meter battery powered, wireless DMX lighting solution. Packed with advanced features, this fixture boasts sixteen 20-Watt Hex Color LED (RGBAL+UV), providing unparalleled control and creativity. Powered by either batteries or wall outlets, it offers 5 hours of standard battery operation or an extended 10-hour saver mode.

With individual pixel control, built-in foreground and background LED programs, and a variable white color temperature range, the ElectraPix Bar 16 ensures dynamic lighting possibilities. Its color-calibrated LEDs, user-selectable dim modes, and electronic strobe/dimming enhance versatility.

Designed for adaptability, the IP65-Rated housing, OLED digital display, L Track system, and adjustable feet make installation and customization a breeze. Additional, up to two ElectraPix Bar 16 fixtures may be mounted vertically to the VFB1 floor base (sold separately). The fixture's control options include DMX512, Aria X2 Wireless DMX, Bluetooth, RDM compatibility, and an included UCIR24 wireless remote.

The ElectraPix Bar 16 guarantees reliability with certifications such as CE, FCC, and pending cETLus, while its IP65-Rating ensures durability in various environments. Included accessories like the outdoor locking power cable and UCIR24 remote, along with optional add-ons, make this fixture a comprehensive lighting solution for professionals. Elevate your lighting design with the ElectraPix Bar 16, where innovation meets performance.

## **INCLUDED ITEMS:**

- (1) Outdoor Locking Power Cable
- (1) UCIR24 Remote
- (1) 20° Diffusion Filter

# IP65 RATED

The **International Protection (IP)** rating system is commonly expressed as “**IP**” (Ingress Protection) followed by two numbers (i.e. IP65), where the numbers define the degree of protection. The first digit (Foreign Bodies Protection) indicates the extent of protection against particles entering the fixture, and the second digit (Water Protection) indicates the extent of protection against water entering the fixture. An **IP65** rated lighting fixture is designed and tested to protect against the ingress of dust (6), and low-pressure water jets from any direction (5).

**NOTE: THIS FIXTURE IS INTENDED FOR TEMPORARY OUTDOOR USE ONLY!**

**Maritime/Coastal Environment Installations:** A coastal environment is seaside adjacent, and caustic to electronics through exposure to atomized salt-water and humidity, whereas maritime is anywhere within 5-miles of a coastal environment.



**NOT suitable for maritime/coastal environment installations. Installing this fixture in a maritime/coastal environment may cause corrosion and/or excessive wear to the interior and/or exterior components of the fixture. Damages and/or performance issues resulting from installation in a maritime/coastal environment will void the manufactures warranty, and will NOT be subject to any warranty claims and/or repairs.**

Maritime installations require additional preparation, and additional service intervals may be needed given the maritime use. In general, IP ratings presuppose freshwater conditions VS maritime conditions, which are typically more “caustic” to IP fixtures (both internally and externally). A duty-cycle may also be needed when units are not in use. During times of high humidity and colder temperatures, condensation may occur internally so the fixture may require a duty-cycle to bring it up to running temperature, allowing any accumulation of moisture to be expelled via the vent valve. Recommendations can change based on installation environmental circumstances. A waterproof dome or similar device is recommended for use in permanent outdoor installations. When using a dome, refer to manufacturer recommendations for duty-cycle.

**NOTE: NOT ALL FEATURES LISTED ARE AVAILABLE ON ALL FIXTURES; THE FOLLOWING INSTRUCTIONS MAY NOT APPLY. CONTACT SUPPORT FOR ADDITIONAL DETAILS.**

**Exterior Maintenance:** Inspect the exterior every 30-days. The unit must be powered off/disconnected. Inspect optics to determine if the lens is obstructed, then clean optics and chassis accordingly. Based on initial finding, schedule maintenance accordingly, keeping in mind that exterior maintenance will be required. Even if the luminaires are NOT in use, maintenance will still be needed given its location (exterior use). The use of a durable type of wax on the chassis is recommended since it will help prevent contaminant build up. Inspect both power and data lines for any signs of contaminants or corrosion. Periodically reapplying di-electric grease, especially in coastal environments. If any signs of corrosion/contaminants are present, clean thoroughly, and/or replace connectors, then reapply di-electric grease. Typically, this should be done annually, or any time an opportunity presents itself. As a preventive measure, annual replacement of both vent valves is recommended. The vent valve membrane can become contaminated and/or clogged causing improper venting of humidity within the luminaire. Inspect all mounting hardware as a precaution.

**Interior Maintenance:** Inspect the interior every 30-days. The unit must be powered off/disconnected.

- Inspect zoom/focus mechanism, clean optics, lubricate linear bearings (Krytox oil) as needed, inspect belts for wear
- Inspect all rotating effect wheels, manually rotate them, note any resistance
- Inspect all remaining rotating belts for any wear
- Inspect all fans, clean as needed, check rotation, check connections
- Inspect CMY module, manually move flags and check for signs of resistance, and if needed, clean guide rods first, then reapply a thin layer of grease (moly lube)
- Clean interior with low-volume compressed air, then clean optics prior to reassembly of head covers

Although the base has limited moving parts, the pan belt should also be inspected for wear. Remember to always perform an IP test anytime a cover is removed.

There is no specific time frame regarding the routine replacement of parts such as belts/stepper motors, PCBs, or LEDs. These items should only be replaced on an as needed bases, except for cooling fans, which should be replaced once the luminaries reach 10,000-hours. This is a prophylactic measure intended to keep the unit running as cool as possible, insuring proper function of all internal components. A complete service breakdown is available, please contact [service@adj.com](mailto:service@adj.com) for any needed parts or manuals.

# STORAGE AND TRANSPORTATION

When storing or transporting your fixtures in the optional ADJ road case, please be sure to orient your fixtures correctly! The fixture should be oriented with the charging port facing downwards, and the protruding connector brackets on one end of the fixture should be pointing away from the cable/Accessory compartment. If oriented correctly, the connector brackets should fit snugly into the foam cutouts along the edge of the road case.

**FAILURE TO ORIENT THE FIXTURES CORRECTLY MAY RESULT IN IMPACT DAMAGE TO THE CHARGER COMPONENTS, DISPLAY SCREEN, AND/OR CONTROL BUTTONS!**

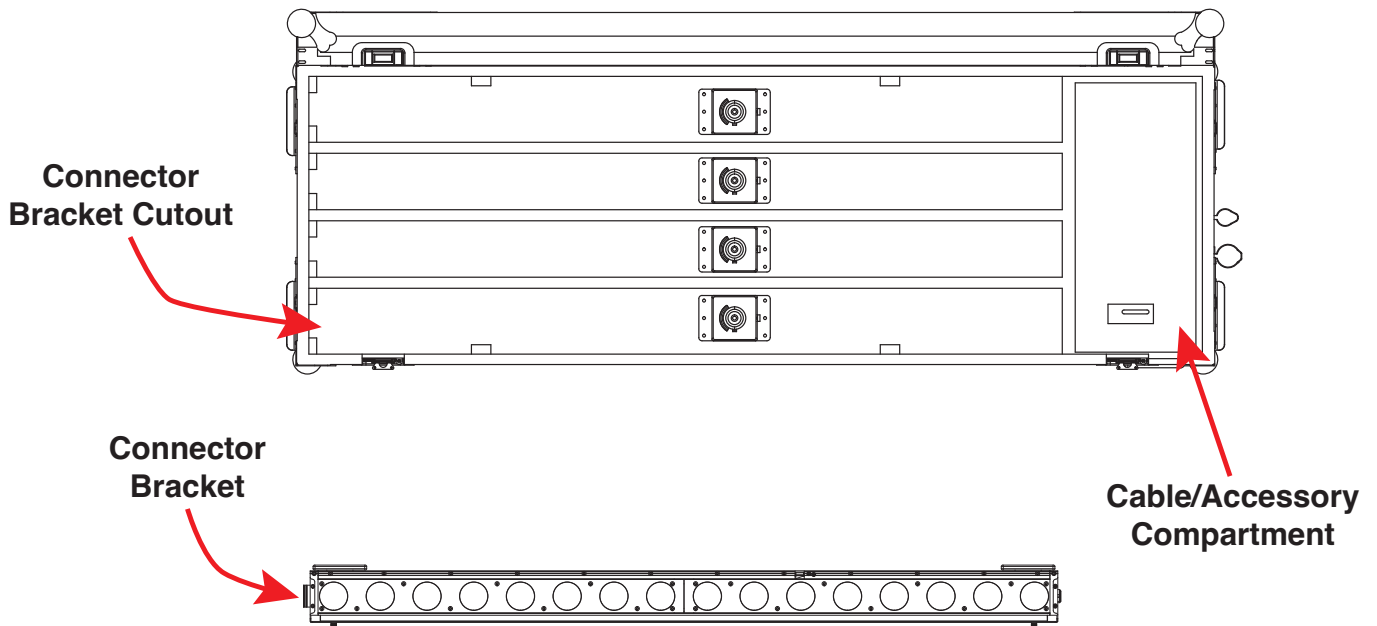

# SAFETY GUIDELINES



**PROTECTION CLASS 1 - FIXTURE MUST BE PROPERLY GROUNDED.**



**THERE ARE NO USER SERVICEABLE PARTS INSIDE THIS UNIT. DO NOT ATTEMPT ANY REPAIRS YOURSELF, AS DOING SO WILL VOID YOUR MANUFACTURER'S WARRANTY. DAMAGES RESULTING FROM MODIFICATIONS TO THIS FIXTURE AND/OR THE DISREGARD OF SAFETY INSTRUCTIONS AND GUIDELINES IN THIS MANUAL VOID THE MANUFACTURER'S WARRANTY AND ARE NOT SUBJECT TO ANY WARRANTY CLAIMS AND/OR REPAIRS.**

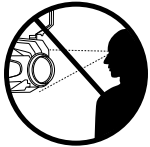

**NEVER LOOK DIRECTLY INTO THE LIGHT SOURCE!  
RETINA INJURY RISK - MAY INDUCE BLINDNESS!  
SENSITIVE PERSONS MAY SUFFER AN EPILEPTIC SHOCK!**

- **Ambient operating temperature range is -4°F to 113°F (-20°C to 45°C)!**
- **DO NOT TOUCH** the fixture housing during operation. Disconnect the power and allow approximately 15 minutes for the fixture to cool down before servicing.
- **DO NOT** shake the fixture, and avoid brute force when installing and/or operating the fixture.
- **DO NOT** operate the fixture if the power cord has become frayed, crimped and/or damaged. If the power cord is damaged, replace immediately with a new one of the same power rating.
- **DO NOT** attempt to remove or break off the ground prong from the electrical cord. This prong is used to reduce the risk of electrical shock and fire in case of an internal short.
- **DO NOT** attempt to operate this unit if it has been damaged in any way.
- Disconnect from main power before making any type of connection.
- **DO NOT** block any air ventilation slots. All fan and air inlets must remain clean and never blocked. Allow approx. 6" (15cm) between fixture and other devices or a wall for proper cooling.
- Always be sure to mount this unit in an area that will allow proper ventilation. Allow about 6" (15cm) between this device and a wall.
- **DO NOT** remove the cover for any reason.
- When installing fixture in a suspended environment, always use mounting hardware that is no less than M10 x 25mm, and always install fixture with an appropriately rated safety cable.
- Never plug this unit in to a dimmer pack.
- During long periods of non-use, disconnect the unit's main power.
- Always mount this unit in safe and stable matter.
- Power-supply cords should be routed so that they are not likely to be walked on or pinched by items placed upon or against them, paying particular attention to the point where they exit from the unit.
- Cleaning - The fixture should be cleaned only as recommended by the manufacturer.
- Heat - The appliance should be situated away from heat sources such as radiators, heat registers, stoves, or other appliances (including amplifiers) that produce heat.
- The fixture should be serviced by qualified service personnel when:
  - A. The power-supply cord or the plug have been damaged.
  - B. Objects have fallen onto, or liquids have been spilled into, the fixture.
  - C. The fixture does not appear to operate normally or exhibits a marked change in performance.
  - D. The fixture has fallen and/or has been subjected to extreme handling.

# SAFETY GUIDELINES



**HIGH  
INTENSITY  
ULTRAVIOLET  
LIGHT**

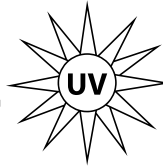

**AVOID DIRECT EYE & SKIN EXPOSURE.  
WEAR PROPER EYE & SKIN PROTECTION.  
SEE MANUAL FOR SAFETY INSTRUCTIONS.**

**RISK GROUP 3 - RISK OF EXPOSURE TO ULTRAVIOLET UV RADIATION! FIXTURE EMITS HIGH INTENSITY WAVELENGTH OF ULTRAVIOLET UV LIGHT FROM THE UV COLOR FILTER. WEAR PROPER EYE AND SKIN PROTECTION. AVOID PROLONGED PERIODS OF EXPOSURE TO UV COLOR FILTER. AVOID WEARING WHITE COLOR CLOTHING AND/OR USING UV PAINTS ON SKIN. AVOID DIRECT EYE AND/OR SKIN EXPOSURE AT DISTANCES LESS THAN 10 feet (3m). DO NOT OPERATE FIXTURE WITH DAMAGED/MISSING EXTERNAL COVERS. DO NOT LOOK DIRECTLY INTO THE UV LIGHT AND/OR VIEW UV LIGHT DIRECTLY WITH OPTICAL INSTRUMENTS THAT MAY CONCENTRATE THE LIGHT/RADIATION OUTPUT. INDIVIDUALS SUFFERING FROM A RANGE OF EYE CONDITIONS, SUNLIGHT EXPOSURE DISORDERS, OR INDIVIDUALS USING PHOTSENSITIVE MEDICATION, MAY RECEIVE DISCOMFORT IF EXPOSED TO THE ULTRAVIOLET UV LIGHT EMITTED FROM THE UV LED.**

# BATTERY WARNINGS

## HANDLING PRECAUTIONS

**Do not short circuit the battery.** Avoid subjecting the battery to a short circuit, as doing so generates a very high current, resulting in overheating, electrolyte gel leakage, harmful fumes, explosion risk, or other damage to the battery.

**Mechanical shock.** Dropping, impacting, striking, or bending the unit, or subjecting the unit to any other types of mechanical shock may cause failure or shortend life of the battery.

**Do not disassemble the batteries.** Never disassemble the batteries, as doing so may result in an internal short circuit in the battery, leading to fire, explosion, release of harmful fumes, or other hazards. Electrolyte gel is harmful, and contact should be avoided whenever possible. Should the electrolyte gel come into contact with the skin or eyes, flush the area of contact immediately with fresh water and seek medical attention immediately.

**Do not expose battery to heat or fire.** Never incinerate or dispose of the batteries in fire, as this could result in an explosion.

**Do not exposure the battery to water or liquids.** Never expose or immerse the batteries in liquids of any type, including water, seawater, soft drinks, juices, coffee, or other beverages.

**Battery Replacement.** For battery replacement please contact customer support.

**Never use a damaged battery.** Shipping carries a risk of damage to the battery. Should damage be observed, including damage to the plastic casing of the battery, deformation of the battery package, chemical or electrolyte odor, or leakage of the electrolyte gel, or any other miscellaneous damage, **DO NOT use the battery.** A battery with a odor of electrolyte or a gel leakage should be placed away from fire to avoid risk of fire or explosion.

**Battery Storage.** The battery should be stored at room temperature, with a charge of at least 50%. During long periods of storage, it is recommended that the battery be charged every 6 months. Doing so will prolong the life of the battery and will also make sure that the battery charge does not fall below the 30% mark.

**Other Chemical Reactions.** Because batteries rely on a chemical reaction to work, battery performance will deteriorate over time, even if stored for a long period of time without being used. In addition, if various usage conditions (such as charge, discharge, ambient temperature, etc.) are not maintained within the specified ranges, the life expectancy of the battery maybe shortened or the device in which the battery is used may be damaged by electrolyte gel leakage. If the batteries cannot maintain a charge for long periods of time, even when they are charged correctly, this may indicate the need to replace the battery.

**Battery Disposal.** Please dispose of battery according to local regulations.

# OVERVIEW

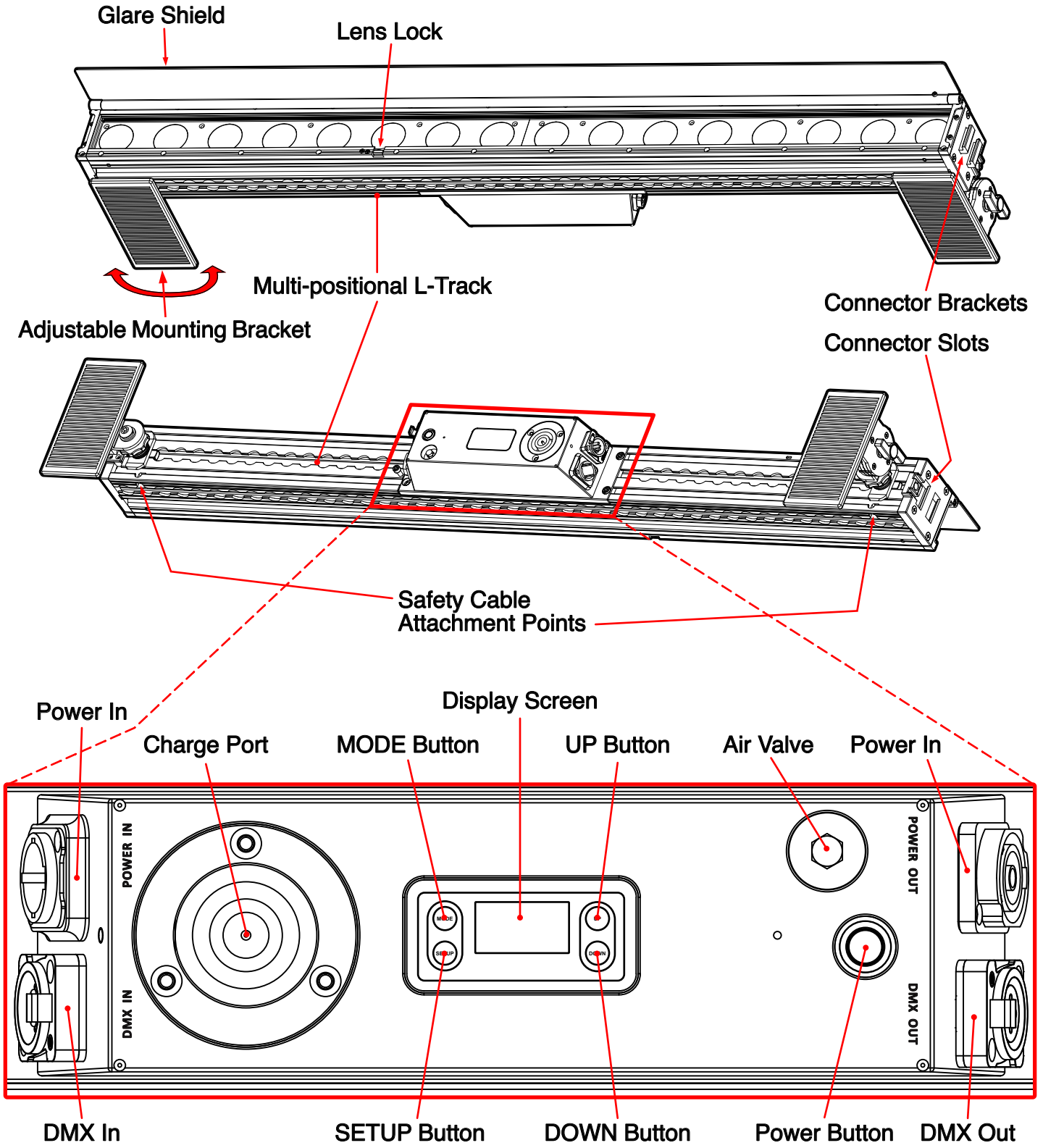

# TORQUE SETTINGS FOR SCREWS

IN ORDER TO MAINTAIN THE IP65 RATING ON THE LIGHTING FIXTURES, ALL SCREWS MUST BE TIGHTENED TO THE FOLLOWING TORQUE SPECIFICATION USING A TORQUE DRIVER.

Refer to the table and diagram below for torque specifications.

TORQUE DRIVERS (Recommended): UTICA TS-30 (shown)

ALTERNATE DRIVERS:

- Proto J6107A
- Wiha 28887



**CAUTION! DO NOT OVER TORQUE SCREWS, AS THIS CAN CAUSE LEAKAGE ISSUES!**

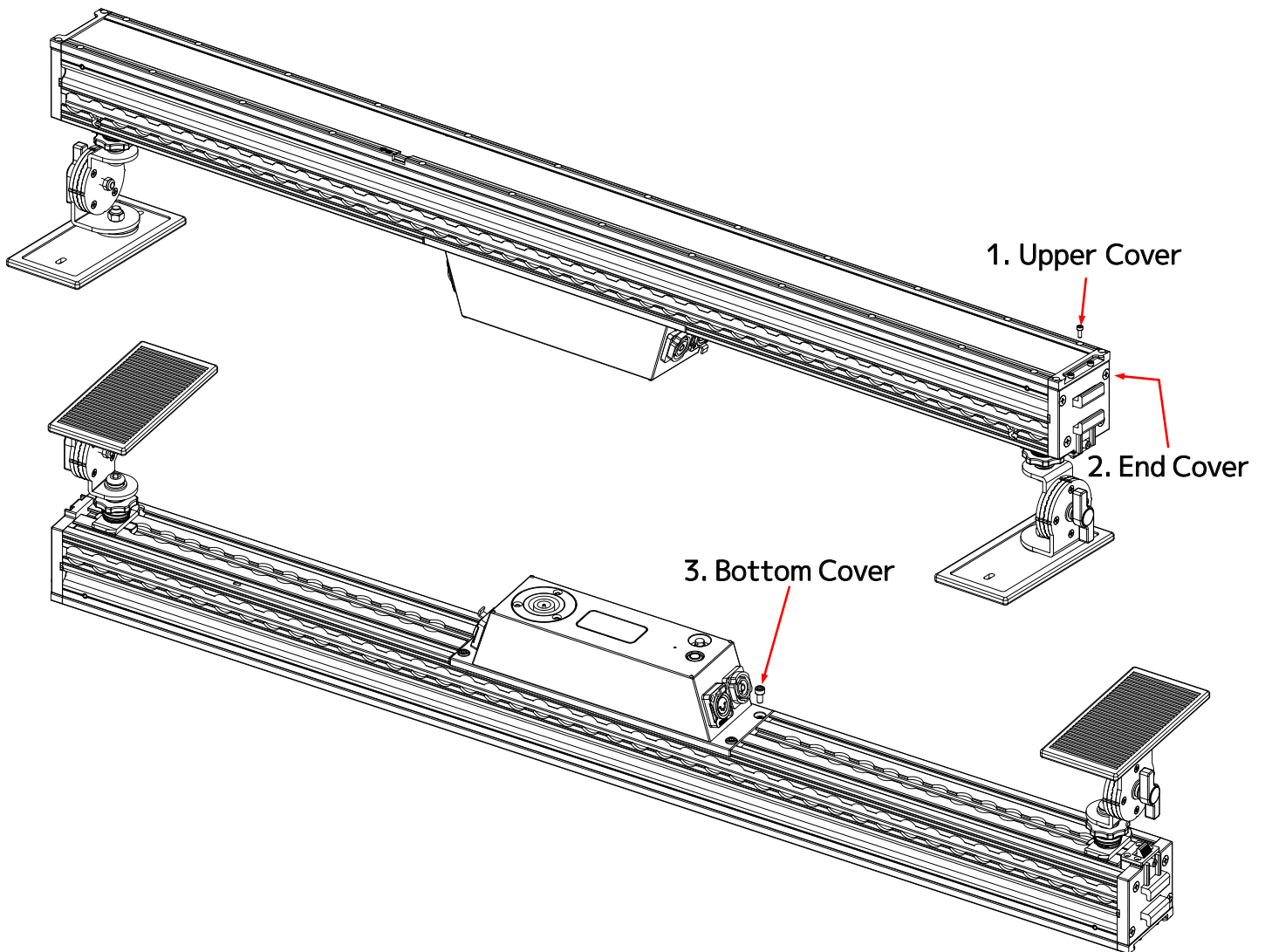

| NO. | LOCATION     | QUANTITY | TORQUE                  |
|-----|--------------|----------|-------------------------|
| 1   | Upper Cover  | 32       | 6.9 lb-in (8.0 kg-cm)   |
| 2   | End Cover    | 8        | 10.4 lb-in (12.0 kg-cm) |
| 3   | Bottom Cover | 4        | 17.4 lb-in (20.0 kg-cm) |

# IP TEST PARAMETERS

Following any repair or maintenance procedure that requires disassembly of the fixture, use ADJ's Hydro IP Tester to confirm the IP integrity of the fixture. The air valve is located on the back panel next to the display screen, as shown in the diagram below. Please contact ADJ Service for information regarding the ADJ Hydro IP Tester, or visit the product information page online at: <https://www.adj.com/hydro-ip-tester>

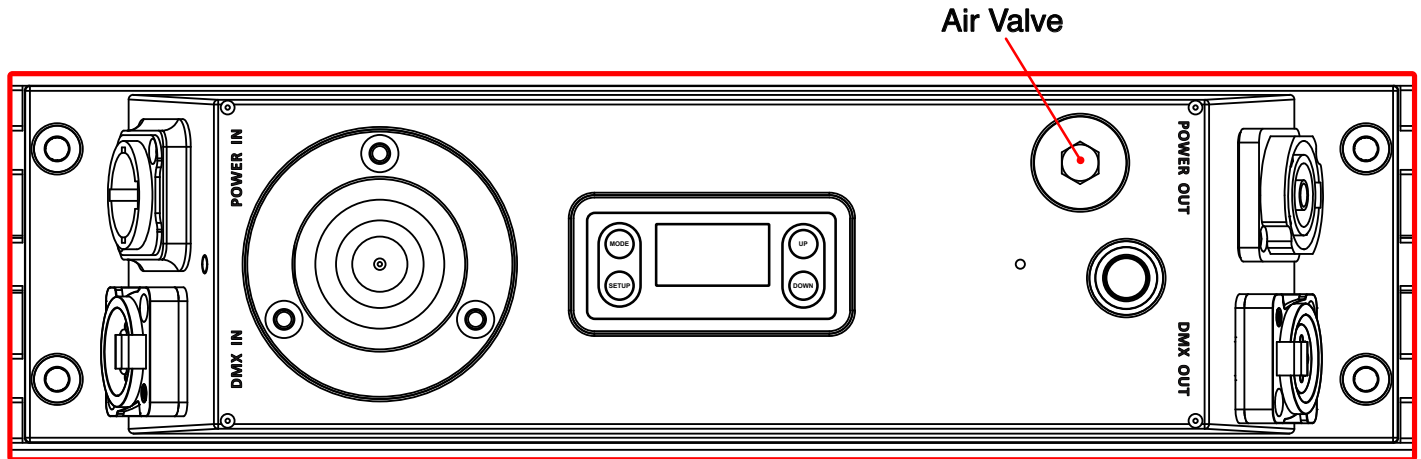

**CAUTION! THE USE OF PROTECTIVE GLOVES AND SAFETY GOGGLES IS STRONGLY RECOMMENDED WHILE PERFORMING THE IP PRESSURE TEST! AVOID PLACING YOUR FACE, EYES, HANDS, ETC IN CLOSE PROXIMITY TO THE FIXTURE'S LENS WHILE PERFORMING THE TEST!**

**DE-HUMIDIFICATION:** IP65 fixtures operating in high-humidity environments may experience residual fogging or condensation. Such fogging will not damage the fixture, and can be removed using the following procedure: position the unit with the air valve pointing upwards, then open the air valve and run the unit for 1-2 hours after reaching operating temperature. Then, while the fixture is still hot, re-install the air valve and allow the unit to cool down. Please note that this procedure should be performed in a dry, air-conditioned environment. Avoid additional fogging by drying the fixture completely before placing into a road case.



| IP PRESSURE TESTING PARAMETERS |                     |                  |
|--------------------------------|---------------------|------------------|
| Low Pressure Limit             | High Pressure Limit | Steady/Hold Time |
| 1.65 psi (11.4 KPa)            | 1.70 psi (11.7 KPa) | 3 sec            |

# INSTALLATION GUIDELINES



## FLAMMABLE MATERIAL WARNING

Keep fixture minimum 5.0 feet (1.5m) away from flammable materials and/or pyrotechnics.



## ELECTRICAL CONNECTIONS

A qualified electrician should be used for all electrical connections and/or installations.



**MINIMUM DISTANCE TO OBJECTS/SURFACES IS 6.6 FEET (2 METERS).**

**MINIMUM DISTANCE OF INFLAMMABLE MATERIALS FROM THE SURFACE IS 1.6 FEET (0.5 METERS).**

## DO NOT INSTALL THE FIXTURE IF YOU ARE NOT QUALIFIED TO DO SO!

- Fixture **MUST** be installed following all local, national, and country commercial electrical and construction codes and regulations.
- Before rigging/mounting a single fixture or multiple fixtures to any metal truss/structure or placing the fixture(s) on any surface, a professional equipment installer **MUST** be consulted to determine if the metal truss/structure or surface is properly certified to safely hold the combined weight of the fixture(s), clamps, cables, and accessories.
- Maximum ambient operating temperature is **113°F (45°C)**. Do not use fixture when ambient temperature exceeds this value.
- Fixture(s) should be installed outside walking paths, seating areas, or areas where unauthorized personnel might reach the fixture by hand.
- **NEVER** stand directly below the fixture(s) when rigging, removing, or servicing.
- Overhead fixture installation must always be secured with a secondary safety attachment, such as an appropriately rated safety cable.
- Allow approximately 60 minutes for the fixture to cool down before servicing.

## RIGGING

**Overhead rigging requires extensive experience, including calculating working load limits, knowledge of installation material being used, and periodic safety inspection of all installation material and the fixture, among other skills. If you lack these qualifications, do not attempt the installation yourself. Improper installation can result in bodily injury.**

# INSTALLATION GUIDELINES

## CLAMP INSTALLATION

This fixture features brackets for the attachment of mounting clamps. There are also safety cable attachment points located on the heatsink near each endcap. When mounting the fixture to a truss or any other suspended or overhead installation, be sure to secure appropriately rated clamps (not included) to the brackets, and attach a separate SAFETY CABLE of the appropriate weight rating to a safety cable attachment point.

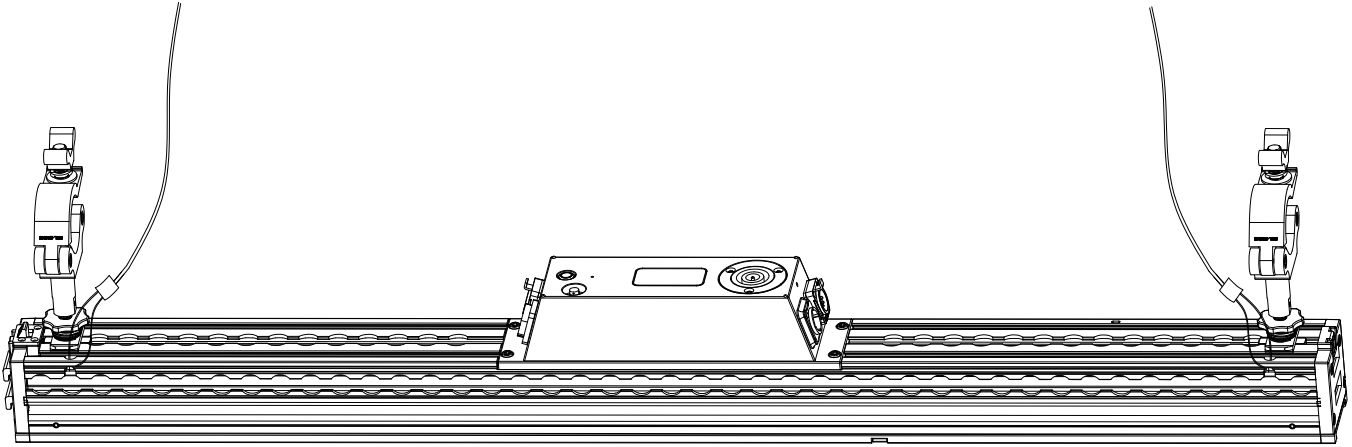

### SAFETY CABLE:



**ALWAYS ATTACH A SAFETY CABLE WHENEVER INSTALLING THIS FIXTURE IN A SUSPENDED ENVIRONMENT TO ENSURE THAT THE FIXTURE WILL NOT FALL IF THE CLAMPS FAIL.**

## MOVEMENT ALARM

If set and activated, the alarm will be triggered by any movement of the device, including knocking over the device. The alarm will sound and the device will strobe red for the amount of time that was set in the “Alarm Time” setting, but will automatically stop when the device is returned to its place. Please be aware of this feature in the event that you decide to re-locate or re-position the device after the initial setup!

# INSTALLATION GUIDELINES

## RIGGING

Overhead rigging requires extensive experience, including among others, calculating working load limits, installation material being used, and periodic safety inspection of all installation material and the fixture. If you lack these qualifications, do not attempt the installation yourself. Improper installation can result in bodily injury.

This fixture is designed to be mounted vertically (hanging or upright), or horizontally (perpendicular to vertical axis) only.

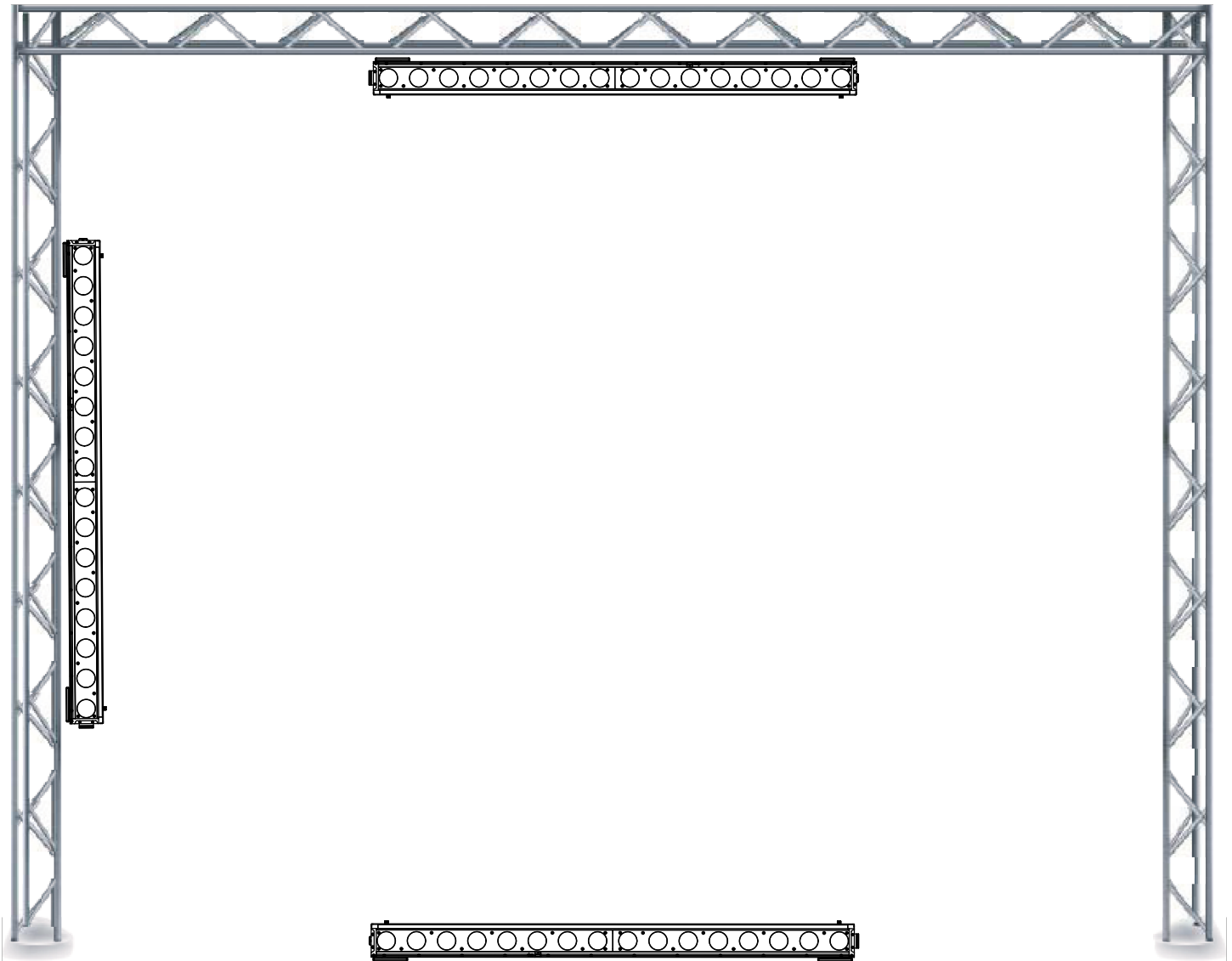

**FALLING FIXTURES CAN CAUSE SEVERE INJURY OR SERIOUS EQUIPMENT DAMAGE! FOR THIS REASON, FIXTURES SHOULD BE INSTALLED AND INSPECTED ONLY BY QUALIFIED PERSONNEL. DO NOT INSTALL THE UNIT IF YOU LACK THE QUALIFICATIONS TO DO SO, OR IF YOU HAVE DOUBTS ABOUT THE SAFETY AND SECURITY OF THE INSTALLATION SETUP OR LOCATION!**



**ALWAYS ATTACH A SAFETY CABLE WHENEVER INSTALLING THIS FIXTURE IN A SUSPENDED ENVIRONMENT TO ENSURE THE FIXTURE WILL NOT FALL IF THE CLAMP FAILS.**

# INSTALLATION GUIDELINES

## POTENTIAL INTERNAL FIXTURE DAMAGE FROM EXTERNAL SOURCES OF LIGHT BEAMS

External sources of light beams from direct sunlight, lighting and moving head fixtures, and lasers, which are focused directly towards the exterior housing and/or penetrate the front lens opening of Elation lighting fixtures, can cause severe internal damage including burning of optics, dichroic color filters, glass and metal gobos, prisms, animation wheels, frost filters, iris, shutters, motors, belts, wiring, discharge lamps, and LEDs.

This issue is not specific only to Elation lighting fixtures, but rather it is a common issue with lighting fixtures from all manufacturers. Although there is no true way to fully prevent this issue from happening, the guidelines below can reduce the risk of potential damage. Contact Elation Service for more details.

**DO NOT EXPOSE THE FIXTURE AND/OR FRONT LENS OPENING TO LIGHT BEAMS FROM DIRECT SUNLIGHT, OTHER LIGHTING OR MOVING HEAD FIXTURES, AND LASERS DURING UNPACKING, INSTALLATION, USE, AND EXTENDED IDLE TIMES OUTDOORS. DO NOT FOCUS A LIGHT BEAM FROM ONE LIGHTING FIXTURE DIRECTLY TOWARDS ANOTHER.**

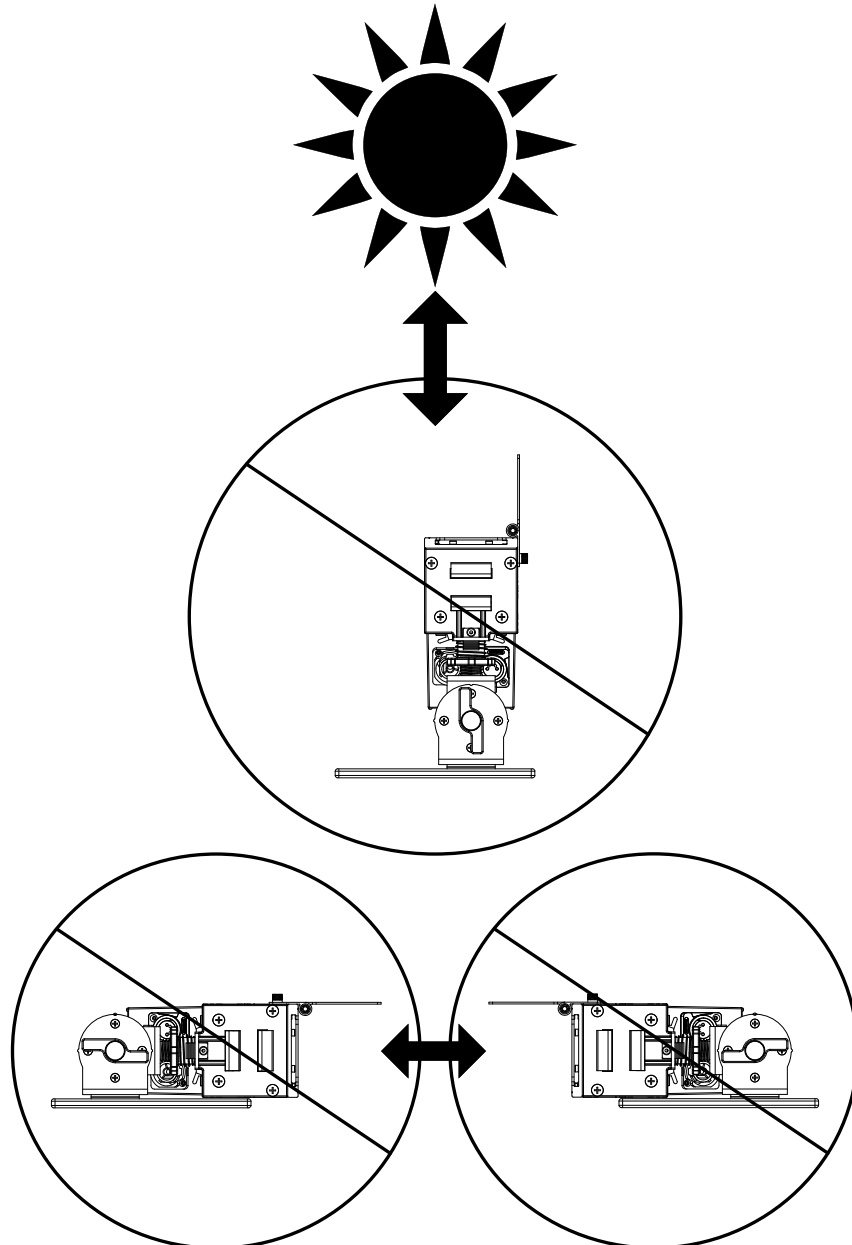

## ACCESSORY INSTALLATION: FROST FILTER

Locate Frost Filter Lens Lock and press out to unlock it. Carefully slide Frost Filter Lens into the Lens Slots. Once in place, secure the Frost Filter Lens by pressing inward to relock it.

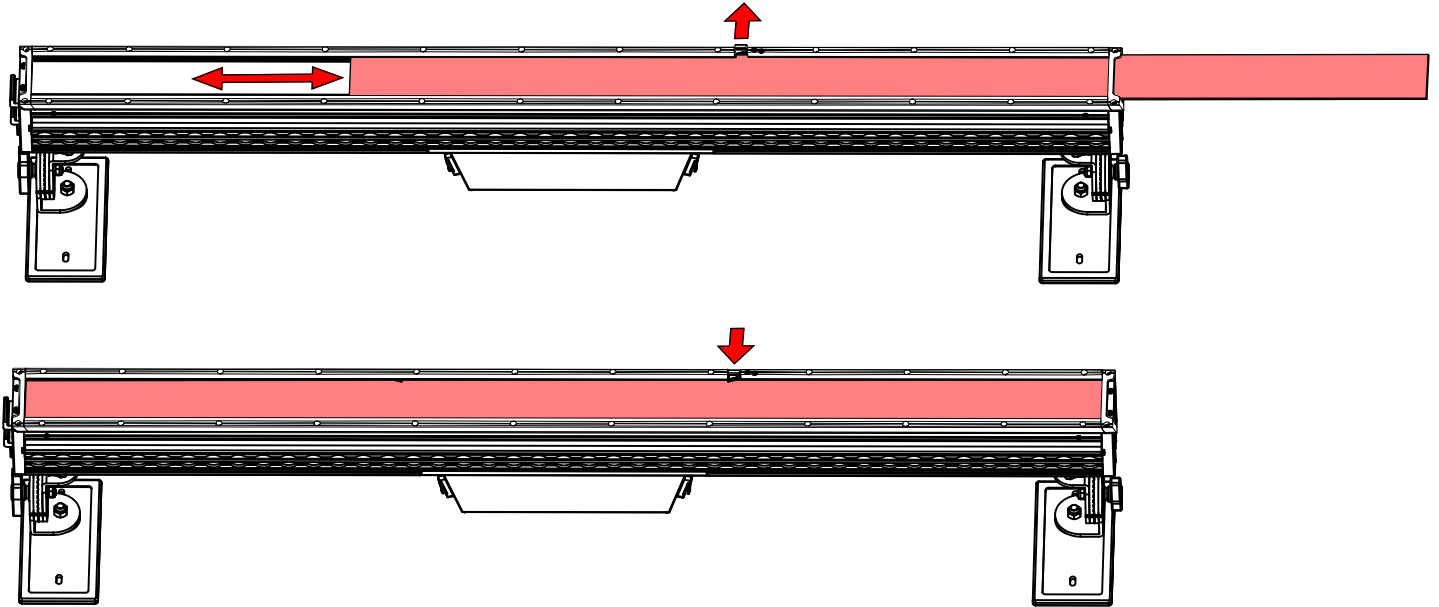

# ACCESSORY INSTALLATION - GLARE SHIELD

1. Locate 2 Glare Shield mounting screw holes on either side of fixture.

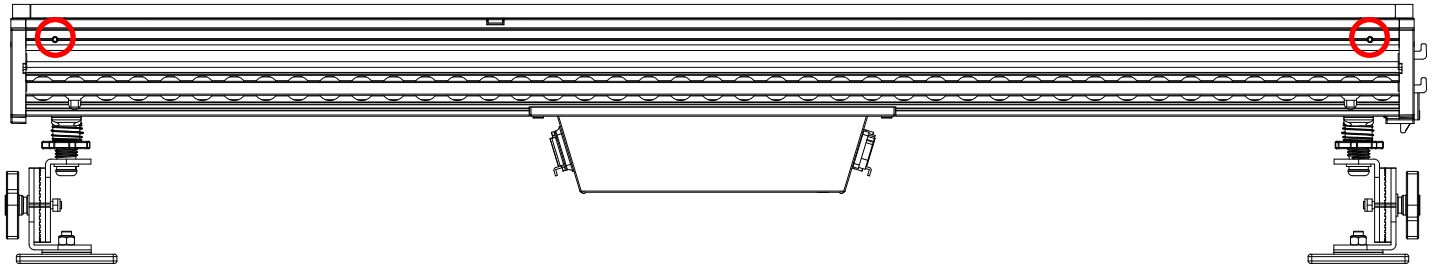

2. Align the thumbscrews of the Glare Shield with the mounting screw holes and insert them.

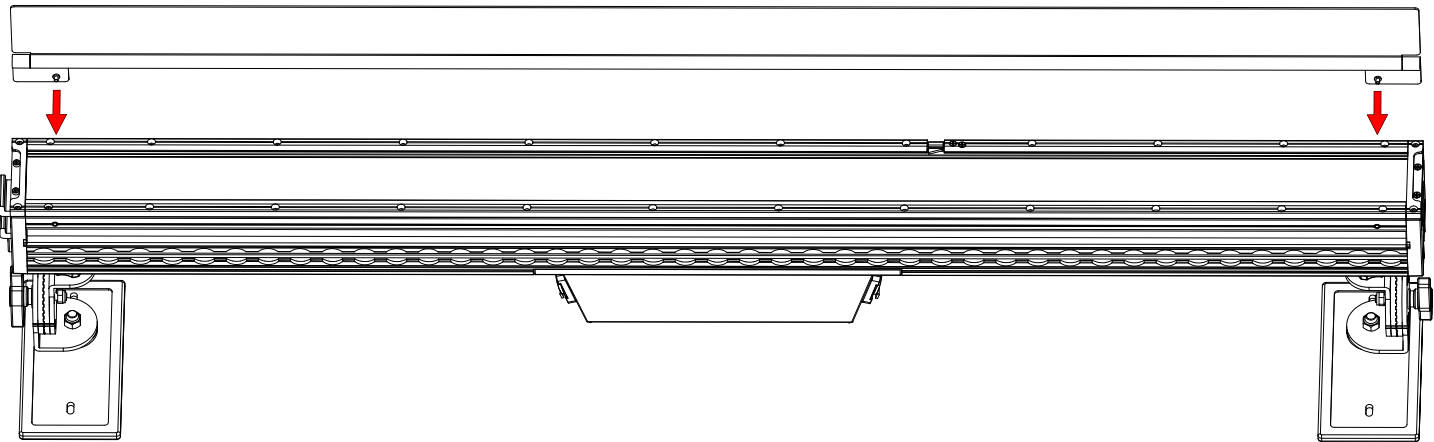

3. Tighten the two thumbscrews to secure Glare Shield. Thumbscrews can also be tightened with a Phillips screw driver.

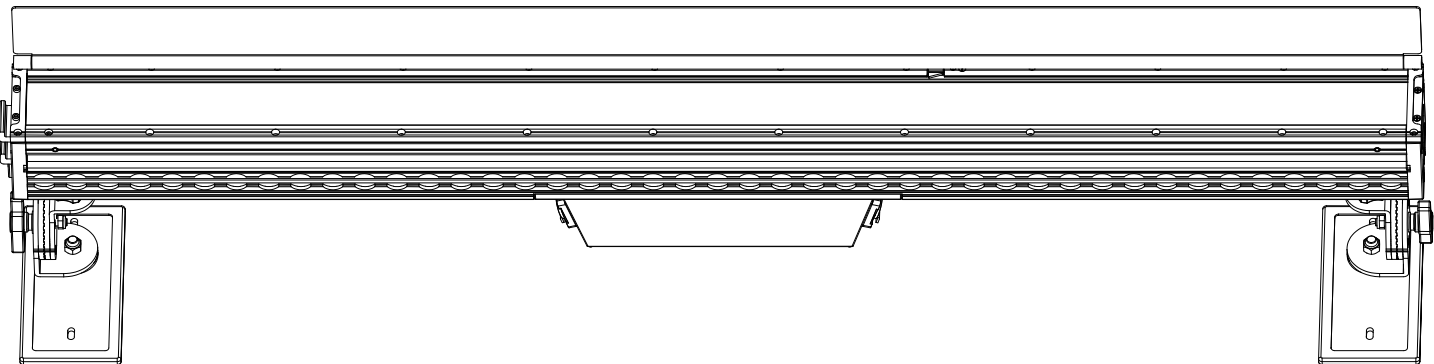

# ACCESSORY INSTALLATION - L-TRACK

## L-TRACK MOUNTING

This unit's L-track mounting system allows the user to slide the mounting clamps along the tracks and lock them down in the desired position. This unit features two L-tracks mounted on the underside of the unit and two along the sides of the unit. These L-tracks are fitted with mounting brackets from the factory, but the brackets may be detached and other L-track components can be installed in their place. Special L-track mounting clamps, which incorporate an L-track attachment rail in place of a mounting bolt hole, are available in both regular and extended lengths. Similarly, L-track adapters are also available which can be fitted to any standard mounting clamp.

To attach an L-track clamp or adapter, simply insert the attachment rail into the matching track on the fixture, slide to its desired location, and tighten the fastener knob on the attachment to secure in place.

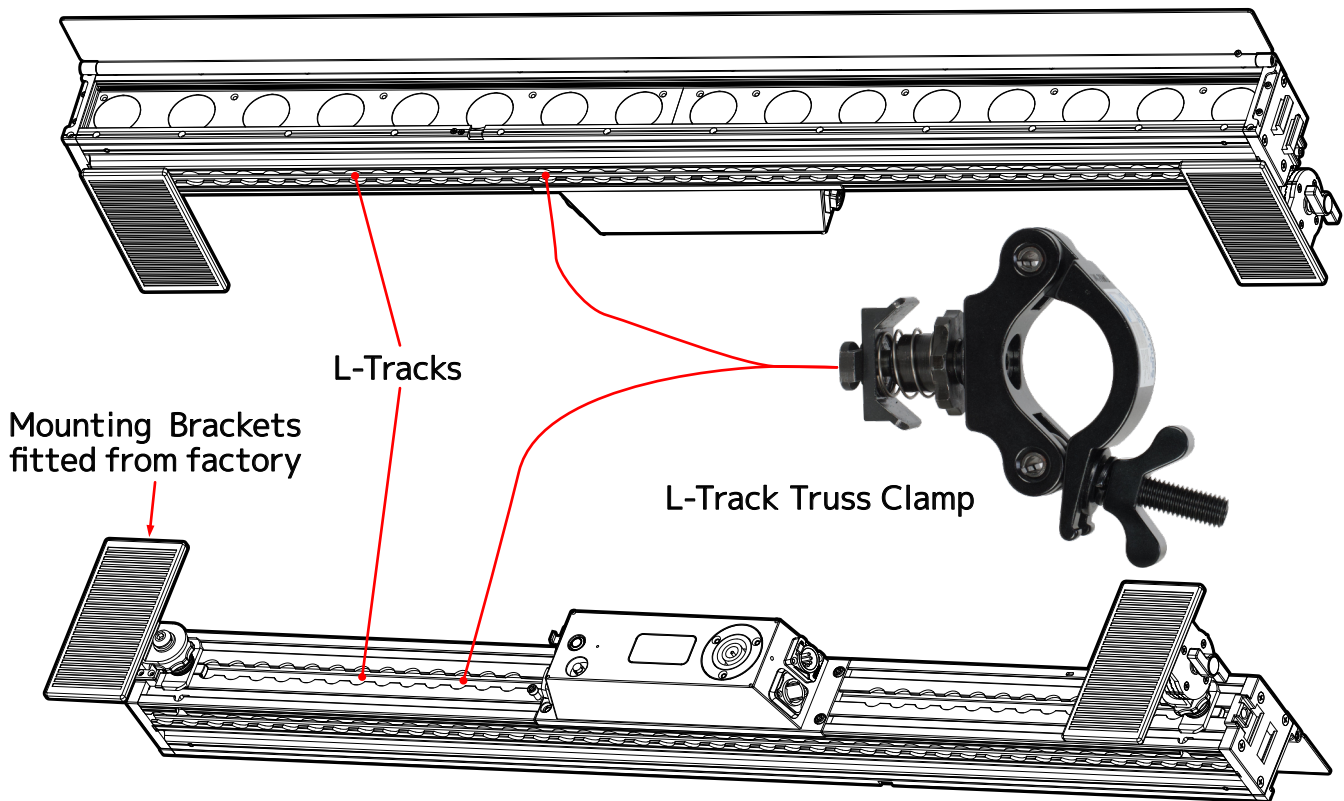

# ACCESSORY INSTALLATION - VFB1 FLOOR BASE

## VFB1 FLOOR BASE: MOUNTING & STACKING

To mount the ElectraPix BAR 16 fixture to the VFB1 Floor Base, align the connector recesses located at one end of the fixture with the bars on the VFB1 Floor Base. This fixture features two L-tracks mounted along the sides of the unit to mount and secure the ElectraPix BAR 16 fixture into the VFB1 Floor Base.

**NOTE: A MAXIMUM OF TWO (2X) ELECTRAPIX BAR 16 FIXTURES CAN BE SAFELY STACKED ON THE VFB1 FLOOR BASE.**

To stack an ElectraPix BAR 16 fixture on another ElectraPix BAR 16 fixture, align the Connector Recesses with the Connector Lock Tabs, depress the Knurled Post-Lock Tab, hook the Connector Tabs into the shelved Connector Recesses until the fixtures are flush, then release the knurled Post-Lock Tab to lock it into place.

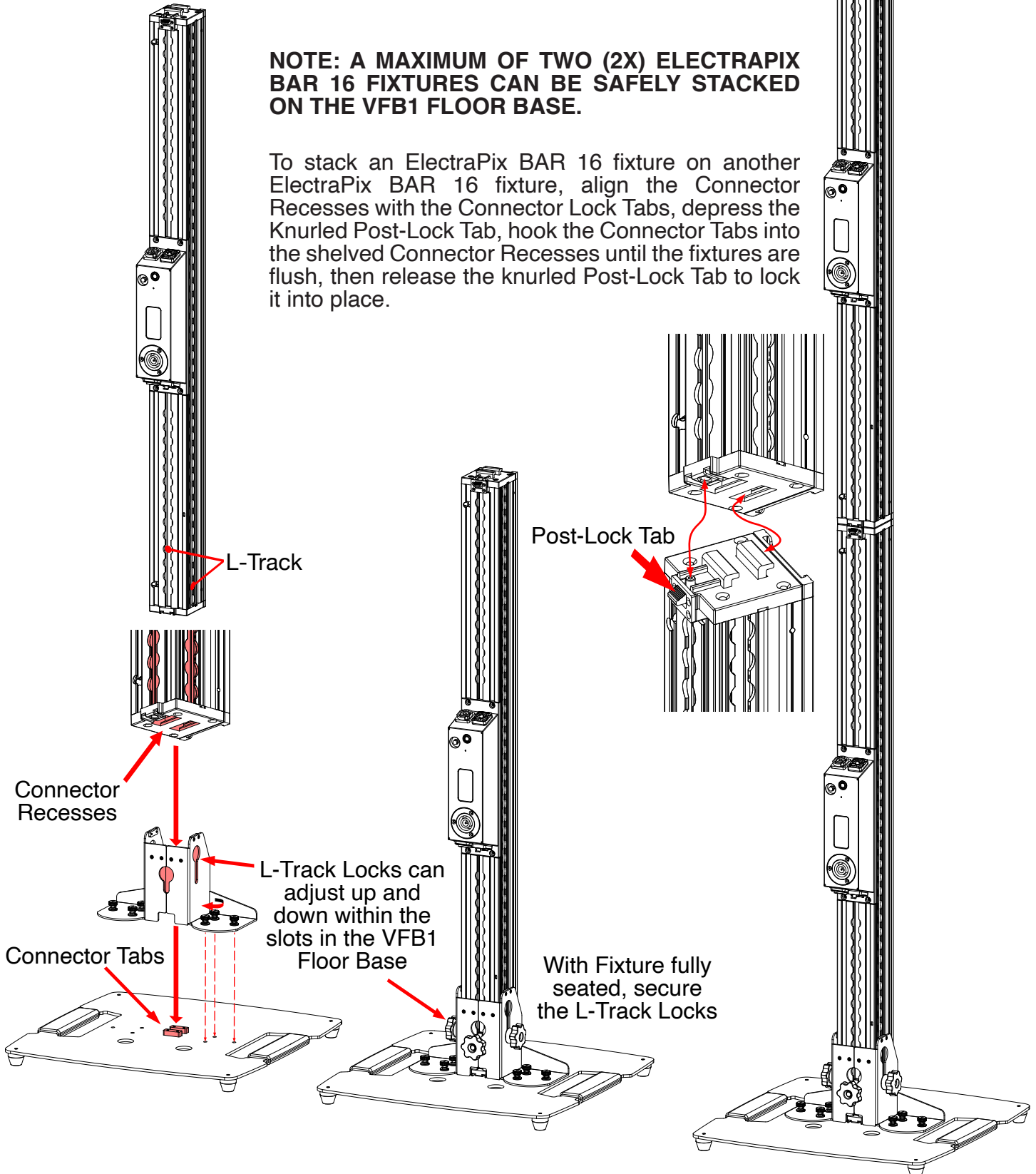

# ACCESSORY INSTALLATION - BATTERY CHARGER

To charge the internal battery, carefully plug the Charging Base into the Charge Port, located on the bottom of the fixture next to the control panel, and plug the Power Supply into the Charging Base. If the battery is completely discharged, Charge Time is 5.5-hours for a full charge.

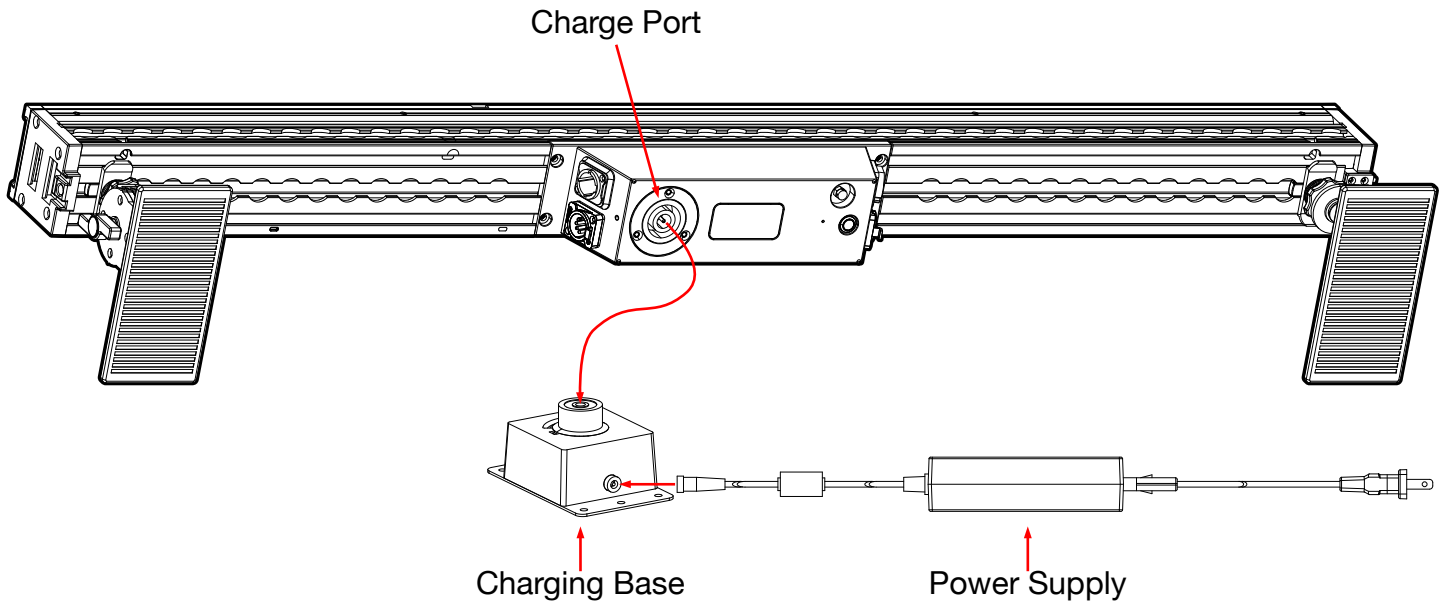

**Disconnect the unit from the charger once the battery is fully charged.** Doing so reduces the risk of overcharging the battery, which can shorten the service life of the battery.

**Note that the charging components are NOT protected against the intrusion of dust and/or water, and are intended for use only in a dry indoor environment. Do NOT expose to rain or moisture. When charging is complete, always seal the charging port with the included plug to maintain the fixture's IP rating.**

# SYSTEM MENU

This unit features a display screen with a 4-button control pad, which can be used to easily adjust any device settings.

Pressing the **MODE** button will cycle through the various Main Menu options. When the desired Main Menu option is displayed on the screen, press the **SETUP** button to enter the sub-menu, then use the **UP** and **DOWN** buttons to scroll through sub-menu options. In some cases, there will be a second sub-menu that can be navigated in the same way.

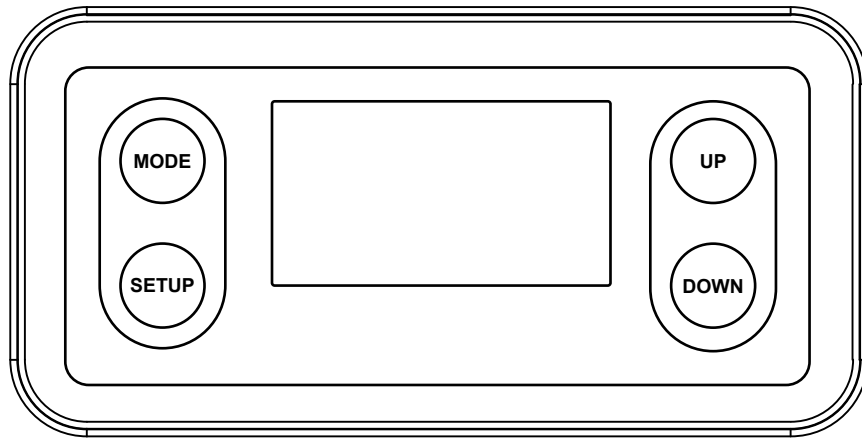

This fixture includes a display lock feature which automatically shuts off the display screen after a certain period of inactivity. This feature is OFF by default, which means that the display will always remain on regardless of inactivity, but can be configured to kick in after up to 10 minutes of inactivity.

# SYSTEM MENU - ENGLISH

| MAIN MENU           | OPTIONS / VALUES (Default Settings in <b>BOLD</b> )                                   |   |                                      |         |
|---------------------|---|---|--------------------------------------|---------|
| <b>DMX Settings</b> | DMX Address   | <b>001</b> - 512  |                                      |         |
|                     | DMX Mode  | 5ch, 6ch, 7ch, 9ch, 12ch, 13ch, <b>22ch</b> , 24ch, 96ch, 99ch, 114ch |                                      |         |
|                     | No DMX Status   | <b>Hold Last</b> , Blackout, Manual Settings, Internal Programs       |                                      |         |
| <b>Personality</b>  | Prim/Sec Mode   | Primary, <b>Secondary</b>   |                                      |         |
|                     | Select Signal   | <b>DMX</b> or Aria  |                                      |         |
|                     |   | Enable Aria in and Physical DMX Out                                   | ON/OFF                               |         |
|                     |   | Enable DMX In and Aria Out  | ON/OFF                               |         |
|                     | Aria Settings   | Enable Aria   | ON/OFF                               |         |
|                     |   | Frequency   | <b>2.4 GHz</b> / Sub-G US / Sub-G EU |         |
|                     |   | Set Aria 2.4Ghz channel   | <b>00</b> ~15                        |         |
|                     |   | Sub-G Ch  | <b>00</b> ~09                        |         |
|                     |   | Mesh  | <b>ON</b> / OFF                      |         |
|                     |   | Bluetooth Enable  | ON/OFF                               |         |
|                     | RDM   | ON/OFF  |                                      |         |
|                     | Dim Modes   | <b>Standard</b> , Stage, TV, Architectural, Theatre, Stage 2          |                                      |         |
|                     |   | Dim Speed   | 0-99                                 |         |
|                     | Dim Curve   | <b>Square</b> , Linear, Inv.Squa, S.Curve                             |                                      |         |
|                     | IR Function   | ON / OFF  |                                      |         |
|                     | IR Button Colors  | Button 0  | Red                                  | 000-255 |
|                     |   |   | Green                                | 000-255 |
|                     |   |   | Blue                                 | 000-255 |
|                     |   |   | Amber                                | 000-255 |
|                     |   |   | Lime                                 | 000-255 |
|                     |   |   | UV                                   | 000-255 |
|                     |   | Button 1  | Red                                  | 000-255 |
|                     |   |   | Green                                | 000-255 |
|                     |   |   | Blue                                 | 000-255 |
|                     |   |   | Amber                                | 000-255 |
|                     |   |   | Lime                                 | 000-255 |
|                     |   |   | UV                                   | 000-255 |
|                     |   | Button 2  | Red                                  | 000-255 |
| Green               |   |   | 000-255                              |         |
| Blue                |   |   | 000-255                              |         |
| Amber               |   |   | 000-255                              |         |
| Lime                |   |   | 000-255                              |         |
| UV                  |   |   | 000-255                              |         |
| ...                 |   | ...   | ...                                  |         |
| Button 15           |   | Red   | 000-255                              |         |
|                     |   | Green   | 000-255                              |         |
|                     |   | Blue  | 000-255                              |         |
|                     |   | Amber   | 000-255                              |         |
|                     |   | Lime  | 000-255                              |         |
|                     | UV  | 000-255   |                                      |         |
| Pixel Flip          | <b>Pixel Flip 1</b> , Pixel Flip 2  |   |                                      |         |
| LED Refresh Rate    | 900, 1000, 1100, <b>1200</b> , 1300, 1400, 1500, 2500, 4000, 5000, 10k, 15k, 20k, 25k |   |                                      |         |
| Display             | Screen Saver Delay  | OFF, 1- <b>10</b> seconds   |                                      |         |
|                     | Touch Screen Lock   | OFF - <b>30 seconds</b> , 1 minute                                    |                                      |         |
|                     | Rotate Display 180°   | <b>YES</b> / NO   |                                      |         |
| Language            | Passcode  | <b>English</b> , Spanish  |                                      |         |
| Alarm               | Passcode  | ON / OFF  |                                      |         |
|                     | Alarm Time  | <b>10s</b> , 20s, 30s, 40s, 60s                                       |                                      |         |

# SYSTEM MENU - ENGLISH

| MAIN MENU                          |                             | OPTIONS / VALUES (Default Settings in <b>BOLD</b> ) |                   |                         |
|------------------------------------|-----------------------------|---|-------------------|-------------------------|
| <b>Personality<br/>(continued)</b> | Service                     | Passcode  | White Balance     | Red 000-255             |
|                                    |                             |   |                   | Green 000-255           |
|                                    |                             |   |                   | Blue 000-255            |
|                                    |                             |   |                   | Amber 000-255           |
|                                    |                             |   |                   | Lime 000-255            |
|                                    |                             |   |                   | UV 000-255              |
|                                    |                             |   | Color Calibration | <b>Enable / Disable</b> |
|                                    |                             |   | DMX Indicators    | Enable / <b>Disable</b> |
| Charging Indicator                 | Enable / <b>Disable</b>     |   |                   |                         |
| Factory Restore                    | <b>YES / NO</b>             |   |                   |                         |
| <b>Manual<br/>Control</b>          | Red                         | 000-255   |                   |                         |
|                                    | Green                       | 000-255   |                   |                         |
|                                    | Blue                        | 000-255   |                   |                         |
|                                    | Amber                       | 000-255   |                   |                         |
|                                    | Lime                        | 000-255   |                   |                         |
|                                    | UV                          | 000-255   |                   |                         |
|                                    | RGBAL+UV Color Macros       | <b>000-064</b>                                      |                   |                         |
|                                    | Background Red              | <b>000-255</b>                                      |                   |                         |
|                                    | Background Green            | <b>000-255</b>                                      |                   |                         |
|                                    | Background Blue             | <b>000-255</b>                                      |                   |                         |
|                                    | RGB Background Color Macros | <b>000-255</b>                                      |                   |                         |
|                                    | Color Temperature Linear    | <b>No Function, 2300K - 9900K</b>                   |                   |                         |
|                                    | Color Temp Presets          | <b>No Function, 2300K, 2400K... 9900K</b>           |                   |                         |
|                                    | Shutter                     | <b>000-255</b>                                      |                   |                         |
|                                    | Dimmer                      | <b>000-255</b>                                      |                   |                         |
|                                    | Internal Programs           | <b>Off, Prog 0, Prog 1... Prog 13</b>               |                   |                         |
|                                    | Internal Programs Speed     | <b>000-255</b>                                      | 1-255             | <b>127</b>              |
|                                    | Internal Programs Fade      | <b>000-255</b>                                      | 0-255             | <b>0</b>                |
| RGB Background Programs            | <b>000-255</b>              |   |                   |                         |
| RGB Background Programs Speed      | <b>000-255</b>              |   |                   |                         |
| RGB Background Programs Fade       | <b>000-255</b>              |   |                   |                         |
| <b>Internal<br/>Programs</b>       | Program 0                   | Speed   | 0-255             | 127                     |
|                                    |                             | Fade  | 0-255             | 0                       |
|                                    | Program 1                   | Speed   | 0-255             | 127                     |
|                                    |                             | Fade  | 0-255             | 0                       |
|                                    | Program 2                   | Speed   | 0-255             | 127                     |
|                                    |                             | Fade  | 0-255             | 0                       |
|                                    | Program 3                   | Speed   | 0-255             | 127                     |
|                                    |                             | Fade  | 0-255             | 0                       |
|                                    | ...                         | ...   | ...               | ...                     |
|                                    | Program 13                  | Speed   | 0-255             | 127                     |
| Fade                               |                             | 0-255   | 0                 |                         |
| <b>Information</b>                 | LED Temperature             | xxx F / xxx C                                       |                   |                         |
|                                    | Software Version            | x.xx  |                   |                         |
|                                    | RDM UID                     | xxxxxx  |                   |                         |
| <b>Battery</b>                     | Charging Time               | xx hours  |                   |                         |
|                                    | Current Life                | xxx%  |                   |                         |
|                                    | Operation Mode              | <b>5 Hr ~ 20 Hr</b>                                 |                   |                         |

# SYSTEM MENU - SPANISH

| MENU PRINCIPAL                     | OPCIONES / VALORES (Configuración predeterminada en <b>NEGRITA</b> )                  |  |                                    |                        |
|------------------------------------|---|--|------------------------------------|------------------------|
| <b>Configuración DMX</b>           | Dirección DMX   | <b>001 - 512</b>   |                                    |                        |
|                                    | Modo Canales DMX  | 5ch, 6ch, 7ch, 9ch, 12ch, 13ch, <b>22ch</b> , 24ch, 96ch, 99ch, 114ch  |                                    |                        |
|                                    | Estado DMX  | <b>TENER ULTIMO</b> , Apagón, Configuración Manual, Programas Internos |                                    |                        |
| <b>Persinalidad</b>                | Primario / Secundario   | <b>ON / OFF</b>  |                                    |                        |
|                                    | Activar la Señal  | <b>DMX</b> o Aria  |                                    |                        |
|                                    |   | Activar Aria In y DMX Out  | <b>ON/OFF</b>                      |                        |
|                                    |   | Activar DMX In y Aria Out  | <b>ON/OFF</b>                      |                        |
|                                    | Aria Settings   | Activar Aria   |                                    | <b>ON/OFF</b>          |
|                                    |   | Eligir la banda de radio Aria  |                                    | 2.4Ghz / <b>900Mhz</b> |
|                                    |   | Eligir el canal Aria 2.4Ghz  |                                    | <b>00~15</b>           |
|                                    |   | Eligir el canal Aria 900Mhz  |                                    | <b>00~25</b>           |
|                                    |   | Activar Bluetooth  |                                    | <b>ON/OFF</b>          |
|                                    | RDM   | <b>ON/OFF</b>  |                                    |                        |
|                                    | Modos de Atenuación   | <b>Estándar</b> , Estándar, TV, Architectural, Teatro, Escenario 2     |                                    |                        |
|                                    |   | Retardo de Atenuación  | <b>0-99</b>                        |                        |
|                                    | Curva de Atenuación   | <b>Cuadrado</b> , Lineal, Inv.Squa, S.Curve                            |                                    |                        |
|                                    | Función de IR   | <b>ON / OFF</b>  |                                    |                        |
|                                    | Colores del botón de control IR   | Botone 0   | Rojo                               | 000-255                |
|                                    |   |  | Verde                              | 000-255                |
|                                    |   |  | Azul                               | 000-255                |
|                                    |   |  | Ámbar                              | 000-255                |
|                                    |   |  | Lima                               | 000-255                |
|                                    |   |  | UV                                 | 000-255                |
|                                    |   | Botone 1   | Rojo                               | 000-255                |
|                                    |   |  | Verde                              | 000-255                |
|                                    |   |  | Azul                               | 000-255                |
|                                    |   |  | Ámbar                              | 000-255                |
|                                    |   |  | Lima                               | 000-255                |
|                                    |   | Botone 2   | Rojo                               | 000-255                |
|                                    |   |  | Verde                              | 000-255                |
|                                    |   |  | Azul                               | 000-255                |
| Ámbar                              |   |  | 000-255                            |                        |
| Lima                               |   |  | 000-255                            |                        |
| ...                                |   | ...  | ...                                |                        |
| Botone 15                          |   | Rojo   | 000-255                            |                        |
|                                    |   | Verde  | 000-255                            |                        |
|                                    |   | Azul   | 000-255                            |                        |
|                                    |   | Ámbar  | 000-255                            |                        |
|                                    | Lima  | 000-255  |                                    |                        |
| UV                                 | 000-255   |  |                                    |                        |
| Inversión de Píxeles               | <b>Inversión 1</b> , Inversión 2  |  |                                    |                        |
| Frecuencia de actualización de LED | 900, 1000, 1100, <b>1200</b> , 1300, 1400, 1500, 2500, 4000, 5000, 10k, 15k, 20k, 25k |  |                                    |                        |
| Monitor                            | Retraso del protector de pantalla   |  | <b>OFF</b> , 1- <b>10</b> segundos |                        |
|                                    | Bloqueo de pantalla táctil  |  | <b>OFF</b> - 10 minutos            |                        |
|                                    | Girar la pantalla 180°  |  | <b>YES / NO</b>                    |                        |
| Idioma                             | Código de acceso  | <b>English</b> , Español   |                                    |                        |
| Alarma                             | Código de acceso  |  | <b>ON / OFF</b>                    |                        |
|                                    | Tiempo de sonido  |  | <b>10s</b> , 20s, 30s, 40s, 60s    |                        |

# SYSTEM MENU - SPANISH

| MENU PRINCIPAL                               | OPCIONES / VALORES (Configuración predeterminada en <b>NEGRITA</b> ) |                  |  |                             |
|--|--|------------------|--|-----------------------------|
| Persinalidad (continúa)                      | Servicio   | Codigo de acceso | Ajuste de colores                                | Rojo 000-255                |
|  |  |                  |  | Verde 000-255               |
|  |  |                  |  | Azul 000-255                |
|  |  |                  |  | Ambar 000-255               |
|  |  |                  |  | Lima 000-255                |
|  |  |                  |  | UV 000-255                  |
|  |  |                  | Calibración de color                             | <b>Activar</b> o Desactivar |
|  |  |                  | Indicadores DMX                                  | Activar o <b>Desactivar</b> |
| Indicador de carga                           | Activar o <b>Desactivar</b>  |                  |  |                             |
| Restauracion de fabrica                      | <b>YES / NO</b>  |                  |  |                             |
| Manual Control                               | Rojo   |                  | 000-255  |                             |
|  | Verde  |                  | 000-255  |                             |
|  | Azul   |                  | 000-255  |                             |
|  | Ambar  |                  | 000-255  |                             |
|  | Lima   |                  | 000-255  |                             |
|  | UV   |                  | 000-255  |                             |
|  | RGBAL+UV Macro de color  |                  | <b>000-255</b>                                   |                             |
|  | Fondo Rojo   |                  | <b>000-255</b>                                   |                             |
|  | Fondo Verde  |                  | <b>000-255</b>                                   |                             |
|  | Fondo Azul   |                  | <b>000-255</b>                                   |                             |
|  | Macros de Color de Fondo RGB   |                  | <b>000-255</b>                                   |                             |
|  | Temperatura de Color 2300-9900K Lineal                               |                  | <b>000-255</b>                                   |                             |
|  | Preajustes de Temperatura de Color                                   |                  | <b>Off</b> , 2300k, 2400k, 2500k, 2600k... 9900k |                             |
|  | Estrobo  |                  | <b>000-255</b>                                   |                             |
|  | Dimmer Principar   |                  | <b>000-255</b>                                   |                             |
|  | Programas de fondo RGB   |                  | <b>000-255</b>                                   |                             |
| Velocidad de Programas de Fondo RGB          |  | <b>000-255</b>   |  |                             |
| Tiempo de transición Programas de Fondo RGB. |  | <b>000-255</b>   |  |                             |
| Programas Internos                           | Programa 0   | Velocidad        | 1-255  | 127                         |
|  |  | Descolorarse     | 0-255  | 0                           |
|  | Programa 1   | Velocidad        | 1-255  | 127                         |
|  |  | Descolorarse     | 0-255  | 0                           |
|  | Programa 2   | Velocidad        | 1-255  | 127                         |
|  |  | Descolorarse     | 0-255  | 0                           |
|  | Programa 3   | Velocidad        | 1-255  | 127                         |
|  |  | Descolorarse     | 0-255  | 0                           |
| ...  | ...  | ...              | ...  |                             |
| Programa 13                                  | Velocidad  | 1-255            | 127  |                             |
|  | Descolorarse   | 0-255            | 0  |                             |
| Informacion                                  | Temperatura de los LED's   |                  | xxx F / xxx C                                    |                             |
|  | Version de software  |                  | x.xx   |                             |
|  | RDM UID  |                  | xxxxxx   |                             |
| Bateria                                      | Tiempo de carga  |                  | xx horas   |                             |
|  | Cargar   |                  | xxx%   |                             |
|  | Modos de operacion   |                  | <b>5 Hr ~ 20 Hr</b>                              |                             |

# DIMMER MODES AND CURVES

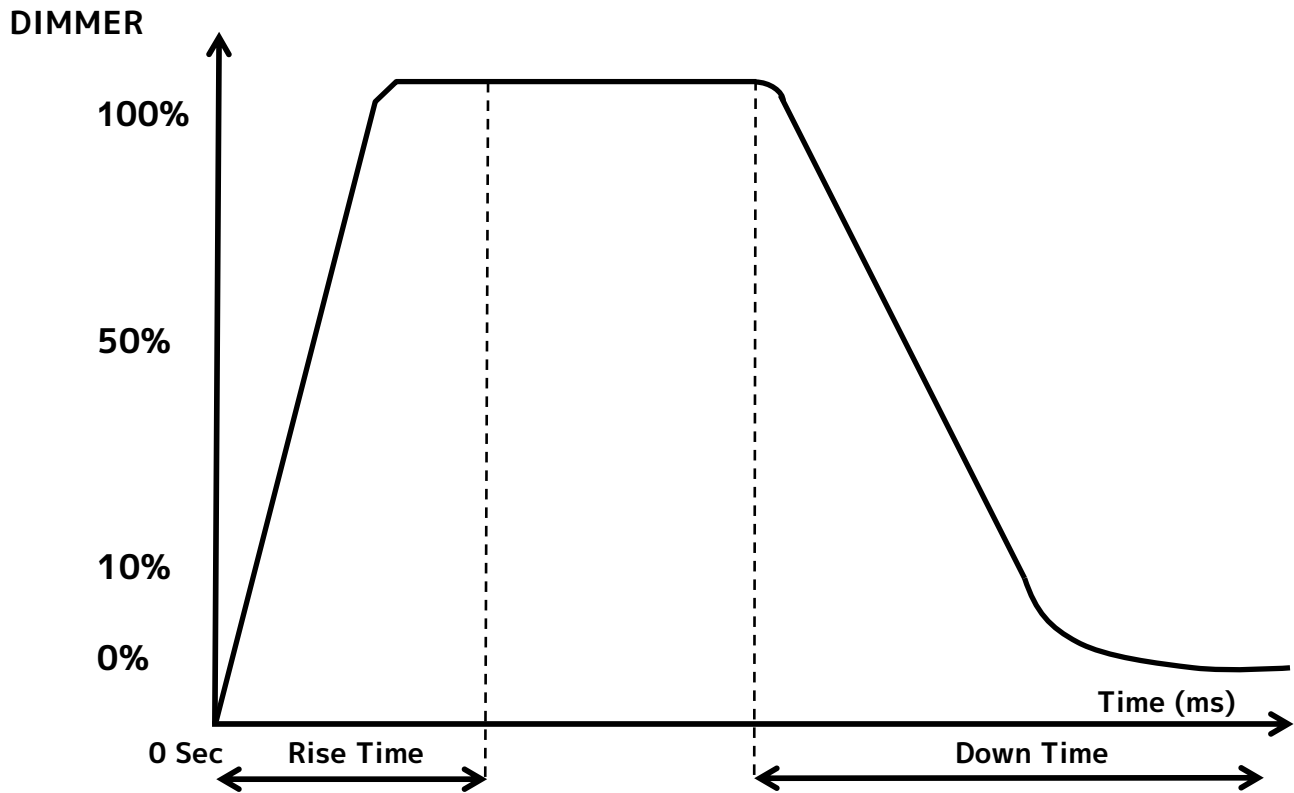

| Dimming Curve<br>Ramp Effect | 0 sec Fade Time |                | 1 sec Fade Time |                |
|------------------------------|-----------------|----------------|-----------------|----------------|
|                              | Rise Time (ms)  | Down Time (ms) | Rise Time (ms)  | Down Time (ms) |
| Standard (default)           | 0               | 0              | 0               | 0              |
| Stage                        | 780             | 1100           | 1540            | 1660           |
| TV                           | 1180            | 1520           | 1860            | 1940           |
| Architectural                | 1380            | 1730           | 2040            | 2120           |
| Theatre                      | 1580            | 1940           | 2230            | 2280           |
| Stage 2                      | 0               | 1100           | 0               | 1660           |

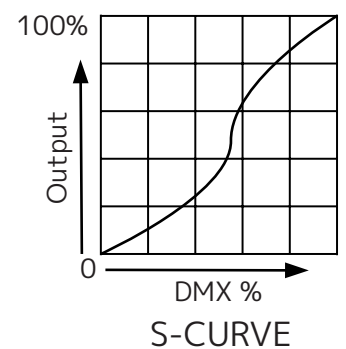
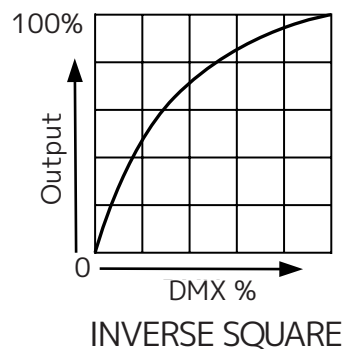
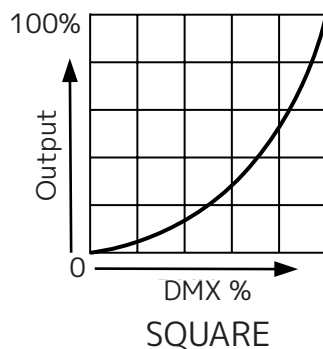
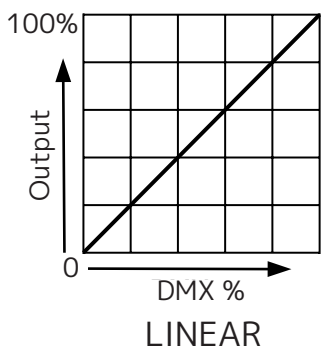

# REMOTE CONTROL GUIDELINES

## REMOTE FUNCTIONS

The functions available on the ADJ UC IR24 remote unit are detailed below:

- **ON:** Activates the fixture.
- **OFF:** Fixture goes into stand by mode in a blackout state.
- **STROBE:** Fixture strobes the most recently selected color or program. Strobe rate can be adjusted by degrees using the + / - buttons, or preset strobe speeds can directly be selected using number keys 1-15. 1 is the slowest flash speed, and 15 is the fastest.
- **SOUND:** The fixture responds to microphone inputs with the most recently selected program. Microphone sensitivity can then be adjusted using the +/- buttons.
- **COLOR:** Activates color mode. Preset static colors can now be selected by using the number keys 0-15. The intensity for the set color can then be adjusted using the +/- buttons.
- **PROGRAM:** Activates program mode. Internal programs can be selected by using the number keys 0-13. The selected program run speed can be adjusted with the +/- buttons.
- **+ and - buttons:** These buttons are used to increase/decrease strobe rate when the STROBE button is active, increase/decrease mic sensitivity when the SOUND button is active, increase/decrease brightness intensity when the COLOR button is active, and increase/decrease program run speed when the PROGRAM button is active. The +/- buttons can be repeatedly pressed to make adjustments in single-step increments, or they can be pressed and held down to quickly scroll to the desired value.
- **0-15 buttons:** These buttons are used to select preset strobe speeds when the STROBE button is active, to select preset static colors when the COLOR button is active, and to select internal programs when the PROGRAM button is active. Colors stored in buttons 0-15 can be edited from the units menu if desired by the user.



# IR DEFAULT VALUES

| BUTTON | RED | GREEN | BLUE | AMBER |
|--------|-----|-------|------|-------|
| 0      | 255 | 255   | 255  | 255   |
| 1      | 255 | 0     | 0    | 0     |
| 2      | 0   | 255   | 0    | 0     |
| 3      | 0   | 0     | 255  | 0     |
| 4      | 255 | 46    | 0    | 0     |
| 5      | 0   | 255   | 28   | 0     |
| 6      | 17  | 0     | 75   | 0     |
| 7      | 255 | 83    | 0    | 63    |
| 8      | 0   | 255   | 52   | 0     |
| 9      | 32  | 0     | 75   | 22    |
| 10     | 0   | 0     | 0    | 255   |
| 11     | 0   | 114   | 160  | 0     |
| 12     | 100 | 0     | 97   | 0     |
| 13     | 255 | 255   | 0    | 255   |
| 14     | 0   | 75    | 136  | 0     |
| 15     | 146 | 0     | 80   | 0     |

## EDITING IR BUTTON VALUES

These fixtures allow the user to create custom RGBA values and assign them to the numbered keys (0-15) on the remote control. Follow the steps below:

1. In the main system menu, press MODE to navigate to “Personality,” then press ENTER. Use the UP and DOWN buttons to scroll to “IR Button Colors,” then press ENTER again.
2. Use the UP and DOWN buttons to scroll to the number of the remote button that you would like to use. Options range from “Button 0” to “Button 15.” Press ENTER to select the button shown on the display screen.
3. Create a custom color for the button you have selected by using the UP and DOWN buttons to scroll through the color component options (Red, Green, Blue, Amber, Lime). Press ENTER to select a color component option, then use the UP and DOWN buttons to adjust the intensity of that color component option. Selectable values range from 000 to 255. Repeat this process until you have set the desired Red, Green, Blue, and Amber intensities to create your custom color.

**NOTE:** Once you have created and assigned a custom RGBA value to a remote button, the default color for the remote button will be overridden. This means that the output color of the fixture may no longer resemble the color shown on the remote button. The only way to return to the default RGBA value is to reset the unit to the default factory settings by navigating to **Personality > Service > Factory Restore**.

**NOTE:** If multiple units have been linked in a primary-secondary set up, the custom RGBA values only need to be set up on the primary unit. The custom RGBA settings will carry over automatically to any secondary units in the system.

# DMX SETUP

**DMX-512:** DMX is short for Digital Multiplex. This is a universal protocol used as a form of communication between intelligent fixtures and controllers. A DMX controller sends DMX data instructions from the controller to the fixture. DMX data is sent as serial data that travels from fixture to fixture via the DATA “IN” and DATA “OUT” XLR terminals located on all DMX fixtures (most controllers only have a DATA “OUT” terminal).

**DMX Linking:** DMX is a language allowing all makes and models of different manufacturers to be linked together and operate from a single controller, as long as all fixtures and the controller are DMX compliant. To ensure proper DMX data transmission, try to use the shortest cable path possible when using several DMX fixtures. The order in which fixtures are connected in a DMX line does not influence the DMX addressing. For example, a fixture assigned a DMX address of 1 may be placed anywhere in a DMX line: at the beginning, at the end, or anywhere in the middle. When a fixture is assigned a DMX address of 1, the DMX controller knows to send DATA assigned to address 1 to that unit, no matter where it is located in the DMX chain.

**Data Cable (DMX Cable) Requirements (For DMX Operation):**The Jolt Panel FX can be controlled via DMX-512 protocol, and features multiple DMX channel modes. Your unit and your DMX controller require a 5-pin XLR connector for data input and data output. If you are making your own cables, be sure to use standard 110-120 Ohm shielded cable (This cable may be purchased at almost all pro lighting stores). Your cables should be made with a male XLR connector at one end and a female XLR connector on the other. Also remember that DMX cable must be daisy chained and cannot be split.

**Special Note:** Line Termination. When longer runs of cable are used, you may need to use a terminator on the last unit to avoid erratic behavior. A terminator is a 110-120 ohm 1/4 watt resistor which is connected between pins 2 and 3 of a male XLR connector (DATA + and DATA -). This unit is inserted in the female XLR connector of the last unit in your daisy chain to terminate the line. Using a cable terminator (ADJ part number Z-DMX/T) will decrease the chances of erratic behavior.

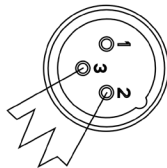
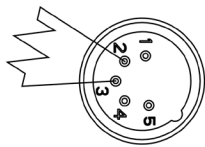

A DMX512 terminator reduces signal errors, avoiding most signal reflection interference. Connect PIN 2 (DMX-) and PIN 3 (DMX+) of the last fixture in series with a 120 Ohm, 1/4 W Resistor to terminate the DMX512.

# DMX SETUP

## DMX ADDRESSING

All fixtures should be given a DMX starting address when operating with a DMX controller, in order to ensure that the correct fixture responds to the correct control signal. This digital starting address is the channel number from which the fixture starts to “listen” to the digital control signal sent out from the DMX controller. The assignment of this starting DMX address is achieved by setting the correct DMX address on the digital control display on the fixture.

You can set the same starting address for all fixtures or a group of fixtures, or set different addresses for each individual fixture. Setting all fixtures to the same DMX address will cause all fixtures to react in the same way. In this case, please note that changing the settings of one channel will affect all the fixtures simultaneously.

If you set each fixture to a different DMX address, each unit will “listen” starting at the channel number you have set, based on the quantity of DMX channels of each fixture. That means changing the settings of one channel will only affect the selected fixture.

As an example, when operating this device in 6 channel mode, you should set the starting DMX address of the first unit to 1, the second unit to 7 (1 + 6), the third unit to 13 (1 + 6 + 6), and so on. (See the chart below for more details.)

| Channel Mode | Unit 1 Address | Unit 2 Address | Unit 3 Address | Unit 4 Address |
|--------------|----------------|----------------|----------------|----------------|
| 5 Channels   | 1              | 6              | 11             | 16             |
| 6 Channels   | 1              | 7              | 13             | 19             |
| 7 Channels   | 1              | 8              | 15             | 22             |
| 9 Channels   | 1              | 10             | 19             | 29             |
| 12 Channels  | 1              | 13             | 25             | 37             |
| 13 Channels  | 1              | 14             | 27             | 40             |
| 22 Channels  | 1              | 23             | 45             | 67             |
| 24 Channels  | 1              | 25             | 49             | 73             |
| 96 Channels  | 1              | 97             | 193            | 289            |
| 99 Channels  | 1              | 100            | 199            | 298            |
| 114 Channels | 1              | 115            | 229            | 343            |

# DMX TRAITS

| CHANNEL |      |      |      |       |       |       |       |       |       |         | DMX VALUES | FUNCTION                                    |
|---------|------|------|------|-------|-------|-------|-------|-------|-------|---------|------------|---|
| 5 CH    | 6 CH | 7 CH | 9 CH | 12 CH | 13 CH | 22 CH | 24 CH | 96 CH | 99 CH | 114 CH  |            |   |
|         | 1    | 1    | 1    | 1     |       | 1     | 1     |       |       |         | 0-255      | All Red, 0~100%                             |
|         | 2    | 2    | 2    | 2     |       | 2     | 2     |       |       |         | 0-255      | All Green, 0~100%                           |
|         | 3    | 3    | 3    | 3     |       | 3     | 3     |       |       |         | 0-255      | All Blue, 0~100%                            |
|         | 4    | 4    | 4    | 4     |       | 4     | 4     |       |       |         | 0-255      | All Amber, 0~100%                           |
|         | 5    | 5    | 5    | 5     |       | 5     | 5     |       |       |         | 0-255      | All Lime, 0~100%                            |
|         | 6    | 6    | 6    | 6     |       | 6     | 6     |       |       |         | 0-255      | All UV, 0~100%                              |
|         |      |      |      |       |       |       |       | 1     | 1     | 1       | 0-255      | Red1, 0~100%                                |
|         |      |      |      |       |       |       |       | 2     | 2     | 2       | 0-255      | Green 1, 0~100%                             |
|         |      |      |      |       |       |       |       | 3     | 3     | 3       | 0-255      | Blue 1, 0~100%                              |
|         |      |      |      |       |       |       |       | 4     | 4     | 4       | 0-255      | Amber 1, 0~100%                             |
|         |      |      |      |       |       |       |       | 5     | 5     | 5       | 0-255      | Lime 1, 0~100%                              |
|         |      |      |      |       |       |       |       | 6     | 6     | 6       | 0-255      | UV 1, 0~100%                                |
|         |      |      |      |       |       |       |       | ..    | ...   | ...     | 0-255      | ...   |
|         |      |      |      |       |       |       |       | 91    | 91    | 91      | 0-255      | Red 16, 0~100%                              |
|         |      |      |      |       |       |       |       | 92    | 92    | 92      | 0-255      | Green 16, 0~100%                            |
|         |      |      |      |       |       |       |       | 93    | 93    | 93      | 0-255      | Blue 16, 0~100%                             |
|         |      |      |      |       |       |       |       | 94    | 94    | 94      | 0-255      | Amber 16, 0~100%                            |
|         |      |      |      |       |       |       |       | 95    | 95    | 95      | 0-255      | Lime 16, 0~100%                             |
|         |      |      |      |       |       |       |       | 96    | 96    | 96      | 0-255      | UV 16, 0~100%                               |
|         |      |      |      |       | 1     | 7     | 7     |       |       | 97      | 0-255      | RGBAL+UV Color Macros                       |
|         |      |      | 7    | 7     |       | 8     | 8     |       | 97    | 98      | 0-255      | Background Red, 0~100%                      |
|         |      |      | 8    | 8     |       | 9     | 9     |       | 98    | 99      | 0-255      | Background Green, 0~100%                    |
|         |      |      | 9    | 9     |       | 10    | 10    |       | 99    | 100     | 0-255      | Background Blue, 0~100%                     |
|         |      |      |      |       | 2     | 11    | 11    |       |       | 101     | 0-255      | RGB Background Color Macros                 |
| 1       |      |      |      | 10    | 3     | 12    | 12    |       |       | 102     | 0-255      | Color Temperature 2300-9900K Linear, 0~100% |
| 2       |      |      |      |       | 4     | 13    | 13    |       |       | 103     |            | White Color Temperature Presets             |
|         |      |      |      |       |       |       |       |       |       | 0-22    |            | Open  |
|         |      |      |      |       |       |       |       |       |       | 23-99   |            | See WCT Preset Chart                        |
|         |      |      |      |       |       |       |       |       |       | 100-255 |            | No Function                                 |
| 3       |      |      |      |       |       |       |       |       |       | 104     |            | Shutter, Strobe                             |
|         |      |      |      |       |       |       |       |       |       | 0-31    |            | Led's Off                                   |
|         |      |      |      |       |       |       |       |       |       | 32-63   |            | Led's On                                    |
|         |      |      |      |       |       |       |       |       |       | 64-95   |            | Strobe effect slow to fast                  |
|         |      |      |      | 11    | 5     | 14    | 14    |       |       | 96-127  |            | Led's On                                    |
|         |      |      |      |       |       |       |       |       |       | 128-159 |            | Pulse-effect in sequences                   |
|         |      |      |      |       |       |       |       |       |       | 160-191 |            | Led's On                                    |
|         |      |      |      |       |       |       |       |       |       | 192-223 |            | Random strobe effect slow to fast           |
|         |      |      |      |       |       |       |       |       |       | 224-255 |            | Led's On                                    |
| 4       |      | 7    |      | 12    | 6     | 15    | 15    |       |       | 105     | 0-255      | Dimmer (Intensity), Intensity 0~100%        |
| 5       |      |      |      |       | 7     | 16    | 16    |       |       | 106     | 0-255      | Dimmer Fine (Intensity)                     |



# DMX TRAITS

| CHANNEL |      |      |      |       |       |       |       |       |       |        | DMX VALUES | FUNCTION                        |
|---------|------|------|------|-------|-------|-------|-------|-------|-------|--------|------------|---------------------------------|
| 5 CH    | 6 CH | 7 CH | 9 CH | 12 CH | 13 CH | 22 CH | 24 CH | 96 CH | 99 CH | 114 CH |            |                                 |
|         |      |      |      |       |       |       | 23    |       |       | 113    |            | <b>Dim Mode</b>                 |
|         |      |      |      |       |       |       |       |       |       |        |            | 000-020 Default to Unit Setting |
|         |      |      |      |       |       |       |       |       |       |        |            | 021-040 Standard                |
|         |      |      |      |       |       |       |       |       |       |        |            | 041-060 Stage                   |
|         |      |      |      |       |       |       |       |       |       |        |            | 061-080 TV                      |
|         |      |      |      |       |       |       |       |       |       |        |            | 081-100 Architectural           |
|         |      |      |      |       |       |       |       |       |       |        |            | 101-120 Theatre                 |
|         |      |      |      |       |       |       |       |       |       |        |            | 121-140 Stage 2                 |
|         |      |      |      |       |       |       |       |       |       |        |            | <b>Dim Speed</b>                |
|         |      |      |      |       |       |       |       |       |       |        | 141        | 0.1 s                           |
|         |      |      |      |       |       |       |       |       |       |        | 142        | 0.2 s                           |
|         |      |      |      |       |       |       |       |       |       |        | 143        | 0.3 s                           |
|         |      |      |      |       |       |       |       |       |       |        | 144        | 0.4 s                           |
|         |      |      |      |       |       |       |       |       |       |        | 145        | 0.5 s                           |
|         |      |      |      |       |       |       |       |       |       |        | 146        | 0.6 s                           |
|         |      |      |      |       |       |       |       |       |       |        | 147        | 0.7 s                           |
|         |      |      |      |       |       |       |       |       |       |        | 148        | 0.8 s                           |
|         |      |      |      |       |       |       |       |       |       |        | 149        | 0.9 s                           |
|         |      |      |      |       |       |       |       |       |       |        | 150        | 1 s                             |
|         |      |      |      |       |       |       |       |       |       |        | 151        | 1.5 s                           |
|         |      |      |      |       |       |       |       |       |       |        | 152        | 2 s                             |
|         |      |      |      |       |       |       |       |       |       |        | 153        | 3 s                             |
|         |      |      |      |       |       |       |       |       |       |        | 154        | 4 s                             |
|         |      |      |      |       |       |       |       |       |       |        | 155        | 5 s                             |
|         |      |      |      |       |       |       |       |       |       |        | 156        | 6 s                             |
|         |      |      |      |       |       |       |       |       |       |        | 157        | 7 s                             |
|         |      |      |      |       |       |       |       |       |       |        | 158        | 8 s                             |
|         |      |      |      |       |       |       |       |       |       |        | 159        | 9 s                             |
|         |      |      |      |       |       |       |       |       |       |        | 160        | 10 s                            |
|         |      |      |      |       |       |       |       |       |       |        |            | 161-255 Default to Unit Setting |
|         |      |      |      |       |       |       | 24    |       |       | 114    |            | <b>Dim Curves</b>               |
|         |      |      |      |       |       |       |       |       |       |        |            | 0-20 Square                     |
|         |      |      |      |       |       |       |       |       |       |        |            | 21-40 Linear                    |
|         |      |      |      |       |       |       |       |       |       |        |            | 41-60 Inv. Squa                 |
|         |      |      |      |       |       |       |       |       |       |        |            | 61-80 S. Curve                  |
|         |      |      |      |       |       |       |       |       |       |        |            | 81-255 No Function              |

# COLOR TEMPERATURE

| DMX VALUE | COLOR TEMPERATURE (K) | DMX VALUE | COLOR TEMPERATURE (K) |
|-----------|-----------------------|-----------|-----------------------|
| 23        | 2300                  | 63        | 6300                  |
| 24        | 2400                  | 64        | 6400                  |
| 25        | 2500                  | 65        | 6500                  |
| 26        | 2600                  | 66        | 6600                  |
| 27        | 2700                  | 67        | 6700                  |
| 28        | 2800                  | 68        | 6800                  |
| 29        | 2900                  | 69        | 6900                  |
| 30        | 3000                  | 70        | 7000                  |
| 31        | 3100                  | 71        | 7100                  |
| 32        | 3200                  | 72        | 7200                  |
| 33        | 3300                  | 73        | 7300                  |
| 34        | 3400                  | 74        | 7400                  |
| 35        | 3500                  | 75        | 7500                  |
| 36        | 3600                  | 76        | 7600                  |
| 37        | 3700                  | 77        | 7700                  |
| 38        | 3800                  | 78        | 7800                  |
| 39        | 3900                  | 79        | 7900                  |
| 40        | 4000                  | 80        | 8000                  |
| 41        | 4100                  | 81        | 8100                  |
| 42        | 4200                  | 82        | 8200                  |
| 43        | 4300                  | 83        | 8300                  |
| 44        | 4400                  | 84        | 8400                  |
| 45        | 4500                  | 85        | 8500                  |
| 46        | 4600                  | 86        | 8600                  |
| 47        | 4700                  | 87        | 8700                  |
| 48        | 4800                  | 88        | 8800                  |
| 49        | 4900                  | 89        | 8900                  |
| 50        | 5000                  | 90        | 9000                  |
| 51        | 5100                  | 91        | 9100                  |
| 52        | 5200                  | 92        | 9200                  |
| 53        | 5300                  | 93        | 9300                  |
| 54        | 5400                  | 94        | 9400                  |
| 55        | 5500                  | 95        | 9500                  |
| 56        | 5600                  | 96        | 9600                  |
| 57        | 5700                  | 97        | 9700                  |
| 58        | 5800                  | 98        | 9800                  |
| 59        | 5900                  | 99        | 9900                  |
| 60        | 6000                  |           |                       |
| 61        | 6100                  |           |                       |
| 62        | 6200                  |           |                       |

# COLOR MACROS CHART: RGBAL+UV

| Color          | DMX Value | RGBWAL+UV COLOR VALUES |     |      |     |      |     | Color          | DMX Value | RGB COLOR |       |      |
|----------------|-----------|------------------------|-----|------|-----|------|-----|----------------|-----------|-----------|-------|------|
|                |           | RED                    | GRN | BLUE | AMB | LIME | UV  |                |           | RED       | GREEN | BLUE |
| Off            | 0         | 0                      | 0   | 0    | 0   | 0    | 0   | Color Macro 33 | 129-132   | 255       | 206   | 143  |
| Color Macro 1  | 1-4       | 255                    | 0   | 0    | 0   | 0    | 0   | Color Macro 34 | 133-136   | 254       | 177   | 153  |
| Color Macro 2  | 5-8       | 0                      | 255 | 0    | 0   | 0    | 0   | Color Macro 35 | 137-140   | 254       | 192   | 138  |
| Color Macro 3  | 9-12      | 0                      | 0   | 255  | 0   | 0    | 0   | Color Macro 36 | 141-144   | 254       | 165   | 98   |
| Color Macro 4  | 13-16     | 0                      | 0   | 0    | 255 | 0    | 0   | Color Macro 37 | 145-148   | 254       | 121   | 0    |
| Color Macro 5  | 17-20     | 0                      | 0   | 0    | 0   | 255  | 0   | Color Macro 38 | 149-152   | 176       | 17    | 0    |
| Color Macro 6  | 21-24     | 0                      | 0   | 0    | 0   | 0    | 255 | Color Macro 39 | 153-156   | 96        | 0     | 11   |
| Color Macro 7  | 25-28     | 255                    | 255 | 255  | 255 | 255  | 255 | Color Macro 40 | 157-160   | 234       | 139   | 171  |
| Color Macro 8  | 29-32     | 255                    | 200 | 74   | 74  | 41   | 80  | Color Macro 41 | 161-164   | 224       | 5     | 97   |
| Color Macro 9  | 33-36     | 255                    | 166 | 77   | 77  | 2    | 26  | Color Macro 42 | 165-168   | 175       | 77    | 173  |
| Color Macro 10 | 37-40     | 255                    | 125 | 74   | 74  | 177  | 62  | Color Macro 43 | 169-172   | 119       | 130   | 199  |
| Color Macro 11 | 41-44     | 255                    | 97  | 77   | 74  | 65   | 33  | Color Macro 44 | 173-176   | 147       | 164   | 212  |
| Color Macro 12 | 45-48     | 255                    | 71  | 77   | 71  | 63   | 200 | Color Macro 45 | 177-180   | 88        | 2     | 163  |
| Color Macro 13 | 49-52     | 255                    | 83  | 134  | 83  | 21   | 176 | Color Macro 46 | 181-184   | 0         | 38    | 86   |
| Color Macro 14 | 53-56     | 255                    | 93  | 182  | 93  | 101  | 61  | Color Macro 47 | 185-188   | 0         | 142   | 208  |
| Color Macro 15 | 57-60     | 255                    | 96  | 236  | 96  | 38   | 44  | Color Macro 48 | 189-192   | 52        | 148   | 209  |
| Color Macro 16 | 61-64     | 238                    | 93  | 255  | 93  | 87   | 211 | Color Macro 49 | 193-196   | 1         | 134   | 201  |
| Color Macro 17 | 65-68     | 196                    | 87  | 255  | 87  | 0    | 255 | Color Macro 50 | 197-200   | 0         | 145   | 212  |
| Color Macro 18 | 69-72     | 150                    | 90  | 255  | 90  | 149  | 255 | Color Macro 51 | 201-204   | 0         | 121   | 192  |
| Color Macro 19 | 73-76     | 100                    | 77  | 255  | 77  | 11   | 125 | Color Macro 52 | 205-208   | 0         | 129   | 184  |
| Color Macro 20 | 77-80     | 77                     | 100 | 255  | 77  | 91   | 14  | Color Macro 53 | 209-212   | 0         | 83    | 115  |
| Color Macro 21 | 81-84     | 67                     | 148 | 255  | 67  | 38   | 189 | Color Macro 54 | 213-216   | 0         | 97    | 166  |
| Color Macro 22 | 85-88     | 77                     | 195 | 255  | 77  | 69   | 114 | Color Macro 55 | 217-220   | 1         | 100   | 167  |
| Color Macro 23 | 89-92     | 77                     | 195 | 255  | 77  | 46   | 210 | Color Macro 56 | 221-224   | 0         | 40    | 86   |
| Color Macro 24 | 93-96     | 158                    | 255 | 144  | 144 | 37   | 111 | Color Macro 57 | 225-228   | 209       | 219   | 182  |
| Color Macro 25 | 97-100    | 255                    | 251 | 153  | 153 | 121  | 11  | Color Macro 58 | 229-232   | 42        | 165   | 85   |
| Color Macro 26 | 101-104   | 255                    | 101 | 147  | 147 | 12   | 21  | Color Macro 59 | 233-236   | 0         | 46    | 35   |
| Color Macro 27 | 105-108   | 255                    | 138 | 186  | 138 | 9    | 140 | Color Macro 60 | 237-240   | 8         | 107   | 222  |
| Color Macro 28 | 109-112   | 255                    | 147 | 251  | 27  | 23   | 255 | Color Macro 61 | 241-244   | 80        | 255   | 234  |
| Color Macro 29 | 113-116   | 151                    | 138 | 255  | 138 | 50   | 196 | Color Macro 62 | 245-248   | 80        | 255   | 164  |
| Color Macro 30 | 117-120   | 99                     | 0   | 255  | 100 | 0    | 255 | Color Macro 63 | 249-252   | 77        | 255   | 112  |
| Color Macro 31 | 121-124   | 138                    | 169 | 255  | 138 | 19   | 212 | Color Macro 64 | 253-255   | 117       | 255   | 83   |
| Color Macro 32 | 128-128   | 255                    | 243 | 77   | 77  | 40   | 86  |                |           |           |       |      |

# COLOR MACROS CHART: BACKGROUND

| Color          | DMX Value | RGB COLOR INTENSITY |       |      | Color          | DMX Value | RGB COLOR INTENSITY |       |      |
|----------------|-----------|---------------------|-------|------|----------------|-----------|---------------------|-------|------|
|                |           | RED                 | GREEN | BLUE |                |           | RED                 | GREEN | BLUE |
| Off            | 0         | 0                   | 0     | 0    | Color Macro 33 | 129-132   | 255                 | 206   | 143  |
| Color Macro 1  | 1-4       | 80                  | 255   | 234  | Color Macro 34 | 133-136   | 254                 | 177   | 153  |
| Color Macro 2  | 5-8       | 80                  | 255   | 164  | Color Macro 35 | 137-140   | 254                 | 192   | 138  |
| Color Macro 3  | 9-12      | 77                  | 255   | 112  | Color Macro 36 | 141-144   | 254                 | 165   | 98   |
| Color Macro 4  | 13-16     | 117                 | 255   | 83   | Color Macro 37 | 145-148   | 254                 | 121   | 0    |
| Color Macro 5  | 17-20     | 160                 | 255   | 77   | Color Macro 38 | 149-152   | 176                 | 17    | 0    |
| Color Macro 6  | 21-24     | 223                 | 255   | 83   | Color Macro 39 | 153-156   | 96                  | 0     | 11   |
| Color Macro 7  | 25-28     | 255                 | 243   | 77   | Color Macro 40 | 157-160   | 234                 | 139   | 171  |
| Color Macro 8  | 29-32     | 255                 | 200   | 74   | Color Macro 41 | 161-164   | 224                 | 5     | 97   |
| Color Macro 9  | 33-36     | 255                 | 166   | 77   | Color Macro 42 | 165-168   | 175                 | 77    | 173  |
| Color Macro 10 | 37-40     | 255                 | 125   | 74   | Color Macro 43 | 169-172   | 119                 | 130   | 199  |
| Color Macro 11 | 41-44     | 255                 | 97    | 77   | Color Macro 44 | 173-176   | 147                 | 164   | 212  |
| Color Macro 12 | 45-48     | 255                 | 71    | 77   | Color Macro 45 | 177-180   | 88                  | 2     | 163  |
| Color Macro 13 | 49-52     | 255                 | 83    | 134  | Color Macro 46 | 181-184   | 0                   | 38    | 86   |
| Color Macro 14 | 53-56     | 255                 | 93    | 182  | Color Macro 47 | 185-188   | 0                   | 142   | 208  |
| Color Macro 15 | 57-60     | 255                 | 96    | 236  | Color Macro 48 | 189-192   | 52                  | 148   | 209  |
| Color Macro 16 | 61-64     | 238                 | 93    | 255  | Color Macro 49 | 193-196   | 1                   | 134   | 204  |
| Color Macro 17 | 65-68     | 196                 | 87    | 255  | Color Macro 50 | 197-200   | 0                   | 145   | 212  |
| Color Macro 18 | 69-72     | 150                 | 90    | 255  | Color Macro 51 | 201-204   | 0                   | 121   | 192  |
| Color Macro 19 | 73-76     | 100                 | 77    | 255  | Color Macro 52 | 205-208   | 0                   | 129   | 184  |
| Color Macro 20 | 77-80     | 77                  | 100   | 255  | Color Macro 53 | 209-212   | 0                   | 83    | 115  |
| Color Macro 21 | 81-84     | 67                  | 148   | 255  | Color Macro 54 | 213-216   | 0                   | 97    | 166  |
| Color Macro 22 | 85-88     | 77                  | 195   | 255  | Color Macro 55 | 217-220   | 1                   | 100   | 167  |
| Color Macro 23 | 89-92     | 77                  | 234   | 255  | Color Macro 56 | 221-224   | 0                   | 40    | 86   |
| Color Macro 24 | 93-96     | 158                 | 255   | 144  | Color Macro 57 | 225-228   | 209                 | 219   | 182  |
| Color Macro 25 | 97-100    | 255                 | 251   | 153  | Color Macro 58 | 229-232   | 42                  | 165   | 85   |
| Color Macro 26 | 101-104   | 255                 | 175   | 147  | Color Macro 59 | 233-236   | 0                   | 46    | 35   |
| Color Macro 27 | 105-108   | 255                 | 138   | 186  | Color Macro 60 | 237-240   | 8                   | 107   | 222  |
| Color Macro 28 | 109-112   | 255                 | 147   | 251  | Color Macro 61 | 241-244   | 255                 | 0     | 0    |
| Color Macro 29 | 113-116   | 151                 | 138   | 255  | Color Macro 62 | 245-248   | 0                   | 255   | 0    |
| Color Macro 30 | 117-120   | 99                  | 0     | 255  | Color Macro 63 | 249-252   | 0                   | 0     | 255  |
| Color Macro 31 | 121-124   | 138                 | 169   | 255  | Color Macro 64 | 253-255   | 255                 | 255   | 255  |
| Color Macro 32 | 128-128   | 61                  | 4     | 167  |                |           |                     |       |      |

# PIXEL FLIP

## PIXEL FLIP 1

|   |   |   |   |   |   |   |   |   |    |    |    |    |    |    |    |
|---|---|---|---|---|---|---|---|---|----|----|----|----|----|----|----|
| 1 | 2 | 3 | 4 | 5 | 6 | 7 | 8 | 9 | 10 | 11 | 12 | 13 | 14 | 15 | 16 |
|---|---|---|---|---|---|---|---|---|----|----|----|----|----|----|----|

## PIXEL FLIP 2

|    |    |    |    |    |    |    |   |   |   |   |   |   |   |   |   |
|----|----|----|----|----|----|----|---|---|---|---|---|---|---|---|---|
| 16 | 15 | 14 | 13 | 12 | 11 | 10 | 9 | 8 | 7 | 6 | 5 | 4 | 3 | 2 | 1 |
|----|----|----|----|----|----|----|---|---|---|---|---|---|---|---|---|

# REMOTE DEVICE MANAGEMENT (RDM)

**NOTE: for RDM to work properly, RDM enabled equipment must be used throughout the entire system, including DMX data splitters and wireless systems.**

Remote Device Management (RDM) is a protocol that sits on top of the DMX512 data standard for lighting, allowing the DMX systems of the fixtures to be modified and monitored remotely. This protocol is ideal for instances in which a unit is installed in a location that is not easily accessible.

With RDM, the DMX512 system becomes bi-directional, allowing a compatible RDM enabled controller to send out a signal to devices on the wire, as well as allowing the fixture to respond (known as a GET command). The controller can then use its SET command to modify settings that would typically have to be changed or viewed directly via the unit's display screen, including the DMX Address, DMX Channel Mode, and Temperature Sensors.

## FIXTURE RDM INFORMATION:

| RDM Code | Device ID | Device Model ID | Personality ID   |
|----------|-----------|-----------------|--|
| 1900     | 0000-FFFF | 2410            | 5CH, 6CH, 7CH, 9CH, 12CH, 13CH, 22CH, 24CH, 96CH, 99CH, 114CH, |

**Please be aware that not all RDM devices support all RDM features,** and therefore it is important to check beforehand to ensure that the equipment that you are considering includes all of the features that you require.

The following parameters are accessible in RDM on this device:

| Parameter ID           | Code    |
|------------------------|---------|
| DISC_UNIQUE_BRANCH     | 0x0001  |
| DISC_MUTE              | 0x0002  |
| DISC_UN_MUTE           | 0x0003  |
| SUPPORTED_PARAMATERS   | 0X0050  |
| DEVICE_INFO            | 0x0060  |
| MANUFACTURER_LABEL     | 0x0081  |
| DEVICE_LABEL           | 0x0082  |
| SOFTWARE_VERSION_LABEL | 0x00C0  |
| DMX_PERSONALITY        | 0x00E0  |
| DMX_START_ADDRESS      | 0x00F0  |
| SENSOR_VALUE           | 0x0201c |
| CURVE                  | 0x0343  |
| CURVE_DESCRIPTION      | 0x0344  |
| IDENTIFY_DEVICE        | 0X1000  |
| DMX_FAIL_MODE          | 0x0141  |

# CLEANING AND MAINTENANCE



**DISCONNECT POWER BEFORE PERFORMING ANY MAINTENANCE!**

## **CLEANING**

Frequent cleaning is recommended to ensure proper function, optimized light output, and an extended life. The frequency of cleaning depends on the environment in which the fixture operates: damp, smoky, or particularly dirty environments can cause greater accumulation of dirt on the fixture's optics. Clean the external lens surface periodically with a soft cloth to avoid dirt/debris accumulation.

**NEVER** use alcohol, solvents, or ammonia-based cleaners.

## **MAINTENANCE**

Regular inspections are recommended to ensure proper function and extended life. There are no user serviceable parts inside this fixture. Please refer all other service issues to an authorized ADJ service technician. Should you need any spare parts, please order genuine parts from your local ADJ dealer.

Please refer to the following points during routine inspections:

- A detailed electrical check by an approved electrical engineer every three months, to make sure the circuit contacts are in good condition and prevent overheating.
- Be sure all screws and fasteners are securely tightened at all times. Loose screws may fall out during normal operation, resulting in damage or injury as larger parts could fall.
- Check for any deformations on the housing, color lenses, rigging hardware, and rigging points (ceiling, suspension, trussing). Deformations in the housing could allow for dust or liquids to enter into the fixture. Damaged rigging points or unsecured rigging could cause fixture to fall and seriously injure a person(s).
- Electric power supply cables must not show any damage, material fatigue, or sediments.

**NEVER** remove the ground prong from the power cable.

# SPECIFICATIONS

## Features:

- 16 Pixel, Hex Color LED (RGBAL+UV) LED Bar
- Battery or Wall Powered
- Up to 20-Hours Battery Operation
- Battery Operation (Menu Option)
- Individual Pixel Control
- Built-In Foreground LED Programs
- Built-In Background LED Programs
- Variable White Color Temperature Control (2,300K ~ 9,900K)
- English & Spanish User Menu
- Built-In Alarm
- Color Calibrated LED's
- User Selectable LED Refresh Rates (900Hz ~ 25K)
- 6 User Selectable Dim Modes
- 4 User Selectable Dim Curves
- Electronic Strobe (0.3Hz ~ 11Hz)
- Electronic Dimming
- Attach up to two (2) ElectraPix Bar 16 to the Accu Stand VFB1 vertical floor base

## Source:

- (16) 20W Hex Color RGBAL+UV Foreground LEDs
- (66) 0.2W RGB Background LED's
- 50,000 Hour Average Life\*
- \*May vary depending on several factors including but not limited to: Environmental Conditions, Power/Voltage, Usage Patterns (On-Off Cycling), Control, and Dimming.

## Optical:

- 2,300K ~ 9,900K White Color Temperature Range
- 17° Beam Angle
- 45mm Lens Diameter x16

## Physical:

- IP65 Housing
- OLED Digital display
- L Track system for locking accessories / rigging
- Glare Shield
- Diffusion Filter slot
- Angle adjustable feet
- Horizontal slide lock to attach additional ElectraPix Bar 16 or ElectraPix Bar 8

## Control:

- DMX512
- Aria X2 Wireless Management / DMX system
- Bluetooth
- RDM and RDM Net Compatible
- IR (Includes UCIR24 wireless remote)
- (11) DMX Channel Modes (5, 6, 7, 9, 12, 13, 22, 24, 96, 99 & 114 Channel modes)
- On-board Manual Control Mode
- Primary / Secondary Mode

## Connections:

- 5pin XLR Outdoor DMX In/Out Sockets (Must be used with STRxxx, 5pin DMX cables to create IP65 seal)
- Outdoor Locking Power Sockets
- Battery Charging Socket

## Dimensions & Weight:

- Length: 45.4" (1154mm) Width: 6.5" (166mm) Height: 10.6" (269mm)
- Weight: 26.9 lbs. (12.2 kg)

## Power:

- AC100-240V/50Hz-60Hz Input
- 90W Power Consumption
- Link 10 pieces @120VAC or 18 pieces @ 230VAC

## Battery:

- Rechargeable Lithium ion
- Battery Capacity: 14,000mAh
- Battery Voltage: 22.2V
- Charge Time, AC Power: 5.5 Hours (To Full)
- Charge Time, Flight Case: 5.5 Hours (To Full)
- Up to 20-Hours Battery Operation
- Battery Cycles: 500

## Thermal:

- Ambient Operational Temperature: -4°F to 113°F (-20°C to 45°C)
- Storage Temperature: -22°F to 113°F (-30°C to 45°C)

## Certifications & IP Rating:

- CE, cETLus, FCC, IP65

## Included Accessories:

- (1) Outdoor Locking Power Cable
- (1) UCIR24 Remote
- (1) 20° Diffusion Filter

## Optional Accessories:

- Accu Stand VFB1 (Floor Base)
- LTrack A2 (LTrack Adapter Only)
- LTrack CA2 (LTrack Adapter with Narrow Clamp)
- EPIX B816 IPCB: replacement charging base and power supply



IP65

# DIMENSIONS

Dimensions are not drawn to scale.

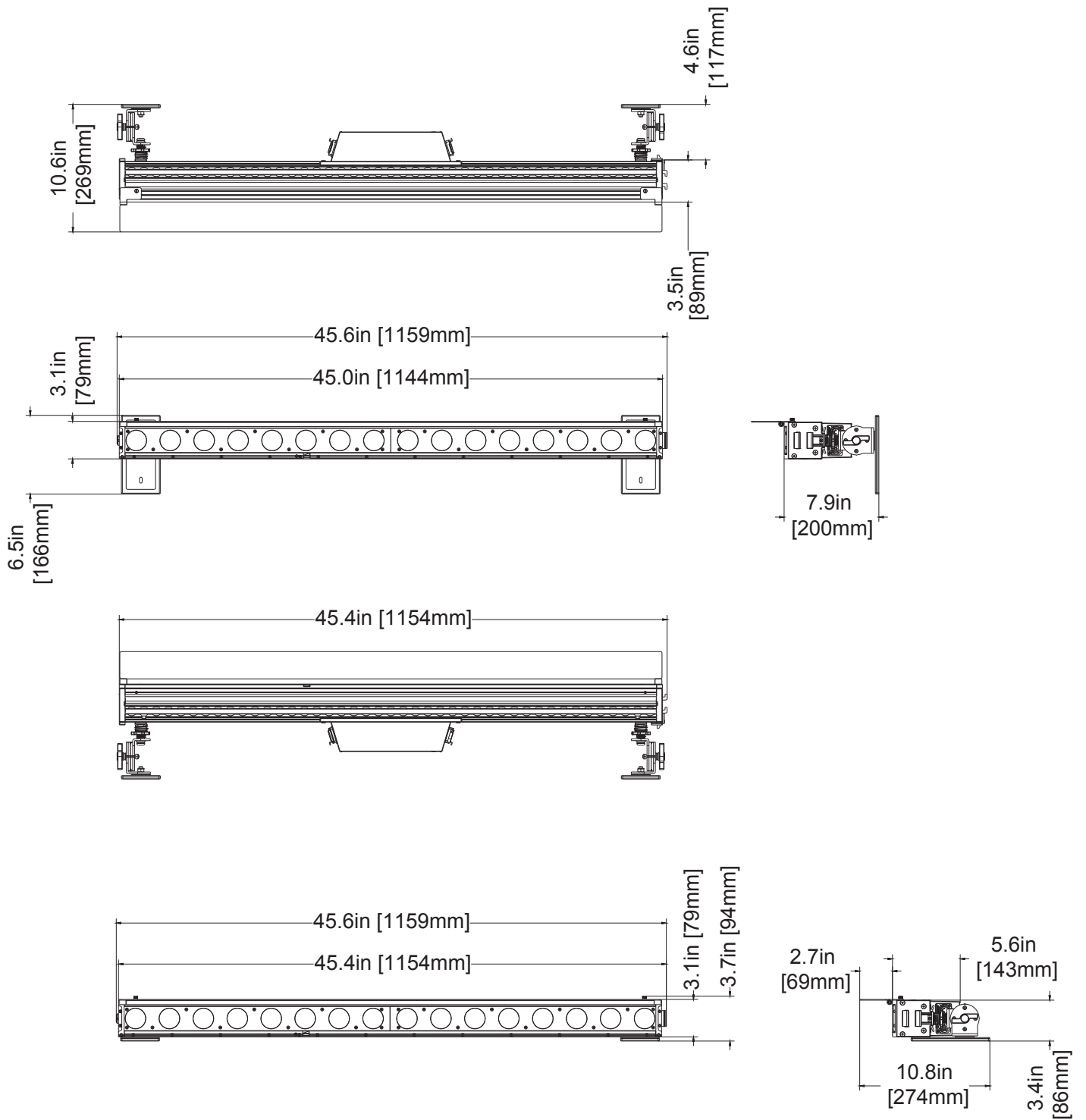

## OPTIONAL ACCESSORIES

| ORDER CODE    |              | ITEM   |
|---------------|--------------|--|
| US            | EU           |  |
| ELE160        | 1226100503   | ElectraPix Bar 16  |
| UC1024        | 810087371388 | UCIR24 Remote  |
| ACC111        | 810087372699 | Accu Stand VFB1 (Floor Base)                             |
| LTR008        | 810087372552 | LTrack A2 (LTrack Adapter Only)                          |
| LTR112        | 810087372576 | LTrack CA2 (LTrack Adapter with Narrow Clamp)            |
| PENDING       | PENDING      | EPIX B816 IPCB: replacement charging base & power supply |
| TRIGGER CLAMP | N/A          | Heavy Duty Wrap Around Hook Style Clamp                  |
| AC5PDMX5PRO   | N/A          | 5 ft. (1.5m) 5pin PRO DMX Cable                          |
|               |              | Additional Cable Lengths Available                       |



### FCC STATEMENT

Please note that changes or modifications to this product that have not been expressly approved by the party responsible for compliance could void the user's authority to operate the equipment.

NOTE: This equipment has been tested and found to comply with the limits for a Class A digital device, pursuant to part 15 of the FCC Rules. These limits are designed to provide reasonable protection against harmful interference when the equipment is operated in a commercial environment. This equipment generates, uses, and can radiate radio frequency energy and, if not installed and used in accordance with the instruction manual, may cause harmful interference to radio communications. Operation of this equipment in a residential area is likely to cause harmful interference, in which case the user will be required to correct the interference at his own expense.

### Energy Saving Matters (EuP 2009/125/EC)

Saving electric energy is a key to help protecting the environment. Please turn off all electrical products when they are not in use. To avoid power consumption in idle mode, disconnect all electrical equipment from power when not in use. Thank you!

